Masters Theses

Student Theses and Dissertations

Summer 2015

MR4RF: MEM-device with impedance and their usage with impedance matching networks for passive RFID tags in the UHF

George H. Harris

Follow this and additional works at: https://scholarsmine.mst.edu/masters_theses



Part of the [Electrical and Computer Engineering Commons](#)

Department:

Recommended Citation

Harris, George H., "MR4RF: MEM-device with impedance and their usage with impedance matching networks for passive RFID tags in the UHF" (2015). *Masters Theses*. 7853.
https://scholarsmine.mst.edu/masters_theses/7853

This thesis is brought to you by Scholars' Mine, a service of the Missouri S&T Library and Learning Resources. This work is protected by U. S. Copyright Law. Unauthorized use including reproduction for redistribution requires the permission of the copyright holder. For more information, please contact scholarsmine@mst.edu.

MR4RF: MEM-DEVICE WITH IMPEDANCE AND THEIR USAGE WITH
IMPEDANCE MATCHING NETWORKS FOR PASSIVE RFID TAGs IN THE UHF

by

GEORGE H. HARRIS

A THESIS

Presented to the Faculty of the Graduate School of the
MISSOURI UNIVERSITY OF SCIENCE AND TECHNOLOGY

In Partial Fulfillment of the Requirements for the Degree

MASTER OF SCIENCE IN COMPUTER ENGINEERING

2015

Approved by

Dr. Maciej Zawodniok
Dr. Jay Switzer
Dr. Jakub Koza

© 2015

George H. Harris

All Rights Reserved

ABSTRACT

The passive RFID tag in the UHF has been employed in several different applications including, tracking, logistics, and as a sensing platform for the Internet of things (IoT). The tag is ideal for this industry due to its unique design. It harvests all of its energy from the environment, and is small, cheap, and requires little to no maintenance. However, there are two major issues limiting the potential of the passive RFID systems: the limited power harvested by the tag, and the high susceptibility to interference and coupling. In particular, dynamic environments render the traditionally fixed, RF impedance matching network ineffective.

A novel design for a flexible Impedance-Switching Network (ISN) for passive RFID tags in the UHF is presented in this thesis. This novel approach can maximize power harvested by the tag. We propose two approaches to implementing the ISN. First, a more traditional design with a series of varactors is developed and studied. Each varactor is placed in parallel impedance lanes that are controlled via a feedback loop to maximize harvested power. A four-lane ISN is designed, tested, and tuned. The simulations and experiments demonstrate that ISN is capable of compensating for negative effect of mutual coupling in a ferromagnetic-reach environment.

The second design employs a new material called a memristive switch that can replace the varactors in the ISN. State of a memristive switch is non-volatile and requires little energy to operate, thus making it ideal for passive RFID tags. We are the first to characterize the Co_3O_4 based memristive switch in UHF range. The results show that it can be employed as a varying capacitor in the RF front-end design. We propose three general configurations for the ISNs.

ACKNOWLEDGMENTS

This material is based upon work supported by the National Science Foundation under Grant No. 0954031. Any opinions, findings, and conclusions or recommendations expressed in this material are those of the author(s) and do not necessarily reflect the views of the National Science Foundation.

TABLE OF CONTENTS

	Page
ABSTRACT	iii
ACKNOWLEDGMENTS	iv
LIST OF ILLUSTRATIONS	vii
LIST OF TABLES	viii
SECTION	
1. INTRODUCTION	1
2. IMPEDANCE SWITCHING NETWORK FOR RFID TAGS IN NON-IDEAL ENVIRONMENTS	8
2.1. INTRODUCTION	8
2.2. BACKGROUND	10
2.2.1. Impedance vs Power	11
2.2.2. RFIDs in Dynamic Environments	12
2.3. ISN DESIGN	15
2.4. RESULTS AND DISCUSSION	18
2.5. CONCLUSION	23
3. Au/Co ₃ O ₃ /Au BASED OXIDE MEMRISTIVE SWITCHES FOR DYNAMIC IMPEDANCE MATCHING IN PASSIVE RF FRONT-ENDS	24
3.1. INTRODUCTION	24
3.2. BACKGROUND	26
3.2.1. RFID Related Work.	27
3.2.2. Memristors, and Mem-Devices and their Future with RF Devices	29
3.2.3. Memristor Creation.	30
3.3. EXPERIMENTAL RESULTS FOR MEMRISTIVE SWITCHING IN RF BAND	32
3.3.1. Experiment Setup.	32

3.3.2. Experiment Procedure.	33
3.3.2.1 Lessons learned – 1-port calibration.	35
3.3.2.2 Lessons learned – port extension.	36
3.3.2.3 Lessons learned – electrostatic discharge.	36
3.3.2.4 Lessons learned – separating LRS and HRS measurements.	36
3.3.3. Results.	36
3.4. PROPOSED DESIGN OF THE MEMRISTIVE SWITCH-BASED IMPEDANCE NETWORK FOR RF.	39
3.5. CONCLUSION.	40
BIBLIOGRAPHY.	42
VITA.	48

LIST OF ILLUSTRATIONS

	Page
Figure 2.1. High level block diagram for Passive RFID Tag chips.....	8
Figure 2.2. Concept drawing of the ISN Network.....	9
Figure 2.3. Power vs Impedance graph.....	11
Figure 2.4. A typical RFID system graph depicting the RFID Tags' mutual interference state.	14
Figure 2.5. Low level model of the ISN Circuit.	15
Figure 2.6. Hardware test results	19
Figure 2.7. Simulation result of the ISN Gen 1 Lane Impedance vs. RFID Chip Power with coupling at min.	20
Figure 2.8. Simulation result of the ISN Gen 1 Lane Impedance vs. RFID Chip Power with coupling at max.....	20
Figure 2.9. ISN Gen 1 results.....	21
Figure 3.1. Proposed Impedance Matching Network for RFIDs with memristors that have impedance.....	25
Figure 3.2. Memristive switching process of the cobalt oxide	31
Figure 3.3. Experiment Setup.	33
Figure 3.4. Picture of the Pd tip Model 10 probe on top of the Co ₃ O ₄	34
Figure 3.5. Impedance measurements of the cobalt oxide memristive switch for frequencies up to 1.8GHz	38
Figure 3.6. High level model of the impedance matching network utilizing different mem-device characteristics.	39

LIST OF TABLES

	Page
Table 2.1 ISN GEN 1 Results Featuring Various Metals	22

1. INTRODUCTION

Passive Radio Frequency Identification (RFID) tags in the Ultra High Frequency (UHF) range are being introduced as the new low cost sensor for the internet of things (IoT). The industry of production and automation have started to adapt wireless sensors to monitor production lines, goods, and tools. Yet, passive RFID tags are not able to be placed in every environment. There are several issues with the passive RFID tags that need to be addressed before they can be used in such a manner.

The applications that passive RFID tags are used in range from smart tags [20], to sensing important vitals on humans [8]. This system is able to be implemented in such a vast array of applications, due to its simple nature. RFID systems are a master slave system in which the reader acts as the master and the tags are the slave. There are two types of RFID tags: passive and active. Active RFID tags rely on a power supply to communicate with the reader. The passive RFID tag harvests all of its power from the reader. Allowing it to be a low cost, small, and low maintenance sensor. However, this power scheme raises two distinct issues: a limited power supply for the tag chip, and the susceptibility to coupling and interference.

Passive RFID tags may only harvest a limited amount of power from the reader signal [24]. Due to the limited power, the tag must be built with as few components as possible. This leaves the tag with only the core components in order to function and perform its tasks. These components are a rectifier, de/modulator, memory control unit, and an internal clock. A fixed impedance matching unit is placed on the antenna to match the antenna impedance to the tag chip impedance. In past research, in order to reduce power draw the rectifier and the de/modulator received most of the focus [36-42]. This process can reach a plateau since it has physical limits.

Susceptibility to mutual coupling and interference is the second issue with passive RFID tags in the UHF. This is due to the limited reactance range of the impedance matching network on the tag. The impedance matching network typically resides on the antenna, matching to only a specific range of impedance [1-6]. Since the antenna is similar to an inductor, the tag becomes easily interfered with or coupled with neighboring objects and tags. When this happens several disadvantages present themselves:

communication range decreased, loss of power, and inability to work in dynamic environments.

Mutual coupling occurs when a passive RFID tag is near other tags or objects that produce a magnetic field. When a tag couples with others, its impedance can change causing incoming signals from the reader to be misread. Unmatched tags can also decrease the amount of power harvested by the tag. Too high or too low of an impedance can cause the tag to harvest to little amount of power. A matched impedance between the tag and the reader will always allow a passive RFID tag to harvest the maximum amount of power.

Passive RFID tags are also susceptible to interference from other tags. The backscattered signals that are sent out by neighboring tags cause interference amongst one another. The interference can also come from temperature, and a noisy background. Tags that have a large amount of interference can have their signal phase shifted when receiving and transmitting from and to the reader. Out of phase signals will cause mismatch between the tag and the reader, lowering harvested power. When a tag is considered to interfere with another, it is called a destructive tag. Passive RFID tags can also become constructive, aiding other tags and increasing communication range and harvested power.

Interference and coupling can greatly lower the amount of power harvested by the tag. Since the tag is already very limited in its power, any interference or coupling can severely cripple an entire RFID network. In order for passive RFID tags to remove the negative effects of coupling and interference a dynamic impedance matching network is required. In this thesis a novel design is simulated and tested. The Impedance Switching Network (ISN) is a new approach to solving the two major issues of passive RFID tags in the UHF: limited power delivered to the tag chip, and interference and coupling of the passive tag to objects and other tags. This unique design relies on impedance switches to control several impedance lanes to dynamically switch the passive RFID tag impedance. With the ability to dynamically switch a tag impedance, the passive ISN RFID tags will be capable of being used in dynamic environments. In this thesis, two different designs of the ISN are presented. The first is with conventional components, and the second with memristor devices.

The novelty of the ISN was postulated from the recent papers that demonstrated passive RFID tag exhibit a higher read rate with a matched impedance [23, 25]. Since the impedance between the tag antenna and chip are fixed, the tag itself is unable to remove any negative coupling effects. With the additional reactance, the tag can remove coupling and allow for communication with the reader. A dynamic impedance matching network will allow passive RFID tags in the UHF to branch into new applications. Tags will be able to be placed on goods and tools that need to be tracked in unique and dynamic environments. Most of all, it allows the passive RFID tag to be used in the Internet of Things (IoT).

The ISN design is very simple, utilizing several parallel impedance switches will allow the passive RFID tag to not only work in dynamic environments but harvest maximum energy at all times. Each lane has its own impedance range from the impedance switch and from the bias capacitors. The lanes are controlled by a closed feedback loop connected back to the memory control unit (MCU). The MCU decides which lanes are enable or disabled based on the power received by the tag chip. The feedback loop function is derived from the ISN impedance vs harvested power for the passive RFID tag chip. As the ISN impedance decreases, the harvested power increases, yet there is a maximum to this function. Once the maximum is reached, the harvested power will decrease. With an optimized harvested power vs impedance function, a feedback loop can be created to maximize harvested power for the tag chip by controlling the ISN impedance.

The first ISN was designed to work with ferromagnetic objects and was designed with varactors as the impedance switch. The ISN Gen 1 was the proof of concept to determine if it would be possible to cancel out coupling. Each lane was controlled with an open feedback loop using a power supply with manual input. A microcontroller system is in the design phase to start testing the feedback loop. In testing, the ISN Gen 1 was able to remove all ferromagnetic coupling. The first task of the board was to match the impedance of the ISN to the antenna. Once a near match was established, testing could begin with canceling coupling from ferromagnetic objects. The testing was performed in an anechoic chamber with the ISN placed on top of different metallic objects. The varactor switches were set to maximum, and several bias capacitors were used to nullify

all coupling. With ISN Gen 2, the ISN will be designed to balance out coupling and interference but to also maintain power requirements for passive RFID tags.

The ISN can be improved further with the usage of memristors as the impedance switch. Along with resistors, capacitors, and inductors, the memristor is a passive element and is considered the perfect switch. The memristor is a perfect switch because of its properties being non-volatile, multi-state, nano-device that can remember its mem-states. The memristor was first postulated by Dr. Chau in 1976 with the idea of a device that is able to switch between two states based on charge or electric flux. The memristor device had not been proven until in 2002, when HP designed the first one using a material stack up of Pt/TiO₂/Pt [28]. The metallic oxide metal sandwich allowed for a memristor to be created inside the oxide, while the metallic plates act as the electrodes for the device. The oxide has a large resistance, and requires to be broken down before a memristor can be formed. With HP proving the design of the memristor, a revolution in the electronics and physics world began, and new devices and applications were being created each year.

The memristor works by creating a change in voltage or current over the electrodes. At two distinct points of voltage or current, the memristor will either change from the Low Resistive State (LRS) or from the High Resistive State (HRS). The function of this I-V graph is a hysteresis loop that meets at the origin. The hysteresis loop is what defines the memristor as a switch. In the case of the Pt/TiO₂/Pt based memristor, the hysteresis loop spans both positive and negative voltage in order to switch between the LRS and HRS. Other materials may produce different types of hysteresis loops, especially those that create capacitance or inductance. These loops can be based off their respective system. In the case of memcapacitors their voltage-capacitance produces a hysteresis in the form of a circle [48].

The HP Pt/TiO₂/Pt based memristor was created by laying Pt nano-wires across each other with a thin film of TiO₂ placed on a whole surface, and the cell formed at intersections [28]. The crossbar structure allowed for a mux memristor network to be created, and postulated the first application with memristors: memory. As more research was conducted on the memristor, it was found that different materials caused different responses.

In [27], Chua and Di Ventra postulate the idea that memristors can become memcapacitors, or meminductors. These mem-devices are based off the same system as the memristor: both produce a hysteresis loop, and both have two or more mem-states. However, the plane in which these mem-devices work in are different from one-another. Memristors switch by changing current or voltage across the electrodes. Memcapacitors switch by changing charge or voltage across the electrodes. Meminductors switch by changing flux or current across the electrodes. Each mem-device also give a unique response when measured: Memristors – only resistance, Memcapacitors – resistance and capacitance, Meminductors – resistance and inductance. These additional mem-devices could help broaden the application of memristors, especially if a mem-device produces reactance.

The memristor has been presented in novel designs that range from memory units [52], to integration with FPGAs [53], and creating programmable interconnects [54]. With the introduction of the mem-devices, memristors and mem-devices could expand their application list to a larger audience. Mem-device that can produce capacitance have been postulated to work in chaotic [55] and neural networks [31, 56]. These types of mem-devices have only started to begun to be created [48], and further research needs to be conducted before these devices can be considered memcapacitors.

The idea of memristors that produce reactance can lead to applications that do not only exist in the DC world. In the paper [44], it was found that Au/ Mn₃O₄/Au based mem-devices could produce a capacitance reactance in the low frequency (LF) range. This postulated the idea that a mem-device that can exhibit impedance could be used in RF devices. In this thesis, a Au/Co₃O₄/Au based mem-device is demonstrated to produce a capacitance reactance in the UHF. This type of mem-device may be suitable for RFID applications. Yet there is a need for further research to understand the full nature of the Au/Co₃O₄/Au mem-device.

A memristor can become a mem-device with impedance based on the metallic filament that is created inside the Co₃O₄. The mem-device creates a capacitive like structure that exhibits its capacitance in the reset state. The as prepared mem-device has a high amount of resistance (M Ω) and must go through an “electro-forming” process to create the metallic filament. Once the metallic filament is created, the mem-device is

considered to be in the Low Resistive State (LRS) or set state. In the LRS, the mem-device is considered to be a short and has a very low resistance (Ω). In order to change states, the mem-device must be exposed to a change in current. It is theorized that as the current changes, the mem-device will oxidize a section of the metallic filament creating a gap of CoO_x between the filament and a Au electrode. This gap creates the capacitance nature, of the mem-device, and is now considered to be in the High Resistive State (HRS). Along with the capacitance produced, the HRS will have a high resistance ($\text{K}\Omega$) element as well.

The Au/ Co_3O_4 /Au mem-device should not be considered a memcapacitor. It is considered to be a memristor or a mem-device with impedance. The properties for a memcapacitor include that the device produce a capacitance in both the LRS and HRS. The Au/ Co_3O_4 /Au mem-device produces capacitance only in the HRS. The LRS is considered to be an inductor and resistor in parallel. Although the value of the inductor is unknown, its presence has been seen in both LF and UHF measurements.

In order to determine if the Au/ Co_3O_4 /Au mem-device was suitable for RF applications, the mem-device had to be characterized and an equivalent circuit was required. The Au/ Co_3O_4 /Au mem-device was measured with a VNA between 100MHz and 1.8GHz. The large range in frequency allowed for a full characterization of the mem-device. The HRS of the mem-device was measured with some difficulty, but it produced enough results to conclude several properties. The Au/ Co_3O_4 /Au mem-device in the HRS produced a semi-circle graph on a Nyquist Plot. This means that the HRS can be represented as a capacitor and resistor in parallel. The capacitance was measured between the femto-farad to pico-farad range, while the resistance was near $10\text{K}\Omega$ to $20\text{K}\Omega$. The LRS was unable to be measured with success that did not include a large amount of noise or parasitic components. It is believed that it could be considered an inductor and resistor in parallel. The resistance is easily measured in DC and is between 10Ω to 200Ω . The vast range is due to an unknown contact size that changes with each measurement. The inductance was undetermined and any results included added inductance most likely due to cable.

The Au/ Co_3O_4 /Au mem-device has been shown to produce a small amount of capacitance (fF – pF) in the HRS, which is ideal for UHF RF applications. In this thesis,

the Au/Co₃O₄/Au mem-device is considered to be an ideal candidate as an impedance switch for dynamic impedance matching networks for passive RFID tags in the UHF. Specifically, the mem-device is considered to replace the varactors in the ISN design presented earlier in this thesis. The mem-device will bring in a great number of benefits to the passive RFID tag.

Since the mem-device is a nano-device, non-volatile, impedance switch, it is ideal to be used in the ISN design. Although to be determined, the mem-device will require far less power to operate as a switch since, the requirements for switching states only requires a few micro-watts. The mem-device does not require any power to remember its state, and will do so always. The ability to remember its past state allows the ISN to become highly dynamic and lowers the overhead of the feedback loop. In all, the mem-device lowers power draw, and increases received harvested power by the tag chip.

With replacing varactors with Au/Co₃O₄/Au or other possibly more suitable oxide mem-devices, the ISN can become an enhanced version of itself. It would allow the passive RFID tag to include more sensors, and have a greater functionality. With the ISN dynamic impedance matching module, tags will be able to be placed in dynamically changing environments. The ISN will be capable of allowing RFIDs to be attached to objects in metallic containers, on components inside of a system, and create a low overhead network due to an internal feedback loop on the tag. These abilities can help create applications such as smart shelves [15, 19] and warehouses that are capable of self-inventory [51]. The greatest achievement the ISN can provide is the ability to bring all components, goods, and tools to the IoT for every industry. Tracking and maintenance of goods and inventory will have a lower cost, and a higher amount of detail and accuracy.

2. IMPEDANCE SWITCHING NETWORK FOR RFID TAGS IN NON-IDEAL ENVIRONMENTS

2.1. INTRODUCTION

Radio Frequency Identification (RFID) has been employed in several different technologies. They range from replacing barcodes with smart tags [20], used in mesh and motes networks [22], designed to keep track of inventory in smart shelves [15,19], to employing sensors on the human body [8]. Despite many benefits and advantages of RFID Technology there are many challenges preventing a wide spread usage. The main disadvantages are mutual coupling and interference caused by the environment and neighboring tags, and the low amount of power harvested by the tag.

RFID Technology is a master-slave system containing the RFID reader which is the master sending out all signals to the slaves. The slaves come in two types: Passive or Active RFID Tags. Most RFID tags are passive relying on the power from the RFID reader for both power up and communication. While Active RFID tags can get power from a battery, solar, or other power sources.

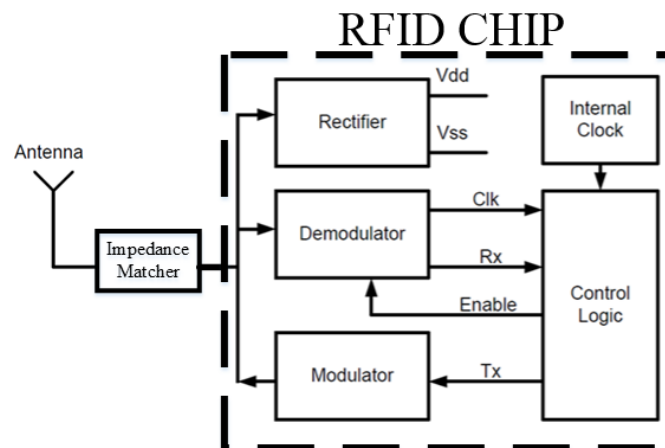

Figure 2.1. High level block diagram for Passive RFID Tag chips. The chip is designed with as few modules as possible to limit power draw. [24]

Passive RFID tags rely solely on the power they harvest from signals sent by the reader. RFID tags must utilize all the energy they harvest from the reader signal in order to power up, initiate, and transmit back a signal. This limits the amount of components and abilities the tag can have, and perform with each packet received. Passive tags use backscattering to communicate. They modulate the reflected signal to transmit data. A typical block diagram of an RFID Tag is shown in figure 1. The limited modules include a rectifier for power source, de/modulator for transmission, a fixed matching network, the actual logic chip and a clock to sync all the modules together.

Another major issue with RFID Tags is their susceptibility to interference and coupling [7,18,21]. The RFID antenna acts as a large inductor to harvest all the incoming signal power. The better the antenna, the greater the harvested energy. Presence of electromagnetic objects can affect the energy absorption due to coupling and interference. When a tag is placed in such an environment, it is common that the antenna is designed to offset coupling impedance. This works only in specific scenarios and is not flexible.

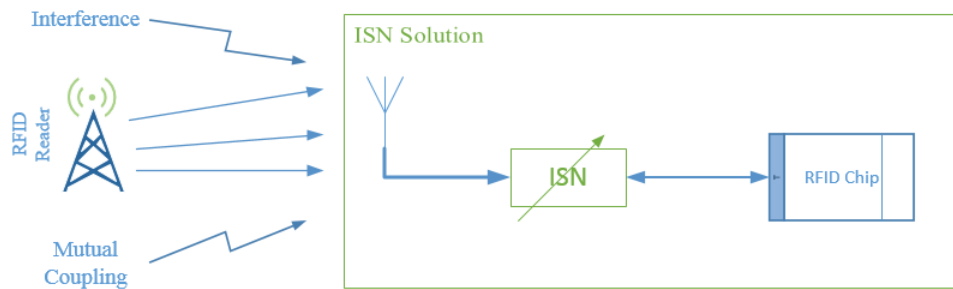

Figure 2.2. Concept drawing of the ISN Network. The Impedance Switching network is a variable Impedance Matching Network for RFID Tags, and is placed between the antenna and the RFID Tag Chip

A flexible/tunable impedance matching network is needed to address the two major issues: the limited power harvested and Interference. In order to help decrease power draw across the tag, it is common for the rectifier or the modulators to receive most of the attention in the design phase [26-32]. Increasing power efficiency in this manner has limits though. The rectifier and modulators have a maximum efficiency level. Power received by the tag chip also has a maximum but is dependent on the impedance matching network. Impedance matching networks are built into RFID tags, typically they reside in the antenna [1-6]. These types of impedance matching networks are only reliable in a configured environment where the tags are predictable in their behavior. In order for a flexible impedance network to work, it needs to constantly adjust its impedance to cancel out interference and coupling. This will thus increase power received by the tag chip.

In this paper, a novel approach to implementing an impedance matching module for RFIDs is proposed, modeled, and measured in an anechoic chamber. The Impedance Switching Network (ISN), figure 2, is a front end module for RFID tags to allow a high degree of flexibility. Utilizing multiple varactors, the RFID tag is able to choose a specific impedance range to match its surrounding. An open feedback loop is discussed and simulated to balance and find the optimal impedance for each RFID Tag within any environment.

2.2. BACKGROUND

Radio Frequency Identification (RFID) is a master slave system that allows for far field identification in the ultra-high frequency (UHF) range. The host being the RFID reader which sends information to the node (RFID tag) and receives the information stored. The RFID tag can be broken down into two variants: passive and active. Active tags have an attached power source that allows the tag to be more complex. Passive tags use a system called harvesting to harness all the power it needs. In this paper, we will exclusively discuss passive tags in the UHF.

Harvesting power means that the antenna of the RFID tag acts as a weak inductor to push power through the tag. This power system is what enables the tag to send back its information. The advantage to this power scheme allows the tag to be low cost, nearly

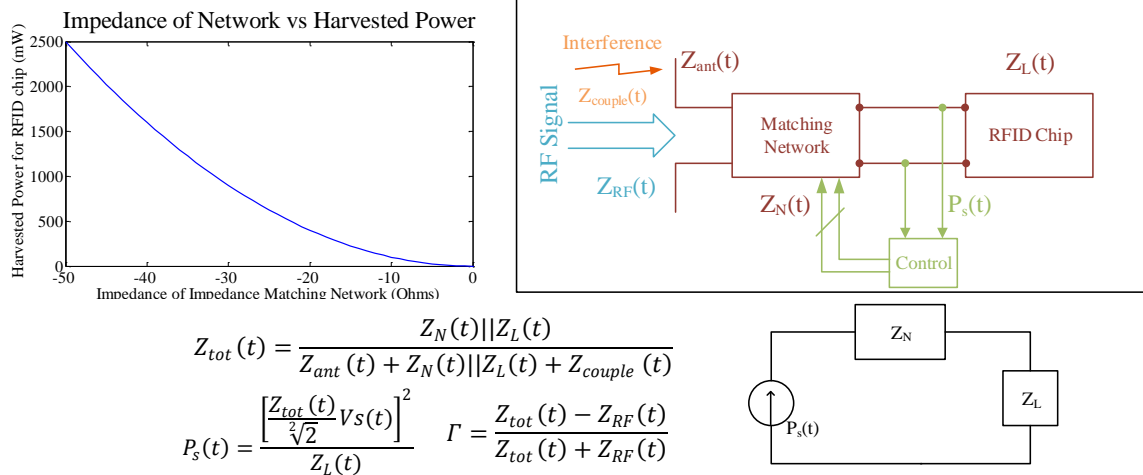

Figure 2.3. Power vs Impedance graph. As inbound impedance of RFID Reader's signal increases, the power of the RFID Chip receives also increases.

maintenance free, and require no battery power source. The disadvantage to harvesting power is the low amount of power received by the RFID tag chip (micro-watt to one watt maximum), high susceptibility to interference and coupling, and limited range of communication. These strong disadvantages are what can limit RFIDs in their advancement.

In order to allow RFIDs to work outside their configured environments, a study into the relationship of the power and interference has on the passive RFID tag in UHF is required. When a tag is placed into any environment, its impedance will change due to coupling or interference. This disadvantage lowers the amount of power harvested by the tag. The tag's relationship between impedance and power is first discussed and secondly the usage of these tags in dynamic environments.

2.2.1. Impedance vs Power. The amount of power harvested by a passive RFID tag in the UHF is directly dependent to the tag impedance [23]. The impedance of the tag is what allows for communication to occur. The passive RFID tag consists of several different parts that each have their own impedance. All of these parts must have a matched impedance along with the received signal impedance from the RFID reader. If there is a mismatch, the power of the impedance lowers. Yet, if the system is matched,

the power harvested can reach its maximum value.

The ISN will allow for a passive RFID tag in the UHF to include a tunable impedance matching network while also maintaining the power requirement for the chip. The power absorbed by the tag will follow a power vs impedance function, that when optimized will allow for all the needed power for an RFID tag. Figure 3, shows a graph of the power vs impedance function along with the impedances seen by the RFID tag. The feedback loop controlled matching network ($Z_N(t)$) will need to match to the impedance of the received RF signal ($Z_{RF}(t)$) and the RFID chip ($Z_L(t)$). The matched impedance relationship is represented by the function $\Gamma(t)$. As the function centers towards zero, the harvested power reaches its maximum. The harvested power function of the passive RFID tag can be seen in figure 3 as the $P_s(t)$ function.

Tunable impedance matching networks have never been implemented to passive RFID tags due to their large power draw and size. A tunable impedance matching network relies on a feedback loop in order to accurately assess its current impedance and calculate the required impedance to offset the environment influence. Due to the feedback loop, the RFID chip would need to waste energy while adjusting the impedance. Thus the benefits of the feedback loop need to outweigh the power loss.

Investigations into impedance matching have been performed before [1-6]. Most of these designs revolve around an impedance matcher on the antenna rather than on the RFID tag. Furthermore, in all of these instances, the antenna impedance is designed to match that of the tag for specific environment conditions. This simplifies the design of the RFID tag creating a unique tag for each environment. For example in [12], the investigators design an antenna for use with wire spools. The antenna is created with an offset impedance so that it can balance out the coupling effects when the tag is placed on top of the wire spool. This design process allows for the tag to work near the metal wire spool, but if placed anywhere else, the tag would have a mismatched impedance due to the antennas design constraints.

2.2.2. RFIDs in Dynamic Environments. For RFIDs, a dynamic environment is the amount of mutual interference [7,18], and mutual coupling [21], caused by neighboring tags, and ferromagnetic objects all in a time dependent environment. The

time variance is what really defines a dynamic environment. It represents the fact that the RFID tag must be able to change its impedance dynamically in order to operate in a dynamic environment.

From [25], it can be seen that the system can be improved with tags that can change their impedance dynamically. The goal of the research was to measure passive RFID tags in a freezer, but to do so multiple readers were required. Each tag offset impedance was able to be read due to a phase aligned reader. If the tags had a dynamically controlled impedance matcher, the number of antennas could be reduced. In a normal RFID environment, there is the reader and several tags in a close proximity. It does not matter if all or one of the tags is to be read when an attempt is made by the reader; each tag within the reader's range will be activated. The only tag(s) that will respond are those that have the corresponding ID(s) matched by the reader's request. As mentioned, all the tags within the environment will activate sending out some amount of reflected signals, causing mutual interference. Depending on several factors with each tag, (angle of alignment, range, impedance, and power) the tag's mutual interference can either be constructive or destructive to a neighboring tag. As figure 4 demonstrates, a constructive reflected signal will allow a neighboring tag to receive the reader's packet at a higher efficiency. This means that the tag could either communicate at a further distance, or receive more power, or other possibilities. Contrary, destructive reflected signals apply a negative effect toward neighboring tags. This could make tags that should be easily read unable to do so.

There is also another issue for RFID tags when randomly placing them in a dynamic environment, and that is the susceptibility to mutual coupling. For example, we can look at the case of placing a RFID tag onto a magnetic part. Since the tag's antenna is now attached to the magnetic part, this creates a strong inductive coupling that results in the antenna's impedance changing dramatically. The same can happen when a group of tags are close to each other. Demonstrated in [23], a tag's antenna will create an inductive coupling between other tags' antennas when neighboring one another. In this situation, the dynamics are increased dependent on movement and the amount of tags that may enter or leave the environment.

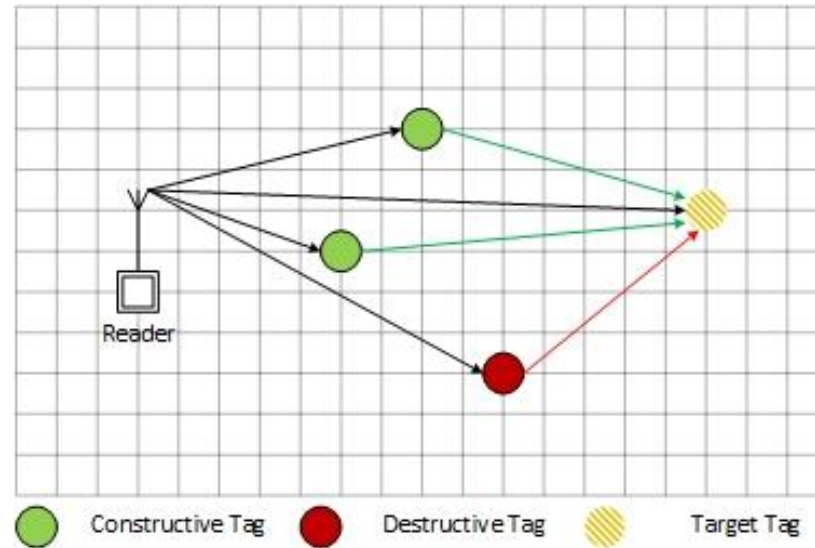

Figure 2.4. A typical RFID system graph depicting the RFID Tags' mutual interference state. In this figure, the RFID Reader is communicating with the Target RFID Tag in Orange. Neighboring tags either become Constructive (Green) or Destructive (Red) depending on several parameters. Constructive Tags are beneficial toward the Target Tag, while the Destructive Tags are non-beneficial.

Most of the impedance matching is based off of how the antenna was built. In several examples [8-14,16,17] other engineers have shown by designing an antenna for a specific placement on a specific metallic object, allows for the tag to be read. Yet, by this process, each tag would have to have its own antenna for every scenario; dramatically increasing cost, and lowering productivity. This process would limit the dynamics of the tag as a whole.

In a preliminary study [24], it was found that adding capacitance reactance between the antenna and the RFID chip helped cancel out the destructive signals of surrounding RFID tags. In this case, it's easily seen that strong inductive environment are cancelled by the capacitance allowing for a matched impedance scenario. In this scenario though, the researcher only sought to reduce the negativities of mutual coupling, and did not include a time varying scenario. Though, this postulates the idea that having varying selectable capacitors could allow an RFID Tag to adapt in an environment. RFID tags

with this ability will not only be able to communicate within a dynamic environment, but also allow for single targeting when many tags are present. This could also help reduce design costs for complicated antennas that have been discussed earlier.

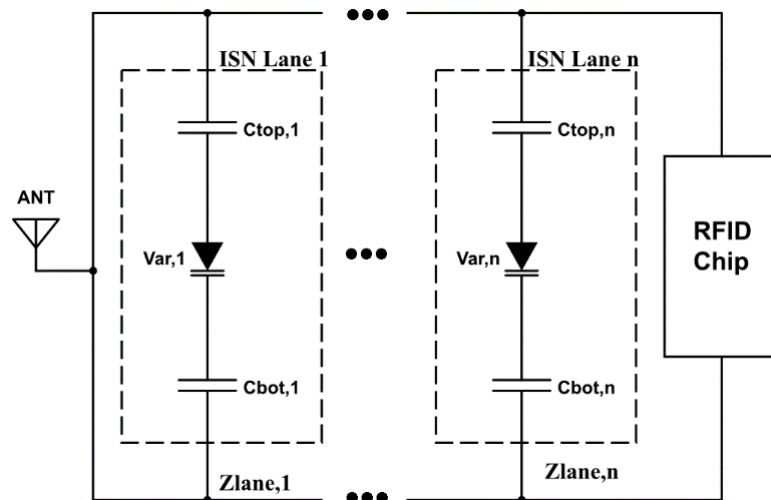

Figure 2.5. Low level model of the ISN Circuit. Each ISN Lane has two capacitors and a varactor. The capacitors act as bias impedances for each lane, while the varactors act as a variable impedance switch.

2.3. ISN DESIGN

The Impedance Switching Network (ISN) is a novel approach to designing a low power impedance matching module for passive RFID tags in the UHF. The ISN is composed of several impedance lanes called ISN Lanes. Each lane has a varying impedance that can dynamically change based on the voltage across the varactor. Each ISN Lane also has bias capacitors to create a constant capacitance. The concept design can be seen in figure 5. The ISN Module can have as many lanes as needed depending on how fine an impedance tuning is required.

Each ISN Lane's impedance is tuned with its varactor. The varactor acts like an impedance switch, closing and opening lanes as needed. To determine which lanes are to be selected, the RFID Tag will have each ISN Lane impedance range memorized. A closed loop and an optimized function based on the received Power for RFID Tag ($P_s(t)$) and the Impedance of the ISN ($Z_N(t)$) will regulate each Lane. The function $P_s(Z_N(t), V_s(t), Z_{couple}(t))$ is based off the ISN Impedance ($Z_N(t)$) the Input Voltage ($V_s(t)$), and the Impedance of the Coupling ($Z_{couple}(t)$), and in which all are time dependent.

$$P_s \left(Z_N(t), V_s(t), Z_{couple}(t) \right) = \frac{V_l^2 \left(Z_N(t), V_s(t), Z_{couple}(t) \right)}{Z_{RFID}} \quad (1)$$

Where $V_l(Z_N(t), V_s(t), Z_{couple}(t))$ is the Voltage across the RFID Chip:

$$V_l \left(Z_n(t), V_s(t), Z_{couple}(t) \right) = \frac{Z_N(V_r(t))}{Z_{couple}(t)} V_s(t) \quad (2)$$

Before the ISN can be implemented a study into the range of impedance for each ISN Lane is needed. Ideally this initial study would incorporate the effects of coupling, but for this paper, the impedance of each lane will be centered on the impedance of the RFID antenna. Once this starting point is established a simulation for the ISN board with coupling may begin. In both cases a simulation is needed to understand what bias capacitance and varactors are needed for the hardware design. Figure 6 shows a circuit diagram (6.i) and the varactor spice model (6.ii) for the simulation of the ISN board. Where, $Z_{ct}(V_r)$ is the impedance of the Varactor and $C_t(V_r)$ is the capacitance of the varactor.

In the hardware design, the Varactor is connected to the RFID Tag to create a closed loop voltage regulator. In the case of simulations, the voltage across the Varactor is controlled by a voltage source:

$$V_r = [V_{r,1} \dots V_{r,i}] \quad (3)$$

The voltage that is absorbed by the antenna is a complex voltage source:

$$V_s = V_{sp} e^{j\theta} \text{ where } V_{sp} = [V_{sp,1} \dots V_{sp,i}] \quad (4)$$

The impedance of the ISN Lane is the combination of the bias capacitor impedance, and the impedance of the varactor:

$$Z_{lane}(V_r) = Z_{ctop} + Z_{ct}(V_r) + Z_{cbot} \quad (5)$$

The impedance of the Coupling applied to the board is added with each lane. Since this circuit is modeled with a single lane, the impedance of the Coupling is therefore:

$$Z_{Couple} = j\omega L_{Couple} \text{ where } L_{couple} = [L_{c,1} \dots L_{c,i}] \quad (6)$$

In this model, the RFID Chip is simplified to a 50Ω resistor. To solve for the voltage across the RFID Chip, a voltage divider solution is utilized:

$$V_l = \frac{Z_{lane} || Z_l}{Z_{Ant} + Z_{lane} || Z_l + Z_{Couple}} V_s \quad (7)$$

Where V_l is the Voltage Load for the RFID Chip, R is the impedance of the RFID Chip, and Z_{ant} is the impedance of the Antenna. This solution is simplified to

$$V_l(V_r, V_s, Z_{Couple}) = \frac{Z_l * Z_{lane}(V_r)}{Z_{Ant}(Z_l + Z_{lane}(V_r)) + Z_l * Z_{lane} + Z_{Couple}(Z_l + Z_{lane}(V_r))} V_s \quad (8)$$

The RFID Chip is simplified to a real resistor so that the simulation can focus on finding the impedances that cancel out coupling impedances from the environment and the antenna. The ISN Lanes should almost always be matched to the RFID Chip. The power absorbed by the RFID Chip can then be calculated as a complex power solution given by

$$P_s(V_r, V_s, Z_{Couple}) = \frac{V_{RMS}^2}{Z_l}$$

$$\text{where } V_{RMS} = \frac{V_l(V_r, V_s, Z_{Couple})}{\sqrt{2}}$$

In this paper, an ISN Board was fabricated on an FR4 PCB substrate utilizing four ISN Lanes. Each ISN Lane was configured to have three Top and Bottom Bias capacitors. The numerous amount of capacitors would later be determined as unnecessary and ultimately affected all the results gathered, negatively. This issue is further discussed in section A of Results and Discussion.

2.4. RESULTS AND DISCUSSION

The ISN needs to go through several rounds of testing before it can be used with passive RFID tags in the UHF. First a hardware test to determine the effects of mutual coupling seen by metallic objects. This first test will define the range of capacitance for the ISN and each of its lanes. This first test was conducted with the ISN Gen 1 board. The Gen 2 board was soon simulated to understand the effects coupling had on the power harvested by the passive RFID tag. In both cases, the Gen 1 and Gen 2 board were created with several impedance lanes.

The Gen 1 board was the first attempt at designing an Impedance Switching Network. Gen 1's board design was robust and consisted of four ISN lanes and several bias capacitors for each lane. ISN Gen 1's goal was to determine the initial coupling and interference effects that would be applied during normal testing conditions. Along with this primary goal, the ISN Gen 1 was going to determine what capacitors would be needed for each lane. To do this, the board was created with as high configurability as possible. However this design feature turned out to be very detrimental to the research as a whole.

First off, the increased number of capacitors for each ISN Lane caused a high amount of parasitic and signal scattering inside the traces. The added parasitic capacitance due to the solder joints for each SMD capacitor would add enough that it

would skew the results. Signal scattering was caused by these soldering joints as well. With the additional capacitors, it was easy for the signal to have a high degree of phase change, thus causing the load impedance to switch from capacitive to inductive.

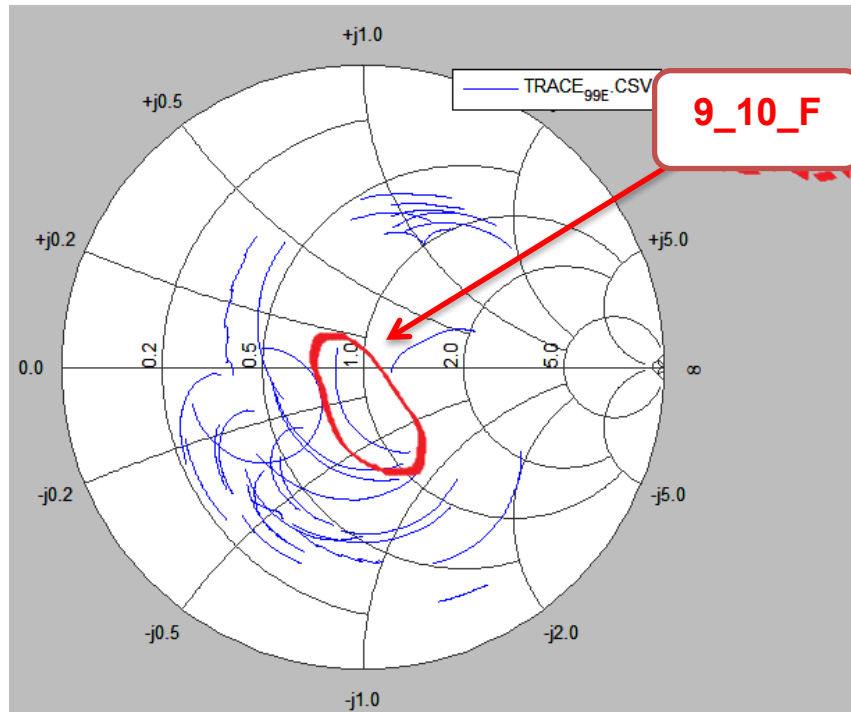

Figure 2.6. Hardware test results of cancelling out antenna impedance with bias capacitors on ISN Gen 1. The results are plotted on a real vs imaginary reflection smith chart.

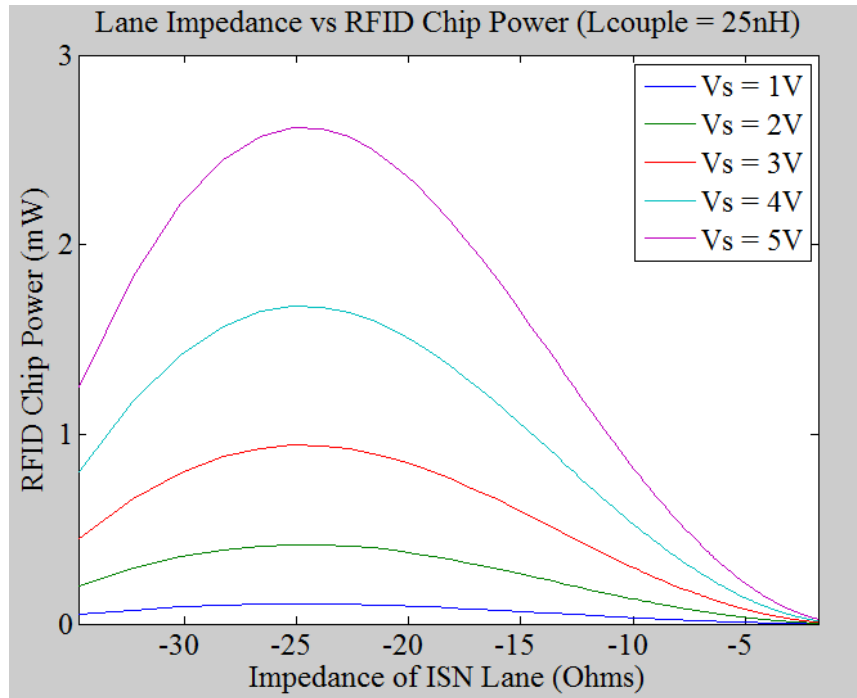

Figure 2.7. Simulation result of the ISN Gen 1 Lane Impedance vs. RFID Chip Power with coupling at min.

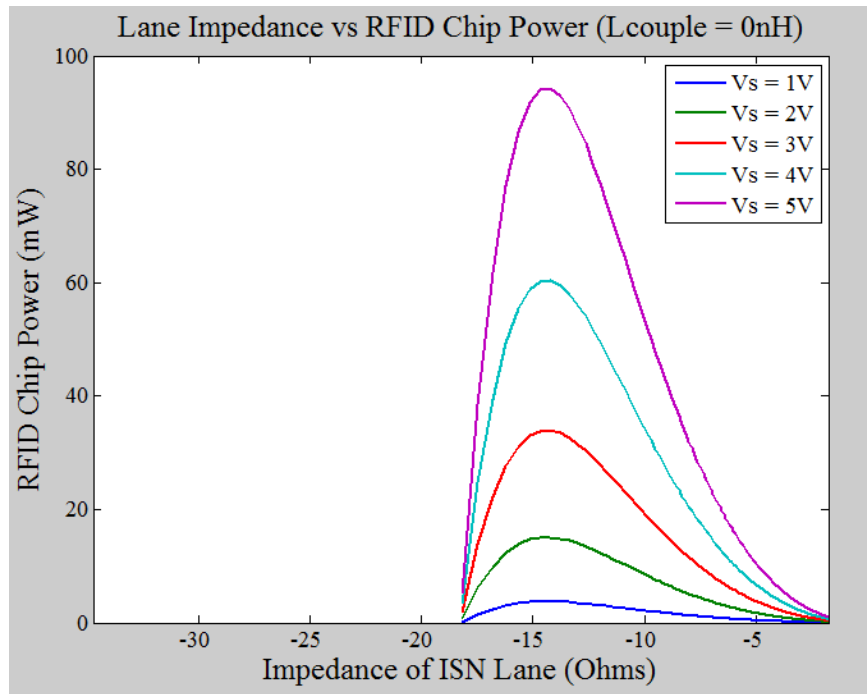

Figure 2.8. Simulation result of the ISN Gen 1 Lane Impedance vs. RFID Chip Power with coupling at max.

Secondly the Varactors would cause noise inside their lane if they were switching. Additional grounding was applied to the voltage connections to the varactors, but the noise still remained, however much weaker. This could be noise from the voltage source, or due to some design problem with the ISN Gen 1. Investigations into the matter is still underway.

Even though there were some flaws to the ISN Gen 1 boards, it was able to find capacitors that could meet our first goal: Remove the inductive coupling produced by the Antenna. Figure 7 shows the results of several different trials to remove the antennas impedance. The goal was to get the responding signal as near close to 1-to-1 match as possible. With these results, we were able to have three ISN Gen 1 boards usable for ferromagnetic testing.

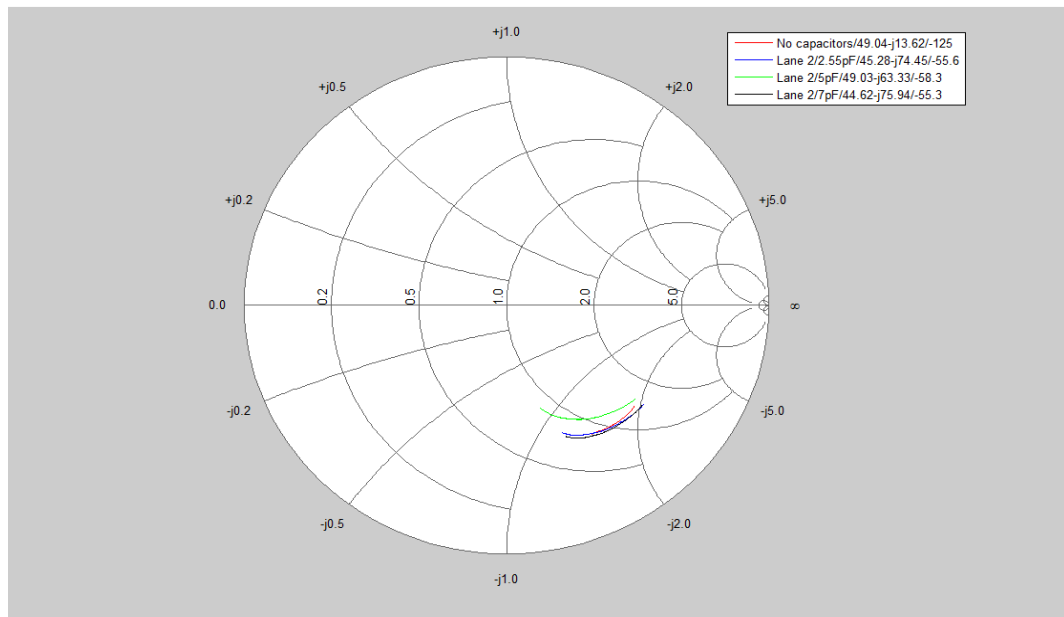

Figure 2.9. ISN Gen 1 results. The graph shows several different ISN Gen 1 boards and their impedance with no metal attached.

With the data on starting bias capacitors for each ISN Lane, the ISN's power could now be solved with the addition of coupling effects. Solutions (8) and (9) were used to solve for the power vs impedance functions. As stated in the ISN Design section, the simulation of the ISN only used one ISN Lane, and the total capacitance was the result of a single varactor (Z_N) and two bias capacitors (Z_{ctop} , Z_{cbot}). The coupling was chosen to be a high inductive coupling (Z_{couple}) effect that ranged from 0nH to 25nH. Figure 8 and 9 shows the results of the coupling effects in terms of ISN Impedance vs RFID Chip Power. Both results show that the load power will be in the low milli-watt range even when significant source voltage (V_s) is passed through the circuit. A higher presence of inductance will cause less power to be received by the RFID Chip.

Table 2.1 ISN GEN 1 Results Featuring Various Metals

	No Metal	Metal 1	Metal 2
Board 0	$0.225 + j14.722$	$0.233 + j14.676$	$0.202 + j14.895$
Board 1	$85.050 - j123.494$	$20.291 + j114.980$	$96.511 + j141.789$
Board 2	$50.649 - j105.642$	$70.45 + j124.638$	$40.215 - j105.62$
Board 3	$53.98 - j121.191$	$71.852 - j122$	$75.912 - j163.73$

Board 0 – ISN Board with no attached components.

Board 1 – ISN Board with all four lanes active with Varactors set to max.

Board 2 – ISN Board with lanes 2 and 4 active and Varactors set to max.

Board 3 – ISN Board with lanes 1 and 3 active and Varactors set to max.

Metal 1 – 12 mm thick steel slab

Metal 2 – 4 mm diameter aluminum rod.

In both cases, the ISN was also able to identify its impedance for maximum power received. As hypothesized, the ISN will be able to notice a change in power as the impedance switches between a high and a low state. These results will now be able to push the ISN into its next phase of testing: Active removal of negative coupling effects in a dynamic environment. In order to move onto this goal, first a study into how metallic

objects effect the ISN hardware. Secondly, the ISN needs test its switching capabilities with a Gen 2 board. Finally, a closed feedback loop needs to be developed to optimize the power of the RFID Chip based on the ISN Impedance.

Testing has started for determining the effects of coupling with the ISN Gen 1 Board. Better results will be attained with the revised ISN Gen 2 Board, yet early tests will be able to give initial insight in test setup, data acquisition, and coupling strength for each object that will be used in testing. Results of the coupling strengths can be seen in Figure 10 and Table I. Figure 10 shows each of the ISN Gen 1 boards that were able to be created from the very first round of tests. Each board is able to balance out the impedance of the Antenna. Table I shows how the boards reacted when near metallic objects. In most cases, the ISN Gen 1 board were not able to cancel out the coupling effects. Only one board was able to do so. The primary information gathered from these tests were the effects of the metallic objects onto these boards. This data has helped with the design of the Gen 2 boards.

2.5. CONCLUSION

In this paper, a dynamic impedance matching circuit for passive RFID tags in the UHF is presented. Its ability to cancel out negative coupling and interference produced by tags and objects allows the tag to harvest a higher amount of power. With this unique ability, the ISN can enable passive RFID tags to work in dynamic environments. Namely, those that require an impedance matching network to dynamically change its impedance due to a time variant environment.

The Impedance Switching Network allows for passive RFID tags to work in dynamic environments. It is seen in this paper removing the effects of coupling and allowing the maximum power harvested. Further research is needed to understand how the ISN interacts with other tags, and a feedback loop is needed to control each ISN Lane.

3. Au/C₀₃O₃/Au BASED OXIDE MEMRISTIVE SWITCHES FOR DYNAMIC IMPEDANCE MATCHING IN PASSIVE RF FRONT-ENDS

3.1. INTRODUCTION

The memristor is very well known in the physics and electronic world. Its introduction, by Dr. Chua [26], has led the way to the re-invention of modern electronics and computers. New types of memristors are being discovered every year, with proposals for all sorts of applications. For the first time, a memristor has been shown that not only has the standard resistance difference in states, but also impedance in the ultra-high frequency spectrum.

Memristors are classically classified by their hysteresis loop that pass through the origin, in the I-V graph. The hysteresis loop indicates that the memristor is capable of being in many different states, dependent on past charge (Q) or electric flux (ϕ). We denote these states as the High Resistive State (HRS) and the Low Resistive State (LRS). The difference between the two resistive states is typically three to nine orders of magnitude. With these standard properties always present, the memristor makes for an ideal candidate to replace all switches.

There are memristors that do not share all of the properties mentioned though. In recent years, other memristors have been found that do not produce a hysteresis loop that passes through the origin [43]. There are even some that do not create a twisted loop, but rather a complete single loop [50]. This means that we can classify memristors to be much more than just resistive switches. Different memristors offer different types of applications, than just the standard memory and transistor replacement.

Memristors with impedance could be used in passive RFID tags, replacing traditional limited impedance matching modules, with highly dynamic impedance matching. Typically impedance matching circuits for passive RFID tags reside on the antenna [5], but they can also be made with an analog varactor solution [29][30]. Memristors with impedance can also be applied in neural networks [31][32]. There are probably countless other applications that this memristor with impedance could be used in, just like the memristor. To plainly state, the benefits of working memristors can change the electronic world entirely.

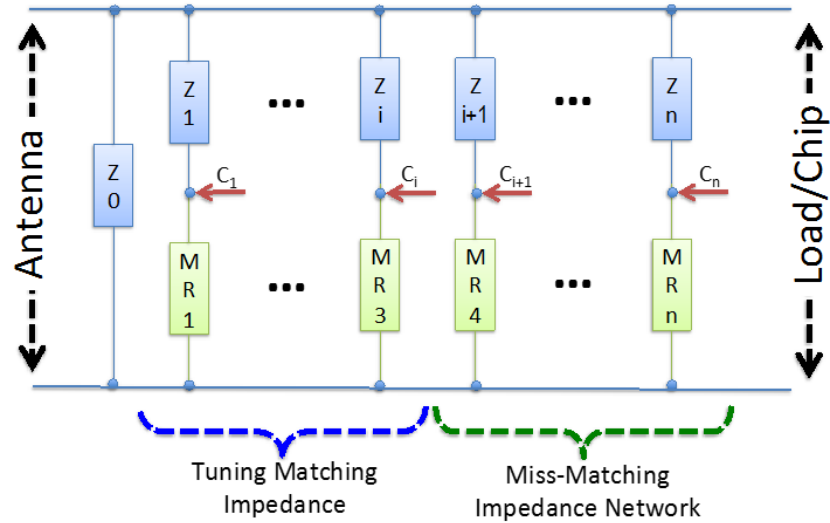

Figure 3.1. Proposed Impedance Matching Network for RFID lanes with memristors that have impedance. Z_i and Z_n denotes bias impedances for each lane. $M R_i$ denotes the memristor for each lane, and C_n is the control signal for lane.

In this paper, the benefits of the Au/Co₃O₄/Au based memristors and their application toward impedance matching networks are tested and discussed. These mem-devices create an ideal capacitance (femto-farad to pico-farad) that could be used for RFID applications. This pico-farad memristor may also help with many other high-frequency RF systems.

In an RFID environment, there is a RFID reader (host), and a RFID tag (node). The RFID tag relies on its antenna to harvest all of the tag's power when the Reader sends out a signal. This inductive coupling power technique provides only a maximum of 1 watt. Due to this limitation, the RFID tag is designed simply and with as few modules as possible. This also leads to other design flaws: susceptibility to interference and coupling.

With multiple RFID tags in an environment, each tag can become constructive or destructive due to their signal interference. If a RFID tag is destructive in an environment, it can cause the targeted tag to be unreadable or cause a bit error while the

targeted tag is being read. Oppositely, if a tag is constructive in an environment, it could allow the targeted tag to be read with higher precision or with little to no bit errors. With matching impedance values, the individual tags can become constructive, thus creating an environment to which each tag could be read without error.

Memristors with impedance or mem-devices are ideal for creating an RFID impedance balancing network. The Au/Co₃O₄/Au based mem-device can replace the varactors and create an offset impedance to balance the RFID tag's impedance. A high level model of the design concept is seen in figure 1. Each Impedance Lane is capable of switching between their own impedance range. A feedback circuit is needed to indicate which lanes are on or off. The circuit switches impedance by switching the mem-device. The mem-device's HRS acts as a capacitor with femto-farad to pico-farad capacitance. The LRS acts like a very weak Inductor allowing for the lane to become a short.

To begin an analysis on impedance switching with the Au/Co₃O₄/Au mem-device, we must first look at the behavior of the memristor in a high-frequency environment. So far, there has been little research done in this area. Second, we must look at how the memristors behave when applied in a parallel network. The second will be presented in an additional paper.

3.2. BACKGROUND

Applications with memristors have begun extensive research, since Hewlett Packard (HP) showed their memristor [28]. Most of these applications are towards replacing CMOS transistors with memristors. This is due to the fact that memristors are an ideal switch and can function as non-volatile memory. Furthermore, an added benefit to memristors is that they primarily exist in the nano-world. This gives great benefits to memory storage devices, such as resistive random access memory (RRAM).

The benefits of memristors, do not merely start and stop with the replacing of traditional transistors in a CMOS environment. The application of this new technology can be brought into traditional circuits, mainly those used in low power circuits. Memristors can be created with many sorts of different materials such as titanium, cobalt, silicon, and more, with each combination creating a unique set of characteristics. Titanium oxide (TiO₂) memristors create a resistive difference between HRS and LRS

that can be used for DC switching [46]. Hausmannite (Mn_3O_4) has a distinctly large resistive difference that it can be used for memory application [43]. Hausmannite based memristors also exhibit impedance when they are measured at a Low Frequency (LF) [44], which can be used for RF applications. Memristors can be created in many different ways and each can allow the memristor to be applied in unique applications.

3.2.1. RFID Related Work. The effects of impedance of RF devices on the reflected signal apply to any type of RF systems. However, due to the operating conditions and physical limitations of the application, a passive RFID tag can benefit the most by employing the memristor in an impedance matching networks. Another potential application includes an adaptive hybrid antenna where an array of passive elements around the active one increases the gain and directionality of such hybrid antenna setup.

In recent years, a passive scattering based wireless communication is becoming an attractive alternative to the traditional, active transmission systems. The main benefits are a low power, inexpensive, and often battery-less design since the device requires less power to operate and can be implemented as a system-on-a-chip (SOC). The most commercialized application of the backscatter-based communication is the Radio Frequency Identification (RFID) system. The passive RFID tags communicate a unique identification to an active reader, which generates the incident signal for energy harvesting and backscattering. Furthermore, such systems are increasingly employed in sensing applications [33-35]. The low power, small form factor wireless sensors have potential of making the concept of a “smart dust” a reality. However, due to path loss and signal fading on wireless links, the communication range of passive systems is limited to no more than couple tens of feet. Furthermore, such passive devices often harvest energy from the original RF signal transmitted by the reader/base station. There is a minimal amount of RF power required to wake and power such a passive device up. Consequently, in presence of fading channel, for example due to shadowing and multipath propagation, a passive device is often unable to receive sufficient energy to operate and successfully communicate. This limits the usage of backscatter-based communication to short-range wireless applications.

Passive RFID tag uses the received reader's signal both (a) to harvest energy thus powering up its circuitry and (b) to communicate back by modulating the scattered signal through chip impedance switching. Designing an effective passive tag is a challenging task. Traditionally, a lot of emphasis has been given to designing rectifier, regulator, and backscattering circuitry [36-42]. Rectifier harvests the incident RF signal to provide power for the entire tag. Regulator maintains the power supply voltage to a certain minimum level. The backscattering circuitry supports communication with the reader. Design of an efficient rectifier and regulator ensures sufficient power is transferred from the incident RF signal to the digital circuitry such that the tag can correctly operate. It is desired to power up the tags even in a presence of a weak incident RF signal at a larger distance from the reader. On the other hand, the backscattering circuitry aims at maximizing the power of the reflected signal to ensure reliable communication toward the reader. These opposing goals of both transferring the most energy to power circuitry and reflecting the most energy for communication are satisfied by switching the impedance matching network connected to the tag's antenna.

The typical RFID tags employ semiconductor technology (e.g. FET transistors and diodes) [36-42] to accomplish those tasks. This creates nonlinear behavior of the energy harvesting and backscattering circuits. In particular, for a weak RF signal, the voltage generated at the antenna might be insufficient to "activate" the entire desired impedance matching network. The branches with semiconductor will become disconnected if the voltage generated by incident signal is below their bias voltage. Consequently, in such scenario, the effective impedance of the impedance matching network will only include the paths with the linear components including resistors, capacitors, and inductors. In traditional approaches such effective impedance matching network becomes a fixed, uncontrolled quantity in the presence of weak signals. In contrast, the proposed employment of a memristor would enable dynamic switching of impedance since memristor behaves as a passive component at low signal levels. Consequently, the tag can scatter the weak signal more efficiently thus potentially extending the effective range of communication. Moreover, as discussed in details in subsequent sections, the memristors do not require a constant, state-holding supply power and potentially can use less energy for switching than semiconductors.

Next, we discuss the two important aspects of the passive RF front-end's (antenna and impedance-matching network) interaction with incident RF signal. The scattering describes the reflection of RF signal from a relatively small object and varies with its impedance. This is a typical scenario in the far-field range. In contrast, mutual coupling describes the mutual interactions among closely located devices. Their internal impedances change due to proximity of other scatterers.

3.2.2. Memristors, and Mem-Devices and their Future with RF Devices.

Memristors are well known these days as the new memory device. They are also the forerunners in the race for the replacement of the silicon transistor. As Intel, Samsung, and the other big fabs continue their work on shrinking the transistor, universities and research groups are making leeway on the understanding of the nature of the memristor. There have been several discoveries surrounding the memristor, and each new arrangement of materials creates a unique set of properties for each one.

A memristor is considered the perfect switch due to its native properties of being non-volatile, multi-state, nano-device, which can remember its states. It retains its state, High for Off and Low for On, even when power is removed. The states each act a like a resistive switch: The High Resistive State (HRS) has a resistance between kilo-ohm to giga-ohm. While the Low Resistive State (LRS) has a much smaller resistance, usually less than 100ohms. In order to switch a memristor between the HRS and LRS, it must accept a different charge or electric flux.

The material formula to create a memristor is simple to understand: a metal sandwich with a metal oxide in the center. The memristor's properties greatly depend on its metal oxide. For example, titanium oxide ($K\Omega$ to 100Ω) has a lower HRS to LRS ratio than Hausmannite ($M\Omega$ to 25Ω). There are forms of silicon oxide memristors that are being used to create memristors with current fab equipment. There are metal oxides that change memristors to act outside of their normal behaviors.

Different materials can create different types of memristors. Memristors can become capacitive or inductive, creating memcapacitors and meminductors. These type of mem-devices were first presented in [27], where Di Ventra and Chua defined the mem-devices. Memristors work by changing voltage or current producing a hysteresis loop on

an I-V graph. Memcapacitors create a hysteresis loop that is not pinched on a Q-V graph. Meminductors are theorized to produce an identical hysteresis loop to the memcapacitor but on an ϕ -I graph.

The key definition for these mem-devices are the equivalent circuits they create. Memristors produce solely resistance in both the HRS and LRS. Memcapacitors will produce capacitance in both states, and the same with meminductors but with inductance. It is then likely that both memcapacitors and meminductors will produce a reactance in an AC environment, however these type of mem-devices have not yet been seen. There have been some mem-devices that produce capacitance and act like a memcapacitor [46,48,49], but their abilities have not been measured in the UHF band.

The Au/Co₃O₄/Au mem-device is not a memcapacitor, it is a memristive impedance switch. It behaves like a memristor, and is able to switch between HRS and LRS, but it does not produce capacitance reactance in both HRS and LRS. The Au/Co₃O₄/Au memristor or mem-device that is studied in this paper is a mem-device with impedance. The impedance can be seen in the LF to UHF. When a DC signal is applied, the cobalt oxide memristor presents a resistance between the mega ohms to low ohms.

Due to the unique property of the Au/Co₃O₄/Au mem-device, it can be used in applications outside of memory. Memristors could be employed in RF circuitry to reduce power draw and induced switching noise. The cobalt oxide mem-device produces a small amount of capacitance (pF) which is ideal for UHF RF applications. One such application is RFIDs, specifically power optimization for Passive RFID Tags.

3.2.3. Memristor Creation. A memristor is created by first creating the device, then stabilizing it. Figure 2 shows the steps and I-V graph for creating, and setting a memristor. When the memristor is first created, the metal oxide is in an as-deposited state. This means that no AC at HF electric pulse can go through the material, and the device is seen as a high resistive material (usually in the high M Ω to low G Ω). In order to create a memristor the material needs to be broken down. In the case of the Au/Co₃O₄/Au mem-device it requires ~15V and ~10mA to break the material down and create the metallic filament in the material.

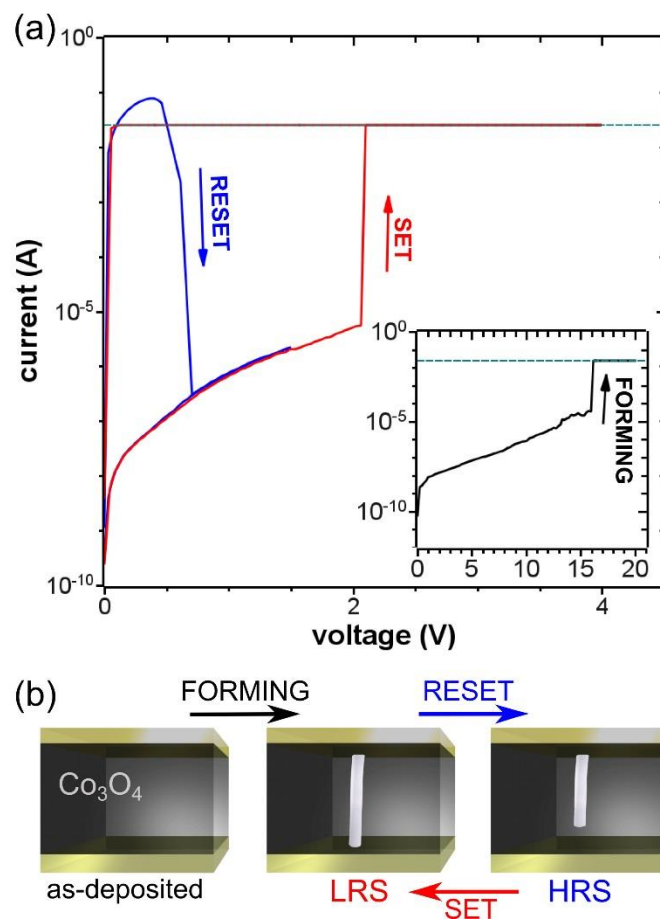

Figure 3.2. Memristive switching process of the cobalt oxide: (a) IV curves for formation, set, and reset transitions of the memristive switch; (b) graphical representation of the states and the transitions

When the metallic filament is formed, the mem-device is now considered to be in the LRS. This means the metallic filament has a complete connection between the top and bottom metals creating a short. This short wire has very low inductance (near low nH) with a small amount of resistance in parallel. The mem-device now needs to be stabilized in order for it to maintain the metallic filament.

In order to change the mem-device from the LRS to HRS, a small amount of charge is required. Typically the mem-device will switch around 1V at $\sim 20\text{mA}$. Once this happens, the mem-device will switch the HRS and some of the filament will remain

behind. Due to this gap, and the natural resistance of the cobalt oxide, a capacitance is created and has an impedance response. The size of the gap is unknown, but its diameter can be influenced. With proper control of the materials and test setup, better mem-devices can be created.

The mem-device still needs to be switched several times before the filament can be considered stabilized. Once this fitting procedure is complete, the mem-device is ready for measurements.

3.3. EXPERIMENTAL RESULTS FOR MEMRISTIVE SWITCHING IN RF BAND

3.3.1. Experiment Setup. The memristors were measured with a Vector Network Analyzer (VNA) connected to a micro-probe. The micro-probe station was a standard microscope plus mechanically controlled probe setup, with the probe's tips providing complete connection to the memristor. Each probe and probe arm are a Model 10 Palladium tipped probe made by GGB. The tips were 125 μm in diameter in a two tip configuration: ground and signal. The probe arm has a single SMA cable, which was connected to an Agilent B2911A Series Source Measurement Unit (SMU) and a Agilent E5601B VNA. Figure 6 shows a picture and a depiction of the experiment setup.

The VNA is setup to measure channel between 1 MHz to 1.8 GHz. The VNA is calibrated with a 1-port calibration plus port extension. The calibration kit is a GGB standard 1-port calibration kit designed for the Model 10 probe line.

It should be noted that the memristor under test is a Pd/Co₃O₄/Au memristor. The memristor produced and characterized earlier was an Au/Co₃O₄/Au. The difference in the probe tips did not have an observable impact.

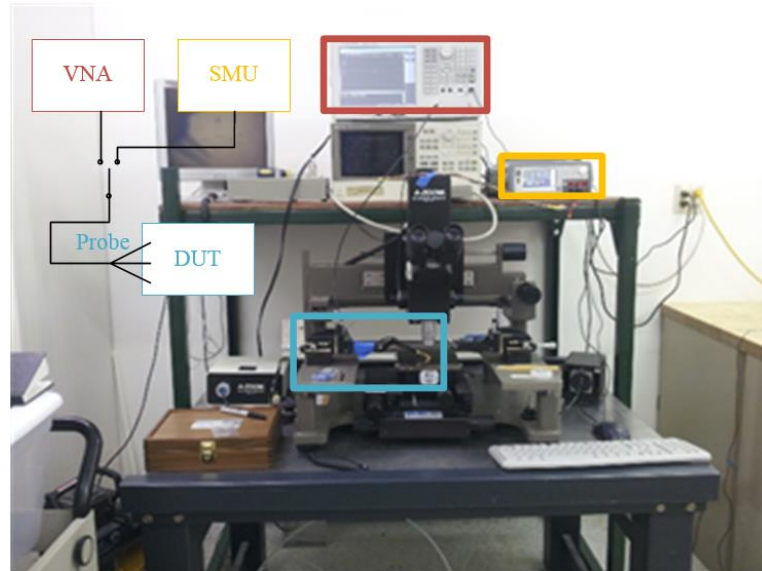

Figure 3.3. Experiment Setup. Red: Agilent VNA, Orange: Agilent Source Measurement Unit (SMU), and Blue: Microprobe arm and memristor under test.

3.3.2. Experiment Procedure. There are several steps before the mem-device can be measured by the VNA. First the VNA needs to be calibrated which must utilize a custom calibration kit. Second, the mem-device needs to be created, and then conditioned. After the mem-device is conditioned, measurements may begin.

In order for the VNA to measure any device under test (DUT), it needs to be calibrated. This step allows the VNA to remove any extra components (i.e. cables, and probe) that may cause results to become skewed. The calibration requires one port, and three standards: open, short, load. The open standard acts like a capacitance, while the short standard acts like an inductor. The load standard is a 50Ω resistor.

In most cases, the VNA requires a calibration kit that was manufactured with high precision for a specific frequency range. In the case of mem-devices, the VNA requires a new calibration kit. The standard open and standard short created values that were much larger than those measured from the memristor. In order to allow for finer tuning with the VNA, a new open and short was created with lower values.

Once the VNA is calibrated, the SMU is used to form the mem-device. This step was dependent on the thickness of the micro-probe. With a new micro-probe, mem-devices are easier to create, but as the micro-probe is used throughout a session, it becomes harder to create a mem-device. This was due to the Palladium thickness for each micro-probe. With each creation, the thickness would decrease due to oxidation, to the point where the micro-probe was useless.

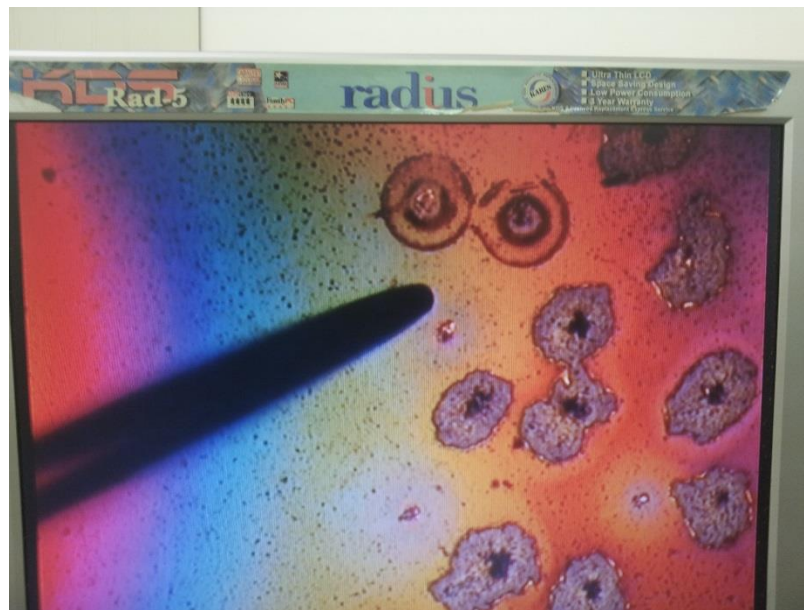

Figure 3.4. Picture of the Pd tip Model 10 probe on top of the Co₃O₄. Several damaged mem-devices are seen surrounding the

A successful formation of a mem-device causes it to start off in the LRS. At this point the metallic filament that creates the mem-device device is not yet set. The device is considered unstable, and simply measuring the mem-device at this time could cause it to break down into an unknown state. For this reason, the mem-device is switched several times between the HRS and LRS.

After the mem-device is conditioned, and deemed stable it can now be measured. The mem-device is first measured in the HRS, then switched and measured in the LRS. If the results of either of these measurements do not contain many errors, then the measurement process is repeated. If there are too many errors in the results, then the mem-device is switched a couple of times before measuring once more. Measurement ceases after either a) the mem-device stops switching, or b) there are too many results with errors. A new mem-device is then created, and the conditioning and measuring steps are performed once more.

There were several lessons learned during the very beginning of learning how to measure mem-devices with a VNA. There were four major issues with measurement and setup of the VNA: standard open and short for 1-port calibration, port extension, electrostatic discharge, and measuring both LRS and HRS with a single calibration. Each of these major issues will most likely be seen in other similar experiments.

3.3.2.1 Lessons earned – 1-port calibration. For a VNA 1-port calibration, the standard is to perform an open, short, and load to remove any excess RLC components. With this calibration, the VNA is able to measure a range of reflection/reactance. This range is determined by the size of the capacitance of the open standard, and the inductance of the short standard. In the case of the GGB calibration kit, the open capacitance and short inductance were stronger than those of the mem-device.

When the VNA was calibrated with the GGB calibration kit, measurements of the mem-device would give no conclusive results. This was due to size of the capacitance and inductance components when the mem-device was in HRS or LRS, respectively. In order to fix this major issue, the calibration kit was changed to broaden the measurement range of the reflection/reactance.

The open standard was replaced to measuring “open air” or not connecting the micro-probe to anything. The closed standard was replaced with a short between the micro-probe and the substrate of the mem-device. This meant that the closed standard was a measurement of the Au mem-device substrate. With this new calibration standard, the VNA measurement range of the reflection/reactance was in line with that of the mem-device.

3.3.2.2 Lessons learned – port extension. After the calibration standard fix, the resulting data of the mem-device would be opposite of what was expected. Instead of the HRS producing a capacitance it was appearing as an inductor, and the opposite for the LRS. This was due to an 180deg phase change introduced by extra components the calibration step did not remove. To remove the extra RLC components, a port extension was applied to the 1-port calibration.

3.3.2.3 Lessons learned – electrostatic discharge. In order to switch and measure the mem-device, the experiment setup had to switch between a VNA and SMU. This required that the SMA cable to be switched between the two units, during the mem-device formation and switching steps. This necessary process creates a high opportunity for Electrostatic Discharge (ESD) to occur. To remove any ESD, the VNA and SMU had to have a properly connected common ground.

ESD events are important to remove because they can damage a mem-device before it can be created, or cause a mem-device to be switched to an unknown state. A mem-device has two defined states, but can also be pushed into an unknown state that typically introduced unknown capacitance and inductance.

3.3.2.4 Lessons learned – separating LRS and HRS measurements. The extreme difference between the LRS and HRS caused several issues in measuring either of these states with the same calibration. The HRS and LRS usually has a three to six orders magnitude difference in impedance. In the case of the E5601B VNA, this difference prevented a single calibration being useful for both states. Since the experiment setup was focused on the HRS, almost all LRS measurements included extra components. A new calibration technique will need to be re-designed in order to efficiently measure the LRS.

3.3.3. Results. The results from the Pd/Co₃O₄/Au mem-device reveal the equivalent components that represented the mem-device. As predicated, the mem-device showed signs of capacitance in the HRS, and inductance in the LRS. In this paper, the

main focus was measuring the HRS and its capacitance for usage with passive RFID tags. The data gathered for the LRS needs further investigation. The LRS data was mostly comprised of noise or added parasitic components that could not be removed. In some cases, an equivalent circuit for the LRS could be determined.

Figure 7 (b) represents a Nyquist plot of a single LRS result. A fitted circuit depicts that the LRS is a resistor and inductor in a parallel circuit. The measured resistance was between 100Ω to 200Ω , and the inductance was around $5\mu\text{H}$. The majority of the resistance and inductance is being contributed to an unknown lumped sum seen as the black R_c and L_c . It is believed that the inductor in the mem-device is due to the metallic filament. As discussed in Section III, this metallic filament is considered a nano-device and it is uncertain as to how small the inductance, if any, may be.

Figure 7 (a) depicts the results of the HRS on a Nyquist plot. The result shows a semicircle in the UHF range (1 MHz to 1.8 GHz). A semicircle on a Nyquist plot indicates that the equivalent circuit for the HRS is a resistor and capacitor in parallel connection. The resulting resistance was measured between $10\text{K}\Omega$ to $20\text{K}\Omega$ and capacitance was measured between 100fF to 10pF .

The large distribution in capacitance and resistance for the HRS is due to the unknown contact size of the Palladium tipped micro-probe. Figure 7 (c and d) represents the capacitance and resistance distribution from the data sets collected. The micro-probe tip is a flexible wire that has a rough diameter of $125\mu\text{m}$. When the probe tip lands on top of the $\text{Pd}/\text{Co}_3\text{O}_4/\text{Au}$ mem-device, the wire bends and increase the contact size. Since each landing involved contains human error, thus the exact contact size is unknown.

In the case of application toward RF, the $\text{Pd}/\text{Co}_3\text{O}_4/\text{Au}$ mem-device demonstrates impedance in both the HRS and LRS. In order for the mem-device to be used in the proposed impedance matching design, the HRS needed to provide capacitance near the pico-farad range. These first round of results indicate that the $\text{Pd}/\text{Co}_3\text{O}_4/\text{Au}$ mem-device may well be suited for RF applications. Improvements to the experiment setup need to be performed before a final conclusion can be surmised.

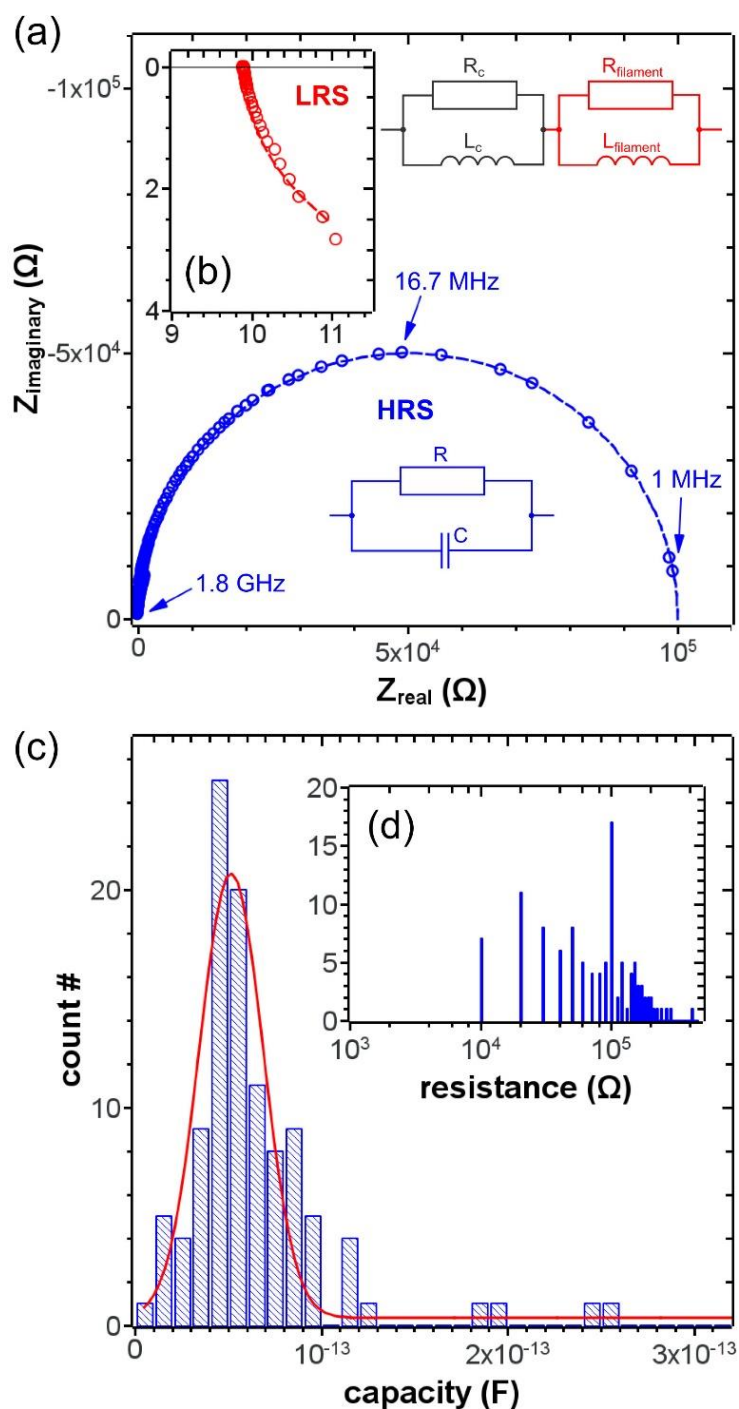

Figure 3.5. Impedance measurements of the cobalt oxide memristive switch for frequencies up to 1.8GHz: (a) Nyquist plot of high resistive state (HRS) with equivalent circuit (blue), (b) Nyquist plot of the low resistive state (LRS) with equivalent circuit (red), (c) Distribution plot of capacitance data produced in the HRS, (d) Distribution plot of the HRS resistance.

3.4. PROPOSED DESIGN OF THE MEMRISTIVE SWITCH-BASED IMPEDANCE NETWORK FOR RF

The results for the Pd/C₃O₄/Au mem-device shows that it is suitable for utilization in passive RFIDs. However, there are several issues that must be solved and much more research before any product can be created. First and foremost control over the contact size of the mem-device needs to be achieved. This will determine if the mem-device can be used independently or as a composed circuit. There are three cases in which the impedance control falls into:

1. If it can be fully controlled giving a fixed capacitance
2. If it can create a repeatable range of capacitance with limited control,
3. If it cannot create a repeatable capacitance or range of capacitance and must rely on fixed additional capacitance.

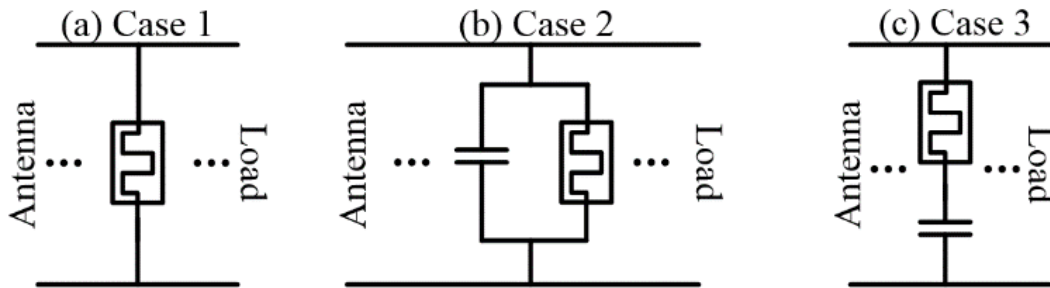

Figure 3.6. High level model of the impedance matching network utilizing different mem-device characteristics. (a) Case 1: If a mem-device has a fixed impedance, than no additional capacitance will be needed. (b) If a mem-device has a controlled impedance range, than capacitance needs to be added in serial or parallel. (c) If a mem-device has no controlled impedance, than the mem-device acts as a switch, turning on impedances.

For Case 1, when the capacitance of the HRS can be controlled through some means than its migration into RF circuits will be less complicated. The mem-device may

be used exclusively without additional capacitors, figure 8 (a). This case gives a great advantage to passive RFID applications, allowing for least amount of energy usage in the impedance matching network. However, the downside of this case will be the additional mem-devices needed in order to create a range of impedances.

For Case 2, the mem-device has a specified range that can be controlled. This represents the first proposed impedance matching circuit seen in figure 8 (b). The mem-device is placed in a capacitive cell parallel/serial to a capacitor. This could be considered the best case scenario with application toward impedance matching networks in passive RFID tags. Since the range of impedance is defined by the mem-device, fewer impedance lanes are needed compared to the first case. Yet, this circuit will require more power due to the additional capacitors.

Case 3 becomes necessary if the mem-device has uncontrollable capacitance. This means that the mem-device has a capacitance but with each switch, the filament changes in some manner that is unpredictable. Figure 8 (c) represents a circuit that may be viable with such a mem-device. Since the capacitance produced is unreliable, the mem-device will have to act as a switch. The impedance of the capacitor cell must be greater than the mem-device in order for the mem-device to not have influence over the total network impedance.

Regardless in all these cases, the Pd/Co₃O₄/Au mem-device will still be ideal for a passive RFID tag impedance matching network. The device requires very little power and continues to keep its state even when power is not present. This allows the passive RFID tag to become a smart tag, remembering its states and matching values without having to spend extra cycles of computation to retrieve such data.

3.5. CONCLUSION

In this paper, the Au/Co₃O₄/Au mem-device is discussed, created, and characterized. The device is able to produce a small amount of capacitive reactance [fF – pF] in the UHF band. This capacitance size is an ideal candidate for the ISN network [45]. A mem-device with impedance can replace the varactors of the ISN Lanes and reduce the power draw of the ISN. In addition, the non-volatile, nano-size, and ability to remember past states will further enhance the passive RFID tag.

A passive RFID tag with an ISN designed with Au/Co₃O₄/Au mem-device will allow for tags in the UHF to be read in dynamic environments. Dynamic environments are time variant and depend on the amount of mutual interference and coupling randomly produced by objects and tags within the environment. The new ISN will be able to dynamically remove the negative effects and create an ideal condition for the tag to respond to the reader, and harvest the maximum amount of power from the reader's signal. These tags will be able to be read when placed in conditions that vary in temperature, and magnetics. Above all, they could be used in applications such as the Internet of Things (IoT) allowing for all goods, products, and tools to be monitored.

BIBLIOGRAPHY

1. Sevinç, Y.; Kaya, A., "Enhancement of ISM band RFID system performance with varactor-loaded compact RFID tag antenna," Microwave Symposium (MMS), 2010 Mediterranean , vol., no., pp.130,134, 25-27 Aug. 2010
2. Kuo, S.-K., Chen, S.-L., Lin, C.-T. "An accurate method for impedance measurement of RFID tag antenna (2008) Progress in Electromagnetics Research", 83, pp. 93-106.
3. Paredes, F., González, G.Z., Bonache, J., Martín, F. "Dual-band impedance-matching networks based on split-ring resonators for applications in RF identification (RFID)" (2010) IEEE Transactions on Microwave Theory and Techniques, 58 (5 PART 1), art. no. 5451087, pp. 1159-1166.
4. Loo, C.-H., Elmahgoub, K., Yang, F., Elsherbeni, A., Kajfez, D., Kishk, A., Elsherbeni, T., Ukkonen, L., Sydänheimo, L., Kivikoski, M., Merilampi, S., Ruuskanen, P. "Chip impedance matching for UHF RFID tag antenna design" (2008) Progress in Electromagnetics Research, 81, pp. 359-370.
5. Rao, K.V.S., Nikitin, P.V., Lam, S.F. "Impedance matching concepts in RFID transponder design" (2005) Proceedings - Fourth IEEE Workshop on Automatic Identification Advanced Technologies, AUTO ID 2005, 2005, art. no. 1544398, pp. 39-42.
6. Marrocco, G. "The art of UHF RFID antenna design: Impedance-matching and size-reduction techniques", (2008) IEEE Antennas and Propagation Magazine, 50 (1), pp. 66-79.
7. Souryal, M.R., Novotny, D.R., Kuester, D.G., Guerrieri, J.R., Remley, K.A. "Impact of RF interference between a passive RFID system and a frequency hopping communications system in the 900 MHz ISM band", (2010) IEEE International Symposium on Electromagnetic Compatibility, art. no. 5711325, pp. 495-500.
8. Lee, H., Kim, S., De Donno, D., Tentzeris, M.M. "A novel Universal inkjet-printed EBG-backed flexible RFID for rugged on-body and metal mounted applications" (2012) IEEE MTT-S International Microwave Symposium Digest, art. no. 6259728
9. Son, H.-W., Choi, G.-Y., Pyo, C.-S. "Design of wideband RFID tag antenna for metallic surfaces" (2006) Electronics Letters, 42 (5), pp. 263-265.

10. Chen, H.-D., Kuo, S.-H., Sim, C.-Y.-D., Tsai, C.-H. “*Coupling-feed circularly polarized RFID tag antenna mountable on metallic surface*” (2012) IEEE Transactions on Antennas and Propagation, 60 (5), art. no. 6163358, pp. 2166-2174.
11. Chen, S.-L., Lin, K.-H. “*A slim RFID tag antenna design for metallic object applications*” (2008) IEEE Antennas and Wireless Propagation Letters, 7, art. no. 2009473, pp. 729-732.
12. Chen, S.-L., Kuo, S.-K., Lin, C.-T. “*A metallic RFID tag design for steel-bar and wire-rod management application in the steel industry*” (2009) Progress in Electromagnetics Research, 91, pp. 195-212.
13. Kim, K.-H., Song, J.-G., Kim, D.-H., Hu, H.-S., Park, J.-H. “*Fork-shaped RFID tag antenna mountable on metallic surfaces*” (2007) Electronics Letters, 43 (25), pp. 1400-1402
14. Son, H.-W., Choi, G.-Y. “*Orthogonally proximity-coupled patch antenna for a passive RFID TAG on metallic surfaces*” (2007) Microwave and Optical Technology Letters, 49 (3), pp. 715-717.
15. Lu, F., Chen, X., Ye, T.T. “*Performance analysis of stacked RFID tags*” (2009) 2009 IEEE International Conference on RFID, RFID 2009, art. no. 4911194, pp. 330-337
16. Cho, C., Choo, H., Park, I. “*Design of planar RFID tag antenna for metallic objects*” (2008) Electronics Letters, 44 (3), pp. 175-177.
17. Chen, H.-D., Tsao, Y.-H. “*Low-profile PIFA Array antennas for UHF band RFID tags mountable on metallic objects*” (2010) IEEE Transactions on Antennas and Propagation, 58 (4), art. no. 5398866, pp. 1087-1092.
18. Liu, J., Chen, L. “*Placement of multiple RFID reader antennas to alleviate the negative effect of tag orientation*” (2012) Proceedings of the International Conference on Parallel and Distributed Systems - ICPADS, art. no. 6413666, pp. 432-439.
19. Choi, W., Kim, J.-S., Bae, J.-H., Choi, G., Chae, J.-S. “*Near-field antenna for RFID smart shelf in UHF*” (2009) IEEE Antennas and Propagation Society, AP-S International Symposium (Digest), art. no. 5171866
20. Boryssenko, A., Boryssenko, E. “*Antenna array design for HF RFID smart cabinet*” (2011) 2011 IEEE International Conference on Microwaves, Communications, Antennas and Electronic Systems, COMCAS 2011, art. no. 6105875

21. Ukkonen, L., Sydänheimo, L., Kivikoski, M. "Effects of metallic plate size on the performance of microstrip patch-type tag antennas for passive RFID" (2005) IEEE Antennas and Wireless Propagation Letters, 4 (1), pp. 410-413.
22. Liu, H., Bolic, M., Nayak, A., Stojmenović, I. "Taxonomy and challenges of the integration of RFID and wireless sensor networks" (2008) IEEE Network, 22 (6), pp. 26-32.
23. Asl, S.E.; Ghasr, M.T.; Zawodniok, M.; Robinson, K.E., "Preliminary study of mutual coupling effect on a passive RFID antenna array," Instrumentation and Measurement Technology Conference (I2MTC), 2013 IEEE International , vol., no., pp.138,141, 6-9 May 2013
24. Ahmed Mohammad Ashry, "CMOS RF-ID Design", Master Thesis, Ain Shams University, 2004.
25. Soylemezoglu, A., Zawodniok, M.J., Jagannathan, S. "RFID-based smart freezer" (2009) IEEE Transactions on Industrial Electronics, 56 (7), pp. 2347-235
26. Fan Jiang, Donghui Guo and L L Cheng "Analysis and Design of Power Generator on Passive RFID Transponders", Progress In Electromagnetics Research Symposium, Hangzhou, China, March 24-28, 2008
27. Zheng, Z., B. Jamal, and P. H. Cole, "Brief comparison of different rectifier structures for RFID transponders".
<http://www.mlab.ch/autoid/SwissReWorkshop/papers/BriefComparisonOfRectifierStructuresForRFIDtransponders.pdf>.
28. Lu, C. and Y.-M. Li, "The RF interface circuits design of contactless IC cards," 4th International Conference on ASIC", 278-280, Shanghai, China, 2001
29. A. Facen, A. Boni, "Power Supply Generation in CMOS passive UHF RFID tags", IEEE research in micro-electronics and electronics 2006, Ph.D
30. Klapf Christian, Missoni Albert, Holweg Gerald, Hofer Günter, Kargl Walter, "Concept for providing a supply voltage and load modulation in a transponder", German Patent Application No. 102007 004 843.4
31. Pavel V. Nikitin, Member, IEEE, K. V. Seshagiri Rao, Senior Member, IEEE, Sander F. Lam, Vijay Pillai, Member, IEEE, Rene Martinez, and Harley Heinrich, "Power Reflection Coefficient Analysis for Complex Impedances in RFID Tag Design", IEEE TRANSACTIONS ON MICROWAVE THEORY AND TECHNIQUES, VOL. 53, NO. 9, SEPTEMBER 2005

32. F. Fuschini, C. Piersanti, F. Paolazzi, and G. Falciasecca, "Analytical approach to the backscattering from UHF RFID transponders," *IEEE Antennas Wireless Propag. Lett.*, vol. 7, pp. 33–35, 2008.
33. Chua, L. O.: "Memristor-the missing circuit element. *Circuit Theory*", *IEEE Transactions*, vol.18, pp.507-519, 1971.
34. Di Ventra, M.; Pershin, Y.V.; Chua, L.O., "Circuit Elements With Memory: Memristors, Memcapacitors, and Meminductors," *Proceedings of the IEEE* , vol.97, no.10, pp.1717,1724, Oct. 2009 doi: 10.1109/JPROC.2009.2021077
35. Strukov, D. B.; Snider, G. S.; Stewart, D. R.; Williams, R. S.: "The missing memristor found", *Nature* vol.453, pp.80-83, 2008.
36. Moon-Que Lee: "Lumped directional coupler with a varactor tuned reflector for RFID applications". *IEICE Electronics Express*, Vol.6, No.2, 129-134.
37. Chang-Sin Son; Jun-Seok Park; Hong-Goo Cho; Lim, Jae-Bong, "A novel variable-impedance microstrip circuit and its application to direct antenna modulation," *Microwave Conference, 2005 European* , vol.3, no., pp.4 pp., 4-6 Oct. 2005
38. Chaobei, Li Chauandong Li, Tingwen Huang, Hui Wang: "SynaPdic memcapacitor bridge synapses". *Neurocomputing* 112 (2013) 370-374
39. Flak, J., "CNN cell with memcapacitive synapses and threshold control circuit," *Cellular Nanoscale Networks and Their Applications (CNNA)*, 2012 13th International Workshop on , vol., no., pp.1,5, 29-31 Aug. 2012 doi: 10.1109/CNNA.2012.6334141
40. Beiwei Zhang Kunyuan Hu Yunlong Zhu "Network architecture and energy analysis of the integration of RFID and Wireless Sensor Network", *Control and Decision Conference (CCDC)*, May 2010, Page(s): 1379 – 1382.
41. Oka, A., Lampe, L. , "Distributed target tracking using signal strength measurements by a wireless sensor network, Selected Areas in Communications," *IEEE Journal*, Sepdember 2010, Volume 28 , Issue:7 , Page(s): 1006 – 1015.
42. Jaekyu Cho ; Yoonbo Shim ; Taekyoung Kwon ; Yanghee Choi , "SARIF: A novel framework for integrating wireless sensor and RFID networks", *IEEE Wireless Communications* , December 2007 , Volume : 14 , Issue:6 , Page(s): 50 – 56.
43. "Resistive switching behavior of Pd/Mg_{0.2}Zn_{0.8}O/Pd devices for nonvolatile memory applications," Chen, Xinman and Wu, Guangheng and Bao, Dinghua, *Applied Physics Letters*, 93, 093501 (2008)

44. Koza, J.A., Schroen, I.P., Willmering, M.M., Switzer, J.A. “*Electrochemical synthesis and nonvolatile resistance switching of Mn 3O4 thin films*,” (2014) *Chemistry of Materials*, 26 (15), pp. 4425-4432.
45. Harris, G. H., Wellnitz, A., Zawodniok, M. “Impedance Switching Network for RFID Tags in Non-Ideal Environments”
46. Sun, J., Lind, E., Maximov, I., Xu, H.Q. “*Memristive and memcapacitive characteristics of a Au/Ti-HfO 2-InP/InGaAs diode*” (2011) *IEEE Electron Device Letters*, 32 (2), art. no. 5671471, pp. 131-133.
47. Vourkas, I., Sirakoulis, G.C. “*Memristor-based combinational circuits: A design methodology for encoders/decoders*” (2014) *Microelectronics Journal*, 45 (1), pp. 59-70.
48. Yan, Z.B., Liu, J.-M. “Coexistence of high performance resistance and capacitance memory based on multilayered metal-oxide structures” (2013) *Scientific Reports*, 3, art. no. 2482.
49. Qingjiang, L., Khiat, A., Salaoru, I., Papavassiliou, C., Hui, X., Prodromakis, T. “*Memory impedance in TiO2 based metal-insulator-metal Devices*” (2014) *Scientific Reports*, 4, art. no. 4522, .
50. Di Ventra, M., Pershin, Y.V. “*On the physical properties of memristive, memcapacitive and meminductive systems*” (2013) *Nanotechnology*, 24 (25), art. no. 255201, .
51. Rao, K.V.S., Nikitin, P.V., Lam, S.F. “*Antenna design for UHF RFID tags: A review and a practical application*,” (2005) *IEEE Transactions on Antennas and Propagation*, 53 (12), pp.3870-3876.
52. Snider, G., Kuekes, P., Hogg, T., Williams, R.S. “*Nanoelectronic architectures*” (2005) *Applied Physics A: Materials Science and Processing*, 80 (6), pp. 1183-1195.
53. Cong, J., Xiao, B. “*mrFPGA: A novel FPGA architecture with memristor-based reconfiguration*” (2011) *Proceedings of the 2011 IEEE/ACM International Symposium on Nanoscale Architectures, NANOARCH 2011*, art. no. 5941476, pp. 1-8.
54. Hasan, R., Taha, T.M. “*Memristor crossbar based programmable interconnects*” (2014) *Proceedings of IEEE Computer Society Annual Symposium on VLSI, ISVLSI*, art. no. 6903342, pp.

55. Itoh, M., Chua, L.O. “*Memristor oscillators*” (2008) *International Journal of Bifurcation and Chaos*, 18 (11), pp. 3183-3206.
56. Sheri, A.M., Hwang, H., Jeon, M., Lee, B.-G. “*Neuromorphic character recognition system with two PCMO memristors as a synapse*” (2014) *IEEE Transactions on Industrial Electronics*, 61 (6), art. no. 6573409, pp. 2933-2941.

VITA

George Harris is currently a Masters Research Student at Missouri University of Science and Technology with an emphasis in Computer Architecture and RF Hardware. He has worked on several projects that involve RF Application and Devices, Computer Architecture, and Nano-devices. Each of these research projects have been catered to improving the impedance balancing for passive RFID tags for their use in metal rich environments. His findings have been presented at the Annual IMS conference in December of 2014. In August of 2015, he received his MS in Computer Engineering from Missouri University of Science and Technology.