

---

Masters Theses

Student Theses and Dissertations

---

Spring 2008

## Adaptive modulation for cognitive radios

Gaurav Sharma

Follow this and additional works at: [https://scholarsmine.mst.edu/masters\\_theses](https://scholarsmine.mst.edu/masters_theses)



Part of the [Electrical and Computer Engineering Commons](#)

Department:

---

### Recommended Citation

Sharma, Gaurav, "Adaptive modulation for cognitive radios" (2008). *Masters Theses*. 6831.  
[https://scholarsmine.mst.edu/masters\\_theses/6831](https://scholarsmine.mst.edu/masters_theses/6831)

This thesis is brought to you by Scholars' Mine, a service of the Missouri S&T Library and Learning Resources. This work is protected by U. S. Copyright Law. Unauthorized use including reproduction for redistribution requires the permission of the copyright holder. For more information, please contact [scholarsmine@mst.edu](mailto:scholarsmine@mst.edu).

ADAPTIVE MODULATION FOR COGNITIVE RADIOS

by

GAURAV SHARMA

A THESIS

Presented to the Faculty of the Graduate School of the

UNIVERSITY OF MISSOURI-ROLLA

In Partial Fulfillment of the Requirements for the Degree

MASTER OF SCIENCE IN ELECTRICAL ENGINEERING

2008

Approved by

---

Kurt L. Kosbar, Advisor

---

Steve Grant

---

Randy H. Moss

© 2008

GAURAV SHARMA

All Rights Reserved

## ABSTRACT

This thesis examines the benefits of using adaptive modulation in terms of spectral efficiency and probability of bit error for cognitive radio networks. In channels that fluctuate dynamically over time, systems that are based upon the conventional methods of fixed modulation formats do not perform well. Adaptive modulation provides many parameters that can be adjusted relative to the channel fading, including data rate, transmit power, instantaneous BER, symbol rate, and channel code rate or scheme.

In this thesis, a systematic study on the increase in spectral efficiency obtained by optimally varying combinations of the modulation formats for a cognitive radio is provided. It has been assumed, that the transmitter has a perfect knowledge of the channel conditions and the resulting adaptive modulation system is subject to an average BER constraint. Simulations show how adaptively changing the modulation schemes improves the performance of the system by meeting a BER constraint over a range of SNR.

This thesis also walks through the basic concepts of cognitive radio including its definition and operation. Various techniques of sensing the electromagnetic spectrum for finding possible vacant bands of frequency and the challenges faced therein have also been discussed.

## ACKNOWLEDGEMENTS

This thesis arose as a part of the research that has been done since I came to the University of Missouri – Rolla, in January 2006. Since then, I had worked with a great number of people both directly and indirectly whose contribution in assorted ways to the research has made this thesis deserve a special mention. It is a pleasure to convey my gratitude to them all in my humble acknowledgment.

In the first place I would like to record my gratitude to Dr. Kurt L. Kosbar, my academic advisor, for his supervision, advice, and guidance from the very early stage of this research. Above all and the most needed, he provided me unflinching encouragement and support in various ways. His truly scientist intuition has made him an oasis of ideas and passions in science, which exceptionally inspired and enriched my growth as a student. I am indebted to him more than he knows.

I gratefully acknowledge Dr. Steve Grant and Dr. Randy Moss, my graduate committee members for their advice, supervision, and crucial contribution, which made them a backbone of this thesis. Many thanks go in particular to Dr. Adam Panagos and Chris Potter for their valuable advices and ideas in the start of this research.

Finally, my parents deserve a special mention for their inseparable support and prayers. They put the fundamentals of learning in me, showing me the joy of intellectual pursuit ever since I was a child. Words fail me to express my appreciation to my wonderful girlfriend Sushmita whose dedication, love, and persistent confidence in me, has taken the load off my shoulder. I owe her for being unselfishly letting her intelligence, passions, and ambitions collide with mine.

## TABLE OF CONTENTS

	Page
ABSTRACT .....	iii
ACKNOWLEDGEMENTS.....	iv
LIST OF ILLUSTRATIONS.....	vii
 SECTION	
1. INTRODUCTION.....	1
2. DEFINITION OF A COGNITIVE RADIO.....	4
3. OPERATION OF A COGNITIVE RADIO.....	6
3.1. STAGES OF OPERATION.....	6
3.2. THE COGNITION CYCLE.....	6
3.3. GAME THEORY AND COGNITIVE RADIO.....	9
3.3.1. Game Theory.....	9
3.3.2. Applying Game Theory to Cognitive Radios.....	10
4. PHYSICAL ARCHITECTURE OF A COGNITIVE RADIO.....	12
5. SPECTRUM SENSING.....	15
5.1. SPECTRUM SENSING TECHNIQUES.....	15
5.1.1. The Matched Filter Method of Signal Detection.....	15
5.1.2. The Radiometric Method of Energy Detection.....	16
5.1.3. The Cyclo-Stationary Feature Detection Method.....	17
5.2. SPECTRUM SENSING CHALLENGES.....	18
5.2.1. Interference Temperature Measurement.....	18
5.2.2. Spectrum Sensing in Multi-user Networks.....	19

5.2.3. Detection Capability.....	19
5.2.4. The Hidden Terminal Problem.....	20
5.3. SPECTRUM MOBILITY.....	21
6. ADAPTIVE MODULATION.....	23
6.1. DOPPLER EFFECT.....	23
6.2. MULTI-PATH PROPAGATION.....	25
6.2.1. Additive White Gaussian Noise (AWGN) Channel.....	26
6.2.2. Rayleigh Fading Channel.....	26
6.3. ADAPTIVE MODULATION TECHNIQUES.....	27
6.4. ADAPTIVE MODULATION MODEL FOR COGNITIVE RADIO.....	29
6.5. MATHEMATICAL MODEL FOR A FADING CHANNEL.....	31
6.6. BIT-ERROR RATE EXPRESSIONS.....	34
6.6.1. BER Expressions for AWGN Channel.....	34
6.6.2. BER Expressions for Rayleigh Fading Channel.....	36
7. SIMULATIONS AND RESULTS.....	37
7.1. BER PERFORMANCE CURVES FOR AWGN CHANNE.....	37
7.2. BER PERFORMANCE CURVES FOR RAYLEIGH FADING CHANNEL.....	38
7.3. OPTIMAL MODULATION FORMATS IN ADAPTIVE MODULATION.....	39
8. CONCLUSION.....	43
BIBLIOGRAPHY.....	44
VITA.....	46

## LIST OF ILLUSTRATIONS

Figure	Page
3.1 The Cognition Cycle.....	8
4.1 Physical Architecture of a Cognitive Radio.....	13
5.1 Implementation of an Energy Detector.....	16
5.2 Implementation of a Cyclo-Stationary Feature Detector.....	18
5.3 The Hidden Terminal problem.....	20
6.1 Illustration of Doppler Effect.....	24
6.2 Model of an Additive White Gaussian Noise (AWGN) channel.....	27
6.3 A typical Rayleigh fading envelope at a carrier frequency of 900 MHz and receiver speed=100km/hr.....	28
6.4 Basic block diagram of an Adaptive Modulation based Cognitive Radio system.....	30
7.1 BER performance of BPSK, QPSK, square 16-QAM, and square 64-QAM in AWGN channel.....	37
7.2 BER performance of 4-AM, 8-AM, and 16-AM in AWGN channel.....	38
7.3 BER performance of BPSK, 4-QAM, 16-QAM, and 64-QAM in Rayleigh flat fading channel.....	39
7.4 Optimal modulation formats in adaptive modulation for BPSK, QPSK, 16-QAM, and 64-QAM in AWGN channel.....	40
7.5 Optimal modulation formats in adaptive modulation for 4-AM, 8-AM, and 16-AM in AWGN channel.....	42
7.6 Optimal modulation formats in adaptive modulation for BPSK, 4-QAM, 16-QAM, and 64-QAM in flat fading Rayleigh channel.....	42



## 1. INTRODUCTION

Commonly used radio systems are often characterized by a fixed spectrum assignment policy, by regulatory agencies like the Federal Communications Commission (FCC). These systems do not monitor the electromagnetic environment around them. However, if these systems choose not to transmit, the bands of frequencies they operate in remain vacant. Measurements show that a large portion of the allocated spectrum is sporadically used, and geographical variations in the utilization of the assigned spectrum ranges from about 15%-85%, with a high variance [1, 2]. These unused bands of frequencies, often referred to as spectrum holes, allow for a new communication paradigm, which can exploit the existing wireless spectrum opportunistically. This paradigm is often called a cognitive radio Network. In situations where most of the electromagnetic spectrum remains unoccupied, cognitive radios can add new dimensions to sharing the spectrum and utilizing it to the maximum.

By having knowledge about their RF local environment, cognitive radios can improve the link reliability, and help wireless systems improve both capacity and coverage. Legacy system interoperability can be achieved when radios learn to autonomously negotiate services and protocols. Intelligent collaborative signaling techniques promise significant range extension and increased data rate. Autonomous determination of spectrum availability and bandwidth requirements will greatly enhance the opportunities for rapid reallocation of spectrum resources.

Dr. Joseph Mitola III of the Virginia Tech coined the term cognitive radio *as a way to efficiently use* the wasted frequency spectrum. He also described how a cognitive

radio could enhance the flexibility of personal wireless services through a new language called the Radio Knowledge Representation Language (RKRL) [3]. Mitola expanded the concept of RKRL in his PhD dissertation [4] presented at the Royal Institute of Technology, Stockholm, Sweden, in May 2000. The dissertation describes the conceptual overview of cognitive radio as an exciting multidisciplinary subject.

This thesis focuses on the ideas and concepts of adaptive modulation, which can be used in cognitive radio networks to achieve an efficient means of communication. Conventional wireless communication systems based upon fixed modulation schemes do not perform well in channels whose coefficients fluctuate randomly. By adaptively altering the modulation schemes for transmission in a cognitive radio system, a higher throughput, an acceptable Bit-Error rate, and a better quality of service can be achieved in dynamically changing channel conditions. Although rapid variations in channel conditions with respect to time pose challenges to the appropriate functioning of adaptive modulation based systems, researchers believe that they are at least a step above the traditional systems based on fixed modulation formats.

Further, this thesis summarizes the basic concepts behind cognitive radios. It walks through the problems of fixed spectrum allocation methods. It discusses about how the use of cognitive radios will overcome the spectrum scarcity problems. The game theoretic approach of defining the functioning of a cognitive radio has also been analyzed. The thesis also discusses the basic spectrum sensing techniques, like the matched filter method of signal detection, the radiometric method of energy detection, and the cyclo-stationary feature detection method. It also discusses the challenges and drawbacks of all these methods of signal detection. The thesis further describes the basic

concepts involved with adaptive modulation and how these concepts can be incorporated in a cognitive radio system to improve performance at a given BER constraint. The thesis also contains of graphs showing optimal modulation formats for adaptive modulation based systems.

## 2. DEFINITION OF A COGNITIVE RADIO

In [5], the author defines a cognitive radio as: “an intelligent wireless communication system that is aware of its environment, and uses the understanding-by-building methodology to learn from the environment and adapt to statistical variations in the input stimuli. The two primary objectives are:

- 1) Highly reliable communication whenever and wherever needed;
- 2) Efficient utilization of the radio spectrum.”

Coming from a background where regulations focus on the operation of transmitters, the FCC defines a cognitive radio as [6]: “A radio that can change its transmitter parameters based on the interaction with the environment in which it operates.”

The IEEE tasked the IEEE 1900.1 group to define cognitive radio, which came up with the following definition [7]: “A type of radio that can sense and autonomously reason about its environment and adapt accordingly. This radio could employ knowledge representation, automated reasoning, and machine learning mechanisms in establishing, conducting, or terminating communication or networking functions with other radios. Cognitive radios can be trained to dynamically and autonomously adjust its operating parameters.”

To summarize, cognitive radios are wireless systems, where the communication does not occur in a fixed or an assigned band of frequency. The radios continuously sense the immediate Radio Frequency (RF) environment and operate in a band that is available and appropriate, dynamically adjusting their frequency, modulation, power, coding, and other parameters to efficiently utilize vacant spectrum while at the same time while at the

same time avoiding interference to existing systems. They are new models of communication system that are clever enough to work through any kinds of interferences.

All of these definitions of cognitive radio assume that cognition will be implemented as a control process, as part of a software defined radio, and imply some capability of autonomous operation. The following are some general capabilities found in most of the definitions:

- 1) **Observation:** whether directly or indirectly, the radio is capable of acquiring information about its operating RF environment.
- 2) **Adaptability:** the radio is capable of adapting to different electromagnetic environments and different channel conditions.
- 3) **Intelligence:** the radio has the ability to apply information towards a specific goal, such as improved performance.

### **3. OPERATION OF A COGNITIVE RADIO**

#### **3.1. STAGES OF OPERATION**

The operation of a cognitive radio can be divided into the following three steps [5]:

- 1) Radio-scene analysis stage, where the following tasks are done
  - Estimation of the interference temperature of the radio environment
  - Detection of spectrum holes
- 2) Channel identification stage, consists of the following tasks
  - Estimation of the channel state information (CSI)
  - Prediction of the channel capacity for use by the transmitter
- 3) Transmit-power control and dynamic spectrum management stage, where the task is
  - To develop an adaptive strategy for the efficient and effective utilization of the RF spectrum
  - To select a proper modulation strategy that adapts to the time-varying nature of the channel to achieve reliable communication.

The first and the second stages of a cognitive radio operation take place on the receiver side and the third stage of the cognitive radio operation takes place on the transmitter side [5].

#### **3.2. THE COGNITION CYCLE**

The cognitive cycle is a process that resides in the cognitive radio, and defines how the radio learns about, and reacts to, its operating environment. The cognitive capability of a cognitive radio enables real-time interaction with its environment, to

determine appropriate communication parameters and adapt to the dynamic radio environment. The three main steps of the cognitive cycle are: spectrum sensing, spectrum analysis, and spectrum decision.

- 1) **Spectrum Sensing:** A cognitive radio monitors the available spectral bands, captures their information, and detects the spectrum holes.
- 2) **Spectrum Analysis:** The characteristics of the spectrum holes that are detected through spectrum sensing are estimated. All of this takes place at the receiver .
- 3) **Spectrum Decision:** A cognitive radio determines the data rate, the transmission mode, and the bandwidth of the transmission at the transmitter. The appropriate spectrum band is chosen according to the spectrum characteristics, and user requirements.

Once the operating spectrum band is determined, the communication can be performed over this band. However, since the radio environment changes over time and geographic location, the cognitive radio needs to track changes in the radio environment. If the spectrum band in use becomes unavailable, the cognitive radios look for another spectrum hole for transmission. Any environmental changes during the transmission like the appearance of the primary user, user movement, or traffic variation can trigger adjustments in the transmission parameters of the cognitive radio.

Figure 3.1 shows the basic form of a cognition cycle. In the cognition cycle, the antennas of a cognitive radio measure the immediate RF environment and receive information about its operating conditions. This information is then evaluated for its importance for the operation of the radio. Based on the evaluation, the radio determines its alternatives and chooses an alternative in a way that would preferably improve the

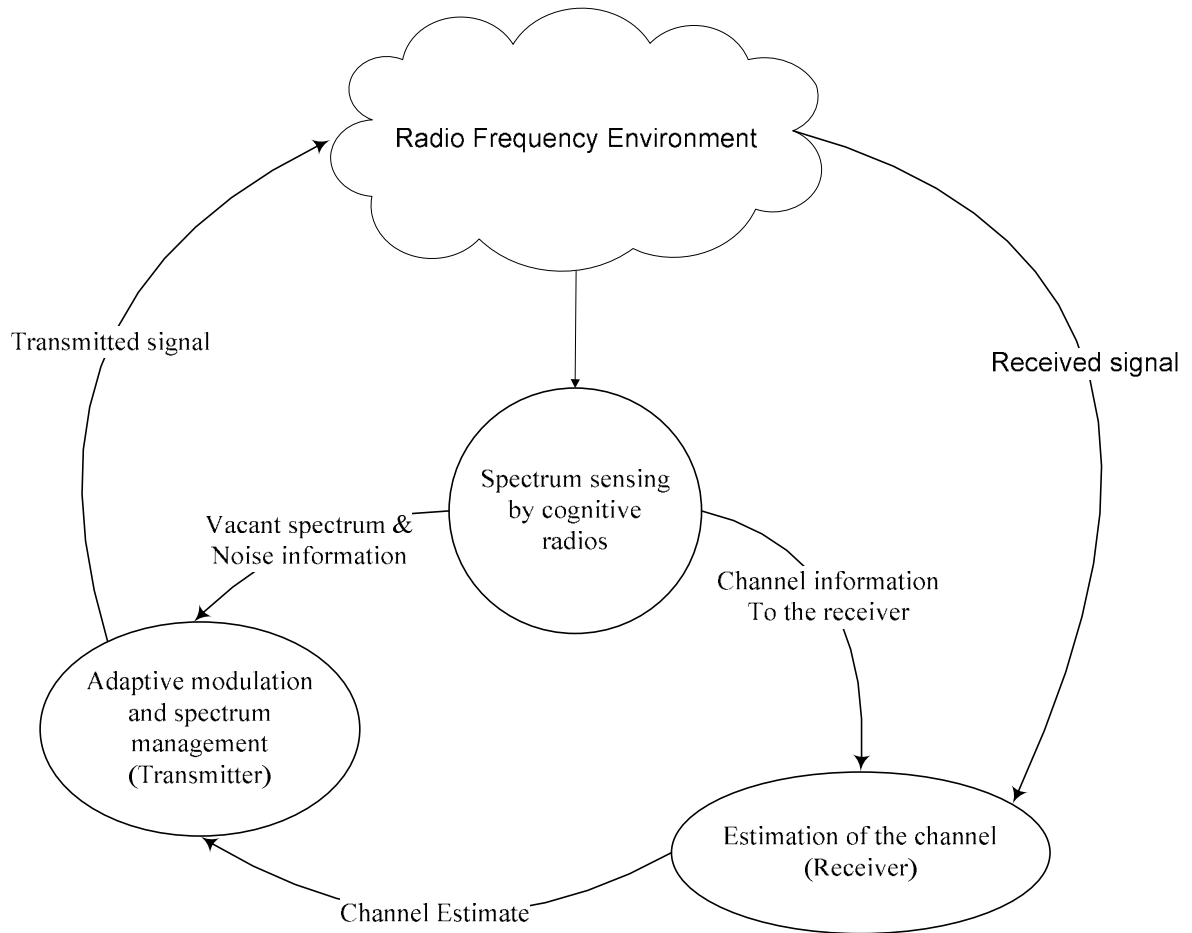

Figure 3.1. The Cognition Cycle

performance of the radio. The radio then adaptively adjusts its resources to implement the alternatives. These changes are then reflected in the interference profile presented by the cognitive radio to the outside radio environment. Throughout this process, the cognitive radio uses the observations and decisions, and learns to improve its operation by creating new modeling states, generating new alternatives, or creating new valuations [8].

From this discussion it is apparent that transmitters of a cognitive radio system must work harmoniously with the cognitive radio receivers. In order to attain this kind of



synchronization between the transmitter and the receiver of a cognitive radio module, a feedback channel that connects the transmitting end and the receiving end is necessary. The receiver is enabled to convey the information on the performance of the forward link to the transmitter through this feedback channel. Cognitive radio technology accommodates a scale of differing degrees of cognition [5]. At one end of the scale, a cognitive radio user might just pick a spectrum hole and construct its cognition cycle around that hole. At the other end of the scale, the user may employ multiple implementation technologies to construct a cognition cycle around a wideband spectrum hole or a set of narrowband spectrum holes to provide the best performance in terms of spectrum management and transmit-power control, in the most possible highly secure manner.

### 3.3. GAME THEORY AND COGNITIVE RADIO

**3.3.1. Game Theory.** Game Theory is a set of mathematical tools used to model and analyze different interactive decision processes. The notion of a game is the fundamental concept of the game theory. Expressed in normal form, a game,  $G = \langle N, A, \{u_i\} \rangle$ , has the following three primary components [8]:

- 1) A finite set of decision makers (players), denoted by  $N = \{1, 2, 3, \dots, n\}$ .
- 2) An action space,  $A$ , formed from the Cartesian product of each player's set of actions,  $A = A_1 \times A_2 \times A_3 \times \dots \times A_n$  [8].
- 3) A set of utility functions,  $\{u_i\} = \{u_1, u_2, u_3, \dots, u_n\}$ , that describe the players' preferences over the games' possible outcomes. Outcomes are determined by the

particular action chosen by player  $i$ ,  $a_i$ , and the particular actions chosen by the other players in the game,  $a_{-i}$ . [8]

In the game, players are assumed to act in their own self-interest, that is to say, each player chooses its actions in such a way that increases the number returned from its utility function. Typically, normal form games are analyzed to identify steady-states known as the Nash Equilibria. A particular action tuple,  $a^*$  in  $A$  is said to be in Nash equilibrium if no player can improve its payoff,  $u_i(a^*)$ , by unilaterally changing its action. [8]

Another typical game model is called the repeated game model. A repeated game is a sequence of stages where each stage is the same normal form game. A repeated game is fully characterized by a stage game, a player function that defines which players are allowed to adapt and play in that stage, and a set of decision rules that describe the rules that each player follows to update its decisions when it is that player's turn to play.

**3.3.2. Applying Game Theory to Cognitive Radios.** The cognition cycle in Figure 3.1 can be mapped into a game. The radios in the network are players in the game. The various alternatives available to them about the radio environment, and the channel, form the action set of the radios. The action space is formed by the Cartesian product of the alternatives available to each radio [8]. The observation and orientation steps of the cognitive radio combine to form their utility functions. Loosely, the observation steps provide the player with arguments to evaluate the utility function, and the orientation steps determine the valuations of the utility functions.

The learning step of the cognition cycle has been ignored here. This is the limitation of the normal form game model. The repeated game, with a normal form stage

game, is however appropriate for any cognitive radio adaptations that do not require learning. It is not appropriate for analyzing algorithms that learn. In this case, more advanced game models that incorporate the learning processes, like the Bayesian games should be used. Moreover, game theory is not well suited to games where actions and objectives are not well defined as may be the case when cognitive radios learn over time [8]. Relevant game models that address these issues, like the Potential game model and the Super-modular game model have been discussed in [8] in detail.

#### 4. PHYSICAL ARCHITECTURE OF A COGNITIVE RADIO

The main components of a cognitive radio transceiver are the radio front-end and the baseband processing unit. Each component can be reconfigured via a control bus to adapt to the time-varying RF environment. In the RF front-end, the received signal is amplified, mixed and passed through an A/D converter. In the baseband processing unit, the signal is modulated/demodulated and encoded/decoded. The baseband processing unit of a cognitive radio is similar to existing transceivers.

The novel characteristic of a cognitive radio transceiver is the wideband sensing capability of its RF front-end. This function is mainly related to RF hardware technologies such as wideband antenna, power amplifiers, and adaptive filters. RF hardware for a cognitive radio should be capable of tuning in any segment of a large range of the spectrum. Such spectrum sensing enables real-time measurements of the spectrum information from the radio environment. Generally, a wide band front-end architecture of a cognitive radio shown in Figure 4.1 has the following structures [9]:

- 1) **Low Noise Amplifier (LNA):** The LNA amplifies the desired signal and simultaneously minimizes the noise component.
- 2) **RF Filter:** The RF filter selects the desired band using a band pass filter at the receiver.
- 3) **Mixer:** The mixer multiplies the received signal with a locally generated RF signal and converts it to the baseband or the intermediate frequency (IF) signal.
- 4) **Voltage Controlled Oscillator (VCO):** The VCO generates a sinusoid to multiply the received signal, and convert it to either an IF or baseband signal.

- 5) **Phase Locked Loop (PLL):** The primary task of a PLL is to ensure that the signal is locked at a specific frequency and to generate precise frequencies with fine resolution.

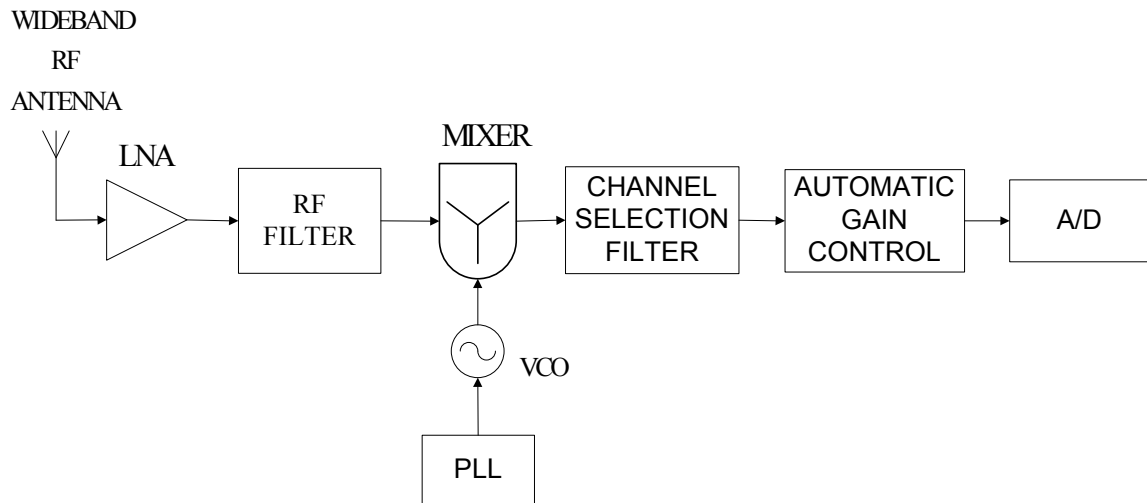

Figure 4.1. Physical Architecture of a Cognitive Radio

- 6) **Channel Selection Filter:** The channel selection filter is used to select the desired channel and to reject other unwanted channels.
- 7) **Automatic Gain Control (AGC):** The AGC is used to maintain a constant output power level of an amplifier over a wide range of input signal levels.

In this architecture, a wideband signal is received through the RF front-end, sampled by the high speed analog-to-digital (A/D) converter, and measurements are performed for the detection of the licensed user signal. However, there exist a few limitations in developing the cognitive radio front-end. The wideband RF antennas receive signals from various transmitters operating at different power levels, bandwidths,

and locations. As a result, the RF front-end should have the capability to detect a weak signal in a large dynamic range. However, this capability requires a high speed A/D converter with a high resolution, which might not be feasible.

The requirement of a high speed A/D converter necessitates the dynamic range of the signal to be reduced before A/D conversion. This reduction can be achieved by filtering strong signals. Since strong signals can be located anywhere in the wide spectrum range, tunable notch filters are required for the reduction. Another approach is to use multiple antennas so that signal filtering is performed in the spatial domain rather than in the frequency domain. Multiple antennas can be used to receive signals selectively using beam forming techniques [10].

As just discussed, the key challenge of the physical architecture of the cognitive radio is the accurate detection of weak signals of licensed users over a wide spectrum range. Hence, the implementation of the RF-wideband front-end and A/D converter is a critical issue in cognitive radios.

## 5. SPECTRUM SENSING

### 5.1. SPECTRUM SENSING TECHNIQUES

Several methods have been proposed in research papers about ways of sensing the RF spectrum for vacant bands of frequencies for transmission in cognitive radios. A few of those spectrum sensing techniques discussed in [9] are:

- 1) The Matched Filter Method of Signal Detection
- 2) The Radiometric Method of Energy Detection
- 3) The Cyclo-Stationary Feature Detection Method

**5.1.1. The Matched Filter Method of Signal Detection.** The optimal method for any signal detection is a matched filter method, as it maximizes the received signal-to-noise ratio. However, a matched filter requires effective demodulation of a primary user signal. This means that the cognitive radio has apriori knowledge of the modulation type and order, pulse shaping, packet format, etc., of the primary user signal. Such information might be pre-stored in the memory of the cognitive radio. The challenge however, lies in the demodulation because it has to achieve coherency with the primary user signal by performing both timing and carrier synchronization, and channel equalization. This can still be possible with pilots, preambles, synchronization words, or spreading codes that can be used for coherent detection. However, a significant drawback of the matched filter method of signal detection is that a cognitive radio would require a dedicated receiver for every primary user class [9]. Therefore, the complexity of the matched filter method of signal detection makes it really difficult to be implemented as a spectrum sensing unit in cognitive radios.

**5.1.2. The Radiometric Method of Energy Detection.** One approach to simplify matched filtering method is to perform non-coherent detection using the energy detection method. This sub-optimal technique has been extensively used in radiometry. An energy detector can be implemented similar to a spectrum analyzer by averaging frequency bins of a Fast Fourier Transform (FFT), as shown in Figure 5.1 [9]. The processing gain is proportional to the FFT size  $N$  and the averaging time  $T$ . Increasing  $N$  improves the frequency resolution which facilitates narrowband signal detection. Also, longer averaging time reduces the noise power, thereby increasing the signal-to-noise ratio.

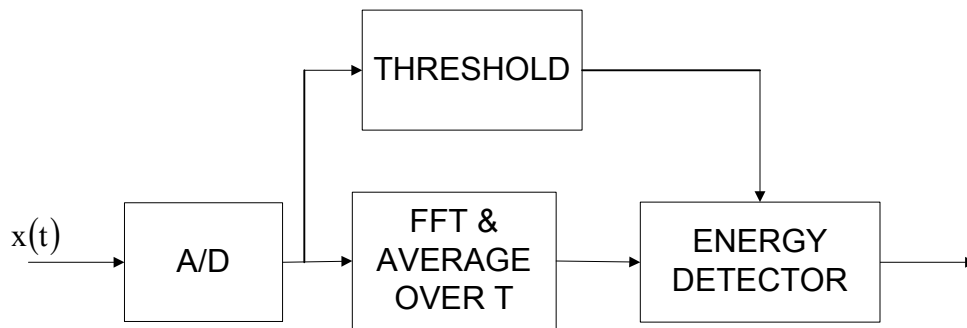

Figure 5.1. Implementation of an Energy Detector

There are several drawbacks of energy detectors that might diminish their simplicity in implementation. First, a threshold used for primary user detection is highly susceptible to unknown or changing noise levels. Even if the threshold is set adaptively, the presence of any in-band interference will confuse the energy detector. Also, in frequency selective fading it is not clear how to set the threshold with respect to channel



notches. Second, the energy detector cannot distinguish between the modulated signals, the noise, and the interference. Since it cannot recognize interference, it cannot benefit from adaptive signal processing for cancelling the interference signal. Lastly, an energy detector does not work for spread spectrum signals: direct sequence and frequency hopping signals, for which more sophisticated signal processing algorithms, need to be devised.

**5.1.3. The Cyclo-Stationary Feature Detection Method.** In general the modulated signals are coupled with sine wave carriers, pulse trains, repeating spreading, hopping sequences, or cyclic prefixes which result in built-in periodicity. Even though the data is a stationary random process, these modulated signals are characterized as cyclo-stationary [9] as their statistics, mean and autocorrelation, exhibit periodicity over time. This periodicity is typically introduced intentionally in the signal format so that a receiver can exploit it for: parameter estimation such as carrier phase, pulse timing, or direction of arrival. This information can then be used for detection of a random signal with a particular modulation type in a background of noise and other modulated signals. The implementation of a cyclo-stationary feature detection method has been shown in Figure 5.2.

Common analysis of stationary random signals is based on autocorrelation function and power spectral density. On the other hand, cyclo-stationary signals exhibit correlation between widely separated spectral components due to spectral redundancy caused by periodicity.

The unique character of spectral redundancy makes signal selection easier [9]. Signal analysis in cyclic spectrum domain preserves phase and frequency information

related to timing parameters in modulated signals. As a result, overlapping features in the power spectrum are non-overlapping features in the cyclic spectrum [9]. Different modulated signals like BPSK, QPSK, and SQPSK that have identical power spectral density functions can have distinct spectral correlation functions. Furthermore, stationary noise and interference signals exhibit no spectral correlation.

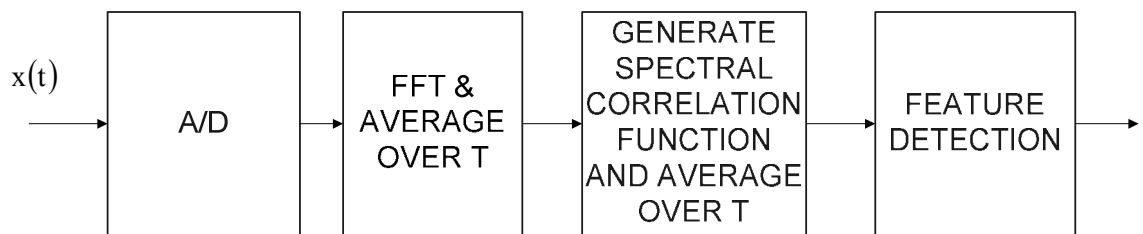

Figure 5.2. Implementation of a Cyclo-Stationary Feature Detector

## 5.2. SPECTRUM SENSING CHALLENGES

There are a few challenges that require extensive research for the development of proper and efficient spectrum sensing techniques. Some of these challenges are discussed briefly in the following sections.

**5.2.1. Interference Temperature Measurement.** The difficulty of a detection model for a receiver lies in effectively measuring the interference temperature. A cognitive radio user is aware of its transmission parameters and its precise location with the help of its positioning system. This ability could however, cause a significant amount of interference at a neighboring receiver on the same frequency. However, to the author's knowledge currently, there does not exist any practical way for a cognitive radio to

measure or estimate the interference temperature at nearby receivers. Due to the fact that primary users are most of the time passive, a cognitive radio cannot be aware of their precise locations. Moreover, if cognitive radio users cannot measure the effect of their transmission on all possible receivers, a useful interference temperature measurement might not be feasible.

**5.2.2. Spectrum Sensing in Multi-user Networks.** Usually, cognitive radio users are found in multi-user environment consisting of numerous primary and secondary users. A cognitive radio user can also be located in the vicinity with another user of its kind competing for the same spectrum band. However, interference models developed to this date do not consider the effect of multi-user environment. Multi-user environment make it more difficult to sense the presence of primary users and to estimate the actual interference temperature. Hence, spectrum sensing techniques that address the problems posed by multi-user network environment need to be developed. In order to solve multi-user issues, cooperative detection schemes can be taken into consideration. These detection schemes exploit the spatial diversity inherent in a multi-user network.

**5.2.3. Detection Capability.** One of the main requirements of cognitive radio networks is the detection of primary users as quickly as possible. Orthogonal Frequency Division Multiplexing (OFDM) based cognitive radio networks are known to be an excellent fit for the architecture of cognitive radio networks [11, 12]. Since, multi-carrier sensing can be exploited in OFDM-based networks the overall sensing time can be reduced. Once a primary user is detected in a single carrier, sensing in other carriers is not necessary. In [11], a power-based sensing algorithm in OFDM networks is proposed for spotting a primary user. It has been shown that the overall detection time is reduced

by collecting information from each carrier. However, this necessitates the use of a large number of carriers, thereby increasing the design complexity. Hence, novel spectrum sensing techniques need to be developed such that the number of samples needed to detect the primary user is minimized within a given probability of detection error.

**5.2.4. The Hidden Terminal Problem.** A cognitive radio might sense a spectral hole and not notice a primary user operating behind a big building transmitting to a tower on a hill, in a particular frequency band as shown in Figure 5.3. Since, the building acts as an obstacle between two cognitive radios, they don't sense the presence of a primary user, in that frequency. Thus, they conclude that the portion of the spectrum is unoccupied and attempt to transmit. This signal from one of the two cognitive radio users

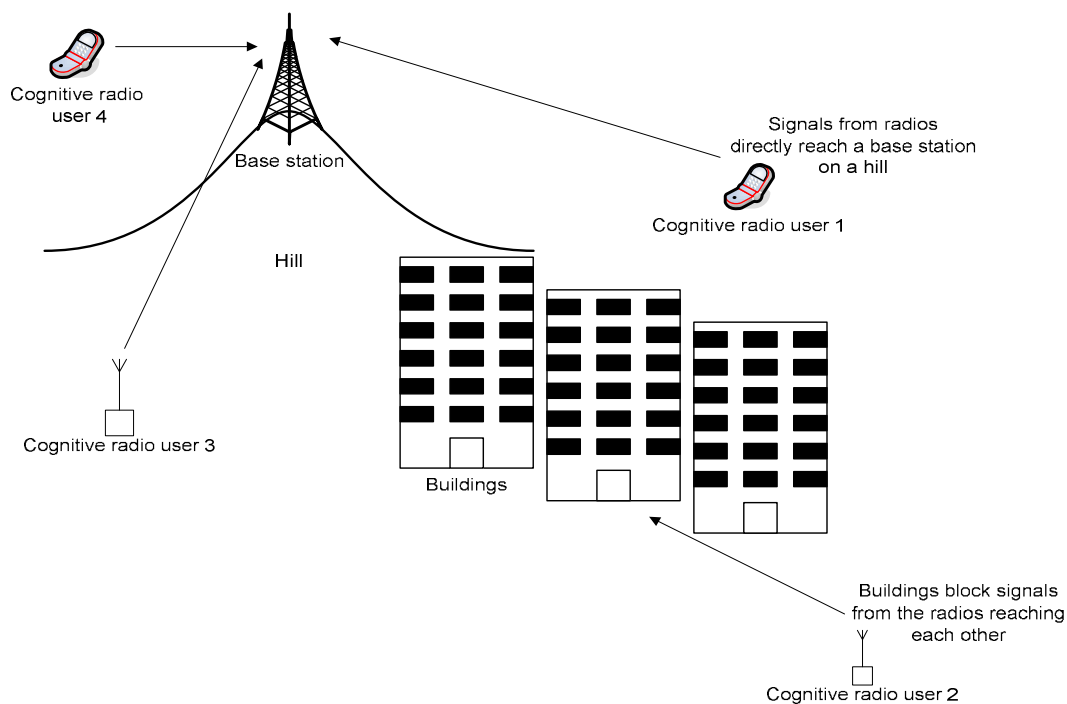

Figure 5.3. The Hidden Terminal Problem

is received as an interference signal at the tower. In spite of the fact that the two cognitive radios are within the communication range of one another, they cannot communicate. This problem is referred to as the Hidden Terminal Problem [13]. The Hidden Terminal Problem can however be solved by the tower on the top of the hill, by transmitting a signal to the cognitive radio users, indicating whether a portion of the spectrum is unoccupied. The users then, send a request to use that band of frequencies to the tower. If the tower sees that a frequency band is free, it indicates to the cognitive radio users and they start to communicate.

### **5.3 SPECTRUM MOBILITY**

Cognitive radios target to use the spectrum in a dynamic manner by allowing the radio terminals to operate in the best available frequency band. This means that the users need to find the best available channel for communication. Spectrum mobility is defined as a process when a cognitive radio changes its frequency of operation. In the section below brief descriptions of the spectrum handoff concepts in cognitive radios are discussed.

**Spectrum Handoff:** In cognitive radio networks, spectrum mobility comes into play when the current channel conditions deteriorate or when the primary user reappears. Spectrum mobility gives rise to a new type of handoff in cognitive radio networks called Spectrum Handoff. The protocols for different layers of the network stack must adapt to the channel parameters of the operating frequency.

As discussed in the earlier sections, a cognitive radio can adapt to the frequency of operation. Therefore, each time a cognitive radio changes its frequency of operation,

the network protocols shift from one mode of operation to another. The purpose of spectrum mobility management in cognitive radio networks is to make sure that such transitions are made smoothly and as quickly as possible such that the applications running in the cognitive radio user perceive minimum degradation of performance during a spectrum handoff.

## 6. ADAPTIVE MODULATION

The channel of a wireless communication system is characterized by Doppler spread and multi-path fading, resulting in random fluctuations in radio channels. These changes result due to rapid alterations in the signal strength over a small travel distance or time interval, random frequency modulation due to varying Doppler shifts on different multi-path signals, and time dispersion caused by multi-path propagation delays [14]. Thus, the system performance is highly dependent on the wireless channel which dynamically varies with respect to time. Adaptive modulation is a technique to exploit the rapid fluctuations in wireless channels to maximize the data throughput in energy and spectral efficient ways. In adaptive modulation, many parameters can be adjusted according to the channel variations such as the transmit-power, modulation level, symbol rate, coding rate, etc.

### 6.1. DOPPLER EFFECT

Due to the relative motion between two radios, each multi-path wave experiences an apparent shift in the frequency. The shift in the received signal frequency due to motion is called the Doppler Shift and the phenomenon referred to as the Doppler Effect [14]. The Doppler shift is directly proportional to the velocity and direction of the motion of the radio with respect to the direction of arrival of the received multi-path wave. This change in frequency of a wave as perceived by an observer moving relative to the source of the waves causes fading in mobile wireless communication systems. Figure 6.1 illustrates the Doppler Effect [14].

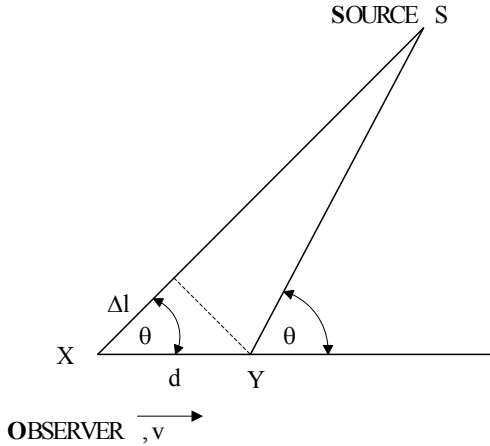

Figure 6.1. Illustration of Doppler Effect

In Figure 6.1, a user is at a point X, moving towards another point Y, with a velocity of  $v$ . Since, the source is at a significant distance from the observer, it is assumed that the angle of arrival of the received signal at all points during transmission is constant. The difference in the distance the transmitted signal must travel between the receiver at points X and Y is given by:

$$\Delta l = v\Delta t \cos \theta. \quad (6.1)$$

The resulting phase change between the points X and Y can then be expressed as:

$$\Delta\Phi = 2\pi \frac{\Delta l}{\lambda} = 2\pi \frac{v\Delta t}{\lambda} \cos \theta \quad (6.2)$$

In (6.2),  $\lambda$  is the wavelength in meters. The apparent change in frequency, or the Doppler shift, is given by  $f_d$  (in Hz), where,



$$f_d = \frac{1}{2\pi} \frac{\Delta\Phi}{\Delta t} = \frac{v}{\lambda} \cos\theta \quad (6.3)$$

It is evident from (6.3) that if the observer is moving towards the direction of arrival of the wave, the Doppler shift is positive, and if the observer is moving away from the direction of the arrival of the wave, the Doppler shift is negative [14].

Equation (6.3) also helps us to conclude that the maximum Doppler shift occurs when  $\theta = 0$ , and is given by  $\frac{v}{\lambda}$ .

## 6.2. MULTI-PATH PROPAGATION

In addition to the Doppler shift, the transmitted signal experiences multi-paths in the channel. The presence of reflecting objects and scatterers in the channel creates a constantly changing environment that dissipates the signal energy in amplitude, phase, and time. This results in multiple versions of the transmitted signal that reach the receiver, displaced with respect to one another in time and spatial orientation. The random phases and the amplitudes of the different multi-path components cause fluctuations in the signal strength, inducing small-scale fading, signal distortion, and/or both. These multi-path components will also have their own Doppler shifts and phase offsets due to different angles of arrival and time delays. The combination of these paths will be constructive or destructive due to different phases causing the signal strength to change with the environment. Multi-paths often increase the time required for the baseband portion of the signal to reach the receiver which can cause signal smearing due to inter-symbol interference [14]. Multi-path propagation along with speed of the mobile

user, speed of surrounding objects, and the transmission bandwidth of the signal are among a few physical factors influencing small-scale fading in wireless communication.

**6.2.1. Additive White Gaussian Noise (AWGN) Channel.** In wireless communication channels the Additive White Gaussian Noise (AWGN) channel is a model in which there is a linear addition of wideband or white noise that has a constant spectral density and a Gaussian distribution of amplitude. The model does not account for the phenomena of fading, frequency selectivity, interference, non-linearity, or dispersion. However, the AWGN channel model produces simple and tractable mathematical models which are beneficial for gaining an insight into the underlying behavior of a system before other complicated phenomena are considered. The received signal after the addition of AWGN channel is given by:

$$X(t) = s_i(t) + W(t) \quad 0 \leq t \leq T; i = 1, 2, 3, \dots \quad (6.4)$$

The channel can therefore be modeled as shown in Figure 6.2, where the noise process  $W(t)$  is represented by the sample function  $w(t)$ , and the received random process  $X(t)$  is represented by the sample function  $x(t)$  of the received signal [15]. The model provides a basis for the design of optimum receivers in wireless systems.

**6.2.2. Rayleigh Fading Channel.** In wireless channels, the Rayleigh distribution is commonly used to describe the statistical time varying nature of the received envelope of a flat fading signal, or the envelope of an individual multi-path component. It is well known that the envelope of the sum of the two quadrature Gaussian noise signal obeys a Rayleigh distribution. The Rayleigh distribution has a probability density function (PDF), as given in [14], by

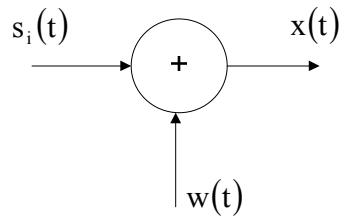

Figure 6.2. Model of an Additive White Gaussian Noise channel

$$P(r) = \frac{r}{\sigma^2} e^{-\frac{r^2}{2\sigma^2}} \quad (0 \leq r \leq \infty) \quad (6.5)$$

Where,  $\sigma$  is the rms value of the received voltage signal before envelope detection, and  $\sigma^2$  is the time-average power of the received signal before envelope detection. The probability that the envelope of the received signal does not exceed a specified value  $R$  is given by the corresponding cumulative distribution function (CDF) in [14]:

$$P(R) = \Pr(r \leq R) = \int_0^R p(r) dr = 1 - e^{-\frac{R^2}{2\sigma^2}} \quad (6.6)$$

Figure 6.3 shows a typical Rayleigh fading envelope at a carrier frequency of 900 MHz, a receiver speed of 100 km/hr, and a corresponding Doppler shift of 300 kHz.

### 6.3. ADAPTIVE MODULATION TECHNIQUES

Adaptive modulation is only appropriate for duplex communication between two or more stations because the transmission parameters have to be adapted using some form

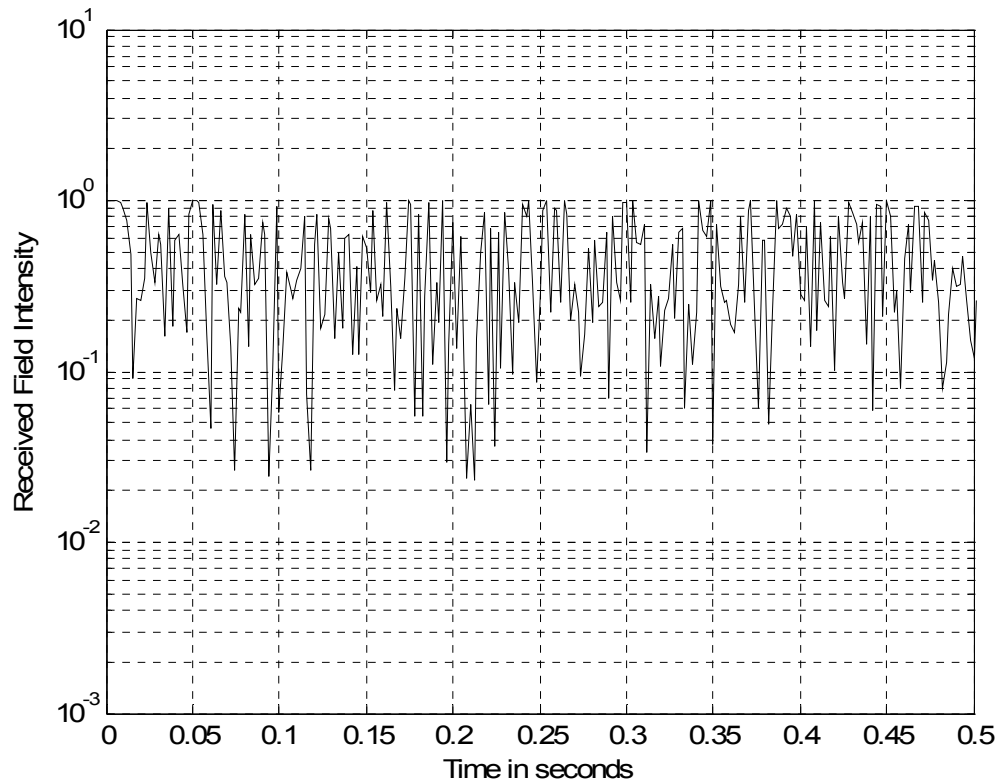

Figure 6.3. A typical Rayleigh fading envelope at a carrier frequency of 900 MHz and receiver speed =100km/hr

of a two-way transmission in order to allow channel measurements and signaling to take place. Transmission parameter adaptation is a response of the transmitter to the time-varying channel conditions. In order to efficiently react to the changes in channel quality, the following steps need to be taken [16]:

- 1) **Channel quality estimation:** To appropriately select the transmission parameters to be employed for the next transmission, a reliable estimation of the channel transfer function during the next active transmit slot is necessary. This is done at

the receiver and the information about the channel quality is sent to the transmitter for next transmission through a feedback channel.

- 2) **Choice of the appropriate parameters for the next transmission:** Based on the prediction of the channel conditions for the next time slot, the transmitter has to select the appropriate modulation modes for the sub-carriers.
- 3) **Signaling or blind detection of the employed parameters:** The receiver has to be informed, as to which demodulator parameters to employ for the received packet.

#### **6.4. ADAPTIVE MODULATION MODEL FOR COGNITIVE RADIO**

In a scenario where channel conditions fluctuate dynamically, systems based on fixed modulation schemes do not perform well, as they cannot take into account the difference in channel conditions. In such a situation, a system that adapts to the worst case scenario would have to be built to offer an acceptable bit-error rate. To achieve a robust and a spectrally efficient communication over multi-path fading channels, adaptive modulation is used, which adapts the transmission scheme to the current channel characteristics. Taking advantage of the time-varying nature of the wireless channels, adaptive modulation based systems alter transmission parameters like power, data rate, coding, and modulation schemes, or any combination of these in accordance with the state of the channel [17]. If the channel can be estimated properly, the transmitter can be easily made to adapt to the current channel conditions by altering the modulation schemes while maintaining a constant BER. This can be typically done by estimating the channel at the receiver and transmitting this estimate back to the transmitter. Thus, with

adaptive modulation, high spectral efficiency can be attained at a given BER in good channel conditions, while a reduction in the throughput is experienced in degrading channel conditions [18]. The basic block diagram of an adaptive modulation based cognitive radio system is shown in Figure 6.4. The block diagram provides a detail view of the whole adaptive modulation system with all the necessary feedback paths.

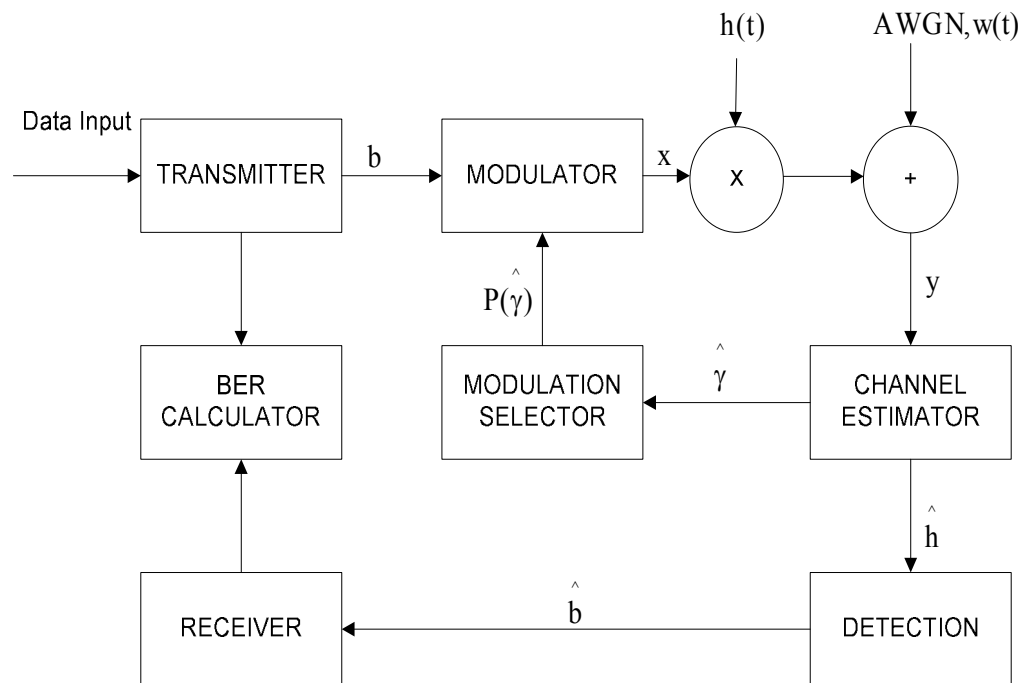

Figure 6.4. Basic block diagram of an Adaptive Modulation based Cognitive Radio system

It is assumed that the transmitter has a perfect knowledge of the channel and the channel estimator at the receiver is error-free and there is no time delay. The receiver uses coherent detection methods to detect signal envelopes. The adaptive modulation, M-ary PSK, M-QAM, and M-ary AM schemes with different modes are provided at the

transmitter. With the assumption that the estimation of the channel is perfect, for each transmission, the mode is adjusted to maximize the data throughput under average BER constraint, based on the instantaneous channel SNR. Based on the perfect knowledge about the channel state information (CSI), at all instants of time, the modes are adjusted to maximize the data throughput under average BER constraint.

The data stream,  $b(t)$  is modulated using a modulation scheme given by  $P_k(\hat{\gamma})$ , the probability of selecting  $k^{\text{th}}$  modulation mode from  $K$  possible modulation schemes available at the transmitter, which is a function of the estimated SNR of the channel. Here,  $h(t)$  is the fading channel and  $w(t)$  is the AWGN channel. At the receiver, the signal can be modeled as:

$$y(t) = h(t)x(t) + w(t) \quad (6.7)$$

Here,  $y(t)$  is the received signal,  $h(t)$  is the fading channel impulse response, and  $w(t)$  is the Additive White Gaussian Noise (AWGN). The estimated current channel information is returned to the transmitter to decide the next modulation scheme. The channel state information,  $\hat{h}(t)$  is also sent to the detection unit to get the detected stream of data,  $\hat{b}(t)$ .

## 6.5. MATHEMATICAL MODEL FOR A FADING CHANNEL

The fading channels are often modeled as Nakagami fading channels [16]. The probability density function (PDF) of the instantaneous channel SNR,  $\gamma$  over a Nakagami fading channel is given by:

$$f(\gamma) = \left(\frac{n}{\bar{\gamma}}\right)^n \frac{\gamma^{n-1}}{\Gamma(n)} \exp\left\{-\frac{n\gamma}{\bar{\gamma}}\right\}, \gamma \geq 0 \quad (6.8)$$

In (6.8),  $n$  governs the severity of the fading,  $\Gamma(n)$  is the Gamma function given by

$$\Gamma(n) = \int_0^{\infty} x^{n-1} \exp\{-x\} dx \quad (6.9)$$

$\bar{\gamma}$  is the mean SNR of the channel. If  $n=1$ , the PDF in (6.8) reduces to the PDF of  $\gamma$  over the Rayleigh fading channel given by:

$$f(\gamma) = \frac{1}{\bar{\gamma}} \exp\left\{-\frac{\gamma}{\bar{\gamma}}\right\} \quad (6.10)$$

As the value of  $n$  increases, the channel behaves like Rician fading, and when  $n$  goes to  $\infty$  the channel reduces to the AWGN channel [16].

Let  $P_k$  be the probability of selecting the  $k^{\text{th}}$  mode from  $K$  possible modulation schemes.

Let  $\xi$  be the channel quality metric. Thus,  $P_k$  can be computed as a function of  $\xi$  as

[16]:

$$P_k = \Pr[l_k \leq \xi \leq l_{k+1}] = \int_{l_k}^{l_{k+1}} f(\xi) d\xi \quad (6.11)$$

In (6.11),  $l_k$  denotes the mode switching levels and  $f(\xi)$  is the PDF of  $\xi$ . The average throughput  $B$  in terms of mean number of Bits per second (BPS) can then be computed from [18]:



$$B = \sum_{k=0}^{K-1} b_k \int_{l_k}^{l_{k+1}} f(\xi) d\xi = \sum_{k=0}^{K-1} b_k P_k \quad (6.12)$$

where  $b_k$  is the throughput of the individual modes. When  $l_k = \infty$ , the average throughput  $B$  can be computed as:

$$B = \sum_{k=0}^{K-1} b_k \int_{l_k}^{l_{k+1}} f(\xi) d\xi = \sum_{k=0}^{K-1} c_k \int_{l_k}^{\infty} f(\xi) d\xi = \sum_{k=0}^{K-1} c_k F_c(l_k) \quad (6.13)$$

where  $F_c(\xi)$  is the complimentary Cumulative Distribution Function (CDF) defined by:

$$F_c(\xi) = \int_{\xi}^{\infty} f(x) dx \quad (6.14)$$

If the instantaneous channel SNR  $\gamma$  is considered to be used as the channel quality measure  $\xi$  in our adaptive modulation scheme over a Nakagami fading channel, the mode selection probability  $P_k$  can be computed from [16]:

$$P_k = \int_{l_k}^{l_{k+1}} f(\gamma) d\gamma = F_c(l_k) - F_c(l_{k+1}) \quad (6.15)$$

where, the complementary CDF  $F_c(\gamma)$  is given by [16]:

$$F_c(\gamma) = \exp\left\{-\frac{n\gamma}{\bar{\gamma}}\right\} \sum_{i=0}^{n-1} \frac{\left(\frac{n\gamma}{\bar{\gamma}}\right)^i}{\Gamma(i+1)} \quad (6.16)$$

In a Rayleigh fading channel, when  $n=1$ , the mode selection probability  $P_k$  from (6.15) is given by [16]:

$$P_k = \exp\left\{-\frac{I_k}{\bar{\gamma}}\right\} - \exp\left\{-\frac{I_{k+1}}{\bar{\gamma}}\right\} \quad (6.17)$$

The average throughput  $B$  of the adaptive modulation scheme transmitting over a Nakagami fading channel is given by [16]:

$$B = \sum_{k=0}^{K-1} c_k \exp\left\{-\frac{nl_k}{\bar{\gamma}}\right\} \left\{ \sum_{i=0}^{n-1} \frac{\left(\frac{nl_k}{\bar{\gamma}}\right)^i}{\Gamma(i+1)} \right\} \quad (6.18)$$

## 6.6. BIT-ERROR RATE EXPRESSIONS

**6.6.1. BER Expressions for AWGN Channel.** The mathematical expressions for the BER performance of BPSK, QPSK, square 16-point QAM, and square 64-point QAM, assuming perfect clock and carrier recovery, in a Gaussian channel are given in [19] as:

$$P_{\text{BPSK}}(\gamma) = Q(\sqrt{2\gamma}) \quad (6.19)$$

$$P_{\text{QPSK}}(\gamma) = Q(\sqrt{\gamma}) \quad (6.20)$$

$$P_{\text{16QAM}}(\gamma) = \frac{1}{4} \left[ Q\left(\sqrt{\frac{\gamma}{5}}\right) + Q\left(3\sqrt{\frac{\gamma}{5}}\right) \right] + \frac{1}{2} Q\left(\sqrt{\frac{\gamma}{5}}\right) \quad (6.21)$$

$$\begin{aligned}
P_{64\text{-QAM}}(\gamma) &= \frac{7}{12}Q\left(\sqrt{\frac{\gamma}{21}}\right) + \frac{1}{2}Q\left(3\sqrt{\frac{\gamma}{21}}\right) - \frac{1}{12}Q\left(5\sqrt{\frac{\gamma}{21}}\right) \\
&\quad + \frac{1}{6}Q\left(9\sqrt{\frac{\gamma}{21}}\right) + \frac{1}{12}Q\left(11\sqrt{\frac{\gamma}{21}}\right) - \frac{1}{12}Q\left(13\sqrt{\frac{\gamma}{21}}\right)
\end{aligned} \tag{6.22}$$

The expressions for BER performance of 4-AM, 8-AM, and 16-AM over AWGN channel are given in [17] as:

$$P_{4\text{-AM}}(\gamma) = \frac{3}{4}Q\left(\sqrt{\frac{2}{5}\gamma}\right) + \frac{1}{2}Q\left(3\sqrt{\frac{2}{5}\gamma}\right) - \frac{1}{4}Q\left(5\sqrt{\frac{2}{5}\gamma}\right) \tag{6.23}$$

$$\begin{aligned}
P_{8\text{-AM}}(\gamma) &= \frac{7}{12}Q\left(\sqrt{\frac{2}{21}\gamma}\right) + \frac{1}{2}Q\left(3\sqrt{\frac{2}{21}\gamma}\right) - \frac{1}{12}Q\left(5\sqrt{\frac{2}{21}\gamma}\right) \\
&\quad + \frac{1}{12}Q\left(9\sqrt{\frac{2}{21}\gamma}\right) - \frac{1}{12}Q\left(13\sqrt{\frac{2}{21}\gamma}\right)
\end{aligned} \tag{6.24}$$

$$\begin{aligned}
P_{16\text{-AM}}(\gamma) &= \frac{15}{32}Q\left(\sqrt{\frac{2}{85}\gamma}\right) + \frac{14}{32}Q\left(3\sqrt{\frac{2}{85}\gamma}\right) + \frac{5}{32}Q\left(5\sqrt{\frac{2}{85}\gamma}\right) \\
&\quad - \frac{6}{32}Q\left(7\sqrt{\frac{2}{85}\gamma}\right) - \frac{7}{32}Q\left(9\sqrt{\frac{2}{85}\gamma}\right) + \frac{6}{32}Q\left(11\sqrt{\frac{2}{85}\gamma}\right) \\
&\quad + \frac{9}{32}Q\left(13\sqrt{\frac{2}{85}\gamma}\right) + \frac{8}{32}Q\left(15\sqrt{\frac{2}{85}\gamma}\right) - \frac{7}{32}Q\left(17\sqrt{\frac{2}{85}\gamma}\right) \\
&\quad - \frac{6}{32}Q\left(19\sqrt{\frac{2}{85}\gamma}\right) - \frac{1}{32}Q\left(21\sqrt{\frac{2}{85}\gamma}\right) + \frac{2}{32}Q\left(23\sqrt{\frac{2}{85}\gamma}\right) \\
&\quad - \frac{3}{32}Q\left(25\sqrt{\frac{2}{85}\gamma}\right) - \frac{2}{32}Q\left(27\sqrt{\frac{2}{85}\gamma}\right) - \frac{1}{32}Q\left(29\sqrt{\frac{2}{85}\gamma}\right)
\end{aligned} \tag{6.25}$$

In (6.19), (6.20), (6.21), (6.22), (6.23), (6.24), and (6.25),  $\gamma$  is the SNR and  $Q(\dots)$  is the Q-function, which is defined as:

$$Q(x) = \frac{1}{\sqrt{2\pi}} \int_x^{\infty} \exp\left\{-\frac{x^2}{2}\right\} dx \quad (6.26)$$

**6.6.2. BER Expressions for Rayleigh Fading Channel.** The mathematical expressions for the BER performance of BPSK, 4-QAM, 16-QAM, and 64-QAM over a Rayleigh fading channel are given in [17] as:

$$P_{\text{BPSK}}(\gamma) = \frac{1}{2} \left( 1 - \sqrt{\frac{\gamma}{1 + \gamma}} \right) \quad (6.27)$$

$$P_{4\text{-QAM}}(\gamma) = \frac{1}{2} \left( 1 - \sqrt{\frac{\gamma}{2 + \gamma}} \right) \quad (6.28)$$

$$P_{16\text{-QAM}}(\gamma) = \frac{1}{4} \left[ \left( 1 - \sqrt{\frac{\gamma}{10 + \gamma}} \right) + \left( 1 - \sqrt{\frac{9\gamma}{10 + 9\gamma}} \right) \right] \quad (6.29)$$

$$\begin{aligned} P_{64\text{-QAM}}(\gamma) = & \frac{7}{24} \left( 1 - \sqrt{\frac{\gamma}{42 + \gamma}} \right) + \frac{1}{4} \left( 1 - \sqrt{\frac{9\gamma}{42 + 9\gamma}} \right) \\ & - \frac{1}{24} \left( 1 - \sqrt{\frac{25\gamma}{42 + 25\gamma}} \right) + \frac{1}{12} \left( 1 - \sqrt{\frac{81\gamma}{42 + 81\gamma}} \right) \\ & + \frac{1}{24} \left( 1 - \sqrt{\frac{121\gamma}{42 + 121\gamma}} \right) - \frac{1}{24} \left( 1 - \sqrt{\frac{169\gamma}{42 + 169\gamma}} \right) \end{aligned} \quad (6.30)$$

## 7. SIMULATIONS AND RESULTS

### 7.1. BER PERFORMANCE CURVES FOR AWGN CHANNEL

The BER performance curves for BPSK, QPSK, square 16-point QAM, and square 64-point QAM over an AWGN channel is shown in Figure 7.1. The BER plots were plotted using equations (6.19), (6.20), (6.21), and (6.22) for the range of SNR from 0dB to 30dB.

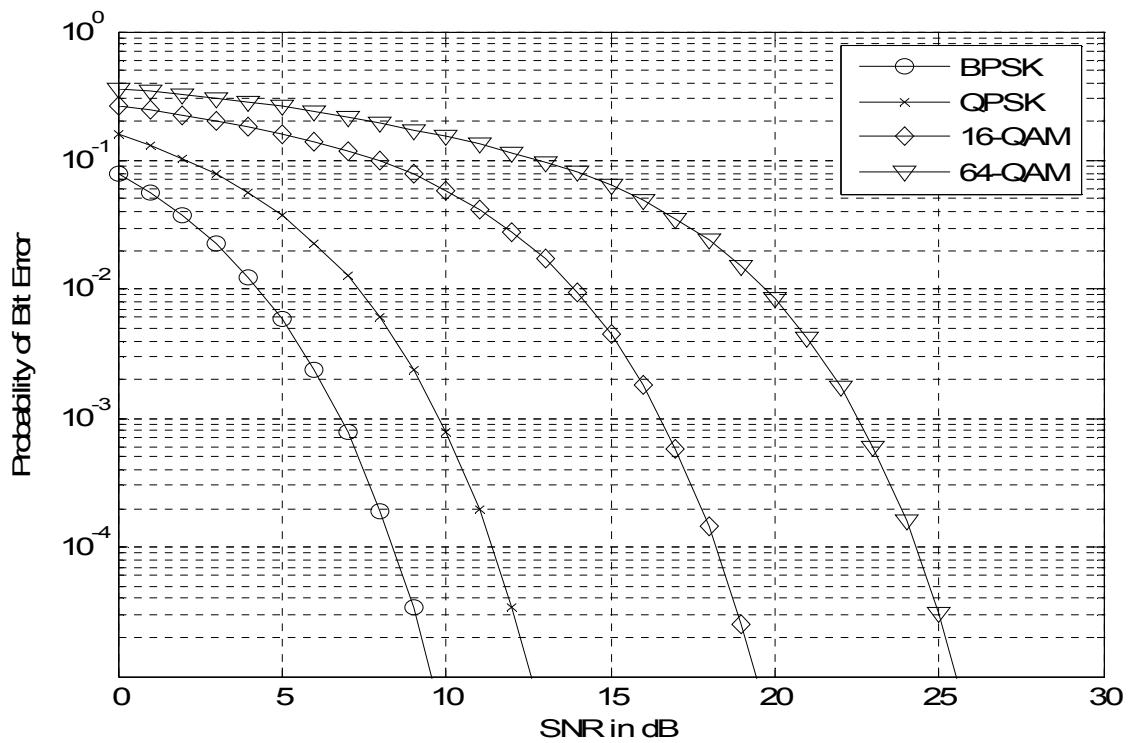

Figure 7.1. BER performance of BPSK, QPSK, square 16-QAM, and square 64-QAM in AWGN channel

The BER performance curves for 4-AM, 8-AM, and 16-AM over an AWGN channel is shown in Figure 7.2. The BER plots in Figure 7.2 were plotted over the SNR range of 0dB to 50 dB by using equations (6.23), (6.24), and (6.25), which were derived in [17] with Gray coding over an AWGN channel.

## 7.2. BER PERFORMANCE CURVES FOR RAYLEIGH FADING CHANNEL

The BER performance curves of BPSK, 4-QAM, 16-QAM, and 64-QAM derived from equations (6.27), (6.28), (6.29), and (6.30) over a flat Rayleigh fading channel is shown in Figure 7.3.

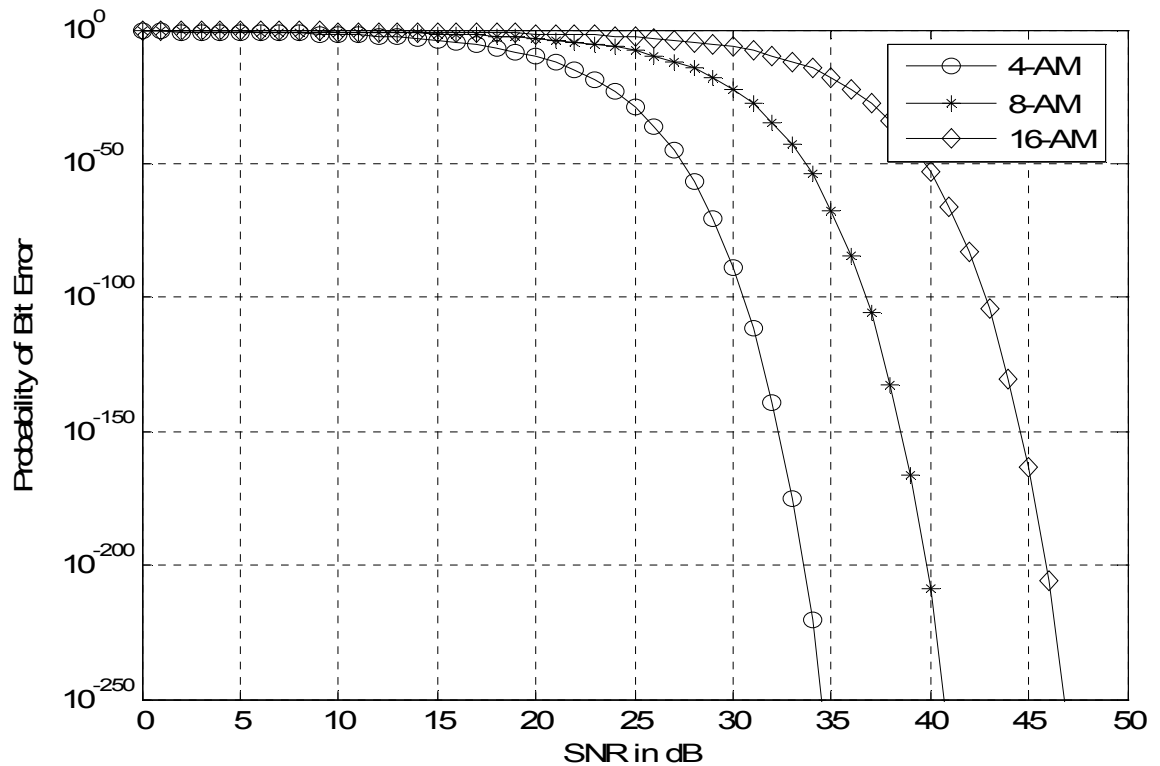

Figure 7.2. BER performance of 4-AM, 8-AM, and 16-AM in AWGN channel

### 7.3 OPTIMAL MODULATION FORMATS IN ADAPTIVE MODULATION

The optimal modulation formats in adaptive modulation for BPSK, QPSK, square 16-QAM, and square 64-QAM over an AWGN channel is shown in Figure 7.4. It has been assumed that the cognitive radio communication system under consideration needs the system BER to be below  $10^{-4}$ . From Figure 7.4, it can be inferred that, for a range of

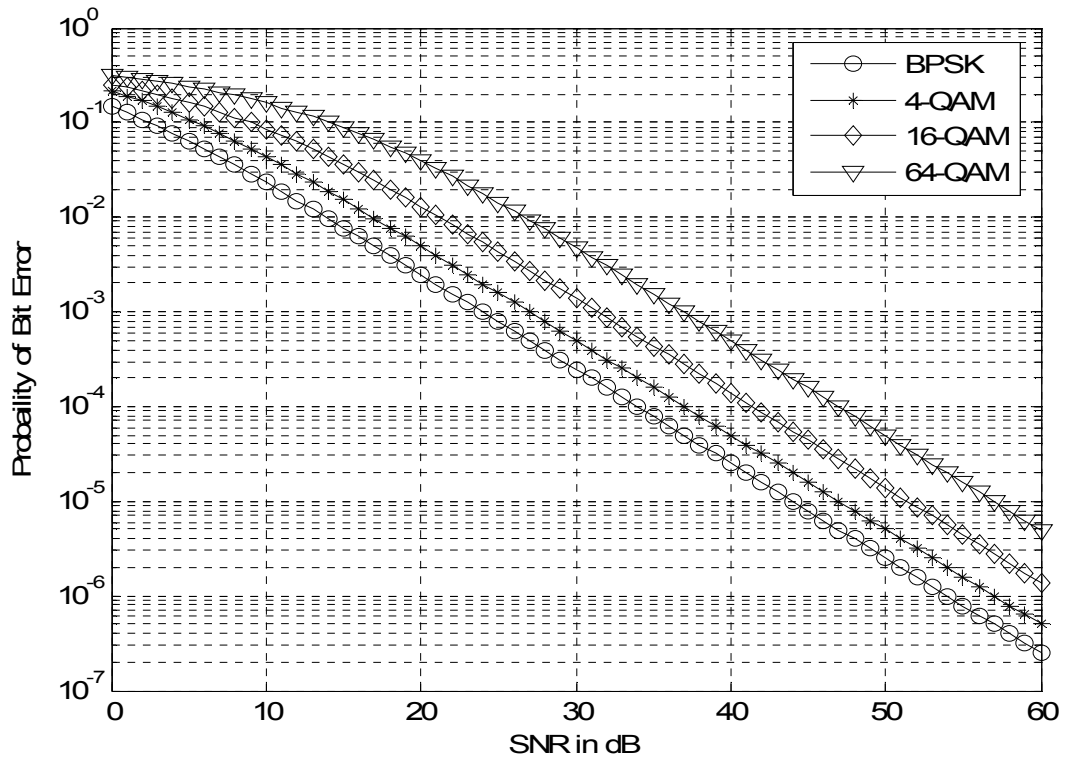

Figure 7.3. BER performance of BPSK, 4-QAM, 16-QAM, and 64-QAM in Rayleigh flat fading channel

SNR from 0dB to 30dB, the adaptive modulation based system constraints the BER below the required threshold of  $10^{-4}$ . For SNR from 8.5dB to 11dB, there are no

modulation schemes that give the desired BER performance but BPSK. So BPSK is chosen over all other available schemes. For SNR in the range  $11\text{dB} \leq \text{SNR} \leq 18\text{dB}$ , QPSK is chosen, as it gives a better BER performance than BPSK. Similarly, for the range of SNR from  $18\text{dB}$  to  $24\text{dB}$ , 16-QAM is chosen over QPSK, because it yields the desired BER performance at a higher spectral efficiency than QPSK. Likewise, 64-QAM is chosen over any other modulation schemes available from the group for values of SNR greater than  $24\text{dB}$ .

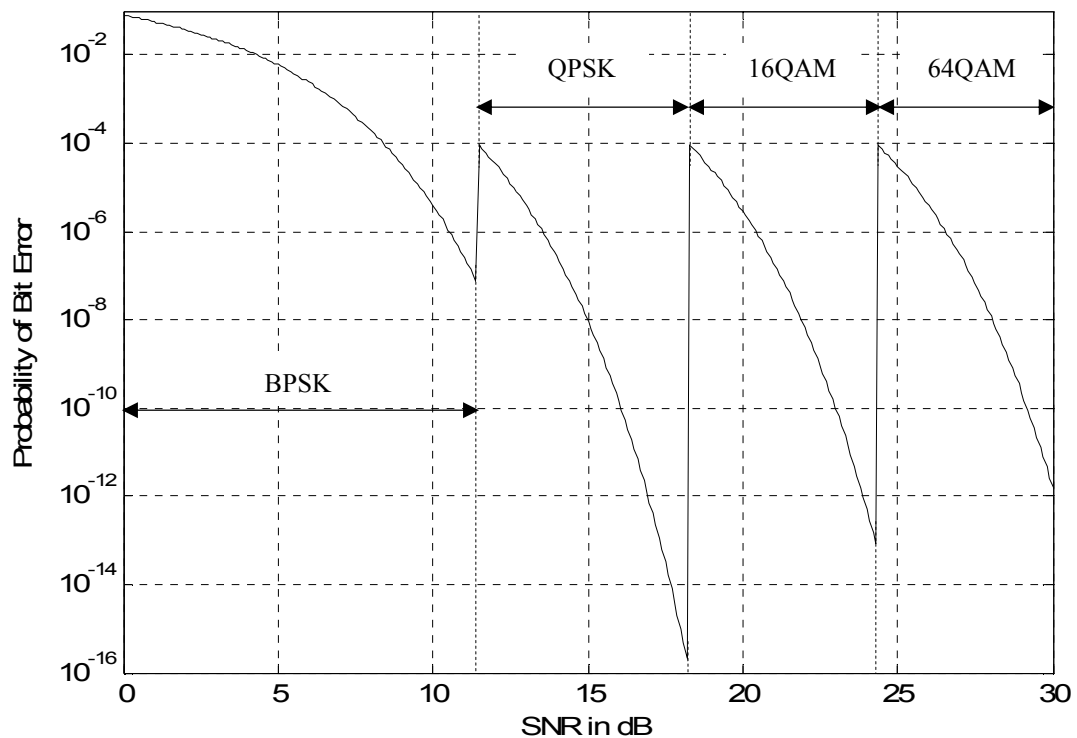

Figure 7.4. Optimal Modulation formats in Adaptive modulation for BPSK, QPSK, 16-QAM, and 64-QAM in AWGN channel



The optimal modulation formats in adaptive modulation for M-ary AM system for 4-AM, 8-AM, and 16-AM over an AWGN channel is shown in Figure 7.5. For values of SNR from 15dB to 21dB, the modulation scheme that yields the desired BER of  $10^{-4}$  is 4-AM. However, for  $21\text{dB} \leq \text{SNR} \leq 27\text{dB}$ , the modulation scheme that yields the desired BER at a better spectral efficiency than 4-AM is 8-AM. So 8-AM is chosen for  $21\text{dB} \leq \text{SNR} \leq 27\text{dB}$  range. Finally, for  $\text{SNR} \geq 27\text{dB}$ , 16-AM is chosen over 8-AM as it gives the desired BER performance at a spectral efficiency higher than that of 8-AM.

The optimal modulation formats in adaptive modulation for the modulation schemes, BPSK, 4-QAM, 16-QAM, and 64-QAM over a Rayleigh flat-fading channel is shown in the Figure 7.6. For the range of SNR from 33dB to 37dB, BPSK gives the desired BER performance of less than  $10^{-4}$ , so BPSK is chosen to be the operating modulation scheme. For a range of SNR from  $37\text{dB} \leq \text{SNR} \leq 41\text{dB}$ , 4-QAM is chosen over BPSK, because 4-QAM maintains the desired BER at a higher spectral efficiency than BPSK. Similarly, 16-QAM is chosen for  $41\text{dB} \leq \text{SNR} \leq 48\text{dB}$ , over 4-QAM for better system performance. Finally, for  $\text{SNR} \geq 48\text{dB}$ , 64-QAM is chosen over all other modulation formats available as it tops in spectral efficiency to all other modulation schemes maintaining the desired BER performance of  $10^{-4}$ .

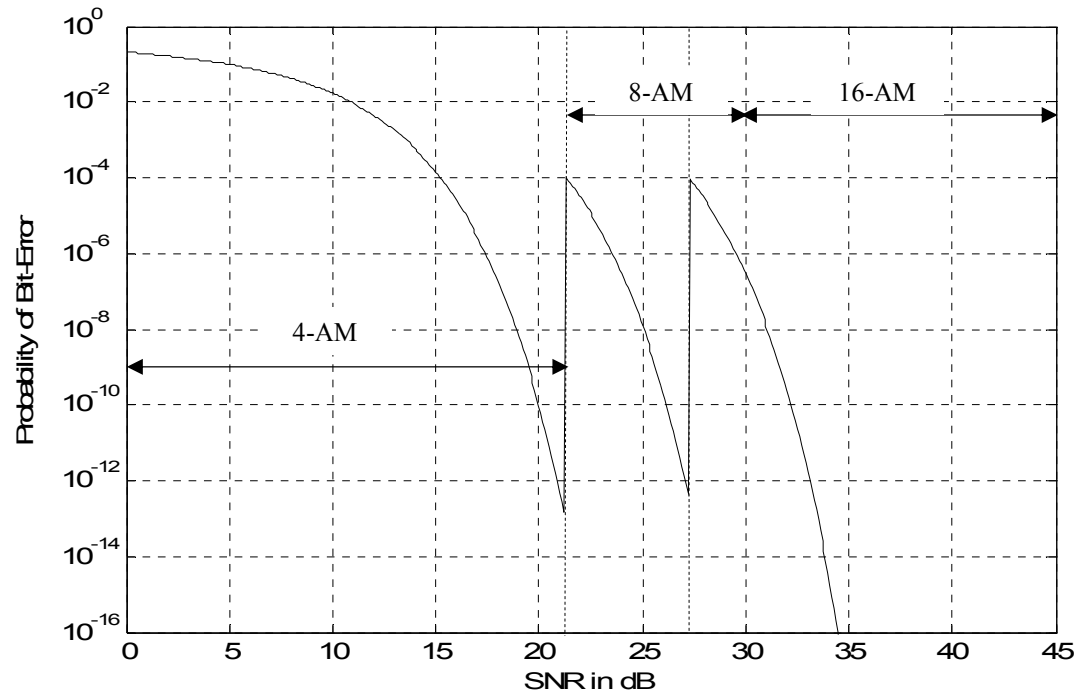

Figure 7.5. Modulation formats in adaptive modulation for 4-AM, 8-AM, and 16-AM in AWGN channel

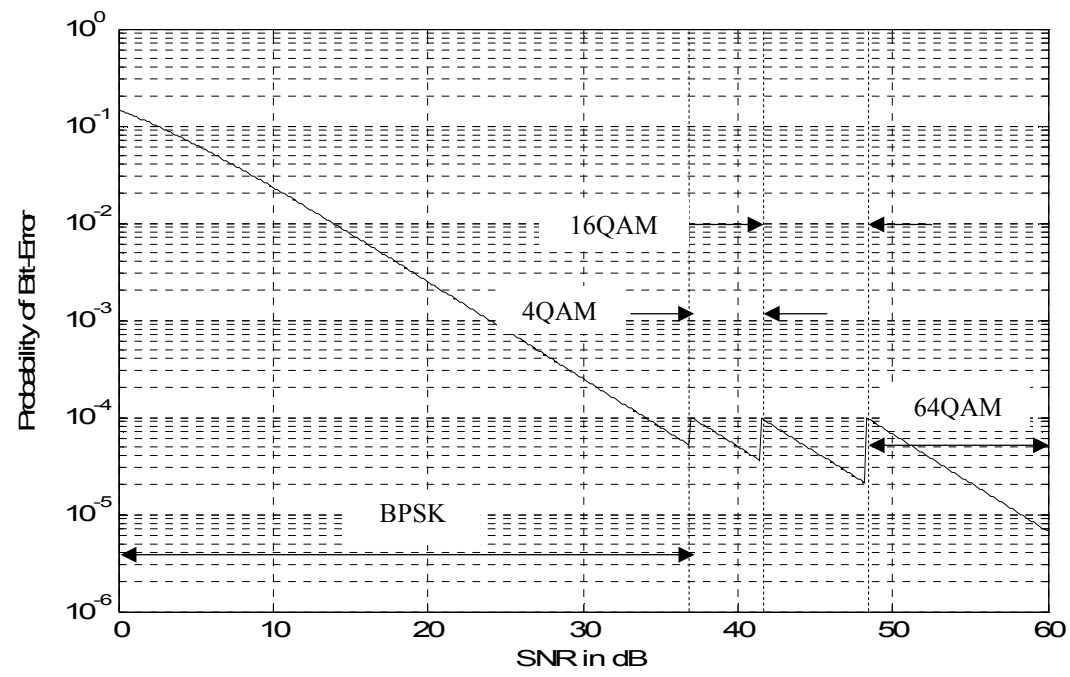

Figure 7.6. Optimal modulation formats in adaptive modulation for BPSK, 4-QAM, 16-QAM, and 64-QAM in flat fading Rayleigh channel

## 8. CONCLUSION

Cognitive radios have emerged to solve the current wireless communication system problems resulting from the limited available spectrum and the inefficiencies in the spectrum usage by exploiting the existing electromagnetic spectrum opportunistically. The ability of cognitive radios to quickly adjust in diverse wireless environments, make it an ultimate spectrum aware communication paradigm.

This thesis outlined a few concepts about how adaptive modulation can be incorporated in cognitive radio networks to improve the throughput of the system for dynamically varying channel conditions. Simulations show how changing modulation schemes by the transmitter depending on the SNR of the channel estimated at the receiver, helps wireless systems meet an average BER constraint. Rapid fluctuations of the channel with respect to time however, pose challenges to the appropriate functioning of the proposed adaptive modulation system. This makes the feedback channel state information the limiting factor in systems based on adaptive modulation.

## BIBLIOGRAPHY

- [1] FCC, "Spectrum Policy Task Force Report," *ET Docket* Vol. 02-155, Nov 2002.
- [2] G. Staple and K. Werbach, "The End of Spectrum Scarcity," *IEEE Spectrum* Vol. 41, No.3, pp 48-52, March 2004.
- [3] J. Mitola et al., "Cognitive radio: Making software radios more personal," *IEEE Personal Communications*, Vol. 6, No. 4, pp 13-18, August 1999.
- [4] J. Mitola, "Cognitive radio: An integrated agent architecture for software-defined radio," Doctor of Technology, Royal Institute of Technology, Stockholm, Sweden, 2000.
- [5] Simon Haykin, "Cognitive Radio: Brain-Empowered Wireless Communications," *IEEE journal on Selected Areas in Communications*, Vol. 23, No. 2, February 2005, pp 201-220.
- [6] Federal Communications Commission, "Spectrum Policy Task Force," ET Docket No. 03-108, March 11, 2005.
- [7] IEEE Draft Document, "Standard Definitions and Concepts for Spectrum Management and Advanced Radio System Technologies," June 2, 2006.
- [8] James Neel, Rekha Menon, Jeffrey H. Reed, and Allen B. MacKenzie, "Using Game Theory to Analyze Physical Layer Cognitive Radio Algorithms," Bradley Department of Electrical Engineering, Virginia Tech.
- [9] D. Cabric, Shridhar Mubaraq Mishra, Robert W. Brodersen, "Implementation Issues in Spectrum Sensing for Cognitive Radios," Berkeley Wireless Research Center, University of California, Berkeley.  
[http://bwrc.eecs.berkeley.edu/Publications/2004/PRESENTATIONS/dc.smm.asilomar/asilomar\\_paper\\_danijela.pdf](http://bwrc.eecs.berkeley.edu/Publications/2004/PRESENTATIONS/dc.smm.asilomar/asilomar_paper_danijela.pdf)
- [10] D. Cabric and R.W. Brodersen, "Physical layer design issues unique to cognitive radio systems," *IEEE Personal Indoor and Mobile Radio Communications (PIMRC) 2005*, Sept. 2005.
- [11] H. Tang, "Some Physical layer issues of wide-band cognitive radio system," *Proceedings, IEEE DySPAN 2005*, November 2005, pp. 151-159.
- [12] T.A. Weiss, F.K. Jondral, "Spectrum Pooling: an innovative strategy for the enhancement of spectrum efficiency," *IEEE Radio Communication Magazine* 42, March 2004, pp. 8-14.

- [13] Hongqiang Zhai and Yuguang Fang, "A Solution to the Hidden Terminal Problem over a Single Channel in Wireless Ad Hoc Networks," Department of Electrical & Computer Engineering, University of Florida, Gainesville, Florida.  
<http://www.ecel.ufl.edu/~zhai/publication/milcom06zhai.pdf>
- [14] Theodore Rappaport, "*Wireless Communications- Principles and Practice*," Prentice Hall, 2<sup>nd</sup> Edition, 2002, Upper Saddle River, New Jersey.
- [15] Simon Haykin, "*Digital Communications*." John Wiley and Sons, 2003, Singapore.
- [16] L. Hanzo, S.X. NG, T. Keller and, W. Webb, "*Quadrature Amplitude Modulation, From Basics to Adaptive Trellis-Coded, Turbo-Equalized and Space-Time Coded OFDM, CDMA and MC-CDMA Systems*," Second Edition, Wiley, [wiley.com](http://wiley.com), IEEE, IEEE Press, pg 677-681, 2004, West Sussex, England.
- [17] Mohamed-Slim Alouni, Xiaoyi Tang, and Andrea J. Goldsmith, "An Adaptive Modulation Scheme for Simultaneous Voice and Data Transmission over Fading Channels," *From IEEE Journals on Selected Areas in Communications*, Vol. 17, No. 5, May 1999.
- [18] Sorour Falahati, Arne Svensson "Adaptive Modulation Systems for Predicted Wireless Channels," *From IEEE Transactions on Communications*, Vol. 52, No. 2, Feb. 2004.
- [19] J.M. Torrence, L. Hanzo, "Upper bound performance of adaptive modulation in a slow Rayleigh fading channel," *IEEE Electronics Letters*, 11<sup>th</sup> April 1996, Vol. 32, No. 8, pg 718.

## VITA

Gaurav Sharma was born and raised in Kathmandu, Nepal, on January 8<sup>th</sup>, 1982. He received his Bachelor's degree in Electronics and Communication Engineering from the Institute of Engineering, Tribhuvan University, Nepal, in 2004. He worked as a System Network Engineer in Square Network Private Limited, Lalitpur, from December 2004 through December 2005. He then came to the United States to pursue a Master of Science degree in Electrical Engineering at the University of Missouri – Rolla in January 2006. His topics of interests include wireless communications and signal processing with specialization in Cognitive Radios. Gaurav Sharma received his Master of Science in Electrical Engineering degree in May 2008.