

---

Masters Theses

Student Theses and Dissertations

---

Fall 2010

## Internet-accessible hot cell with gamma spectroscopy at the Missouri University of Science and Technology research nuclear reactor

Edwin Grant

Follow this and additional works at: [https://scholarsmine.mst.edu/masters\\_theses](https://scholarsmine.mst.edu/masters_theses)



Part of the [Nuclear Engineering Commons](#)

Department:

---

### Recommended Citation

Grant, Edwin, "Internet-accessible hot cell with gamma spectroscopy at the Missouri University of Science and Technology research nuclear reactor" (2010). *Masters Theses*. 6731.

[https://scholarsmine.mst.edu/masters\\_theses/6731](https://scholarsmine.mst.edu/masters_theses/6731)

This thesis is brought to you by Scholars' Mine, a service of the Missouri S&T Library and Learning Resources. This work is protected by U. S. Copyright Law. Unauthorized use including reproduction for redistribution requires the permission of the copyright holder. For more information, please contact [scholarsmine@mst.edu](mailto:scholarsmine@mst.edu).



INTERNET-ACCESSIBLE HOT CELL  
WITH GAMMA SPECTROSCOPY AT THE  
MISSOURI UNIVERSITY OF SCIENCE AND TECHNOLOGY  
RESEARCH NUCLEAR REACTOR

by

EDWIN JOSEPH GRANT

A THESIS

Presented to the Faculty of the Graduate School of the

MISSOURI UNIVERSITY OF SCIENCE AND TECHNOLOGY

In Partial Fulfillment of the Requirements of the Degree

MASTER OF SCIENCE IN NUCLEAR ENGINEERING

2010

Approved by

Gary E. Mueller, Advisor

Arvind Kumar

Shoaib Usman

Carlos H. Castaño



## **PUBLICATION THESIS OPTION**

This thesis consists of the journal article that will be submitted for publication to Nuclear Engineering & Design Journal. Pages 1-25 of this thesis have been prepared in the style utilized by the Nuclear Engineering & Design Journal.

## ABSTRACT

A dual-chambered internet-accessible heavily shielded facility with pneumatic access to the University of Missouri Science and Technology (Missouri S&T) 200 kW Research Nuclear Reactor (MSTR) core has been built and is currently under low level irradiation testing. The facility allows distance users doing collaborative work with Missouri S&T researchers to manipulate and analyze neutron irradiated samples remotely. The system consists of two shielded compartments, one for multiple sample storage (up to 11 samples), and the other for isolated radiation measurements and spectroscopy. The second chamber has multiple detector ports, graded shielding, and has the capability to support gamma spectroscopy using a multitude of radiation detectors such as an HPGe detector. Both these chambers are connected through a rapid pneumatic system (rabbit) with access to the MSTR reactor. This new internet-based system will complement the current bare rabbit tube (BRT) and cadmium lined rabbit tube (CRT) facilities. The total transportation time between the core and the hot cell, for samples weighing approximately ten grams is roughly 3.0 seconds. This work was funded by the DOE grant number DE-FG07-07ID14852 and will expand the capabilities of research at the MSTR, and allows others to actively participate in research.

## ACKNOWLEDGEMENTS

I would like to extend heartfelt gratitude and deep appreciation to Dr. Gary E. Mueller, my advisor, whose guidance and direction immensely helped me through both my Bachelor's and Master's Degree.

I would also like to thank my committee members, Dr. Shoaib Usman, for his expertise with his radiation detection and measurement, Dr. Carlos Castaño for his insight for possible problems further down the road, and Dr. Arvind Kumar for his motivation and long discussions on the hot cell which ultimately produced an enhanced hot cell design. I would also like to thank the Nuclear Engineering Program for financial support during the design, construction, and testing phases of the hot cell facility. In addition to the Nuclear Engineering Program, I would like to thank Sheila Johnson for helping me through paperwork and the business side of academic.

I want to deeply thank the staff of the Missouri S&T research nuclear reactor especially Mr. William Bonzer, the Reactor Manager, and Craig Reisner, the Reactor Senior Mechanic, for setting aside copious amounts of time to help design, machine custom parts, constructing, and finishing the hot cell facility around the MSTR.

Most importantly, I would like to thank my family who allowed me to achieve things that were not possible for them and Pamela Roach who helped me through this journey day in and day out, through good or bad days; without them none of this would have been possible.

## TABLE OF CONTENTS

	Page
PUBLICATION THESIS OPTION.....	iii
ABSTRACT.....	iv
ACKNOWLEDGEMENTS.....	v
LIST OF ILLUSTRATIONS.....	vii
LIST OF TABLES.....	viii
<b>PAPER</b>	
1. Internet Accessible Hot Cell with Gamma Spectroscopy at the Missouri S&T Nuclear Reactor.....	1
Abstract.....	1
1. Introduction.....	2
2. Design Requirements.....	2
2.1. Pneumatic Transportation System.....	3
2.2. Radioactive Sample Manipulation System.....	4
2.3. Radiation Measurement and Spectroscopy System.....	4
3. Design Implementation.....	4
3.1. Pneumatic Transportation System.....	6
3.2. Radioactive Sample Manipulation System.....	9
3.3. Radiation Measurement and Spectroscopy System.....	12
4. MCNP Model.....	15
5. MCNP Results.....	17
6. HCRT Technical Specification.....	21
7. Conclusion.....	22
REFERENCES.....	24
<b>APPENDICIES</b>	
A. MCNP INPUT FILE.....	26
B. LIST OF MAJOR COMPONENTS.....	42
VITA.....	44



**LIST OF ILLUSTRATIONS**

	Page
Fig. 1. Exploded View of Custom Built G-16-S .....	6
Fig. 2. Pneumatic Transport System Mapped Out .....	7
Fig. 3. In-Core Assembly Design .....	8
Fig. 4. Heat Treatment of In-Core Assembly .....	8
Fig. 5. MSTR Core Configuration 120 Mode W .....	9
Fig. 6. Pneumatic Flow Safeguard Control .....	10
Fig. 7. Wiring Schematic for PLC Electronics .....	11
Fig. 8. Online Gamma Spectroscopy .....	13
Fig. 9. Hot Cell System with HPGe Detector .....	14
Fig. 10. MCNP Geometric Model .....	15
Fig. 11. Modeled Sample Revolver and Step Motor Assembly .....	16
Fig. 12. X-Y Axis Dose Rate Plot of Counter Cell with 2.5 MeV Gamma Source.....	17
Fig. 13. Counter Cell Dose Rate Location Identification .....	19
Fig. 14. Maximum Activity Around the Detection Shield .....	20
Fig. 15. Maximum Activity for 100 mrem/hr Dose Rate on Counter Surface .....	21

**LIST OF TABLES**

	Page
Table 1. Maximum Activity mCi with 100 mrem/hr at Shield Wall.....	18
Table 2. HCRT Technical Specifications.....	22

# **Internet Accessible Hot Cell with Gamma Spectroscopy at the Missouri S&T Nuclear Reactor**

Edwin J. Grant, Gary E. Mueller<sup>1</sup>, Carlos H. Castaño, Shoaib Usman, Arvind Kumar

Nuclear Engineering, Missouri University of Science and Technology, 203 Fulton Hall, 300W.  
13th St., Rolla, MO-65409, United States

## **Abstract**

A dual-chambered internet-accessible heavily shielded facility with pneumatic access to the University of Missouri Science and Technology (Missouri S&T) 200 kW Research Nuclear Reactor (MSTR) core has been built and is currently under low level irradiation testing. The facility allows distance users doing collaborative work with Missouri S&T researchers to manipulate and analyze neutron irradiated samples remotely. The system consists of two shielded compartments, one for multiple sample storage (up to 11 samples), and the other for isolated radiation measurements and spectroscopy. The second chamber has multiple detector ports, graded shielding, and has the capability to support gamma spectroscopy using a multitude of radiation detectors such as an HPGe detector. Both these chambers are connected though a rapid pneumatic system (rabbit) with access to the MSTR reactor. This new internet-accessible system will complement the current bare rabbit tube (BRT) and cadmium lined rabbit tube (CRT) facilities. The total transportation time between the core and the hot cell, for samples weighing approximately ten grams is roughly 3.0 seconds. This work was funded by the DOE grant number DE-FG07-07ID14852 and will expand the capabilities of research at the MSTR, and allows others to actively participate in research.

**Key Words:** Hot cell, Internet-accessible, Neutron irradiation, MCNP, Shielding

---

<sup>1</sup> Corresponding Author. Tel.: +1 573 341 4348; fax: +1 573 341 6309.  
E-mail address: [gmueller@mst.edu](mailto:gmueller@mst.edu) (G. Mueller).

## **1. Introduction**

The Missouri S&T Reactor (MSTR) is a pool type research nuclear reactor that first went critical in December 1961 with a maximum operational power of 10 kW, detailed by license R-79 (Bonzer 2010). Later, in 1967, the MSTR was upgraded to a current maximum operational power of 200 kW. As a part of the Reduced Enrichment for Research and Test Reactors (RERTR) program the original highly enriched uranium (HEU) fuel was replaced with 20 percent low enriched uranium-235 (LEU) fuel in July 1992 (Matos 1996). The reactor's chain reaction is controlled via 4 stainless steel control rods. Three shim rods allow for coarse reactivity control and the single regulating rod allows for fine reactivity control. Each of the shim rods contain 1.5% by weight of natural boron, while the regulating rod (control rod 4) contains zero boron and is made of pure stainless steel 304 (Bonzer and Carrol 2009). The reactor was originally built with both a beam port and a thermal column facility, and in order to increase the number of research facilities a bare and cadmium lined rabbit system were added through the years. Before the hot cell rabbit (HCRT) system was built, researchers either had to be physically present at the MSTR to do their experiments or face the time consuming and laborious process of having their samples sent in and their results shipped back. Now thanks to the HCRT users can remotely access their samples in real time, and manipulate their samples in front of radiation detection equipment and save their spectral data from their own desks anywhere in the world. This internet-accessible hot cell is a unique, one-of-a-kind design available only at MSTR and it has the ability to control post-irradiated experiments with data collection from across the globe via the internet.

## **2. Design Requirements**

Before building the hot cell system a rigorous pre-design analysis was performed in order to ensure that it would incorporate selected key ideas. The analysis also allowed for careful consideration and selection of components robust enough to support the needs for the project. First, the proposed system needed to utilize and accommodate multiple samples, in contrast with the current rabbit system, which can only use one sample with no storage capacity. Having the ability to place multiple samples in predetermined storage locations allows highly active short-lived isotopes to safely decay away without human intervention; therefore unmasking any long lived isotopes.

Within the detection chamber there must be multiple detection ports of different sizes for different types of radiation detectors to be used. Each chamber not only needs to properly shield the reactor staff, students, and public but also needs to shield samples from external sources, including background radiation. The key advantage of having two separate chambers allows for isolating one sample's spectrum from the rest of the samples within the storage cell. Another important idea within the detection chamber is to incorporate graded shielding to remove low energy K shell  $\alpha$  and  $\beta$  X-rays from the shield itself which could degrade the samples spectrum (Wolbarst 2005). The overall hot cell system consists of the following key components:

1. Pneumatic transportation system
2. Radioactive sample manipulation system
3. Radiation detection and spectroscopy system

The pneumatic transport system, radioactive sample manipulation system, and radiation detection with spectroscopy system must all be fully integrated into an automatic remotely accessible internet-based computer system.

### *2.1 Pneumatic Transportation System*

The medium used to transport samples must exhibit low neutron activation properties to minimize the concern of contaminated gas. Containers holding the specimens must also exhibit low neutron activation properties. If the specimen vial were to become activated during irradiation it would affect later spectroscopic measurements. Also, the size of the container must be large enough to fit adequate size samples while being air tight. The transit time, of the sample, from the core back to the hot cell must be small. A small transit time helps minimize the dose to the public and the reactor staff. The pneumatic system must be able to move samples with a minimum mass of 5 grams. To safely exhaust pneumatic gas the system must incorporate high efficiency particulate air (HEPA) filters. To prevent gases from escaping near the core a custom in-core assembly will be needed. Furthermore, the custom in-core assembly needs to be flexible to allow for multiple core locations for future changes to the core configurations

### *2.2 Radioactive sample manipulation system*

In order to make the sample manipulation system robust several levels of automation are needed. The hardware selected for the system should preferentially be

standard equipment which has been used is engineering practice allowing for easy upgrades and replacements, as needed. The automation process must be able to incorporate both pneumatic transfer of the sample and manipulating multiple samples to select a single user sample. Also the automation must be able to link directly with a computer and have a graphical user interface that someone can control remotely. The manipulation system must also be able to consistently reproduce experiments without need for human intervention. All of the manipulation equipment must also be within the sealed pneumatic transportation system to prevent escape of activated gasses. Some type of containment structure will be needed to conform around the manipulation equipment to properly seal and hold pneumatic gases once the gas has traveled through the core.

### *2.3 Radiation Measurement and Spectroscopy System*

The design of the radiation measurement and spectroscopy system was one of the toughest parts of the design because a system that incorporates internet-accessible radiation spectroscopy with sample automation is not common. The spectroscopy system will need to allow for multitude of different options for users at the MSTR or using the internet option. Some of the options needed are gain control, upper and lower discrimination, and bias voltage, as well as radiation counting/collection time. One major goal is that the system allows for multiple users can watch and record live data at the same time. Another aspect of the spectroscopy system is detector geometry and orientation design. The design should allow for multiple types of detectors, of different sizes, and allow for unique detection techniques such as coincidence measurement.

### **3. Design Implementation**

Once the guidelines of the design were identified it was possible to research different materials and equipment.

First, the shield itself was an important design parameter that was fulfilled with the Roll Top Counting Shield from Gamma Products, Inc. was selected as the best overall design. As a counting shield, the standard G-16-S incorporates no options for detector ports; however Gamma Products has the capability to add multiple ports.

A top rail mount design was convenient for the benefit of easy inspection of key mechanical and pneumatic devices which will be placed within the cell. Other possible

designs were based on sliding doors that locked together. Those designs were not selected due to the convenience and availability of the shields by Gamma Products Inc.

Two shielded cells were selected, one for storage and one for spectroscopy. The basement of the reactor was selected for the HCRT shielded cells to help provide distance between irradiated samples and the reactor bay. With each shield weighing, in excess of, 2900 pounds transportation into the MSTR basement mandated the cells required the ability to be dismantled (Gamma Products, Inc. 2009). The custom G-16-S cells were designed to have the capability to be disassembled and reassembled. Also, the ability to be disassembled allows for possible future modifications. Gamma Products offer both a lead and an A36 steel option for shielding material. The A36 steel option was selected due to the fact that lead has the potential concern of toxicity during future machining on campus. In fact, at the time of purchase the cost for the lead model, with machining and manufacturing, was roughly twice as expensive as the steel option. Figure 1 indicates how each cell is fully constructed with the detailed layout of detector port locations.

The design allows for up to three three High Purity Germanium (HPGe) detectors located in the center of parts 2, 4, and 7, as seen in Figure 1. The HPGe port geometry allows for many experiments including coincidence testing with surface 2 and 4. Four other smaller one inch diameter ports are located on part 7 to allow cabling into the shield for mechanical manipulation. The smaller ports surround the HPGe port in a square formation. When in use, the smaller ports are positioned where lead blocks can be placed within the shield for shielding the open ports. In addition to cabling, the smaller ports are positioned to be used for Geiger-Müller tubes. Geiger-Müller tubes will be used to verify count rates inside the shield. Installed video monitoring equipment within the nuclear reactor facility can visually verify count rates from portable ion chambers and along with dose rates if the spectroscopy system should fail. Parts 1 and 3 provide space for the pneumatic transfer piping entering and leaving the shield. Stainless steel 316 sleeves were machined to fit between the pneumatic ports and the smaller pneumatic tubes. The 3 inch diameter pneumatic port holes allow for different sized pneumatic tubes in case of future additions.

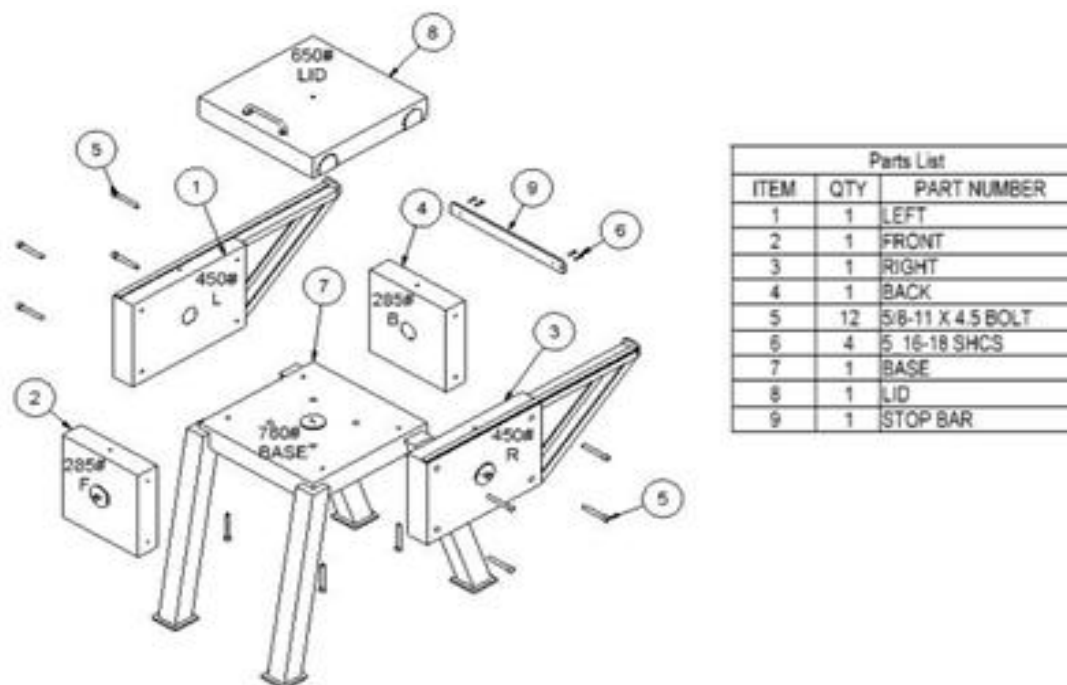
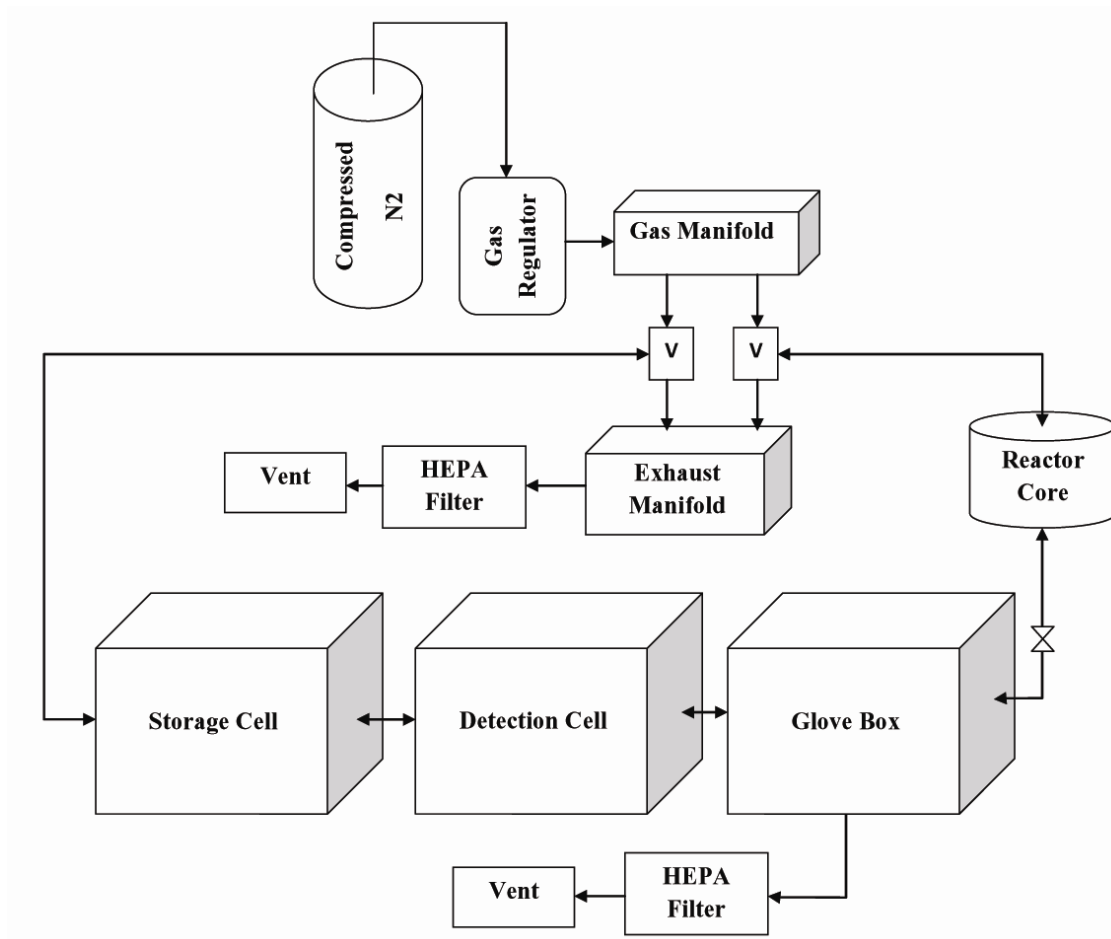

**Fig. 1.** Exploded View of Custom Built G-16-S Shield

### *3.1 Pneumatic Transportation System*

Nitrogen was selected as the medium for the transportation system due to concerns about neutron activation in generic compressed air. Figure 2 details the transportation of samples throughout the pneumatic system. Sealable low density polyethylene vials are used to contain the specimens during transportation because they exhibit low activation after typical sample irradiations. The physical dimensions of the vials are 7/8" OD by 2-1/4" overall height, leading to a total volume of 16.9 ml (Cole-Parmer 2010). The physical dimensions are ample enough to hold many different sized specimens with a mass of 5 grams. To guarantee proper transit, in the HCRT, a maximum sample mass with vial is set to approximately 16.9 grams. The total transit time from the reactor core to the inside of the shield cells is approximately 3 seconds. During the 3 seconds the sample travels through 85 feet of pneumatic tubing with an average velocity of 28 ft/s. This high speed allows for any external dose to be limited during sample transportation.





**Fig. 2.** Pneumatic Transport System Mapped Out

Aluminum 6061 was chosen as the in-core material due to its lower neutron absorption cross section as compared to other steel alloys (Baum et al. 2002). Aluminum 6061 has been used in a wide variety of designs for low temperature research reactors and has proven performance record for the past 50 years (Farrell 2001). Figure 3 shows the design of the in-core assembly which directs the pneumatic flow, to or from the core, depending on which direction the sample needs to be moved. This in-core assembly was completely designed, constructed, heat treated, and pressure tested in-house. The in-core assembly was designed to allow the centerline of the sample vial to stop at the midpoint of the reactor fuel assemblies to maximize the neutron flux irradiation.

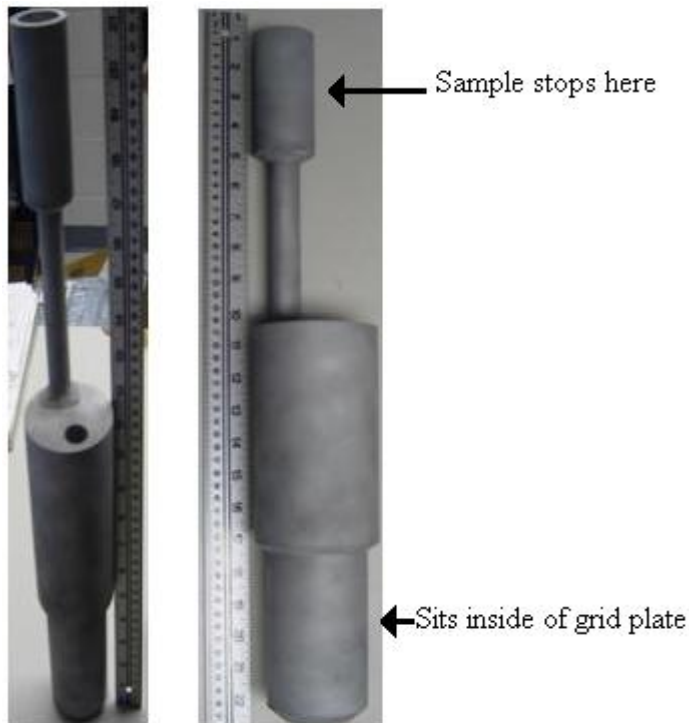

**Fig. 3.** In-Core Assembly Design

After welding all of the pieces together to form the in-core assembly the aluminum was heat treated to regain the finely dispersed  $Mg_2Si$  precipitate around the heat affected zones of the welds (Bizub 2010). Another reason for heat treating the aluminum is to minimize hair line cracks propagating from high neutron fluences regions. The lower six feet of the in-core assembly, where all of the welds are located, was heated to  $350^\circ F$  for 8 hours, as seen in Figure 4. The heat treatment allowed the 6061 aluminum to regain most of its temper around the entire heat affected zones while not softening the base material neighboring the weld sites.



**Fig. 4.** Heat Treatment of In-Core Assembly

The position of the HCRT within the fuel grid plate is location F6 as shown in Figure 5. The position of the HCRT can change with different core configurations. The design of the in-core assembly was purposely adjusted to allow for proper clearances if the unit needs to be moved. In fact, the in-core assembly design has already proved its flexibility when the core was changed from 101 W to the current 120 W mode in the summer of 2010.

Grid Position	1	2	3	4	5	6	7	8	9
A									
B						Source			
C					Control rod 4	Fuel 5	Fuel 1	Fuel 17	
D				Fuel 4	Fuel 8	Fuel 14	Control rod 1	Fuel 10	Fuel 2
E				Fuel 9	Control rod 3	Fuel 12	Control rod 2	Fuel 7	Fuel 3
F	CRT				Fuel 15	HCRT	Fuel 13	BRT	Fuel 6

**Fig. 5.** MSTR Core Configuration 120 Mode W

### 3.2 Radioactive Sample Manipulation System

A Programmable Logic Controller (PLC) was selected to control the sample manipulation system in the storage cell. This component is essential to make multiple processes and control them in a precise sequence. The selected system is a DPY 50601 from Anaheim Automation Inc. which allows for eight inputs, eight outputs, and one single axis step motor for control (Anaheim Automation, Inc. 2005). Each input and output has time resolution control of one millisecond allowing ultra fine control of the system. The PLC is controlled by a PC via a RS-232 to RS-485 converter which was used to increase the maximum distance between the PLC and PC from 25 feet to 4000 feet. The distance between the two units allows the controlling computer to sit inside the

MSTR control room which is approximately 200 feet. Also the PLC has a built-in stepping motor indexer which allows up to 12800 steps per revolution or a rotational resolution of 0.028125 degrees per step which allows for fine control.

A stepping motor setup was included as a component of the radioactive sample manipulation system in order to help transfer different samples. The model 8718L stepping motor from Lin Engineering was selected because of its high torque, accuracy, and resolution (Lin Engineering 2010). The stepping motor receives control signals from the PLC and rotates the storage revolver until the chosen sample is loaded. This operates a similar way a revolver loads a bullet into the chamber. This expands the system so that it is able to handle more than a single sample and in the current configuration allows for up to eleven different research samples to be active during any given time. There are twelve different slots in the revolver but the first position has been designated as an open position and the zero reference point for the PLC. By keeping the first slot open there is no streaming through the pipe during storage. A small aluminum 6061 containment structure was constructed around the revolver to contain all radioactive material. Aluminum 6061 was selected as the material for the revolver and containment building material due to its high strength, low cost, excellent corrosion resistance, and low neutron activation cross section, which are all beneficial for long term use. The containment box also allows the compressed pneumatic gases to easily transport samples without any major loss of gas pressure that could hinder sample transportation into the core.

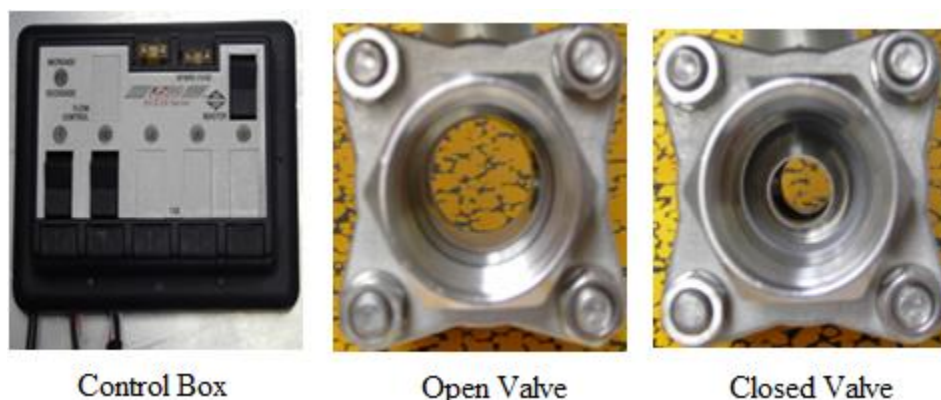

**Fig.6.** Pneumatic Flow Safeguard Control. To the Left: PLC 8718L from Lin Engineering. Center and Right: Open and close servo actuated ball valves. When the valve is closed the sample is stopped but compressed nitrogen still is allowed to pass.

To stop a given sample directly in front of the HPGe detector for spectroscopy two electrically actuated ball valves were added in series to limit available pneumatic transport. Both of the ball valves are installed within the spectroscopy shielded cell, and depending upon which direction the sample is coming one ball valve is closed to stop the sample. Figure 6 shows how the ball valve limits transportation of samples. In order to guarantee exhaust gasses are released towards the exhaust manifold holes were drilled perpendicular into the ball valve. The drilled holes were bored to let gasses escape but small enough to stop a sample without breaking it.

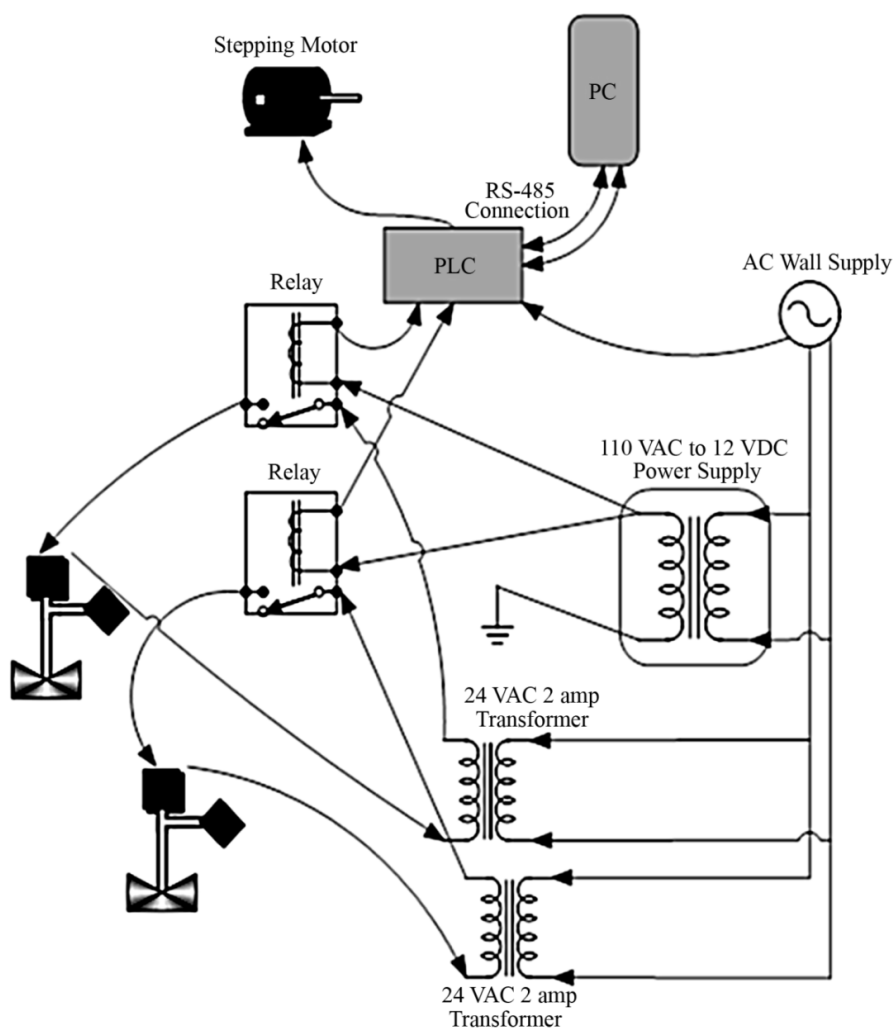

**Fig. 7.** Wiring Schematic for PLC Electronics

The valves also inherently give the nuclear reactor facility staff the ability to stop any sample from being transported without consent. Manual operation of the ball valves is controlled by a rocker switch panel within the nuclear reactor facility. Physical onsite control gives the ability to stop any rogue online user from misusing the hot cell facility.

In order to control the pneumatic valves relay coils, transformers, and power supplies were added to make the needed voltages compatible. Figure 7 details the wiring scheme needed to correctly integrate all electronic components to the PLC. The PLC can only allow connections with 12 VDC components, which are widely used in industry, so an intermediate 12 VDC relay was connected between the pneumatic valve and the PLC. In order to power the pneumatic valve a step down transformer was used to convert the 110 VAC wall supply down to the required 24 VAC.

### *3.3 Radiation Measurement and Spectroscopy System*

A direct online server system is needed to allow an internet-based option for collecting spectroscopy data. The Canberra Lynx system was selected and it connects directly to an internet connection and has its own unique web address ([www.rad-lynx2.device.mst.edu](http://www.rad-lynx2.device.mst.edu)) so that users can locate it with an internet browser, as seen in Figure 8.

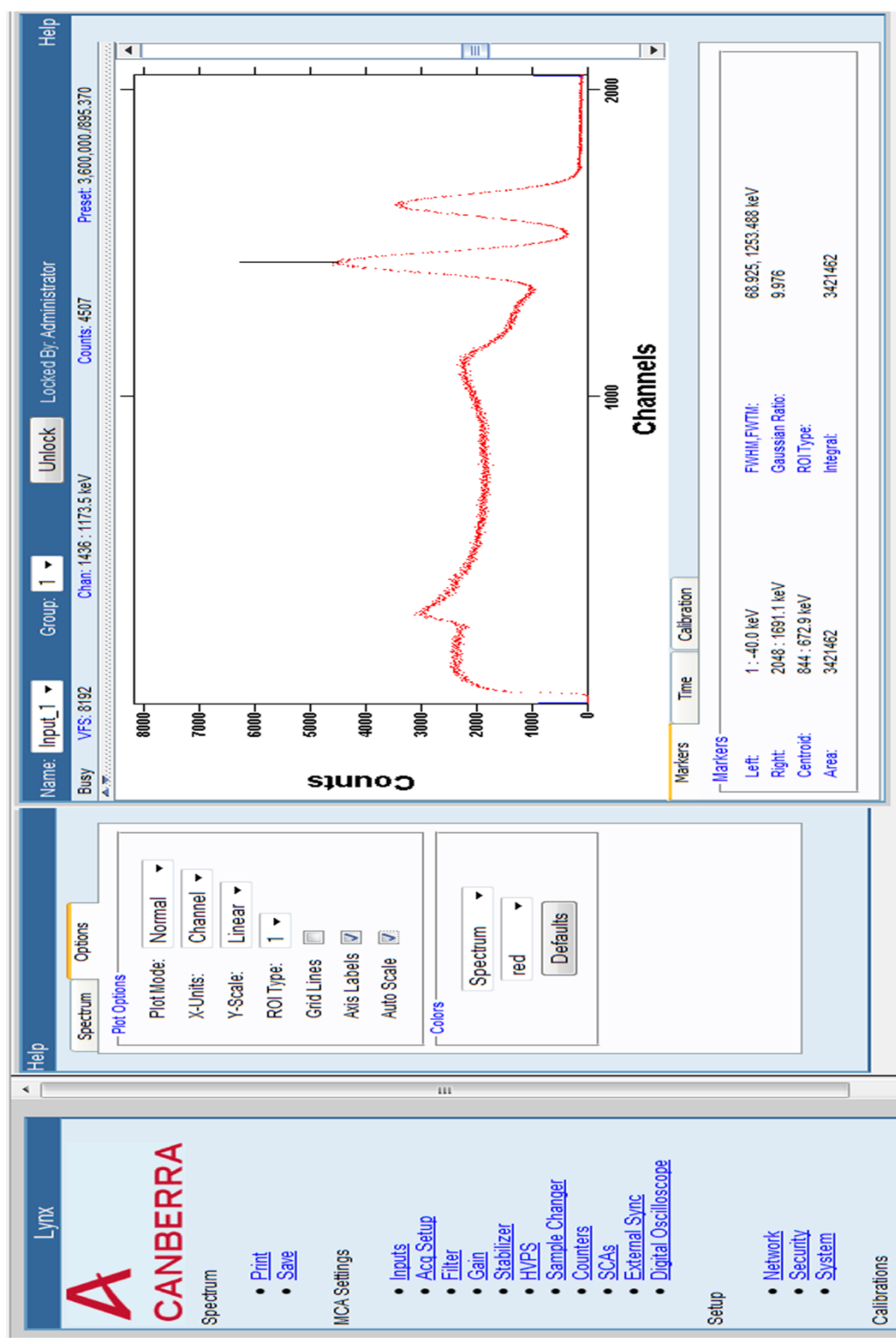

Fig. 8. Online Gamma Spectroscopy

A brief introduction and tutorial for becoming familiar with using the internet facility is available for new users<sup>2</sup>. In order for a user to control the system they must use a virtual network connection (VNC) to be granted access to the secure Lynx server. A username and password will be sent to the user for access to manipulate the specimen and collect the spectrum of data. Users are able to acquire data directly from the HPGe detector within the shielded cell. The Lynx system allows of other detectors including NaI(Tl) and Lanthanum Halide. Standard spectrum and instrument manipulation techniques are also available to users, such as selecting regions of interest, changing rough and fine gain control, multichannel analyzer (MCA), multichannel scalar (MCS), single channel analyzer (SCA), energy calibration, high voltage power supply (HVPS) change and saving collected data. Additionally, the system has three levels of security: VNC with optional IP address verification; two locally controlled, normally closed shutoff valves; and one, locked sample stop valve to guarantee cyber security and stop unauthorized core access.



**Fig. 9.** Hot Cell System with HPGe Detector

---

<sup>2</sup> Inquires about experimental research along with HCRT tutorials can be made by sending a request to Dr. Gary Mueller at +15733414348 or gmueller@mst.edu



To perform gamma spectrometry the is currently equipped with an Ortec GEM10P4-70-Plus HPGe detector. The system is flexible to handle different detectors. The Ortec HPGe detector was selected because it possesses many useful options. The detector uses an ultra-high count rate preamplifier for counts up to one million one MeV gamma rays processed every second (Ortec 2008). Also, the detector model has a ten percent efficiency which is sufficient since highly active samples are expected. These high activity samples can easily be counted with a ten percent efficiency detector. The detector can be seen in Figure 9, where it has been slid into one of the seven detection ports on the detection cell (middle).

#### 4. MCNP Model

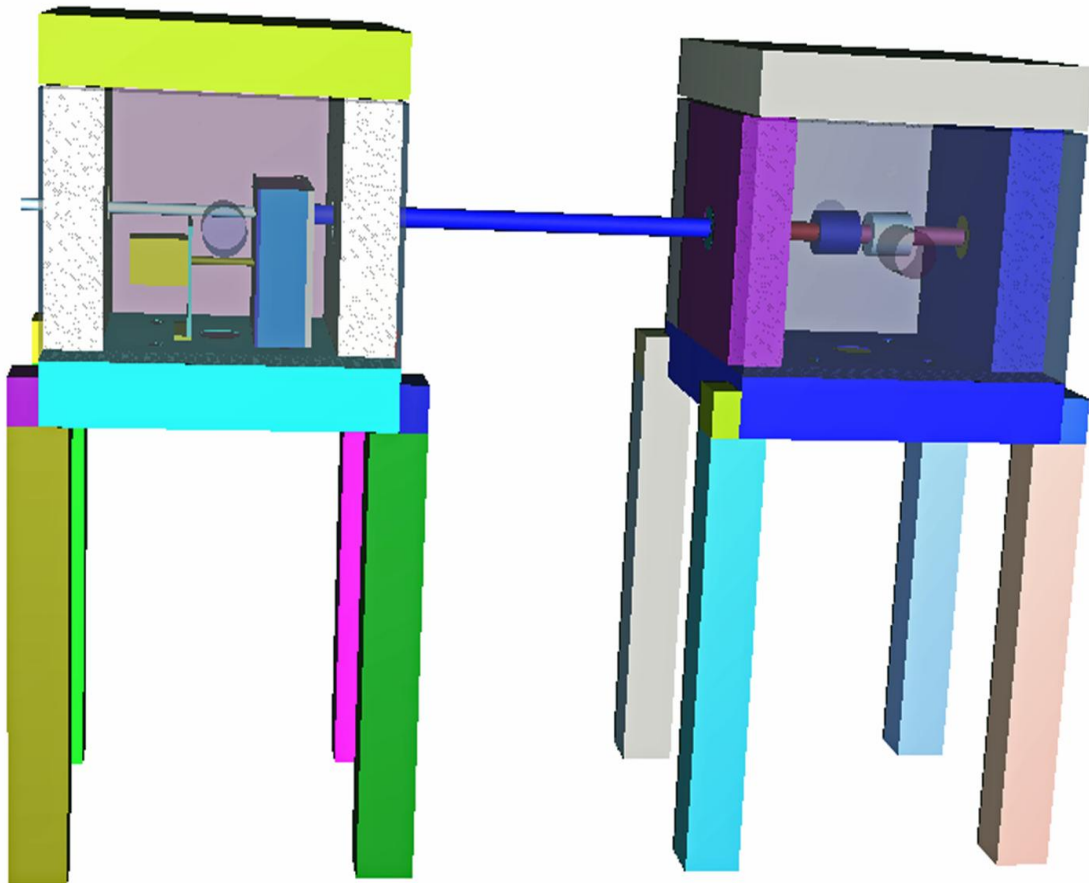

**Fig. 10.** MCNP Geometric Model

An MCNP computer model was used to help model the operational limits of the HPCR before and during construction. Knowing the maximum specimen activity is

important to insure the facility stays within 10 CFR 20 limitations. Figure 10 shows the full MCNP model with the back wall made transparent from the three-dimensional (3-D) plot.

The overall MCNP geometric model incorporates the hot cells, pneumatic assembly, and sample manipulation equipment. Monte Carlo techniques are used to predict the path of particles by a random-walk and with many particles the true behavior can be approximated (Shultis and Faw 2000).

Figure 11 shows the modeled sample revolver and step motor assembly, with the pressure box made translucent. The revolver was modeled from the exact dimensions after fabrication. The system is designed such that samples stop in the storage compartment while letting pneumatic gas continue on to the HEPA filter system.

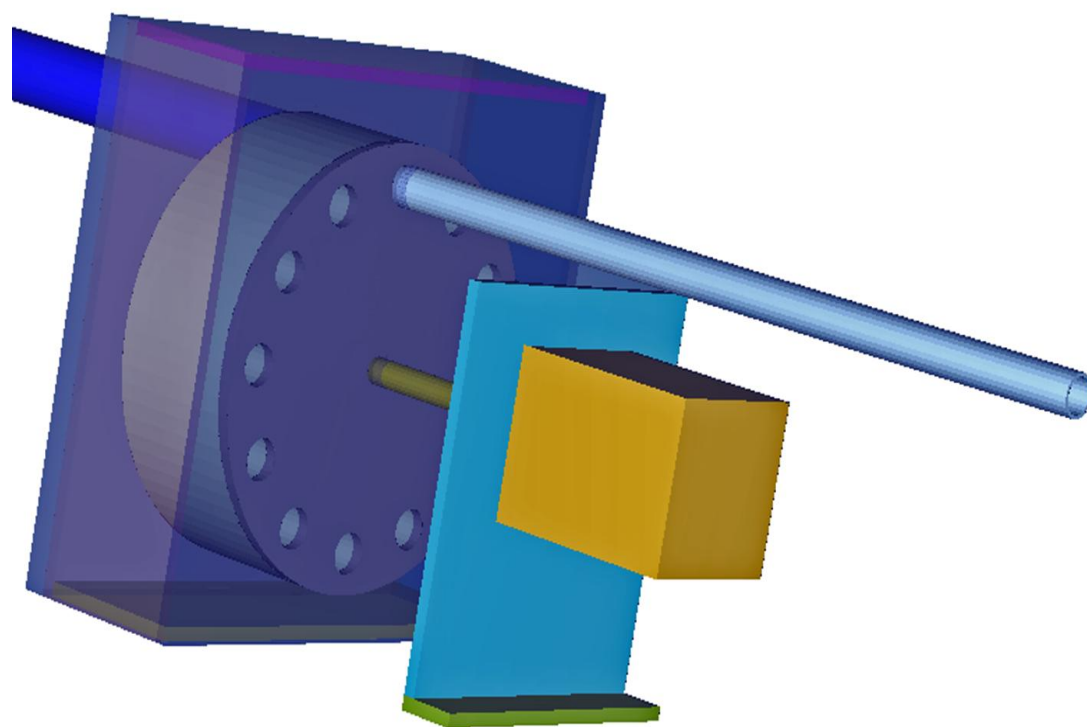

**Fig. 11.** Modeled Sample Revolver and Step Motor Assembly

## 5. MCNP Results

Dose rate field plots are useful for indicating how the dose is changing throughout the modeled hot cell. Figure 12 shows the X-Y axis along the centerline axis of a single energy 2.5 MeV gamma ray source. The units have been normalized to a dose rate per sample activity, using the ICRP-21 Gamma Flux to Dose Tables. In order to renormalize the dose rate, a FACTOR card was used with a value of 3.7E10 within the MESH tally to create the dose field in terms of mrem/hr per milliCurie of activity. The maximum dose stated by 10 CFR 20.1601 (1991) for a given radioactive sample is 100 mrem/hr 30 cm away from the source.

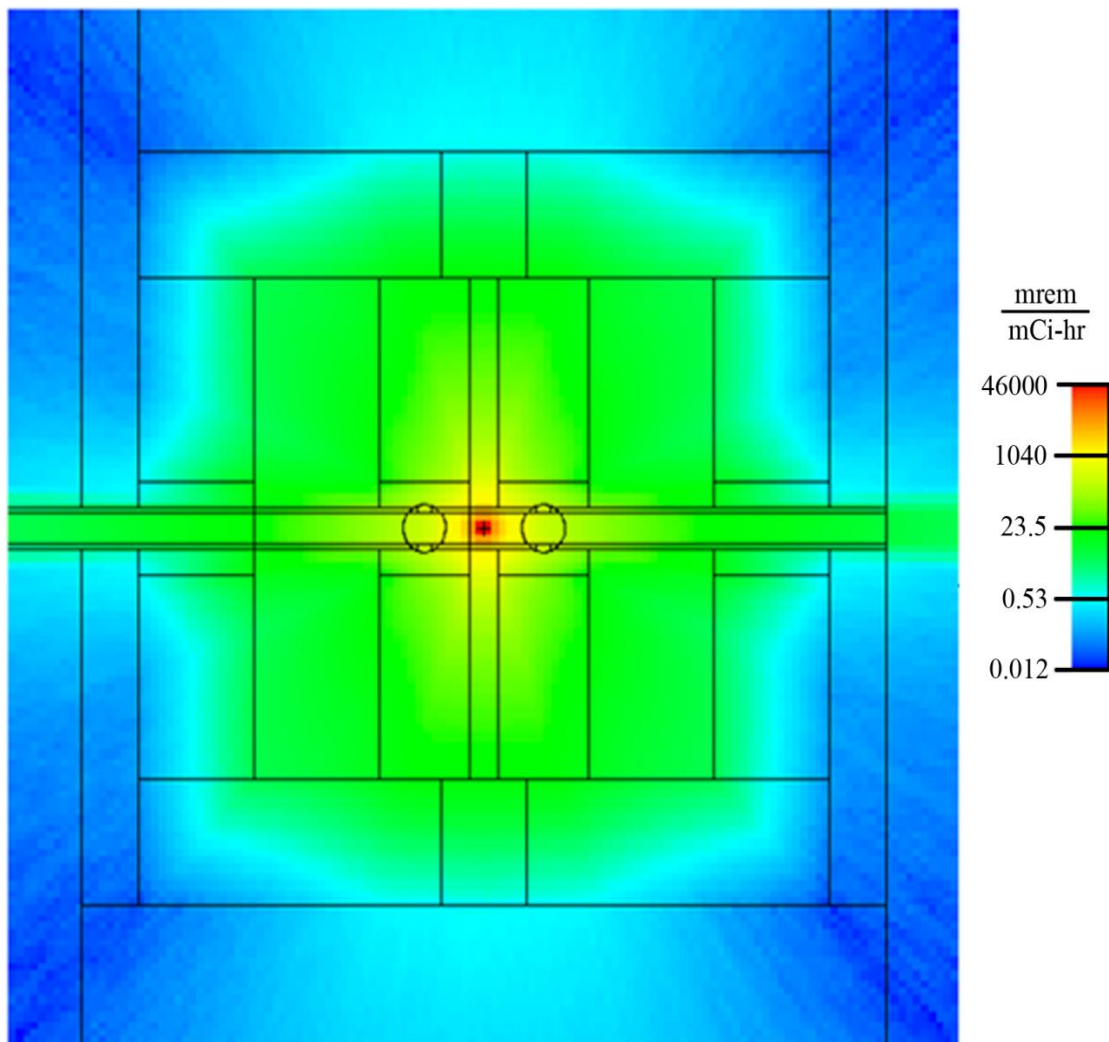

**Fig. 12.** X-Y Axis Dose Rate Plot of Counter Cell with 2.5 MeV Gamma Source (top view). Notice streaming in the pneumatic lines.

Figure 12 illustrates the most noticeable problem, which is the dose within the transfer pipe (streaming). The dose rate is much higher in this location due to the fact that there is no material other than air to attenuate radiation. There is no method to attenuate the dose within the counter cell piping besides closing the ball valves, but even when the valves are closed the pneumatic gas relief hole will still allow streaming through the tube. However, the inside of the tubing is still considered as a part of the shield and will not allow for direct streaming. The light blue dose rate around the tube is then the limiting factor due to the fact that it represents dose rates outside of the shield. Another key point is that from the center of the shield to the outside walls is 30.48 cm (12 in). The 30.48 cm matches well with the needed 30 cm defined by 10 CFR 20.1601.

In order to quantify the results harvested with MCNP, a nomenclature must be used to separate dose rates at different locations along the counter shield walls. Location A is located on the center point of the outer surface of the main three inch diameter detection port. Location C is at the center line of the pneumatic transfer tube at a location 30 cm away from the source stopping point, within the detection cell. Location B and D are on the outer surface of the detection cell half way between the center and outer edge of the pneumatic transportation piping sleeve, facing the glove box. Figure 13 shows the differences between the different locations along the counter shield boundaries. Around the pneumatic tube two locations were chosen: The first mesh cell on top and bottom of the aluminum 6061 pneumatic tube and the results did match symmetric expectations.

**Table 1.** Maximum Activity mCi with 100 mrem/hr at Shield wall

<b>Location</b>	<b>0.5 MeV</b>	<b>1.0 MeV</b>	<b>1.5 MeV</b>	<b>2.0 MeV</b>	<b>2.5 MeV</b>
<b>A</b>	2877	335	137	90	63
<b>B</b>	810	233	121	77	56
<b>C</b>	28	14	10	8	7
<b>D</b>	774	230	114	74	55

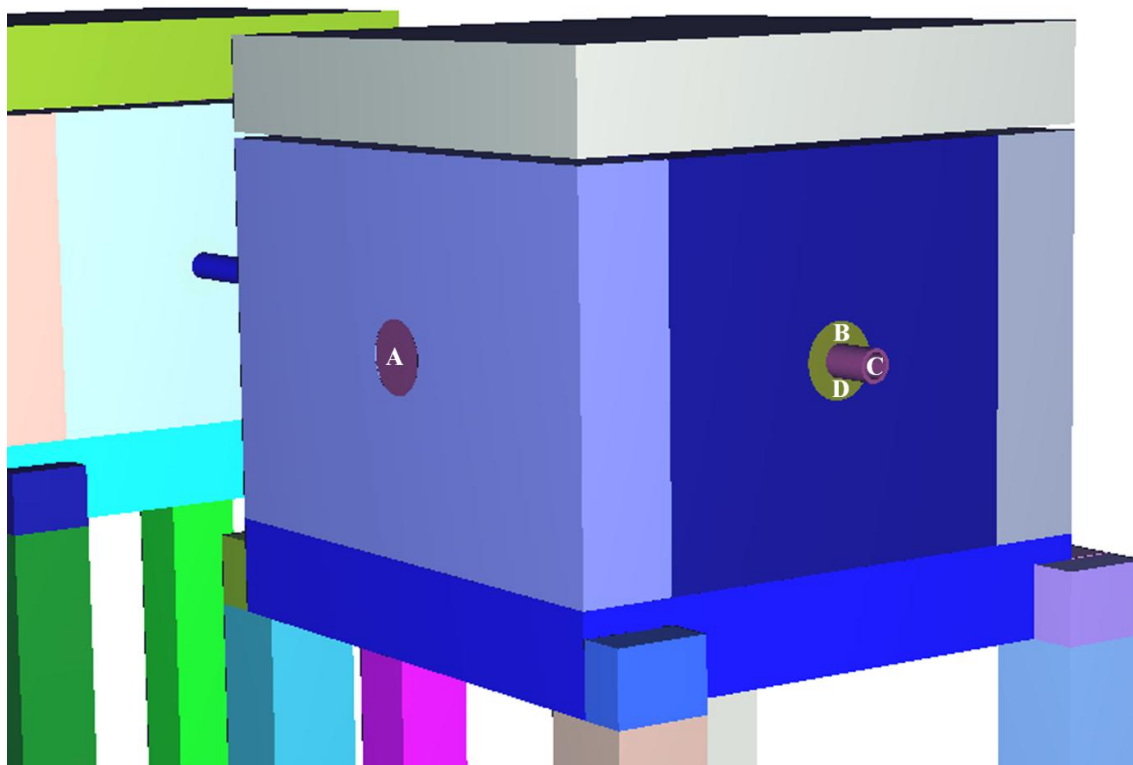
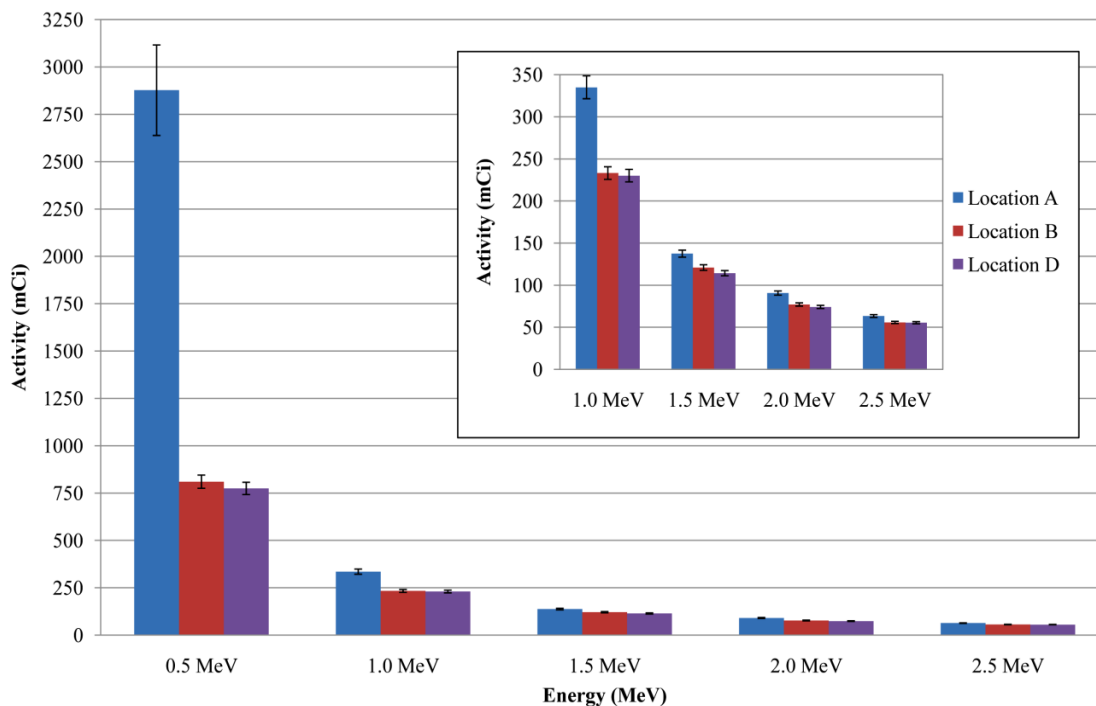

**Fig. 13.** Counter Cell Dose Rate Location Identification

When the normalized dose rates along the counter shield walls are known it is possible to find the maximum activity for a given gamma ray energy, by taking the maximum dose rate as stated by the 10 CFR 20.1601 and dividing by the normalized dose rates per milliCurie. This will result in the maximum activity at different energies which correspond to different locations along the counter shield wall. Results for the maximum activity are seen in Table 1. Random number processes such as the Monte Carlo computational techniques yield error within each result. With the MCNP code one consistent way to reduce the error in the results is by increasing the amount of source particles (X-5 Monte Carlo Team 2008).

Figure 14 shows a large maximum activity at the energy of 0.5 MeV for location A. This is due to the fact that the photons have the greatest thickness of steel to travel through and the mass attenuation coefficient of iron increases almost exponentially below 0.5 MeV (Lamarsh and Baratta 2001). Location C was omitted from Figure 10 because its location is physically within the shield and would not fall under 10 CFR 20.1601

guidelines. To clarify the maximum activity values for all photon energies greater than 1.0 MeV is expanded within Figure 14.



**Fig. 14.** Maximum Activity Around the Detection Shield

The maximum activity possible for each given gamma energy is useful for different applications but for safety the lowest value, excluding the inside of the pneumatic pipe, for each energy was selected. The lowest of the maximum activity values will yield the safest result and best measurement for a factor of safety. Figure 15 shows the results of the maximum activity for the entire radiation detection shield. A 0.75 MeV case was added to better show the maximum activity at lower photon energies.

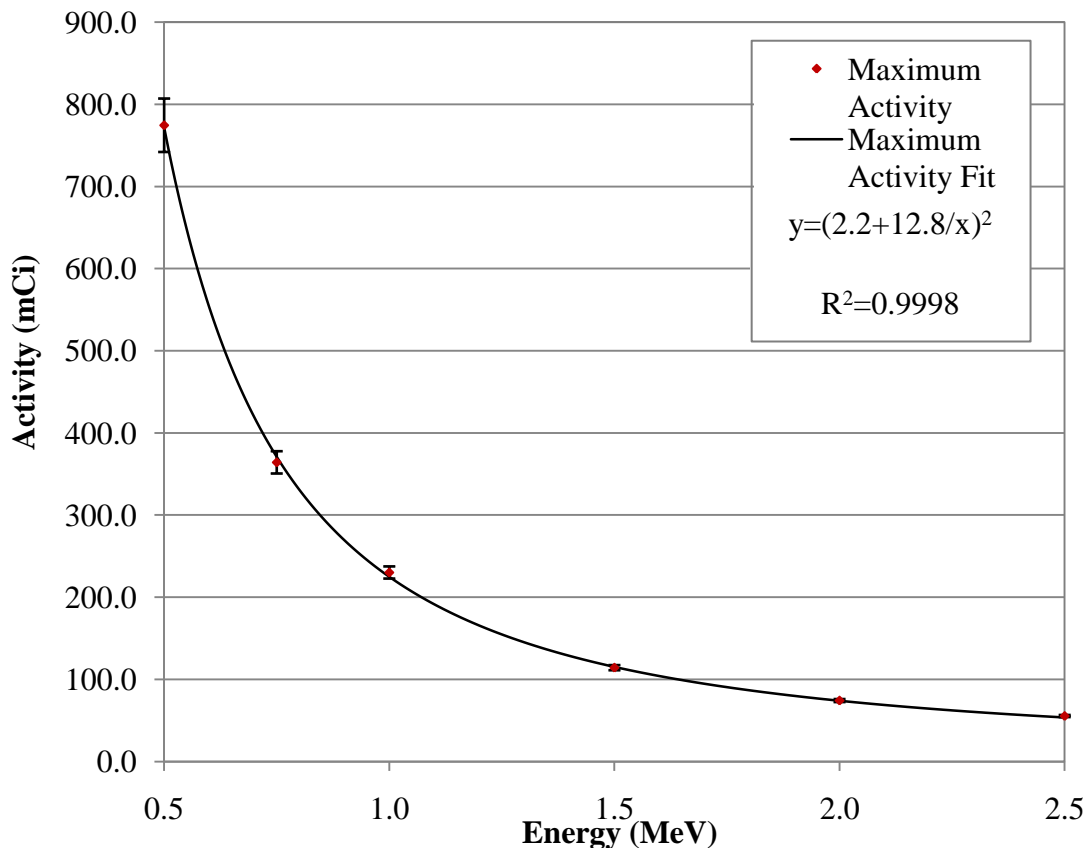

**Fig. 15.** Maximum Activity for 100 mrem/hr Dose Rate on Counter Surface

## 6. HCRT Technical Specifications

Now that the HCRT facility has been completed, it is important to inform the research community both of its research possibilities and its limitations, both of which can be seen in Table 2. Many possible samples can be irradiated. Such as fueled experiments but they are limited to a thermal power of 1 watt (Bonzer and Carrol 2009). The limit a sample can be irradiated is 8 hours due to the fact the MSTR facility is not always open all day and is closed on weekends. The maximum reactivity insertion for any experimentation must be less than 0.4%  $\Delta k/k$  (Bonzer 2008). Kulage (2010) recently characterized the thermal and fast neutron flux as  $2.94E12$  n/cm<sup>2</sup>-sec and  $2.65E12$  n/cm<sup>2</sup>-sec, respectively. Therefore, the thermal to fast fluence ratio at the HTRC is approximately 1.11.

**Table 2.** HCRT Technical Specifications

<b>Specifications</b>	
Number of samples	11
Sample size	7/8" O.D. by 2-1/4"
Sample weight	16.9 g
Types of samples	solids, liquids*, and gases*
Irradiation times	seconds to 8 hours
Detection times	seconds to days
Maximum reactor power	200 kW
Maximum dose on shield surface	100 mrem/hr
Maximum sample activity for 0.5 MeV	774.5±32.5 mCi
Maximum sample activity for 0.75 MeV	364.2±13.6 mCi
Maximum sample activity for 1.0 MeV	230.1±7.4 mCi
Maximum sample activity for 1.5 MeV	114.2±3.1 mCi
Maximum sample activity for 2.0 MeV	74.2±1.8 mCi
Maximum activity energy for 2.5 MeV	55.4±1.3 mCi
Maximum power by fueled experiment	< 1 W <sub>t</sub>
Transportation time	3 seconds
Maximum reactivity insertion	0.4% Δk/k
Thermal neutron flux	2.94E12 n/cm <sup>2</sup> -sec
Fast neutron flux	2.65E12 n/cm <sup>2</sup> -sec
<i>* Special preparations and precautions needed</i>	

## 7. Conclusion

The dual-chambered hot cell internet-accessible shielded rabbit facility at the MSTR has been built and is currently under low level irradiation testing. The facility allows remote users doing collaborative work with Missouri S&T researchers to manipulate and analyze neutron irradiated samples remotely. The system uses computer automation with user feedback to eliminate human exposure throughout the entire irradiation and measurement process. The potential to analyze multiple samples without human intervention allows the MSTR to accommodate several researchers with different needs concurrently. Finally, as the needs of Missouri S&T and its collaborators change, it is possible for the facility to expand with the addition of detection chambers, ensuring that the MSTR hot cell rabbit facility remains an important research tool for years to come.



**Acknowledgments**

This work was made possible by the DOE grant DE-FG07-07ID14852 and Missouri S&T resources. The authors greatly appreciate their support. The authors would also like to the Missouri S&T reactor staff for their support in carrying out the experimental work at the reactor facility and S&T McNutt Hall Machine shop for fabrication help.

## REFERENCES

- Anaheim Automation, Inc., DPY50601 Programmable Driver Pack User's Guide, <http://www.anaheimautomation.com/manuals/stepper/L010195%20-%20DPY50601%20Users%20Guide.pdf>, 2005
- Baum, E.M., Knox, H.D., Miller, T.R., 2002. Chart of the Nuclides, 16th edition, Lockheed Martin.
- Bonzer, W. E., 2008. Laboratory Handbook: NE206 Reaction Operations. Nuclear Engineering Department, Missouri University of Science and Technology.
- Bonzer, W. E., Personal Communication, August 2010.
- Bonzer, W. E., and Carroll, C. M., Safety Analysis Report for the Missouri University of Science and Technology Reactor, Revision 2, March 2009
- Cole-Parmer. ([http://www.coleparmer.com/catalog/product\\_view.asp?sku=0609460](http://www.coleparmer.com/catalog/product_view.asp?sku=0609460)). Accessed September 27, 2010
- “Control of Access to High Radiation Areas” *Code of Federal Regulations*. Title 10, Pt. 20.1601, 1991 ed.
- Farrell. K., Materials Selection for the HFIR Cold Neutron Source. Oak Ridge National Laboratory. ORNL/TM-99-20, 2001
- Kulage, Z.A., 2010. Characterization of the Neutron Flux Spectrum at the Missouri University of Science and Technology Research Reactor. unpublished thesis (M.S.), Missouri University of Science and Technology.
- Lamarsh, J.R. and Baratta, A.J., 2001, Introduction to Nuclear Engineering, 3<sup>rd</sup> Edition, Prentice-Hall, Inc., New Jersey, Chapter 3, pp.97
- Lin Engineering. <http://www.linengineering.com/site/products/8718.html>. Accessed October 12, 2010
- Matos, J.E., 1996, LEU Conversion Status of U.S. Research Reactors. RERTR. Argonne National Laboratory report. ANL/TD/CP-94925
- Ortec. 2008. Gem Series HPGe Coaxial Detector System. ORTEC Part Number 803406 Manual. Revision G
- Shultis, J. K. and Faw R.E., 2000, Radiation shielding, American Nuclear Society, La Grange Park, Chapter 11 pp. 408-409

X-5 Monte Carlo Team. MCNP – A General Monte N-Particle Transport Code, Version 5 Volume II: User's Guide. 2008. Los Alamos National Laboratory report, LA-UR-03-0245.

Wolbarst, A.N., 2005 Physics of Radiology, 2<sup>nd</sup> Edition, Medical Physics Publishing. Wisconsin, Chapter 8, pp. 87-89.

APPENDIX A.  
MCNP INPUT FILE

C HOT CELL INPUT DECK  
 C Bottom Counter slab/floor  
 1 2 -7.85 11 -13 -14 12 15 -6 20 21 22 23 24 VOL=37086.547 imp:p=1  
 C bottom Slab port (3")  
 2 2 -7.85 -20 -6 15 imp:p=1  
 C Upper Left Slab port (1")  
 3 2 -7.85 -21 -6 15 imp:p=1  
 C Upper Right Slab port (1")  
 4 2 -7.85 -22 -6 15 imp:p=1  
 C Lower Right Slab port (1")  
 5 2 -7.85 -23 -6 15 imp:p=1  
 C Lower Left Slab port (1")  
 6 2 -7.85 -24 -6 15 imp:p=1  
 C Right Pneumatic Wall  
 7 2 -7.85 -14 4 1 -3 6 -5 25 VOL=16317.02 imp:p=1  
 C Right Pneumatic Wall sleeve  
 8 2 -7.85 -25 -14 4 330 imp:p=1  
 C Left Pneumatic Wall  
 9 2 -7.85 -2 12 1 -3 6 -5 25 VOL=16317.02 imp:p=1  
 C Left Pneumatic Wall Sleeve  
 10 2 -7.85 -2 -25 12 330 imp:p=1  
 C cell wall near concrete outer reactor wall  
 11 2 -7.85 -14 12 -13 3 6 -5 26 VOL=37292.462 imp:p=1  
 C port near concrete outer reactor wall  
 12 2 -7.85 3 -13 -26 imp:p=1  
 C Detector wall  
 13 2 -7.85 11 -1 -14 12 6 -5 26 VOL=37292.462 imp:p=1  
 C Detector's wall port  
 14 2 -7.85 11 -1 -26 imp:p=1  
 C  
 C top Cell lid  
 15 2 -7.85 27 -28 -13 12 -14 11 imp:p=1  
 C  
 C Central air pocket  
 C 16 3 -0.0012 -3 2 1 -4 6 -5 330 imp:p=1  
 C  
 C  
 C  
 C Legs to Counter Cell assume solid  
 C -----  
 C  
 C Upper left Leg  
 C front concrete wall, left leg (main lower section)  
 30 2 -7.85 -15 37 -32 33 30 -31 imp:p=1  
 C front concrete wall, left leg (upper weld section part a)  
 31 2 -7.85 15 -36 -32 -31 13 12 imp:p=1  
 C front concrete wall, left leg (upper weld section part b )

32 2 -7.85 15 -36 -32 30 33 -12 imp:p=1  
C  
C Upper right Leg  
33 2 -7.85 -15 37 -32 33 -34 35 imp:p=1  
C front concrete wall, right leg (upper weld section part a )  
34 2 -7.85 15 -36 35 -32 13 -14 imp:p=1  
C front concrete wall, right leg (upper weld section part b )  
35 2 -7.85 15 -36 -32 -34 33 14 imp:p=1  
C  
C Lower right leg  
36 2 -7.85 -15 37 -34 35 -1 11 VOL=imp:p=1  
C Lower Right leg (upper weld section full section)  
37 2 -7.85 15 -36 -1 -34 14 11 imp:p=1  
C  
C Lower left leg  
38 2 -7.85 -15 37 -1 11 -31 30 imp:p=1  
C lower left leg (upper weld section, full section)  
39 2 -7.85 15 -36 -1 30 11 -12 imp:p=1  
C  
C Air under Counter cell  
C Air from front wall to back  
40 3 -0.0012 -32 31 -35 11 37 -15 imp:p=1  
C left side air  
41 3 -0.0012 -33 -31 30 1 37 -15 imp:p=1  
C right side air  
42 3 -0.0012 -33 -34 35 1 37 -15 imp:p=1  
C air around cell  
C Small air around front concrete welds  
43 3 -0.0012 31 -35 13 -32 15 -36 imp:p=1  
C Small small around right welds  
44 3 -0.0012 -33 14 -34 1 15 -36 imp:p=1  
C small around left side side welds  
45 3 -0.0012 30 -12 -33 1 15 -36 imp:p=1  
C  
C Detector side full air box (CHANGE TO ADD DETECTOR)  
46 3 -0.0012 -11 900 30 -34 37 -902 imp:p=1  
C Air between box and lid  
47 3 -0.0012 -13 -14 12 11 5 -27 imp:p=1  
C Air above Counter lid  
48 3 -0.0012 28 -902 -13 12 -14 11 imp:p=1  
C small air gap on left of cell wall  
49 3 -0.0012 -12 30 11 -901 36 -902 330 VOL=43413.687 imp:p=1  
C small air gap on right of cell wall  
50 3 -0.0012 14 -34 11 -901 36 -902 330 VOL=43413.687 imp:p=1  
C Small air box in front for possible other detector  
51 3 -0.0012 13 -901 12 -14 36 -27 imp:p=1  
C air above front detector air box

52 3 -0.0012 27 -902 12 -14 13 -901 imp:p=1  
 C Front lower box of air against concrete  
 53 3 -0.0012 37 -36 -901 32 30 -34 imp:p=1  
 C  
 C  
 C Left air Surrounding  
 100 3 -0.0012 -1030 -901 900 903 -902 37 imp:p=1  
 C Center air Surrounding  
 101 3 -0.0012 -902 37 1034 -30 -901 900 330 imp:p=1  
 C Right Air Surrounding  
 102 3 -0.0012 -901 900 34 -904 -902 37 imp:p=1  
 C  
 C  
 C  
 C MAIN VOID  
 103 0 901:-903:-900:904:902:-37 imp:p=0  
 C  
 C  
 C  
 C -----  
 C Below defines the storage hot cell cards 500-  
 C -----  
 C  
 C  
 C Bottom Storage slab/floor  
 501 2 -7.85 11 -13 -1014 1012 15 -6 1020 1021 1022 1023 1024 &  
     VOL=37086.547 imp:p=1  
 C bottom Slab port (3")  
 502 2 -7.85 -1020 -6 15 imp:p=1  
 C Upper Left Slab port (1")  
 503 2 -7.85 -1021 -6 15 imp:p=1  
 C Upper Right Slab port (1")  
 504 2 -7.85 -1022 -6 15 imp:p=1  
 C Lower Right Slab port (1")  
 505 2 -7.85 -1023 -6 15 imp:p=1  
 C Lower Left Slab port (1")  
 506 2 -7.85 -1024 -6 15 imp:p=1  
 C Right Pneumatic Wall  
 507 2 -7.85 -1014 1004 1 -3 6 -5 25 VOL=16317.02 imp:p=1  
 C Right Pneumatic Wall sleeve  
 508 2 -7.85 -25 -1014 1004 330 imp:p=1  
 C Left Pneumatic Wall  
 509 2 -7.85 -1002 1012 1 -3 6 -5 25 VOL=16317.02 imp:p=1  
 C Left Pneumatic Wall Sleeve  
 510 2 -7.85 -1002 -25 1012 701 imp:p=1  
 C cell wall near concrete outer reactor wall  
 511 2 -7.85 -1014 1012 -13 3 6 -5 1026 VOL=37292.462 imp:p=1

C port near concrete outer reactor wall  
 512 2 -7.85 3 -13 -1026 imp:p=1  
 C Detector wall  
 513 2 -7.85 11 -1 -1014 1012 6 -5 1026 VOL=37292.462 imp:p=1  
 C Detector's wall port  
 514 2 -7.85 11 -1 -1026 imp:p=1  
 C  
 C Central air pocket \*\*\*\* HAS THE REVOLVER \*\*\*\*\*  
 C 515 2 -7.85 -3 1002 1 -1004 6 -5 imp:p=1  
 C  
 C top Cell lid  
 516 2 -7.85 27 -28 -13 1012 -1014 11 imp:p=1  
 C  
 C  
 C Legs to Storage Cell assume solid  
 C -----  
 C  
 C Upper left Leg  
 C front concrete wall, left leg (main lower section)  
 530 2 -7.85 -15 37 -32 33 1030 -1031 imp:p=1  
 C front concrete wall, left leg (upper weld section part a)  
 531 2 -7.85 15 -36 -32 -1031 13 1012 imp:p=1  
 C front concrete wall, left leg (upper weld section part b )  
 532 2 -7.85 15 -36 -32 1030 33 -1012 imp:p=1  
 C  
 C Upper right Leg  
 533 2 -7.85 -15 37 -32 33 -1034 1035 imp:p=1  
 C front concrete wall, right leg (upper weld section part a )  
 534 2 -7.85 15 -36 1035 -32 13 -1014 imp:p=1  
 C front concrete wall, right leg (upper weld section part b )  
 535 2 -7.85 15 -36 -32 -1034 33 1014 imp:p=1  
 C  
 C Lower right leg  
 536 2 -7.85 -15 37 -1034 1035 -1 11 imp:p=1  
 C Lower Right leg (upper weld section full section)  
 537 2 -7.85 15 -36 -1 -1034 1014 11 imp:p=1  
 C  
 C Lower left leg  
 538 2 -7.85 -15 37 -1 11 -1031 1030 imp:p=1  
 C lower left leg (upper weld section, full section)  
 539 2 -7.85 15 -36 -1 1030 11 -1012 imp:p=1  
 C  
 C Air under Counter cell  
 C Air from front wall to back  
 540 3 -0.0012 -32 1031 -1035 11 37 -15 imp:p=1  
 C left side air  
 541 3 -0.0012 -33 -1031 1030 1 37 -15 imp:p=1



C right side air  
 542 3 -0.0012 -33 -1034 1035 1 37 -15 imp:p=1  
 C air around cell  
 C Small air around front concrete welds  
 543 3 -0.0012 1031 -1035 13 -32 15 -36 imp:p=1  
 C Small small around right welds  
 544 3 -0.0012 -33 1014 -1034 1 15 -36 imp:p=1  
 C small around left side side welds  
 545 3 -0.0012 1030 -1012 -33 1 15 -36 imp:p=1  
 C  
 C Detector side full air box (CHANGE TO ADD DETECTOR)  
 546 3 -0.0012 -11 900 1030 -1034 37 -902 imp:p=1  
 C Air between box and lid  
 547 3 -0.0012 -13 -1014 1012 11 5 -27 imp:p=1  
 C Air above Counter lid  
 548 3 -0.0012 28 -902 -13 1012 -1014 11 imp:p=1  
 C small air gap on left of cell wall  
 549 3 -0.0012 -1012 1030 11 -901 36 -902 701 VOL=43413.687 imp:p=1  
 C small air gap on right of cell wall  
 550 3 -0.0012 1014 -1034 11 -901 36 -902 330 VOL=43413.687 imp:p=1  
 C Small air box in front "near wall" for possible other detector  
 551 3 -0.0012 13 -901 1012 -1014 36 -27 imp:p=1  
 C air above front detector air box  
 552 3 -0.0012 27 -902 1012 -1014 13 -901 imp:p=1  
 C Front lower box of air against concrete  
 553 3 -0.0012 37 -36 -901 32 1030 -1034 imp:p=1  
 C  
 C -----  
 C Cells below define the Pressure box  
 C -----  
 C gas relief part of cylinder  
 701 4 -2.7 -301 303 -304 701 702 703 704 705 706 707 708 709 710 711 712 305  
 VOL= 28.958 imp:p=1  
 C gas relief stream free slot 12 o'clock  
 702 3 -0.0012 -701 303 -304 imp:p=1  
 C gas relief slot 1 o'clock  
 703 3 -0.0012 -702 303 -304 imp:p=1  
 C gas relief slot 2 o'clock  
 704 3 -0.0012 -703 303 -304 imp:p=1  
 C gas relief slot 3 o'clock  
 705 3 -0.0012 -704 303 -304 imp:p=1  
 C gas relief slot 4 o'clock  
 706 3 -0.0012 -705 303 -304 imp:p=1  
 C gas relief slot 5 o'clock  
 707 3 -0.0012 -706 303 -304 imp:p=1  
 C gas relief slot 6 o'clock  
 708 3 -0.0012 -707 303 -304 imp:p=1

C gas relief slot 7 o'clock  
709 3 -0.0012 -708 303 -304 imp:p=1

C gas relief slot 8 o'clock  
710 3 -0.0012 -709 303 -304 imp:p=1

C gas relief slot 9 o'clock  
711 3 -0.0012 -710 303 -304 imp:p=1

C gas relief slot 10 o'clock  
712 3 -0.0012 -711 303 -304 imp:p=1

C gas relief slot 11 o'clock  
713 3 -0.0012 -712 303 -304 imp:p=1

C

C Sample storage part of cylinder  
720 4 -2.7 304 -302 -301 601 602 603 604 605 606 607 608 609 610 611 612 305  
VOL=1840.463 imp:p=1

C storage spot stream free slot 12 o'clock  
721 3 -0.0012 -601 304 -302 imp:p=1

C storage spot slot 1 o'clock  
722 3 -0.0012 -602 304 -302 imp:p=1

C storage spot slot 2 o'clock  
723 3 -0.0012 -603 304 -302 imp:p=1

C storage spot slot 3 o'clock  
724 3 -0.0012 -604 304 -302 imp:p=1

C storage spot slot 4 o'clock  
725 3 -0.0012 -605 304 -302 imp:p=1

C storage spot slot 5 o'clock  
726 3 -0.0012 -606 304 -302 imp:p=1

C storage spot slot 6 o'clock  
727 3 -0.0012 -607 304 -302 imp:p=1

C storage spot slot 7 o'clock  
728 3 -0.0012 -608 304 -302 imp:p=1

C storage spot slot 8 o'clock  
729 3 -0.0012 -609 304 -302 imp:p=1

C storage spot slot 9 o'clock  
730 3 -0.0012 -610 304 -302 imp:p=1

C storage spot slot 10 o'clock  
731 3 -0.0012 -611 304 -302 imp:p=1

C storage spot slot 11 o'clock  
732 3 -0.0012 -612 304 -302 imp:p=1

C

C

C Axle  
750 1 -7.92 -305 371 -323 imp:p=1

C bearing  
751 1 -7.92 318 -323 -322 305 imp:p=1

C other side of bearing (rest of right side pressure box)  
753 4 -2.7 -322 323 -319 imp:p=1

C

C  
 C Pressure box  
 C  
 C Concrete Wall side  
 760 4 -2.7 -311 6 314 -315 320 -318 imp:p=1  
 C Near you  
 761 4 -2.7 -311 6 317 -316 320 -318 imp:p=1  
 C right  
 762 4 -2.7 -319 318 -311 6 -315 317 322 330 VOL=813.135 imp:p=1  
 C left  
 763 4 -2.7 321 -320 -311 6 -315 317 305 701 VOL=409.676 imp:p=1  
 C top  
 764 4 -2.7 310 -311 -314 316 320 -318 imp:p=1  
 C bottom  
 765 4 -2.7 6 -312 -314 316 320 -318 imp:p=1  
 C  
 C air in Pressure box  
 C left air in Pressure box  
 766 3 -0.0012 -301 320 -303 305 701 VOL=102.963 imp:p=1  
 C outter air in Pressure box  
 767 3 -0.0012 -310 320 -318 312 316 -314 301 VOL=2335.419 imp:p=1  
 C right air in Pressure box  
 768 3 -0.0012 -301 302 -318 305 330 VOL=102.963 imp:p=1  
 C  
 C Sample pneumatic pipe in Pressure box  
 770 4 -2.7 302 -330 601 -2 imp:p=1  
 C air in sample pneumatic pipe, in Pressure box  
 771 3 -0.0012 302 -2 -601 imp:p=1  
 C Air return pneumatic pipe, in Pressure box  
 772 4 -2.7 -701 1030 -303 331 imp:p=1  
 C Air in Return pneumatic pipe, in Pressure box  
 773 3 -0.0012 -331 1030 -303 imp:p=1  
 C  
 C Stepping motor stand  
 780 1 -7.92 -370 371 312 -372 -373 374 305 VOL=151.526 imp:p=1 \$vertical riser  
 781 4 -2.7 -370 375 -312 6 -373 374 imp:p=1 \$ bottom lifter plate  
 C  
 C step motor  
 782 1 -7.92 -371 380 -381 382 -383 384 imp:p=1 \$ the step motor  
 C Air around revolver "useless in full model  
 C 800 3 -0.0012 -1002:1004:3:-1:5:-6 imp:p=1  
 C  
 C Fill air in storage cell  
 C top air  
 801 3 -0.0012 311 -5 -3 1 -1004 1002 imp:p=1  
 C right of revolver setup air  
 802 3 -0.0012 319 -1004 -3 1 6 -311 330 VOL=5221.605 imp:p=1

C air near concrete wall (on side of the revolver)  
 803 3 -0.0012 -311 6 315 -3 1002 -319 imp:p=1  
 C air near you (on side of the revolver)  
 804 3 -0.0012 -311 6 1 -317 1002 -319 imp:p=1  
 C air around step motor  
 805 3 -0.0012 -311 312 1002 -371 -315 317 701 (-380:383:-384:381:-382)  
 VOL=13845.955 imp:p=1  
 C air around vertical riser  
 806 3 -0.0012 -311 312 -315 317 371 -370 701 (373:-374:372) VOL=189.41 imp:p=1  
 C Bottom air sliver  
 807 3 -0.0012 6 -312 1002 -370 -315 317 (373:-375:-374) imp:p=1  
 C Between Vertical riser and pressure box  
 808 3 -0.0012 -311 6 370 -321 -315 317 305 701 VOL=11547.08 imp:p=1  
 C  
 C  
 C below is for the ball valves  
 C left ball valve  
 901 1 -7.92 -401 402 403 VOL=12.4998 imp:p=1  
 C Left Transport hole  
 902 3 -0.0012 -401 -402 imp:p=1  
 C Left exhaust hole  
 903 3 -0.0012 -401 -403 402 VOL=4.826 imp:p=1  
 C Air in Left transport tube  
 904 3 -0.0012 -601 401 2 -408 imp:p=1  
 C Left pipe  
 906 4 -2.7 -330 601 401 2 -408 imp:p=1  
 C Left ball assymb.  
 908 1 -7.92 407 -25 -408 330 401 imp:p=1  
 C left air in box  
 909 3 -0.0012 2 -5 -407 6 330 -3 1 VOL=16102.62 imp:p=1  
 C right air in box  
 C 10 3 -0.0012 408 -410 -5 6 330 -3 1 imp:p=1  
 C air around left valve in box  
 911 3 -0.0012 -5 6 25 407 -408 -3 1 VOL=12080.69 imp:p=1  
 C right ball valve  
 912 1 -7.92 -411 402 413 VOL=12.4998 imp:p=1  
 C Right transport hole  
 913 3 -0.0012 -411 -412 imp:p=1  
 C right exhaust hole  
 914 3 -0.0012 -411 -413 412 VOL=4.826 imp:p=1  
 C Right pipe  
 915 4 -2.7 -330 601 411 408 -34 imp:p=1  
 C air in right pipe  
 916 3 -0.0012 -601 411 408 -34 imp:p=1  
 C Right ball assembly  
 917 1 -7.92 -25 409 -410 330 411 imp:p=1  
 C Air around right valve

918 3 -0.0012 25 409 -410 -5 6 -3 1 VOL=12080.69 imp:p=1

C Central air pocket

919 3 -0.0012 -5 6 -3 1 408 -409 330 VOL=3744.795 imp:p=1

C Right air pocket

920 3 -0.0012 -5 6 -3 -4 410 1 330 VOL=16102.62 imp:p=1

C Below is the blank line between cell & surface cards

C -----

C Below defines the counter hot cell surfaces

C -----

C

C Inside wall planes (without lid)

1 py -20.32

2 px -20.32

3 py 20.32

4 px 20.32

5 pz 28.575

6 pz -12.065

C Outside wall planes (without lid)

11 py -30.48

12 px -30.48

13 py 30.48

14 px 30.48

15 pz -22.225

C slab/Floor ports

20 cz 3.81 \$ center 3" hole

21 1 cz 1.27 \$ smal-1 1" port (upper left)

22 2 cz 1.27 \$ small 1" port (upper right)

23 3 cz 1.27 \$ small 1" port (lower left)

24 4 cz 1.27 \$ small 1" port (lower right)

C Detector and opposite wall port

25 c/x 0 8.255 3.81 \$ 3" port

C Pneumatic wall ports

26 c/y 0 8.255 3.81 \$3" port

C

C AIR GAP FOR LID (1/4" gap)

27 pz 29.21 \$ top of cell + 1/4" of gap

C

C lid Thickness

28 pz 39.365 \$ Surface 27 + 4"

C

C Cell legs (two inch over hang) & just vertical, not slanted

C Cell wall surface 1 = front surface of back legs

C -----

C outer leg wall

30 px -35.56

31 px -25.4

32 py 35.56  
 33 py 25.4  
 34 px 35.56  
 35 px 25.4  
 C vertical leg walls  
 36 pz -14.605 \$ top of leg, (bottom of slab + 3")  
 37 pz -95.885 \$ bottom of leg and concrete surface  
 C  
 C  
 C OUTER Air boundary lines  
 900 py -121.92 \$ back boundary (surface 11 + 3')  
 901 py 53.34 \$ front outer cell wall + 7" (to concrete surface)  
 902 pz 86.995 \$ total height is 6' (surface 37 + 6')  
 903 px -203.2 \$ left outer storage wall + 1.5' air  
 904 px 81.28 \$ right outer counter wall + 1.5' air  
 C  
 C  
 C  
 C -----  
 C Below defines the Storage hot cell surfaces  
 C  
 C The same as the counter cell but ALL PX surfaces are TRCL over by 121.92 cm  
 C \*\*\* Take same surface but change to 1000 + old surface # \*\*\*  
 C -----  
 C  
 1002 50 px -20.32  
 1004 50 px 20.32  
 C Outside wall planes (without lid)  
 1012 50 px -30.48  
 1014 50 px 30.48  
 C slab/Floor ports  
 1020 50 cz 3.81 \$ center 3" hole  
 1021 11 cz 1.27 \$ smal-1 1" port (upper left)  
 1022 12 cz 1.27 \$ small 1" port (upper right)  
 1023 13 cz 1.27 \$ small 1" port (lower left)  
 1024 14 cz 1.27 \$ small 1" port (lower right)  
 1026 50 c/y 0 8.255 3.81 \$ 3" port  
 C  
 C Cell legs (two inch over hang) & just vertical, not slanted  
 C Cell wall surface 1 = front surface of back legs  
 C -----  
 C outer leg wall  
 1030 50 px -35.56  
 1031 50 px -25.4  
 1034 50 px 35.56  
 1035 50 px 25.4  
 C

C =====

C

C

C -----

C Below defines the Revolver Pressure box surfaces

C

C -----

C

C for storage box (inside surfaces)

C The 6 below surfaces are only good for revolver model by itself

C 1004 500 px 10.4775 \$ surface 1004

C 1002 500 px -30.1625 \$ surface 1002

C 3 py 20.32 \$ surface 3

C 1 py -20.32 \$ surface 1

C 5 pz 28.575 \$ surface 5

C 6 pz -12.065 \$ surface 6

C

C

301 cx 10.16 \$ revolver

302 500 px 3.81 \$ right side of revolver

303 500 px -3.81 \$ Left side of revolver

C for .25" thick return line

304 500 px -3.175 \$ Split revolver in two separate cylinders for easy TRCL card

C

C For steel axle

305 cx 0.635 \$ for cylinder support and rotation

C

C surfaces for pressure box 3.25" inside thickness

310 pz 12.7

311 pz 13.335

312 pz -11.43

C 313 pz -12.065 \$ same as the bottom of the cell floor

314 py 12.065

315 py 12.70

316 py -12.065

317 py -12.70

318 500 px 4.1275

319 500 px 5.3975 \$ for the full 0.5" plate

320 500 px -4.1275

321 500 px -4.7625

C axle bearing

322 cx 1.42875 \$ OD of bearing is 1-1/8"

323 500 px 4.7625 \$ 1/4" stop point for bearing

C

C surfaces for pipe openings

330 c/x 0 8.255 1.67005 \$ sample pneumatic pipe OD

C surface 601 is the same as the 1" sample pneumatic pipe ID

C surface 701 is the same as the 0.75" air pneumatic pipe OD

331 c/x 0 8.255 0.7874 \$ air pneumatic pipe ID (0.62")

C

C Stand for stepping motor

370 500 px -15.97 \$ right side of vertical riser

371 500 px -16.605 \$ left side of vertical riser

372 pz 6.35 \$ top of vertical riser

373 py 7.62 \$ side of vertical riser near concrete wall

374 py -7.62 \$ side of vertical riser facing you

375 500 px -19.05 \$ left side of the bottom lifter plate for stand (2")

C

C For step motor

380 500 px -27.035 \$ left side of motor

381 py 3.81 \$ side near concrete wall

382 py -3.81 \$ side near you

383 pz 3.81 \$ Top of motor

384 pz -3.81 \$ Bottom of motor

C

C BELOW is for the BALL VALVES

C \*\*\*\*\* ADD TR11 to surface 402 & 403 if the ball valve is close \*\*\*\*\*

C the 3 surfaces below define the Left ball valve rotator

401 s -5.27 0 8.255 1.905 \$ ball valve (0.75" radius)

402 c/x 0 8.255 1.2446 \$ transport hole (0.98" dia.)

403 c/y -5.27 8.255 0.635 \$ exhaust gas hole (0.5" dia)

C below defines the outer assyemby and pipe

C 601 c/x 0 8.255 1.27 \$ inside of transport tube ID (1")

C 330 c/x 0 8.255 1.67005 \$ outside of transport tube OD (1.315")

C 406 c/x 0 8.255 3.81 \$ outside of ball valve assym... (1.5" radius)

407 px -9.27 \$ left bound on left valve

408 px -1.27 \$ right bound on left valve

409 px 1.27 \$ left bound on right valve

410 px 9.27 \$ right bound on right valve

C The 2 below surfaces define the Right ball valve rotator

411 s 5.27 0 8.255 1.905 \$ ball valve (0.75" radius)

412 c/x 0 8.255 1.2446 \$ transport hole (0.98" dia.)

413 c/y 5.27 8.255 0.635 \$ exhaust gas hole (0.5" dia)

C Stops pipe @ CL of detector

C 450 px 0

C

C

C Gas relief stop space = S.S.S

C surface 701 is the same as the 0.75" return pneumatic pipe

701 c/x 0 8.255 0.9525 \$ 3/4" diameter S.S; 12 o'clock

702 101 c/x 0 8.255 0.9525 \$ 3/4" diameter S.S; 1 o'clock

703 102 c/x 0 8.255 0.9525 \$ 3/4" diameter S.S; 2 o'clock

704 103 c/x 0 8.255 0.9525 \$ 3/4" diameter S.S; 3 o'clock

705 104 c/x 0 8.255 0.9525 \$ 3/4" diameter S.S; 4 o'clock



706 105 c/x 0 8.255 0.9525 \$ 3/4" diameter S.S; 5 o'clock  
 707 106 c/x 0 8.255 0.9525 \$ 3/4" diameter S.S; 6 o'clock  
 708 107 c/x 0 8.255 0.9525 \$ 3/4" diameter S.S; 7 o'clock  
 709 108 c/x 0 8.255 0.9525 \$ 3/4" diameter S.S; 8 o'clock  
 710 109 c/x 0 8.255 0.9525 \$ 3/4" diameter S.S; 9 o'clock  
 711 110 c/x 0 8.255 0.9525 \$ 3/4" diameter S.S; 10 o'clock  
 712 111 c/x 0 8.255 0.9525 \$ 3/4" diameter S.S; 11 o'clock

C sample storage space = S.S.S

601 c/x 0 8.255 1.27 \$ 1" diameter S.S.S 12 o'clock  
 602 101 c/x 0 8.255 1.27 \$ 1" diameter S.S.S 1 o'clock  
 603 102 c/x 0 8.255 1.27 \$ 1" diameter S.S.S 2 o'clock  
 604 103 c/x 0 8.255 1.27 \$ 1" diameter S.S.S 3 o'clock  
 605 104 c/x 0 8.255 1.27 \$ 1" diameter S.S.S 4 o'clock  
 606 105 c/x 0 8.255 1.27 \$ 1" diameter S.S.S 5 o'clock  
 607 106 c/x 0 8.255 1.27 \$ 1" diameter S.S.S 6 o'clock  
 608 107 c/x 0 8.255 1.27 \$ 1" diameter S.S.S 7 o'clock  
 609 108 c/x 0 8.255 1.27 \$ 1" diameter S.S.S 8 o'clock  
 610 109 c/x 0 8.255 1.27 \$ 1" diameter S.S.S 9 o'clock  
 611 110 c/x 0 8.255 1.27 \$ 1" diameter S.S.S 10 o'clock  
 612 111 c/x 0 8.255 1.27 \$ 1" diameter S.S.S 11 o'clock

C Below is the blank line between surface & data cards

C Data Cards

C -----

C

C Transforms for Hot cells

C -----

C for floor/base (set at 4.5" offset both X & Y)

TR1 -11.43 11.43 0 \$start at upper left

TR2 11.43 11.43 0 \$CCW from 1

TR3 11.43 -11.43 0 \$CCW from 2

TR4 -11.43 -11.43 0 \$CCW from 3

C

C transforms all floor cz 1" port surfaces for Storage cell; -4' from x axis

TR11 -133.35 11.43 0 \$start at upper left

TR12 -110.49 11.43 0 \$CCW from 1

TR13 -110.49 -11.43 0 \$CCW from 2

TR14 -133.35 -11.43 0 \$CCW from 3

C

C The next transform moves all px cards over for storage cell, 4' was selected

C due to the fact that from Center line (CL) to CL is 4' between the two cells

C

TR50 -121.92 0 0 \$ moves all px cards and the floor 3" port over 4' in - x.

C

C

C Transforms for revolver pressure box

C -----

```

C translations ++++++ON XY PLANE!!!+++++ CW from 12 o'clock ++++++
C Sample space on revolver translations *****
*TR101 0 0 0 0 90 90 90 30 120 90 60 30 1 $ 30 degree rotate
*TR102 0 0 0 0 90 90 90 60 150 90 30 60 1 $ 60 degree rotate
C *TR103 is also for rotating the ball valves
*TR103 0 0 0 0 90 90 90 90 180 90 0 90 1 $ 90 degree rotate
*TR104 0 0 0 0 90 90 90 120 150 90 30 120 1 $ 120 degree rotate
*TR105 0 0 0 0 90 90 90 150 120 90 60 150 1 $ 150 degree rotate
*TR106 0 0 0 0 90 90 90 180 90 90 90 180 1 $ 180 degree rotate
*TR107 0 0 0 0 90 90 90 150 60 90 120 150 1 $ 210 degree rotate
*TR108 0 0 0 0 90 90 90 120 30 90 150 120 1 $ 240 degree rotate
*TR109 0 0 0 0 90 90 90 90 0 90 180 90 1 $ 270 degree rotate
*TR110 0 0 0 0 90 90 90 60 30 90 150 60 1 $ 300 degree rotate
*TR111 0 0 0 0 90 90 90 30 60 90 120 30 1 $ 330 degree rotate
TR500 -111.225 0 0 $moves all surfaces to storage cell location.
C -----
C
C -----
C SOURCE CARDS
mode p
sdef erg=1.5 pos=-111 -8.2772 0 par=2 $ A source of 1.5 MeV photons
C -----
C Tallies
C
C Fmesh *****
FMESH4:P GEOM=rec ORIGIN= -158 -42 -42 IMESH=0 IINTS=474 &
    JMESH=42 JINTS=126 KMESH=42 KINTS=126 OUT=col FACTOR=3.7E10 $ mrem/mCi
C
C flux to dose convert using ICRP-21 standard
DE0 LOG 0.01 0.015 0.02 0.03 0.04 0.05 0.06 0.08 0.1 0.15 0.2 0.3 0.4 0.5 0.6
    0.8 1 1.5 2 3 4 5 6 8 10
DF0 LOG 2.78E-6 1.11E-6 5.88E-7 2.56E-7 1.56E-7 1.2E-7 1.11E-7 1.2E-7 1.47E-7
    2.38E-7 3.45E-7 5.56E-7 7.69E-7 9.09E-7 1.14E-6 1.47E-6 1.79E-6 2.44E-6
    3.03E-6 4E-6 4.76E-6 5.56E-6 6.25E-6 7.69E-6 9.09E-6
C
nps 1000000000 $ 1000000000 photons to count
C
print 10 30 32 40 90
C
C
C MATERIAL CARDS
m1 12000.04p 0.00174 &
    26000.04p 0.05936 &
    24000.04p 0.01743 &
    28000.04p 0.00772 $ the pipe & sleeve material:SS 304 RHO= 7.92 g/cc
m2 6000.04p 0.001062688 &
    29000.04p 0.000148783 &

```

26000.04p 0.082956838 &  
25000.04p 0.000980939 &  
15000.04p 6.10487E-5 &  
14000.04p 0.000500973 &  
16000.04p 7.37139E-5 \$ shield: A36 steel RHO = 7.85g/cc  
m3 7014.04p -0.755636 &  
8016.04p -0.231475 &  
18000.04p -0.012889 \$ air (US S. Atm at sea level) density 0.0012 g/cc  
m4 24000.04p -0.003500 &  
29000.04p -0.004000 &  
26000.04p -0.007000 &  
12000.04p -0.012000 &  
25000.04p -0.001500 &  
14000.04p -0.008000 &  
22000.04p -0.001500 &  
30000.04p -0.002500 &  
13000.04p -0.960000 \$ Al-6061 Matweb (max Wt% for non-Al) RHO=2.7 g/cc

**APPENDIX B.**  
**LIST OF MAJOR COMPONENTS**

### List of Major Components

<b>Product</b>	<b>Manufacture</b>	<b>Model Number</b>
12VDC 4 unit relay board	Winford Engineering	RLP104-12V-FT
2 port 3/4" NPT manifold	A1 Manifolds	MS1402-90*
24"x24" by 0.354" thick cast acrylic sheets	McMaster-Carr	8560K603
3 port 3/4" NPT manifold	A1 Manifolds	MS1403-90*
3-way N.C. 3/4" NPT valve	Parker Hannifin Corp.	73312
Aluminum 6061-T6 piping	onlinemetals.com	1" NPT sch. 80
Aluminum 6061-T6 tubing	onlinemetals.com	1.055" ID X 1.125"OD
Aluminum 6061-T6 tubing	onlinemetals.com	0.5" ID X 0.755"OD
Aluminum 6061-T6 plate	onlinemetals.com	1'X1' by 1/2" thick
Aluminum 6061-T6 plate	onlinemetals.com	1'X1' by 1/4" thick
Aluminum 6061-T6 stock	onlinemetals.com	3" OD by 1' long
Audio cable 18AWG 4 conductor	McMaster-Carr	71055K77
Cast Aluminum Heavy Duty Blower 90CFM	McMaster-Carr	1954K51
Counting Shield	Gamma Products Inc.	G-16-S
Counting Shield	Gamma Products Inc.	G4U-2
Electric 1" 12VDC ball valve	KZCO Valves	92FM23-10D20-P01
Electronic valve switch box	KZCO Valves	EHSX-26A
HEPA filter 8"x8" by 5-7/8" thick	McMaster-Carr	5612T27
Leaded acrylic viewing shield 1.5 mm Pb eq.	Direct Scientific	DS-PBA-15AA-15
Lynx Digital Signal Analyzer	Canberra	Lynx
Manual 1" NPT Ball Valve 316 S.S.	McMaster-Carr	4632K145
Miniature polyethylene vials	Cole-Parmer	EP191LG-PE
Nylon braided PVC tubing 1-1/4" ID 1-3/4" OD	McMaster-Carr	5238K798
Nylon braided PVC tubing 3/4" ID 1-1/8" OD	McMaster-Carr	5238K768
Poptop HPGe Detector	Ortec	GEM10P4-70Plus
Programmable Control	Anaheim Automation Inc.	DPY50601
RS-232 to RS-485 PC converter	Anaheim Automation Inc.	485SD9TB
316 Stainless Steel Stock	onlinemetals.com	3" OD by 1' long
Stepper Motor	Lin Engineering	8718L-02S-01R0

## VITA

Edwin Joseph Grant was born April 17, 1986, in St. Louis, Missouri. He became interested in Nuclear Engineering while taking classes at East Central College, in Union, Missouri. Edwin then transferred into the Nuclear Engineering Program at Missouri University of Science and Technology, and graduated with a B.S. in Nuclear Engineering, with Magna Cum Laude honors, in May 2009. He continued his M.S. studies, in Nuclear Engineering at Missouri S&T, and will graduate in the fall semester of 2010. Mr. Grant plans on starting his Ph.D. work on the Missouri S&T campus until completed.

Edwin joined the American Nuclear Society both as a student and a national member. Also, Edwin was induced into Alpha Nu Sigma, the in the 2009 academic year.

