

---

Masters Theses

Student Theses and Dissertations

---

1971

## The integrated planning method of project planning, development and implementation

Joseph Frank Lynch

Follow this and additional works at: [https://scholarsmine.mst.edu/masters\\_theses](https://scholarsmine.mst.edu/masters_theses)



Part of the [Civil and Environmental Engineering Commons](#)

Department:

---

### Recommended Citation

Lynch, Joseph Frank, "The integrated planning method of project planning, development and implementation" (1971). *Masters Theses*. 5489.

[https://scholarsmine.mst.edu/masters\\_theses/5489](https://scholarsmine.mst.edu/masters_theses/5489)

This thesis is brought to you by Scholars' Mine, a service of the Missouri S&T Library and Learning Resources. This work is protected by U. S. Copyright Law. Unauthorized use including reproduction for redistribution requires the permission of the copyright holder. For more information, please contact [scholarsmine@mst.edu](mailto:scholarsmine@mst.edu).

THE INTEGRATED PLANNING METHOD  
OF PROJECT PLANNING, DEVELOPMENT AND IMPLEMENTATION

BY

JOSEPH FRANK LYNCH, 1946-

A THESIS

Presented to the Faculty of the Graduate School of the

UNIVERSITY OF MISSOURI-ROLLA

In Partial Fulfillment of the Requirements for the Degree

MASTER OF SCIENCE IN  
ENVIRONMENTAL AND PLANNING ENGINEERING

1971

Approved by

Lawrence H. Sieck (Advisor) James L. Joray  
Henry A. Wiebe

## ABSTRACT

Present comprehensive planning endeavors lack a consistent methodology which will produce realistic, useable results. The validity of this statement should be obvious after one has read Miller's "Evaluation of City and Region Planning Techniques."

This paper contains a methodology, "The Integrated Planning Method," which will go a long way toward correcting this gross inadequacy that planners presently encounter in directing planning efforts.

Two government developed planning and analysis procedures that, up until this time have been applied almost exclusively to hardware systems, have been combined into one integrated planning methodology that will provide not only meaningful and rigorous definition and analysis of any problem faced by the planner but a path to a solution that, if followed, will produce a complete system for planning and implementation.

Analysis of existing plans, planning methodologies and planning problems is to be the suggested use of the Value Analysis procedure that up to the present has only been used by the Department of Defense and industrial organizations to improve hardware systems. Phase Project Planning as developed by the National Aeronautics and Space Administration for use in planning for space hardware systems and their supporting personnel and equipment will be the

suggested method for developing the desired plans. Each, in the past has been utilized separately. This report lays out a method of combining them into an Integrated Planning Method which will be applicable to all planning efforts.

## ACKNOWLEDGEMENT

The author would like to extend his appreciation to his advisor Dr. Lawrence Sieck for his guidance and counsel throughout graduate school and particularly for his assistance in completion of this thesis. Thanks also to Dr. Gordon Weiss and Mr. Charles Miller for their many ideas and much assistance in this effort for without their help this work would not have been possible.

Lastly, the author would like to acknowledge the excellent typing assistance of Mrs. Alice Crangle and not least of all the friendship of the many members of the Wesley Foundation whose support and encouragement during the entire effort was much appreciated.

## TABLE OF CONTENTS

	Page
ABSTRACT.....	ii
ACKNOWLEDGEMENT.....	iv
TABLE OF CONTENTS.....	v
I. INTRODUCTION.....	1
A. Importance to Society.....	1
1. Why Planning.....	1
2. What is Planning.....	2
B. The Problem and Proposed Solution by the "Integrated Planning Method" (IPM).....	4
II. DISCUSSION.....	5
A. Description of the IPM System.....	5
1. Total Systems Concept as Applied to IPM.....	5
2. Goals and Objectives of IPM.....	6
B. Development of the Planning Methodology of IPM.....	8
1. Value Analysis.....	8
a. Information Step.....	8
b. Speculative Step.....	10
c. Analytical Step.....	10
d. Objectives of Value Analysis.....	11
2. Phased Project Planning (PPP).....	11
a. The Total Systems Structure of PPP	13
b. Preliminary Analysis-Phase-A.....	16
c. Definition-Phase-B.....	18

	Page
d. Design-Phase-C.....	21
e. Development/Implementation-Phase D.	23
3. Information, Documentation and Control.	24
C. Application of IPM.....	25
III. CONCLUSIONS.....	33
IV. RECOMMENDATIONS.....	34
BIBLIOGRAPHY.....	35
VITA.....	36
APPENDIX A - Integrated Planning Method Worksheets.....	37

## I. INTRODUCTION

### A. Importance to Society

The philosopher Spinoza once said, "our job as men of knowledge is not to weep or laugh but to understand."<sup>1</sup>(p. 7) This quotation captures what ought to be the essence of present-day planning efforts. Understanding the reason for needed changes in society, and planning for these changes is certainly a more positive approach than to commiserate over present conditions, or to weep or to laugh about the future consequences of present actions; worse yet is taking advantage of the need for planning by giving it lip service and taking the taxpayer's money and returning plans that cannot be implemented or ones that treat only the symptoms.

#### 1. Why Planning

But first this question; why plan at all? Change will take care of itself. Or, the other side of the coin turns up Marxian intervention, pure socialism. As stated by Bennis, Benne and Chin in their book The Planning of Change<sup>1</sup>(p. 2)

"Concerning the methods of change we can observe two idea systems in the contemporary scene that are directly counterposed: the law of nonintervention and the law of radical intervention...Planned change, as we view it, emerges as the only feasible alternative to these methods; that is, a method which self-consciously and experimentally employs social technology to help solve the problem of men and societies."

Thus, accepting that change will occur, not providing for this change (witness the large American cities) is as



undesirable as radical intervention (Russian communism for example). The debate really has shifted from an ideological "should we seek to plan change" to a technical one of "how to plan particular changes," then there is a tremendous need for effective planning of this inevitable change.<sup>2</sup>(p. 41)

## 2. What is Planning

In light of this concept of change, then, one might see planning as defined by Johnson, Kast and Rosenzweig in The Theory and Management of Systems. "Planning is the process by which the system adapts its resources to changing environmental and internal forces," or Planning is "intelligent cooperation with the inevitable."<sup>3</sup>(p. 21) The importance of cooperating with these inevitable changing forces is only hinted at here. But David Ewing in his book The Practice of Planning says "Indeed, to understand planning is to understand a process which, as much as or more than any other resource of capability, gives the modern corporation its unique ability to prosper in a world of continuing change."<sup>4</sup>(p. 7) Or again from Johnson, Kast and Rosenzweig "As the industrial, social and political environments grow more and more complex, greater emphasis is placed upon planning as a means of coping with the uncertainty of the future...Rapidly advancing technology has also emphasized the need for planning."<sup>3</sup>(p. 22) And further, "It [planning] is a dynamic function and must be carried out effectively

in order to provide a solid foundation for the remaining managerial activities."<sup>3</sup>(p. 21)

All of these statements would seem to justify the expenditure of much effort in the practice of planning; true, much effort has been applied, but few solutions to the problems confronted in planning efforts seem to be forthcoming.<sup>5</sup>(p. 2) What is the reason for this? To gain some insight into the question of certain failures of planning, an example of what planning does and does not entail, might well be in order. Planning is not unrealistic attempts at forecasting; it is not extensive budgeting; it is not complete elimination of risk in decision making; it is not just good communication, coordination and public relations work; it is not a study effort directed at improving operating efficiency; and most of all it is not mere maintenance of a beaucratic planning department for writing reports.<sup>4</sup>(p. 16) Good planning includes varying degrees of each of these characteristics plus one other important element. That element, found by Miller upon examining the content and results of some 10 planning efforts, is the need for realistic goals and objectives and appropriate management procedures in attaining them.<sup>5</sup>(p. 86)

If one continues the line of thought suggested by Miller's recommendations, it would seem to imply the development of a formalized planning technique that might help prevent some of the pitfalls that have plagued present

planning efforts.

B. The Problem and Proposed Solution by the "Integrated Planning Method" (IPM)

It is the intent of this thesis to develop a formalized and useable planning methodology that will in some measure come a step closer to producing planning efforts devoid of such inadequacies as those pointed out by Miller in his "Evaluation of City and Region Planning Techniques."

This methodology will consist of the "Value Analysis Technique" of problem identification as proposed by Miller<sup>5</sup>(p. 86) and the "Phased Project Planning" project development procedure as developed by NASA<sup>6</sup> combined under the concept of "Total Systems." The result is a system that will be known as "The Integrated Planning Method" for Development of Planning Projects.

## II. DISCUSSION

### A. Description of the IPM System

#### 1. Total System Concept as Applied to IPM

The foundation of the "Total System Concept" is a principle that has as its origin a change in the frame of reference of some scientists from a dissection of minute areas of interest to a consideration of the whole.<sup>3</sup>(p. 5)

In "The Nature of the Physical World" Eddington states,<sup>7</sup>(p. 104)

"From the point of view of the philosophy of science the conception associated with entropy must, I think, be ranked as the great contribution of the 19th century to scientific thought. It marked a reaction from the view that everything to which science need pay attention is discovered by microscopic dissection of objects. It provided an alternative standpoint in which the center of interest is shifted from the entities reached by the customary analysis (atoms, electric potentials, etc.) to qualities possessed by the stream as a whole, which cannot be split up and located-a little bit here and a little bit there...We often think that when we have completed our study of one we know all about two because 'two' is 'one and one'. We forget that we still have to make a study of 'and'."

This subtle change in attitude was the beginning of that new line of thought that had as its result the "Total Systems Concept" as we now know it. This is demonstrated in the following statement by Culliton made in Harvard Business Review: "...My thesis, then, is that quietly, necessarily, and inevitably we are entering a period that forces man to find more accurate answers to questions involving the 'wholeness' of an operation, and that demands entirely new

approaches to these questions."<sup>8</sup>(p. 38)

This concept of the importance of interrelationships and organizations as they relate to the entire system is the method by which planned change can be best understood and accomplished. As stated by Johnson, Kast and Rosenzweig, "Under the systems concept the planning process can be considered as the vehicle for accomplishment of systems change,"<sup>3</sup>(p. 25) and "with a more dynamic environment and large, complex units operating in the face of many forces restricting flexibility, the planning function becomes critical and must be thought of on a total-systems basis. Since the consequences of any decision have such a broad and drastic impact, management through its planning function, must try for the optimal course of action."<sup>3</sup>(p. 23)

The planning of a project which has complex components and interfaces with broad implications for its environment should be done, then, only on a total systems basis. The system that is about to be described is a methodology that will provide for the consequences of all its subsystems and interrelationships. It consists of the following elements: a problem identification phase, a phase planning for project development, an information system, and a project management control system.

## 2. Goals and Objectives of IPM

The comprehensive nature of this system will be such that its scope of application will be almost limitless. It

is intended to be useful in developing the small planning project as well as in planning projects that have a span from feasibility to implementation, operation and maintenance. But it is particularly valuable concerning projects that will require significant resources and funding levels and projects that require formation of important relationships with external organizations and agencies.

In addition to achieving the goals of total system comprehensiveness and broad application possibilities, this system wishes to establish a solid foundation in initial information gathering as a necessary prerequisite for problem identification. Next, it will provide for adequate problem identification including appropriate goal and objective setting. This combination of information, problem identification and goal and objective setting is probably the most important and also the most glossed-over area of present planning efforts. If this phase of planning is not correct then the remainder of the planning effort may be entirely misdirected.

Provision for useful feedback and change mechanisms during the actual planning effort is also a goal that this system will help to realize. The attempt here is at building in flexibility, and in a world of rapidly changing technology this is a planning principal that can no longer be afforded only lip service.

## B. Development of the Planning Methodology of IPM

### 1. Value Analysis

Value analysis<sup>9</sup> is a procedure used by industrial engineers particularly in the Department of Defense to functionally evaluate products and procedures and processes for making products. Its approach is to carefully determine the basic function of the component or process under question and then to assign a use value to that basic function. The object then is to specify the use value at the desired level and to reduce the cost value to a minimum that will still maintain that use value level.<sup>5(p. 21)</sup> It is proposed that this process be modified and used as the problem identification phase of the planning methodology and also to establish the basic direction that the planning effort will take. (The defining of the basic function and specifying the use value level is analogous to problem identification and goal setting, and the reduction of cost value is comparable to objective setting and establishing of the most feasible project approach.)

#### a. Information Step

The initial step in any planning effort is the gathering of information since it is this information upon which the remainder of the study will be based. Regardless of the information, the degree of reliability of the source must be known. A plan based on questionable information is worse than a plan based on no information. The information phase should include:

(1) Any and all information that might possibly have a bearing on past or present systems used in the defined study area. Of special interest here is any information pertaining to inadequacies of the present system, maintenance, operation and cost of all types and pertinent social, political, psychological attitudes and related facts.

(2) Data on similar systems that exist elsewhere and any proposed systems.

(3) What is the existing system achieving, if anything, and towards what goal is it aimed?

(4) Evaluate these goals by use value and cost value. This is similar to a Benefit/Cost analysis but should include social, environmental, and psychological costs and benefits as well as any that might be incurred by technological change.

(5) Define and evaluate the existing objectives according to their basic function. This involves specifying exactly what is presently being done toward accomplishing existing goals. This should include specifying cost objectives as well as environmental and social objectives etc.

(6) Propose goals for the new system and compare them to the old goals. This is the basic problem identification step in which goals are suggested that will overcome the inadequacies of the existing system.

(7) Propose objectives for the new system. These objectives will be the specifications necessary for goal



achievement. These also will be functionally evaluated to make sure that they are necessary for goal achievement.

These two final steps in the information phase serve to delineate the problem toward which the remaining planning effort is to be directed. The rest of the value analysis portion of the planning system is aimed at consideration of all conceivable approaches toward satisfaction of the stated objectives and selection of the most promising of these to be used as a starting place for the phased planning portion of the project.

b. Speculative Step

The important thing to remember about the speculative step is that it involves no analysis. Any manner of speculation can be used to generate alternative approaches aimed at satisfying the stated objectives. No suggestion is to be limited because of feasibility. To generate ideas any combination of the following can be a catalyst: Creating, Innovating, Transposing, Eliminating, and Combining. Different directions of approach should also include psychological, social, political or management points of view in addition to standard technical hardware and procedure variations.

c. Analytical Step

The Analytical Step requires that an initial selection of the most promising ideas be made from those generated in the speculative step. This is designed to eliminate the

obviously unfeasible approaches.

The resulting ideas will then warrant further investigation in the form of:

- (1) Gross Cost/Benefit estimates for each alternative.
- (2) Variable and fixed cost breakdowns for each alternative.
- (3) Gross Implementation, maintenance and operating costs for each alternative.
- (4) Advantages and disadvantages of each alternative to include social, environmental and political implications.
- (5) Any other considerations that cannot be costed.

Carefully compare the alternatives and select the approach or approaches with the least probable cost that will still satisfy the specified objective.

#### d. Objectives of Value Analysis

The emphasis of the Value Analysis, then, is adequate problem identification and objective setting that will provide a basis for establishing a probable project direction. This direction will be the focus on the starting place for the in-depth phased planning of the project. And again, it must be realized that if this portion of the system is not based on reliable information and carried out adequately, then the succeeding effort is a waste of time.<sup>10</sup>(p. 6)

## 2. Phased Project Planning (PPP)

PPP as developed by NASA<sup>6</sup> is much more than a phased outline for planning. It is actually a philosophy for

project planning and management. In the IPM System it will serve as the organizing structure around which the plan for the planning project and management of the planning project is built. Its focus is the planning and definition phase that should precede full scale development of the project. This point of focus is derived from the contention that project planning techniques should be structured using sufficient feedback, flexibility and control and if so structured and followed in action as well as in principal, that the succeeding project development and implementation will come naturally.

PPP was originally developed by NASA to help cope with projects involving a high degree of risk and uncertainty that comes with advanced technology such as that used in space hardware systems. Built-in flexibility also provides for unforeseen problems, changes, and rapid technological developments. It is hoped that PPP's ability to increase the probability of achieving specified performance from its hardware systems using initially allocated time and resources will also help the planner to tremendously increase the flexibility of his planning efforts and still meet his objectives with a minimum of resources and time.

From the "total systems" point of view, phased planning is structured to provide a progressive build up of knowledge as each phase is completed. When this is done in regard to all aspects of the project it results in an understanding

of the total system that will greatly enhance implementation and total project benefit.

The most important capability that PPP provides is the combining of all the above features into a disciplined basis for effective project management. Disciplined management can be attributed to the characteristics of PPP that allow it to:

- (1) evaluate efforts at critical points
- (2) be aware of future options and provide the capacity to use them effectively
- (3) optimize results according to total project objective relationships to other activities.<sup>6</sup>(p. 2-1)

a. The Total Systems Structure of PPP

Phased Planning is structured to foster a natural yet controlled evolution and management of the desired planning effort. This will help to insure that nothing is overlooked in either the management of resources, time and related programs used in developing the plan or in the plan itself. This control is affected by deliniating the content of four separate planning phases and preceding each phase with a major decision point at which the planning effort, both past and future is critically evaluated. (See Appendix A)

The first decision point immediately follows the Value Analysis phase of the planning effort. Here, it is decided whether or not to initiate a feasibility study, on a total system basis, of the approach or approaches selected in the

analytical step of the Value Analysis.

Phase-A is called the Preliminary Analysis. Its purpose is to analyze overall project approaches that were said to warrant further investigation by the value analysis. It will identify such project elements as major facilities that will require development, necessary operational and logistical support and additional research efforts to make the approach feasible. Finally, it will make a further determination of the feasibility of both approaches under consideration and of the objectives as specified in the Value analysis.

The second decision point at the end of Phase-A involves evaluation of project feasibility at this point in time and can terminate or continue determination of final approach feasibility.

Phase-B includes detailed study, preliminary design and comparison of all approaches still under consideration. Of particular importance here is comparative economic, social, environmental, and political, impacts of the approaches. The primary function of this phase is to finally resolve these relative questions and to choose a single project approach.

Based on completed impact and feasibility studies and preliminary engineering analysis the third decision will now be made to either terminate development, or to start the design and the detailed definition of the plan.

This action is followed by implementation of Phase-C of the planning effort. It includes finalization and detailing of planning objectives and careful definition of the proposed solution that is to be developed. Design and testing of system elements whose technological development is critical to final design and establishment of realistic scheduled and resource requirements for Phase-D contract negotiations is also a part of this phase. An additional requirement of Phase-C is identification of essential back-up systems and alternate facilities, logistics and any other support operation that might require redundancy.

Compatibility of the planning objectives and the proposed development plan is the criteria used in making the fourth decision to move to Phase-D.

Phase-D will complete the design, implementation and operation plan and will manage actual implementation. This phase will also include development of any management and control techniques that will be needed in plan implementation.

There are several elements common to all planning phases of IPM. Initially, the scope of each phase needs to be carefully outlined. This is followed by setting objectives for the phase concerned. Next, a work plan for each particular phase is submitted. It should include the following:

- (1) Assignment of all work responsibilities such as in-house, other agencies, or contract etc.

(2) Definite schedule and resource requirements needed to complete this phase of the planning effort.

(3) Establishment of a management structure that will require definition and implementation of control and reporting techniques.

(4) Definition and maintenance of relationships to all future phases. Finally, each phase should make provisions for research, technology, logistics, operational, political or other external support that may be essential for present phase or ultimate project implementation.

b. Preliminary Analysis-Phase-A

The objectives of this planning phase are (1) to further analyze and identify from the results of the value analysis, those concepts worthy of detailed investigation and (2) to supply management with the information needed to further determine feasibility of project approaches and objectives such that the decision can be made concerning the nature of follow-on activities.

The Content of the Preliminary Analysis study effort should include consideration and complete coverage of the following elements for each approach being considered.

(1) Further detailed development of planning objectives including the feasibility of achieving these objectives under this project approach.

(2) Identification of all supporting requirements including political, social, financial, logistic as well as

research and technology.

(3) Major proposed changes in existing systems that would be required if this approach to the problem solution were adopted. This will include both deletion and addition of systems elements plus plans for project implementation including construction, operation, and maintenance.

(4) Determination of a gross implementation schedule.

(5) Estimates of gross resource requirements including funding sources and amounts, manpower needs and facilities.

(6) Economic, environmental, social-psychological, technological and political impact studies deliniating both advantages and disadvantages of the specific approach.

(7) Trade-off analysis in relation to important planning objectives in an effort to determine the feasibility of achieving optimum compatability with these objectives.

(8) Definition and planning of relationships to follow-on and other related projects,

The result of this Phase-A study effort will be an analytical report on which the recommendations and decisions for follow-on activities will be based. It should include:

(1) How the objectives of each particular approach will satisfy the total planning objectives defined in the Value Analysis.

(2) Preliminary specifications for use in Phase-B as derived from planning objectives.

(3) Presentation of all information available on each approach.



(4) Comprehensive comparative analysis of alternatives and trade-off, particularly resource and scheduling trade-offs.

(5) Identification of separate study efforts that will be required in Phase-B.

(6) Impact statement in all relevant areas (economic, social-psychological, environmental, political, technological etc.)

(7) Identification and planning for research projects critical to design and development.

(8) Relationships to follow-on activities and other projects.

(9) Conclusions as to the feasibility of specific approaches satisfying the planning objectives.

(10) Recommendations.

(11) If continuing into Phase-B is recommended, a preliminary draft plan for this phase should be developed for submission to the proper decision making authority.

c. Definition-Phase-B

The objective of Phase-B, definition, is to obtain enough information through preliminary design and extensive comparative and trade-off analyses to permit recommendation of a single approach for satisfying the planning objectives.

It involves separate detailed study efforts covering each project approach still under consideration. These may be either in-house or contract efforts depending on project

size and complexity and should fulfill all of the following study requirements.

- (1) Further refinement of project approach.
- (2) Determination of preliminary system design data including specifications.
- (3) Preliminary assessment of construction, testing, maintenance and operating techniques.
- (4) Definition of implementation and operational support requirements, particularly political and social support.
- (5) Identification of systems design margins, safety factors, and determination of reliability and quality.
- (6) Further consideration and detailing of economic, environmental, social, psychological and political impact.
- (7) Preliminary plan for dealing with social and political problems that might appear after implementation.
- (8) Identification of advanced research and technology development requirements necessary to solve project development problems with state-of-the-art technology. Examples would include research directed toward construction, inspection, and maintenance techniques, and solutions to environmental and social problems.
- (9) Total project management plan.
- (10) Contractor management plan.
- (11) Data management plan.
- (12) Estimated schedule for project implementation supported by Program Evaluation and Review Technique.<sup>11</sup>(p. 470)

(13) Contractor procurement planning for Phases C and D.

(14) More detailed estimate of resource requirements.

(15) More detailed trade-off analysis in relation to planning objectives.

A report containing all pertinent information, conclusions and recommendations will be submitted on each study effort.

From these requirements an analytical report for Phase-B will be drawn up and submitted to the proper decision making authority. It will include:

(1) Complete information, including specifications, on each approach.

(2) Comprehensive comparative and trade-off analyses of all approaches.

(3) Identification of the most desirable approach for further planning and implementation.

(4) Find feasibility determination of the project approach, i.e. will it satisfy planning objectives?

(5) Identification of critical advanced technology and development areas in the event of follow-on activities.

This report is the basis for the decision to continue or terminate the project. Its accuracy cannot be over emphasized. A plan for Phase-C should also be included in this report providing that Phase-C is recommended.

d. Design-Phase-C

Phase-C objectives are directed toward finalizing planning objectives and complete definition and design of the proposed solution selected in Phase-B. They also will provide the necessary information on which to base the decision for final planning efforts and implementation in Phase-D. This phase also includes provisions to insure that Phase-D technology will be state-of-the-art, that schedule and resource requirements for Phase-D are realistic and that specifications are sufficient for Phase-D contract negotiations.

The planning agency (in-house or contracted) that undertakes a Phase-C design effort must realize that the result not only must fulfill the planning objectives but it must be sold to those who hold the power to implement it. (The governmental authority or the voter or both) One result is useless without the other. The Phase-C effort should provide the following:

- (1) Detailed description of the total system including the design and sales effort.
- (2) Technical analysis of the integrated system from both the engineering and social sciences aspect. This will assure compatibility within the system and complete establishment of interface requirements.
- (3) Identification of significant end items such as hardware, facilities, services, data and other benefits

(social, environmental etc.)

(4) Preliminary engineering design, architectural design, social and human design.

(5) Preliminary design of supporting systems (engineering or otherwise) and identification of implementation, test, evaluation, maintenance and operational facilities.

(6) Identification of plan for back-up subsystems development.

(7) Preparation of final contractor specifications.

(8) Preparation of other end-item specifications (hardware, services etc.)

(9) Plans for development, management, facilities, man-power, logistics, construction, tests, maintenance, operation and evaluation.

Each Phase-C planning agency or contractor will submit:

(1) A report on the design study effort including recommended systems, subsystems and back-up systems design and specifications and bases for these recommendations such as comparisons and trade-offs considered, negative design attempts and test data.

(2) A proposal for selling of the implementation phase which will also include complete implementation plans as well as basic technical and support plans as described in the Phase-C study effort. Additional requirements are Program Evaluation and Review Technique scheduling and yearly cost projections.

The contacting agency will then decide on implementation or termination depending on the result of sales efforts and other conclusions and recommendations contained in a final in-house analytical report concerning Phase-C.

It should be noted at this point that the progressive project evolution, refinement, knowledge build-up and constant evaluation and re-evaluation has resulted in a detailed work plan that will greatly aid project implementation. This is one of the main objectives of PPP as it was originally devised.<sup>6</sup>(p. A-1)

e. Development/Implementation-Phase-D

Phase D is composed of implementation plan development and finalization and implementation within resource and schedule estimates and with optimal compatibility in relation to original planning objectives.

The content of the development/implementation plan can be broken down into three major areas - the Technical Plan, the Management Plan and the Procurement Plan.

(1) The Technical Plan will include all development, construction and implementation procedures deemed necessary for final implementation of Phase-C systems and subsystems. This will be done according to design and performance parameters and specifications of Phase-C. This will include all supporting systems such as maintenance and operation.

(2) The Management Plan consists of a total organizational effort including control of all information,

documentation, reviewing and reporting, testing and evaluation, and the personnel required to make them effective. This varies from project to project but includes such techniques as budgeting, regular progress and status reports etc. This should be done according to specific task breakdowns.

(3) The Procurement Plan would include procurement policies, schedules, and contract breakdowns. Further information on procurement aspects of PPP is available in the appendix to NASA's Phase Project Planning Manual.<sup>6</sup>(p. A-8) This plan will also include provisions for any special implementation considerations deemed necessary by phase impact studies.

### 3. Information, Documentation and Control

A planning project utilizing the IPM approach cannot even be properly initiated without an adequate information system. And results of any significance at all will not be forthcoming from a project that does not have appropriate documentation and control systems. The entire IPM system is based on the build up of reliable information and knowledge through forced reporting, reviewing and constant re-evaluation. The system, if truly followed, is in itself an adequate information, documentation and control system. It need only be said that the techniques required to satisfy these objectives vary with the scope and application of the planning project under consideration.

### C. Application of IPM

This section contains a brief demonstration which shows how the various phases of IPM might be applied. Miller<sup>5</sup>(p. 76) conducted a Value Analysis on a planning effort published by the City of Minneapolis Planning Commission in 1960 entitled Minneapolis in the Motor Age, Major Street Planning Goals. This plan outlined Common Objectives for the major street system.<sup>12</sup>(p. 23) For purposes of demonstration it will be assumed that these objectives are an adequate problem identification similar to the objective setting that is provided in the Value Analysis Information Step. The following, then, is an illustration as to how IPM might be applied in satisfying these objectives.

#### Value Analysis-Information Step:

The balance of the information step might be carried out by delineating what information should be gathered concerning separate objectives such that each could be adequately considered in developing possible alternatives.

The following is such an attempt:

Objective 1. The project should be planned and improved according to scientifically projected traffic needs.

a. The population growth potential for Minneapolis should be examined and projections made.

b. Technological improvements and trends should be analyzed in regard to the potential change in automobile use.



c. The possible legal framework must be examined in order to project the affect of proposed ordinances and rulings upon automobile use.

d. The economic factors involved in automobile ownership must be examined in order to determine how the rate of auto ownership will change.

Objective 2. The project routes should be classified and designed according to their function, i.e. long or short distance travel, fast or slow movement, etc.

a. Origin destination studies are necessary to determine routes of travel and destination.

b. The effects of traffic generating facilities must be examined and quantified.

c. Zoning ordinances must be studied to determine their effect on location of traffic generators.

d. Industrial and business growth potential must be examined in the preparation of route classifications in order to maintain their accuracy over reasonable periods of time.

Objective 3. Project Planning should go hand in hand with land use planning.

a. The zoning ordinances must be studied to control the haphazard use of land. This will enable the systematic and orderly progression of land use.

b. The Industrial, Business, and housing growth potential must be examined in the preparation of controlled

land use plans. This will minimize the assault on the environment and human sensitivity.

Objective 4. The project should help to preserve residential communities and neighborhoods as well as business and industrial districts.

a. Sociological classification of neighborhoods should be carried out so that boundaries can be established.

b. The economic trading boundaries of shopping centers and neighborhood businesses must be established.

c. Major industrial employers and worker populations must be examined in order not to cut off a segment of employees from their work.

Objective 5. The project should be integrated with other transportation networks - water, rail and air.

a. The present location and use of these facilities must be determined.

b. Trends of expansion or decline of these transportation systems must be determined on a national as well as a local basis.

c. Expansions, relocations or termination of facility use must be obtained.

Objective 6. The project should be planned to facilitate transit flow (bus and other mass transportation tools).

a. Local and proposed bus and other public transportation routes must be located.

b. Plans for new mass transportation facilities must be obtained and their possible routes evaluated in the light

of the existing and proposed highway transportation network.

Objective 7. The project should work in complete harmony with the remaining streets to form an integrated network.

a. The existing street system must be functionally evaluated to prevent cutting other thoroughfares and flooding residential streets with traffic.

b. The potential use of the present street network must be delineated street by street.

Value Analysis-Speculative Step:

This information could then be used to speculate on possible alternative approaches to developing or improving the major street system.

Value Analysis-Analytical Step:

This step will serve to select the most promising approaches from those created in the speculative step. For the purpose of demonstration, the assumption can be made that by very gross costs estimates and preliminary consideration of gross advantages and disadvantages the following the approaches have been selected for possible evaluation in the Preliminary Analysis Phase-A. They are:

1. The construction of a new crosstown limited across freeway.

2. The use of the existing street systems without any change at all.

3. The modification of an existing major thoroughfare into an expressway which connects with Interstate 35.

### First Decision Point

The decision might then be made to initiate Phase-A to terminate follow-on activities.

### Phase-A-Preliminary Analysis:

In this phase the three approaches chosen in Value Analysis are further analyzed using more detailed cost data and more thorough considerations of impact in all areas of interest. This might result in a list of advantages and disadvantages for each approach similar to these:

1. The construction of an all new cross town limited access freeway which would bisect the city and connect with interstate highway 35.

#### Advantages:

- a. High traffic volumes.
- b. High continuous travel speeds.
- c. Accident rate cut by 2/3 over expressway.
- d. Continuity of traffic flow.

#### Disadvantages:

- a. Very high expense.
- b. Requires condemning and razing of property along the routes.
- c. Requires extensive acquisition of new right of ways.
- d. Requires grade separation at all intersections.
- e. Requires large land areas for interchanges.
- f. Disrupts and divides neighborhoods.

2. The use of the existing street network with very little change.

Advantages:

- a. No disruption of neighborhoods.
- b. Low Cost, requiring very minor construction, and right-of-way acquisition.

Disadvantages:

- a. Street overloading with increasing volumes.
  - b. Slow speed.
  - c. Discontinuity of flow.
  - d. High accident rates.
3. The modification of an existing major thoroughfare into an expressway which would connect with Interstate 35.

Advantages:

- a. Moderate cost.
- b. Higher volumes than existing streets.
- c. Higher short distance speeds than with existing streets.

Disadvantages:

- a. Very high accident rate.
- b. Discontinuity of flow.
- c. Easily overloaded.

The advantages and disadvantages of each approach would be used to assess the feasibility of satisfying the objectives as stated in the Value Analysis. It might be recommended that the second alternative approach of no new construction would not meet these objectives but the remaining two

might.

### Second Decision Point

The second decision point is then reached. It is decided to continue into Phase-B and initiate a final feasibility study comparing the two remaining approaches.

#### Phase-B-Definition:

Phase-B would include a systems analysis of each approach which would require development of preliminary design and specifications for both the freeway and expressway, definition of support elements and management plans for each, and final detailed impact studies (social, economic and political). A comparative and trade-off analysis would be conducted and the most feasible approach would be recommended. The freeway approach might be the selection made.

### Third Decision Point

The decision must then be made to continue design and development of the freeway or to terminate follow-on activities. Assume that it is decided to continue with follow-on activities.

#### Phase-C-Design:

Phase-C would involve detailed design of the freeway and complete development of the sales/implementation plan. This includes a thorough technical analysis from the engineering and the social science aspect which will result in final engineering, architectural and social design. Additional requirements to be developed in Phase-C are final support and management plans and costs and schedule estimates.

A list of what this phase contains might look like this:

1. Final route selection.
2. Provisions for right-of-way acquisition.
3. Detailed engineering analysis and design.
4. Social analysis and design.
5. Complete planning in all supporting areas including coordination with existing street systems.
6. Complete schedule and costs estimates.
7. Plan for alternate routes and detours.
8. Complete management, implementation and sales plan.
9. Complete contract specification to be used in letting of bids.

#### Fourth Decision Point

The final decision concerning implementation is made at this point and depends to a large extent on the public hearing/sales effort.

#### Phase-D-Development/Implementation:

This phase will consist primarily of construction efforts by contractors, relocation efforts by appropriate authorities and maintenance and operation efforts by the concerned agency.

### III. CONCLUSIONS

The advantages of IPM are many. Of primary importance is its ability to fulfill the need for a "Plan for Planning." IPM is a completely formalized methodology for planning based on the "Total Systems" concept. It provides comprehensive directing and managing of the entire planning effort.

IPM accomplishes this by virtue of the following characteristics:

1. It places sufficient emphasis on a completely separate and distinct problem definition, goal and objective setting phase.

2. It provides a disciplined basis for management and continuous feedback and re-evaluation throughout the planning effort. This is affected by strategic placement of required decision points and distinct phasing of the project.

3. It produces a continuously more detailed build-up of knowledge and information that will be of invaluable assistance should the project be implemented.

4. Its framework is structured such that it will demand the use of adequate information, documentation and control systems. It also clearly shows where these efforts need to be emphasized.

5. It considers problems that may arise in the selling of the proposed project as well as ones that may arise after implementation.



#### IV. RECOMMENDATIONS

The only feasible way of dealing with the rapid change in our society today is to plan for that change. To do this, it is recommended that a planning methodology be employed at all levels of project planning (both public works and private consulting) and legislated, if necessary, at all governmental levels.

This methodology should satisfy the following objectives:

1. It must offer a formalized technique for problem identification through Value Analysis.
  2. It must provide much needed flexibility during the entire planning effort through appropriate decision and feedback mechanisms.
  3. It must recognize the need for adequate information, documentation and control systems.
  4. It must give adequate consideration to implementation problems.
  5. It must apply the "Total System" planning concept.
- The Integrated Planning Method is such a methodology.

## BIBLIOGRAPHY

1. Bennis, Warren G., Benne, and Chin, The Planning of Change, Holt, Rinehart and Winston, Inc. New York, New York, 1969.
2. Bennis, Warren G., Benne, and Chin, The Planning of Change, Holt, Rinehart and Winston, Inc., New York, New York, 1961.
3. Johnson, Richard A., Kast, and Rosenzweig, The Theory and Management of Systems, McGraw-Hill Book Company, New York, New York, 1963.
4. Ewing, David W., The Practice of Planning, Harper and Row Company, New York, New York, 1968.
5. Miller, Charles C., "Evaluation of City and Region Planning Techniques," thesis submitted to the faculty of the University of Missouri-Rolla, December, 1970, Rolla, Missouri.
6. National Aeronautics and Space Administration, Phased Project Planning Guidelines, Washington, D.C., 1968.
7. Eddington, Aurthur, The Nature of the Physical World, University of Michigan Press, Ann Arbor, Michigan, 1958.
8. Culliton, James W., "Age of Synthesis," Harvard Business Review, September-October, 1962.
9. Department of Defense, Joint Course, Value Engineering Analysis, Washington, D.C., 1969.
10. Weiss, Gordon E., No. 17, "Systems Analysis and Interdisciplinary Personnel Supplemented by Engineering Management Techniques," Seminar for Comprehensive Planning Interchange of Perspectives and Issues at St. Louis, Missouri, July 11, 1970, Ed. Lawrence K. Sieck, Rolla Extension Division, University of Missouri-Rolla, 1970.
11. Pomeroy, Richard W., Systems and Procedures, Prentice-Hall, Englewood Clifts, New Jersey, 1968.
12. City of Minneapolis Planning Commission, Minneapolis in the Motor Age, Major Street Planning Goals, Minneapolis, Minnesota, August, 1960.

## VITA

Joseph Frank Lynch was born on July 12, 1946, in Republic, Missouri. He received his primary education in Catonsville, Maryland and his secondary education in North Little Rock, Arkansas. He received his college education from the University of Missouri-Rolla, in Rolla, Missouri and a Bachelor of Science Degree in Civil Engineering from the same institution in January, 1969. He received his commission in the United States Army Reserve at that time and was granted an educational delay to enter graduate school at the University of Missouri-Rolla.

During his enrollment there he has held both a National Science Foundation Traineeship and a National Defense Education Act Fellowship.

APPENDIX A  
Integrated Planning Method Worksheets

Flow Diagram

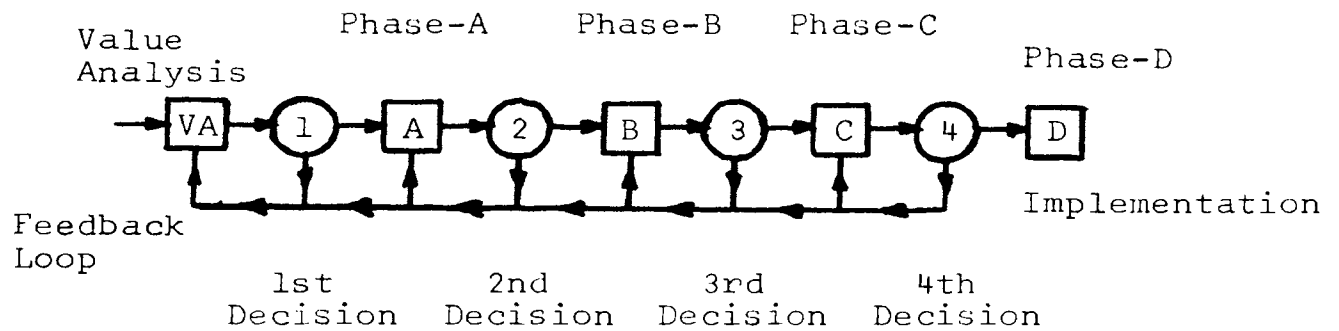

Value Analysis-Information Step

Purpose:

1. To gather and tabulate data concerning the present system.
2. To determine the project goals for the proposed system.
3. To evaluate these goals.
4. To set objectives that will accomplish these goals.

## Key Questions:

1. What are the goals of the present system?
2. What should be the goals of the New system?
3. What objectives will accomplish these new goals?
4. What does the present system cost?
5. What is it worth?

## Tests for Value:

1. Does the present system add value?
2. Is it directed toward its overall goal?
3. Does it need all of its subsystems to accomplish its goal?
4. Is its cost proportional to the value added?

## Techniques of Evaluation:

1. Evaluate the basic goals of the new system by comparison with goals of the present system.
2. Evaluate by objective functions that are necessary for direction toward goal accomplishment.
3. Evaluate by function.
4. Analyze cost of obtaining goals and objectives of the present system.

## A. Goal Identification:

Statement of Goal	Goal Priority



D. Function, Cost evaluation and Value added: list the objectives, their function, whether the function is basic or secondary, the present actual cost of the completed objective and the value added to the system by its completion. Assign a value to each objective using your past experience or by comparison with standard methods that provide a similar function.

Objective Number	Function	Value Added to Present System	Cost of Objectives Under Present System			
			Maint	Social	Total	Life Expectancy
↓	↓	↓	↓	↓	↓	↓

#### Information Step Checklist:

##### Specifications:

1. Are the goals realistic.
2. Are all objectives necessary and sufficient to accomplish or move toward the goals.
3. Are objectives required by contract or are they guidelines only?

##### Function:

1. Can certain objective functions be eliminated?
2. Are some functions unnecessary.
3. Do the objectives do more than the goals require?

Design:

1. Can the objective be completed by standard methods or procedures.
2. What alternatives were considered?
3. Why were alternatives rejected?

Special Requirements:

1. Is a severe environment involved in completion of the objective?
2. What special characteristics are required by the goals?
3. Are there special requirements relative to implementation? Maintenance? Control and feedback of the objectives?

Personnel:

1. What specialists will be needed to accomplish objectives?
2. Are administrative requirements excessive?

Implementation:

1. Do completion of objectives have serious social, political or environmental consequences.
2. Has the choice of objectives adversely affected the availability of implementation monies?
3. Are objectives attained in the present system? If so, how?
4. Who would be responsible? in-house? contractor? other agency?



5. Where else has it, or something similar been done?

6. Are there any particularly costly objectives?

Can they be modified to reduce costs?

7. Can feedback and control be effectively maintained?

Will visibility be adequate or difficult to maintain?

## Value Analysis-Speculative Step

### Purpose:

To generate alternate methods for accomplishing the objectives.

### Key Question:

What else will satisfy the objective requirements?

### Test for Value:

1. Is there a better system available?
2. Can a given objective be attained through a lower cost method?
3. Should it be done in-house or contracted out or given to another agency?

### Check lists for developing alternatives

#### General:

1. Can a goal be changed to eliminate an unnecessary objective?
2. Can standard methods be used to satisfy objectives?
3. If the objective is to improve aesthetics, is it justified?
4. Is there a less costly objective that will provide the same function?
5. Can the objective be changed to simplify its fulfillment?
6. Will the objective permit standard feedback and control techniques?
7. Can part of the present system be incorporated in the new plan?

### Methodology

1. Is a new methodology feasible? Necessary?
2. Are researched but untried methodologies available?

### Feedback and Control

1. What type of planning control do the objectives call for? Are variations possible?

2. Where is feedback necessary? Unnecessary?

Generate ideas, methods or procedures to fulfill the basic goals that the objective under study must perform:

## Value Analysis-Analytical Step

### Purpose:

1. To develop alternate approaches generated during the speculative phase, listing advantages and disadvantages of each.

2. To estimate the dollar value of each method.

3. To select methods which best fit the objectives at the least cost.

### Techniques:

1. Refine.

2. Use the service of government experts.

3. Put a dollar sign on the main ideas.

4. Use in-house cost.

5. Use your own judgement.

### Key Question:

What does it cost?

### Cost Analysis of Alternative approaches

Prepare gross cost estimates

1. Estimate variable cost of the alternatives.

2. Estimate fixed costs of the alternate procedures.

3. Estimate the costs of implementation.

4. Estimate the supporting and maintenance cost of alternate methods.

5. Estimate planning costs.

6. Estimate social costs.

7. Estimate environmental costs.

Select most promising approaches or concepts for carry over into Phase-A of PPP:

## Phase-A-Preliminary Analysis

### Content of Phase-A

1. Develop Planning Objectives Further
2. Assess Feasibility
3. Identify Supporting Requirements
  - a. Research and technological support.
  - b. Political support.
  - c. Social support.
  - d. Financial support.
  - e. logistics support.
4. Outline Major Changes and Additions to the Existing System.
5. Determine Gross Implementation Schedule.
6. Estimate Gross Resource Requirements
  - a. Funds and sources.
  - b. Manpower.
  - c. Facilities.
7. Conduct Impact Studies to Determine Advantages and Disadvantages of each Approach in these Areas
  - a. Economic impact.
  - b. Environmental impact.
  - c. Social-psychological impact.
  - d. Technological impact.
  - e. Political impact.
8. Trade-off Analysis.

9. Definition of Relationships to Follow-on and Other Projects.

Result of Phase-A

Feasible Project Concepts for Detailed Study

## Phase-B-Definition

### Content of Phase-B

1. Refine Selected Concepts from Phase-A.
2. Conduct Systems Analysis.
3. Determine Preliminary Specifications and Design Data.
4. Preliminary Assessments of Techniques for:
  - a. Construction.
  - b. Testing.
  - c. Maintenance.
  - d. Operation.
5. Define Social and Political Implementation Support Requirements.
6. Identify Safety Factors, Design Margins.
7. Detail Further Social, Environmental and Political Impact.
8. Preliminary Planning for Post-implementation Problems Identified in 7.
9. Identify Advance Technology and Development Requirements.
10. Assess Costs, Schedule and other Resource Requirements.
11. Define Management and Procurement Approaches.
12. Conduct Detailed Trade-off and Comparison Analyses.

### Results of Phase-B

1. Specific Project Approach.
2. Preliminary Specifications and Design.
3. Preliminary Schedule, Resource and Management Plans.



## Phase-C-Design

### Content of Phase-C

1. Develop Details of Design and Sales Concepts.
2. Technical Analysis from Engineering and Social Science Aspect.
3. Develop Specific Engineering, Architectural and Social Design.
4. Develop Plans for Implementation and Support.
5. Develop Costs and Schedule Estimates.
6. Refine Management Plans.

### Results of Phase-C

1. Project Design and Specifications Including Public Hearings and Implementation.
2. Plans for Implementation and Management.

## Phase-D-Development/Implementation

### Content of Phase-D

1. Development of Final Implementation Plans.
  - a. Technical Plan.
  - b. Management Plan.
  - c. Procurement Plan.
2. Implementation including
  - a. Construction.
  - b. Testing.
  - c. Maintenance and Operation.
  - d. Evaluation

### Results of Phase-D-Completed Project