

13 Mar 1991, 1:30 pm - 3:30 pm

Damage Criteria for Small Amplitude Ground Vibrations

K. Rainer Massarsch
Geo Engineering SA, Waterloo, Belgium

Bengt B. Broms
Nanyang Technological Institute, Singapore

Follow this and additional works at: <https://scholarsmine.mst.edu/icrageesd>



Part of the [Geotechnical Engineering Commons](#)

Recommended Citation

Massarsch, K. Rainer and Broms, Bengt B., "Damage Criteria for Small Amplitude Ground Vibrations" (1991). *International Conferences on Recent Advances in Geotechnical Earthquake Engineering and Soil Dynamics*. 6.

<https://scholarsmine.mst.edu/icrageesd/02icrageesd/session11/6>



This work is licensed under a [Creative Commons Attribution-Noncommercial-No Derivative Works 4.0 License](#).

This Article - Conference proceedings is brought to you for free and open access by Scholars' Mine. It has been accepted for inclusion in International Conferences on Recent Advances in Geotechnical Earthquake Engineering and Soil Dynamics by an authorized administrator of Scholars' Mine. This work is protected by U. S. Copyright Law. Unauthorized use including reproduction for redistribution requires the permission of the copyright holder. For more information, please contact scholarsmine@mst.edu.



Damage Criteria for Small Amplitude Ground Vibrations

K. Rainer Massarsch
Consultant, Geo Engineering SA, Waterloo, Belgium

Bengt B. Broms
Professor, Nanyang Technological Institute, Singapore

SYNOPSIS: European codes and recommendations have been reviewed with respect to critical vibration levels, causing damage to buildings. It was found that the variation of the vibration threshold levels was large between the different codes. A rational approach to assess the damage caused by ground vibrations is proposed, based on wave propagation theory. The wave length appears to be the most important parameter. The damage potential was found to be greatest when the length of the propagating wave is equal to or shorter than the length of the building. The wave length can be determined from the frequency and wave propagation velocity.

The critical dynamic ground distortion has been back-calculated from the requirements in the different codes and from published recommendations. The critical vertical particle velocity, causing damage, can be calculated if the wave propagation velocity is known. Also other factors such as the source of the vibrations, the building conditions and the degree of damage have been considered. A comparison of the proposed relationship with existing vibration criteria shows surprisingly good agreement.

INTRODUCTION

Research in soil dynamics has mainly been directed towards earthquake problems. Sophisticated computer programs have been developed to predict the effects of ground vibrations on e. g. nuclear power plants, high-rise buildings and off-shore structures. Advanced field and laboratory techniques are available to evaluate accurately dynamic soil parameters such as wave velocity and material damping.

Comparatively little attention has been paid to conventional vibration problems, such as the effect of vibrations on buildings and sensitive installations. These problems are usually solved by correlating measured vibration levels with observed damage. Proposed vibration criteria depend on the local conditions and they are difficult to apply elsewhere. Vibration criteria tend to be conservative, as pointed out by Holmberg et al. (1984). However, cases are known where damage has occurred even when the specified maximum values apparently have not been exceeded. Unexpected damage to structures caused by vibrations, as well as over-conservative restrictions concerning e. g. construction activities in built-up areas can have great economical consequences. A better understanding of the factors controlling damage to buildings from ground vibrations is therefore needed.

GROUND VIBRATION PROBLEMS

Ground vibrations are controlled by three main factors, the characteristics of the vibration source, the properties of the propagated medium, and the response of the affected

buildings. The vibration source can be natural (earthquakes) or man-made, such as blasting and other construction activities, e. g. soil compaction and pile driving. Vibrations can also be caused by traffic or by vibrating machines, presses, hammers etc. Vibrations can either be transient (impulse loading) or stationary.

The direction, amplitude and frequency of the vibrations are also affected by the dynamic properties of the soil or the rock through which they propagate. Usually, the amplitude and the frequency of vibrations decrease with increasing distance from the vibration source. However, under unfavourable conditions, the vibrations can be amplified locally, e. g. by resonance or by wave refraction or reflection along a stiff layer, (Massarsch, 1984).

The vibration level can be defined by three parameters: duration, frequency and amplitude of the vibrations. It is important to recognize that the dynamic parameters are strongly influenced by the vibration source. Figure 1 shows on a logarithmic scale the approximate range of vibration amplitudes and number of vibration cycles for six common vibration sources at frequencies between 10 and 60 Hz. It has been assumed that the life of the building is 30 years. The vibration amplitude as well as the number of vibration cycles can differ by several orders of magnitudes. This fact must be kept in mind when assessing the damage caused by ground vibrations.

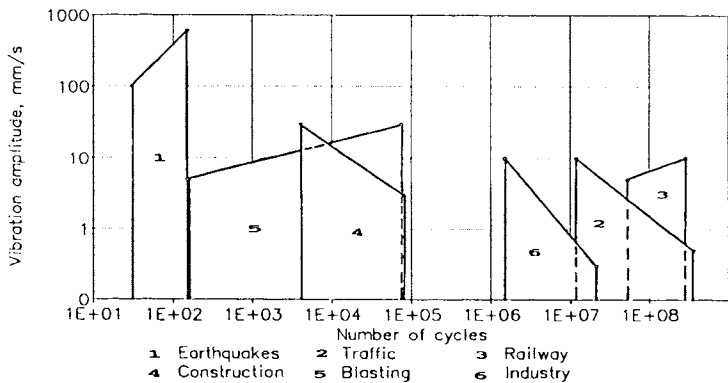

Fig. 1 Approximate upper range of vibration amplitude and number of vibration cycles (assumed life of building is 30 years)

The particle velocity is a convenient measure of the intensity of the vibrations and is widely used as a vibration criterion. However, it should be recognized that damage to structures can only be caused by differential displacements (strain) or by inertia forces (acceleration), (New, 1986). Structure can be subjected to both effects at the same time, and these will be superimposed upon the pre-existing stresses from other causes. Damage occurs when the combined effect exceeds the strength of the structure.

Vibrations can affect buildings located some distance away from the source (in the "far-field"). The frequency is usually significantly lower than 50 Hz. Thus, the accelerations are often not significant, except for structures founded on hard rock or located close to the source, (Langefors and Kihlström, 1978).

The potential damage is usually evaluated in terms of the peak particle velocity. This is the value which is associated with the motion of a particle at a point in the ground (or on the structure) and is widely considered to give the best correlation with observed damage, (New, 1986).

The vibration frequency is another important parameter, since resonance can occur between the induced ground vibrations and a building, (Massarsch, 1984). Therefore, vibration criteria often include a frequency range for which the given particle velocities apply.

VIBRATION CRITERIA

Vibration criteria can be chosen either with respect to the people living in a building, or to prevent damage to the structure. In many cases, critical vibration levels are based on environmental considerations, which are subjective. They are well below the threshold values for buildings. However, in the case of vibrations of short duration (blasting), or when environmental considerations are of secondary importance, such as for industrial buildings, structural considerations will control the vibration threshold level.

Tables 1 through 7, (Appendix I) summarize different codes and vibration criteria reported in the literature. These criteria are based on extensive field observations and on experience from vibration measurements in different European countries. In most cases, the peak vibration amplitude, the resultant of three largest amplitude components, is used. However, in Sweden, the vertical vibration amplitude is usually the limiting factor, (Holmberg et al., 1984).

Most damage criteria distinguish only between transient vibrations (mainly blasting) and stationary vibrations (from construction activities, traffic and machine vibrations). This is surprising, considering the variety of possible vibration sources, cf. Fig. 1.

In several cases, descriptions defining the damage caused by vibrations, are ambiguous, ranging from "safe limits" to "slight damage" and "cracking". Only in one case, (Langefors and Kihlström, 1978), reference is made to the dynamic properties of the soil (compression wave velocity).

A wide variety of building types, construction methods and foundation conditions exist in different countries. The definitions of building type and vibration sensitivity are sometimes difficult to interpret and need considerable judgement. Proposed vibration criteria can vary within wide limits for apparently similar conditions, some times by more than one order of magnitude. It is thus necessary to apply the different vibration criteria with caution.

A comparison of the vibration criteria used in different countries suggests, that a more fundamental approach is needed, (Massarsch, 1983). An attempt has therefore been made to identify the main factors that govern the damage caused by ground vibrations. These factors have been determined quantitatively, based on existing vibration criteria. A simple procedure is proposed to estimate the maximum vibration level.

WAVE PROPAGATION IN AN ELASTIC MEDIUM

It is possible to assess theoretically the effects of ground distortion on buildings caused by the propagation of elastic waves, as shown in Fig. 2, (Newmark, 1967). The figure illustrates the displacement of two points 1 and 2, located at a distance b apart.

The wave is assumed to propagate in the x -direction from 1 to 2. The corresponding displacement ρ is

$$\rho = f(x - ct) \quad (1)$$

in which c is the wave propagation velocity and t is the time. The derivatives of the displacement vector ρ with respect to x and t lead to the following two equations

$$\frac{\partial \rho}{\partial x} = - \frac{1}{c} \cdot \frac{\partial \rho}{\partial t} \quad (2)$$

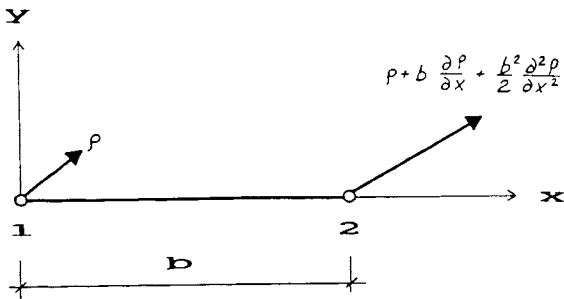

Fig. 2 Relative displacements between points 1 and 2

$$\frac{\partial^2 \rho}{\partial x^2} = - \frac{1}{c^2} \cdot \frac{\partial^2 \rho}{\partial t^2} \quad (3)$$

In the case where ρ is in the direction of x , then the maximum strain ϵ_m at Point 1 is obtained from Equ. (2)

$$\epsilon_m = - v_m / c \quad (4)$$

where v_m is the maximum particle velocity. When ρ is perpendicular to x , either horizontally or vertically, the maximum curvature k_m at Point 1 can be obtained from Equ. (3)

$$k_m = a_m / c^2 \quad (5)$$

where a_m is the maximum acceleration at Point 1. In the special case where the deflection transverse to the direction of wave propagation is sinusoidal (Fig. 3),

$$y = y_m \sin \pi x / b \quad (6)$$

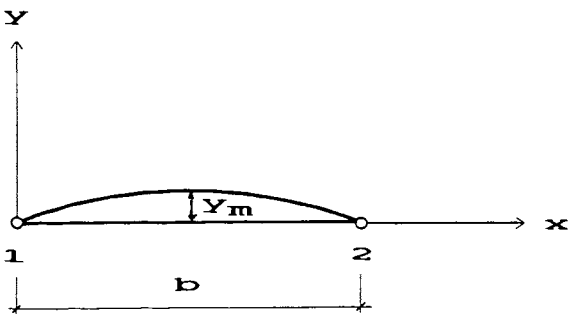

Fig. 3 Deflection by an arc of a sine wave, transverse to the wave propagation direction

The maximum curvature, k_{max} can then be calculated from

$$k_{max} = \left. \frac{\partial^2 y}{\partial x^2} \right|_{max} = - \frac{\pi^2}{b^2} y_m = - \frac{y_m}{c^2} \quad (7)$$

The maximum deflection can be determined from Equ. (5),

$$y_m = - \frac{b^2}{\pi^2} \cdot \frac{a_v}{c^2} \quad (8)$$

It should be noted that the acceleration a_v is perpendicular to the direction of wave propagation. By substituting the acceleration a_v by the velocity v_v according to

$$a_v = 2 \pi f v_v \quad (9)$$

where f is the frequency, and by rearranging the terms, the following relationship is obtained

$$\frac{y_m}{b} = \frac{2}{\pi} \cdot \frac{f}{c} \cdot \frac{v_v}{c} b \quad (10)$$

Since the wave length λ is defined as the ratio of the wave velocity and the frequency, then

$$c = f \lambda \quad (11)$$

If Eqs. (4) and (11) are substituted into Equ. (10)

$$\frac{y_m}{b} = \frac{2}{\pi} \cdot \frac{b}{\lambda} \cdot \frac{v_v}{c} \quad (12)$$

From this equation it can be seen that the ground distortion perpendicular to the direction of the wave propagation is affected by the following two dimensionless parameters, relative building length, b/λ and strain level v_v/c .

DAMAGE CAUSED BY STATIC GROUND DISTORTION

Damage criteria for structures subjected to settlements and heave have been discussed by e. g. Burland and Wroth (1974), Burland et al. (1977) and by Boscadin and Cording (1989). Two possible modes of deformation, bending and shear distortion are shown in Fig. 4. Heave is assumed to occur at the centre of the building, causing hogging. The maximum deflection or initial cracking will depend on the geometry of the building (ratio of L/H), on the location of the neutral axis and on the stiffness of the structure.

Burland and Wroth (1974) suggested that the initial cracking of a beam can be related to a critical tensile strain. Assuming that the beam behaves elastically before cracking, they developed theoretical relationships for different loading conditions. Fig. 5 shows that for structures with L/H -ratios larger than about 1.0, the first cracks will be caused by bending.

Boscadin and Cording (1989) have pointed out the importance of the horizontal strains on the cracking of buildings. As a structure is subjected to increasing lateral strains, its resistance to differential settlements decreases.

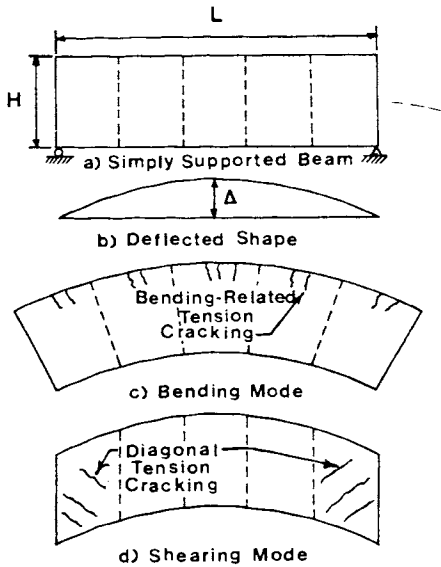

Fig. 4 Cracking of a simple beam in bending and in shear, hogging of load bearing wall, Boscardin and Cording (1989)

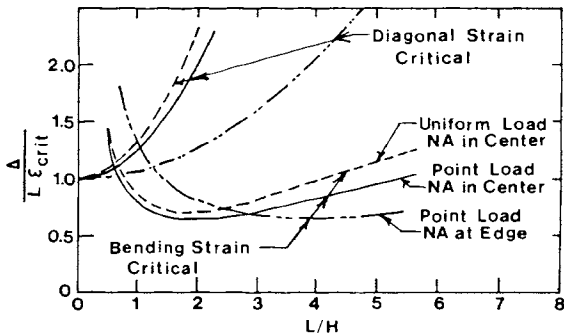

Fig. 5 Effect of loading conditions (bending and strain) and building geometry on the cracking of a beam, Burland and Wroth (1974)

The cracking potential of actual structures has been investigated by Burland et al. (1977). They reviewed available field data of building damage and concluded that load-bearing walls subjected to hogging are more susceptible to damage than frame buildings which are relatively flexible. The critical deflection ratio Δ / L (slight damage) for load-bearing walls was found to be about 2×10^{-4} .

DAMAGE CAUSED BY GROUND DISTORTION

It is not possible to apply damage criteria at static loading without modification to dynamic problems. However, also in the case of dynamic loading, the damage pattern is similar. As shown in Fig. 6, the shear distortions from dynamic ground motions cause the structure alternatively to sag and hog. Also the importance of wave length in relation to the length of the building becomes apparent.

Sagging Hogging

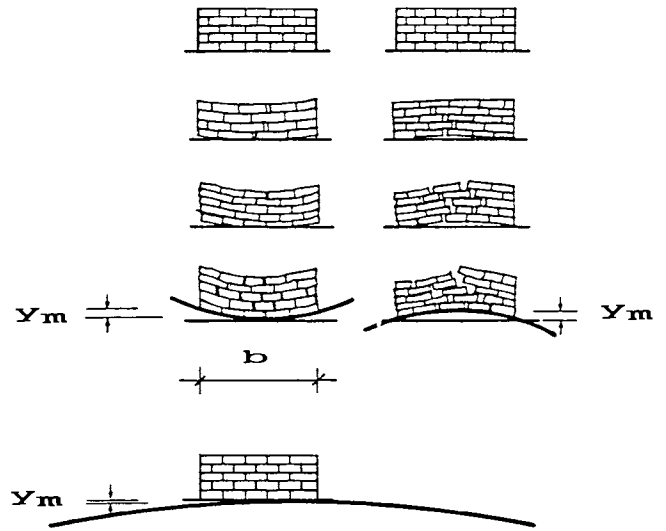

Fig. 6 Cracking of a brick wall caused by cracking due to hogging and sagging, demonstrating the significance of wave length for building damage

In the case of dynamic ground movements, the structure will be subjected to a large number of deformation cycles compared with static loading. On the other hand, the rate of loading is much higher at dynamic deformations, as well as the material stiffness of the structure. However, a direct, quantitative assessment of this effect is not possible.

From Fig. 6 it is apparent that the wave length is an important factor. The relationship between wave length, frequency and wave propagation velocity can be calculated from Equ. (11). It should be noted that the vibration frequency of waves does not vary much. The dominating frequency in soils from e. g. blasting (in the far-field), traffic, construction activities or vibrating machines is typically 20 to 50 Hz. However, in the cases where the P-waves dominate (near-field problem) or when the ground consists of very stiff material (competent rock), then vibration frequencies can be significantly higher. The frequency can be readily measured in the field with sufficient accuracy, using conventional vibration measuring equipment.

Another important parameter is the wave propagation velocity, which appears to be the single most important parameter. It influences the damage caused by dynamic ground distortions, Equ. (10). It is therefore interesting to note that wave velocity is hardly referred to in any of the vibration codes in Appendix I.

WAVE PROPAGATION VELOCITY

In an elastic, homogeneous medium, the vibration energy is transmitted by body waves (compression waves, P-waves and shear waves, S-waves) and by surface waves (Rayleigh waves, R-waves). In the case of a vertically vibrating

ooting at the ground surface, only about 7 % of the total vibration energy is transmitted by P-waves. The remaining 93 % are transmitted by S-, and R-waves.

The P-waves travel at significantly higher speed and at higher frequencies than the S-waves. The R-waves are just slightly slower than the S-waves (less than about 10 %). This difference can be neglected for most practical problems. Fig. 7 indicates the range of wave velocities for the P-, as well as the S-waves for different foundation materials, (Massarsch, 1983). These values are approximate and should be used with caution.

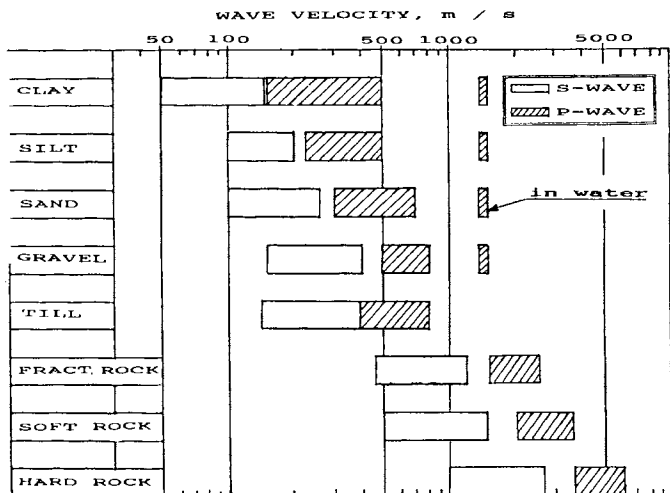

Fig. 7 Range of P-, and S-wave velocity for different geologic materials, Massarsch (1983)

The most accurate method of determining the wave propagation velocity is by field or laboratory tests. A variety of testing methods are available, such as cross-hole and down-hole measurements, or resonant column tests. For most problems, it is generally sufficient to determine wave velocities from semi-empirical relationships. Fig. 8 shows the relationship for saturated soils between the S-wave velocity, void ratio and depth, (Massarsch, 1984). It should be noted that in soft soils, the S-wave velocity is strongly influenced by the void ratio, e and by the effective overburden pressure.

Based on this information it is possible to estimate the wave length with sufficient accuracy. Assuming a typical case of traffic vibrations (dominating frequency around 15 Hz), affecting a residential building (length 10 m) founded on clay or sand (surface wave velocity about 200 m/s), the wave length is about 15 m. Thus the ratio of building length to wave length falls within the critical range as discussed above, cf. Fig. 6.

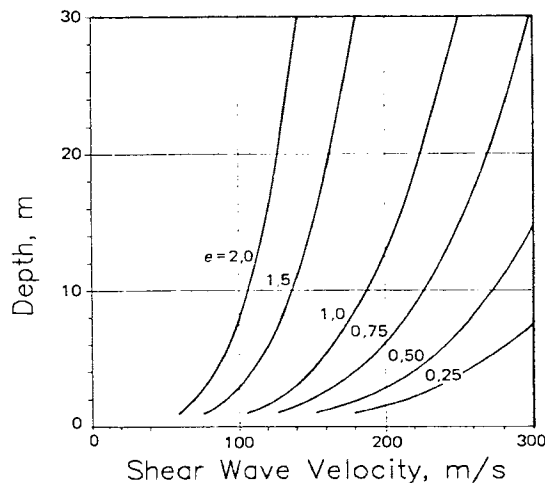

Fig. 8 Shear wave velocity of saturated, normally consolidated soils as a function of depth and void ratio, Massarsch (1984).

DETERMINATION OF CRITICAL DAMAGE PARAMETERS

The main factor which controls cracking of buildings is the deflection ratio y_m/b , cf. Equ. (12). This parameter can be back-calculated from the vibration criteria given in Appendix 1.

It should be noted that in Equ. (12), the vertical particle velocity must be used. Where only peak particle velocities are given, it has been assumed that the three velocity components are equal. The indicated values have then been multiplied by a factor 0,6 ($1/\sqrt{3}$).

An indication is given in most codes about the soil conditions for which the respective velocity values apply. Typical values of the R-wave velocity were estimated from Fig. 7.

The frequency range is given in several cases. When such values were not available, assumptions have been made, which are consistent with similar values in other codes. In the following analysis an average building length of 10 m has been assumed and particle velocities corresponding to "slight damage" (threshold of damage) were chosen. Only values referring to impulse loading have been considered.

Based on these assumptions, the critical deflection ratio y_m/b could be back-calculated. Not surprisingly, there was some scatter of data points, but an average value of $y_m/b = 1,5 \times 10^{-5}$ was obtained. It is interesting to note that this value is about one order of magnitude lower than the critical strain, determined by Burland et al. (1977) for static deformations. This is not surprising, considering that wave propagation causes a considerably larger number of loading cycles of both hogging and sagging. In addition, the horizontal strain, which can often be neglected at static loading, is at dynamic loading an important factor. It can be of the same order of magnitude as the vertical strain.

PROPOSED VIBRATION CRITERIA

In order to arrive at a rational method to predict the maximum permissible vibration levels of dynamic ground distortions, Equ. (12) was rearranged

$$\frac{v_v}{c} = \frac{y_m}{b} \cdot \frac{\pi}{2} \cdot \frac{h}{b} \quad (13)$$

from which the critical vertical vibration velocity can be readily determined. This expression can be further simplified by assuming a typical length of the buildings which corresponds to half the wave length ($b = \lambda/2$). By substituting this critical deflection ratio ($y_m/b = 1,5 \cdot 10^{-5}$) into Equ. (13), the following simple expression is obtained

$$v_v = 4,7 \times 10^{-5} c \quad (14)$$

It should be noted that this relationship can only be used for impulse loading to predict the initial cracking of buildings. In order to take into account other important factors such as the rate of loading and the number of vibration cycles, building type and type of damage, three empirical parameters are used to modify Equ. (14). They were chosen based on the vibration codes used in Germany and Switzerland, Appendix 1.

Vibration source	A ₁
Impulse load	1,0
Repeated	0,6
Stationary	0,3

Building category	A ₂
Very sensitive structures, historic monuments etc.	0,5
Vibration-sensitive buildings (with masonry walls and plaster) conventional foundations	1,0
Buildings with good foundations, concrete walls, structure not vibration sensitive	1,5
Steel or reinforced concrete structures, industrial premises	2,5

Degree of damage	A ₃
Negligible	0,7
Slight damage	1,0
Moderate damage	2,0
Severe damage	4,0

When these empirical factors are included in Equ. (13) the following relationship is obtained,

$$v_v = 4,7 \times 10^{-5} \times A_1 \times A_2 \times A_3 \times c \quad (14)$$

It should be noted that the measured vertical particle vibration velocities v_v , measured on the building foundation should be used. If amplification occurs in the building as a result of resonance, this effect should be included, by averaging the vibration velocity measured on the ground and at the highest level in the building. In general, an amplification factor of 2 to 6 can be expected at resonance.

Appendix I and the equivalent values calculated from Equ. (14). Considering the simplicity of Equ. (14), and the large variation of vibration criteria in the codes, a surprisingly good correlation is obtained.

SUMMARY AND CONCLUSION

Existing vibration codes and recommendations, published in the literature, are empirical and based on observations of damaged structures. They are strongly affected by the local soil conditions. Therefore, it is difficult to apply these criteria in other countries.

It can be shown both theoretically and by reviewing the literature that ground distortion caused by static and dynamic loading, is the single most important factor controlling the damage to structures.

The ratio of the wave length with respect to building length has been found to control the degree of damage. The wave length can be readily determined from the dominating frequency and the wave propagation velocity. For most buildings, the wave length is about twice the length of conventional structures.

A simple relationship has been proposed, which considers the most important factors, that contribute to damage caused by dynamic ground distortion. A comparison with existing codes in different countries shows a good correlation, considering the large difference between existing codes and recommendations.

However, it should be recognized that also other factors can damage the structures, such as dynamic forces (especially at high frequencies in the near-field), or when resonance occurs between the induced vibrations and the structure.

Vibrations can also cause settlements below a building. Loose, saturated sands and silts are especially susceptible to horizontal and vertical accelerations, and can contribute to large differential settlements, especially of light buildings.

It should be pointed out that damage to buildings can also be caused by other factors than dynamic effects. Small cracks will develop with time in walls and ceilings due to changes in temperature and humidity, and by freezing and thawing. The quality of construction of the building plays thereby an important role.

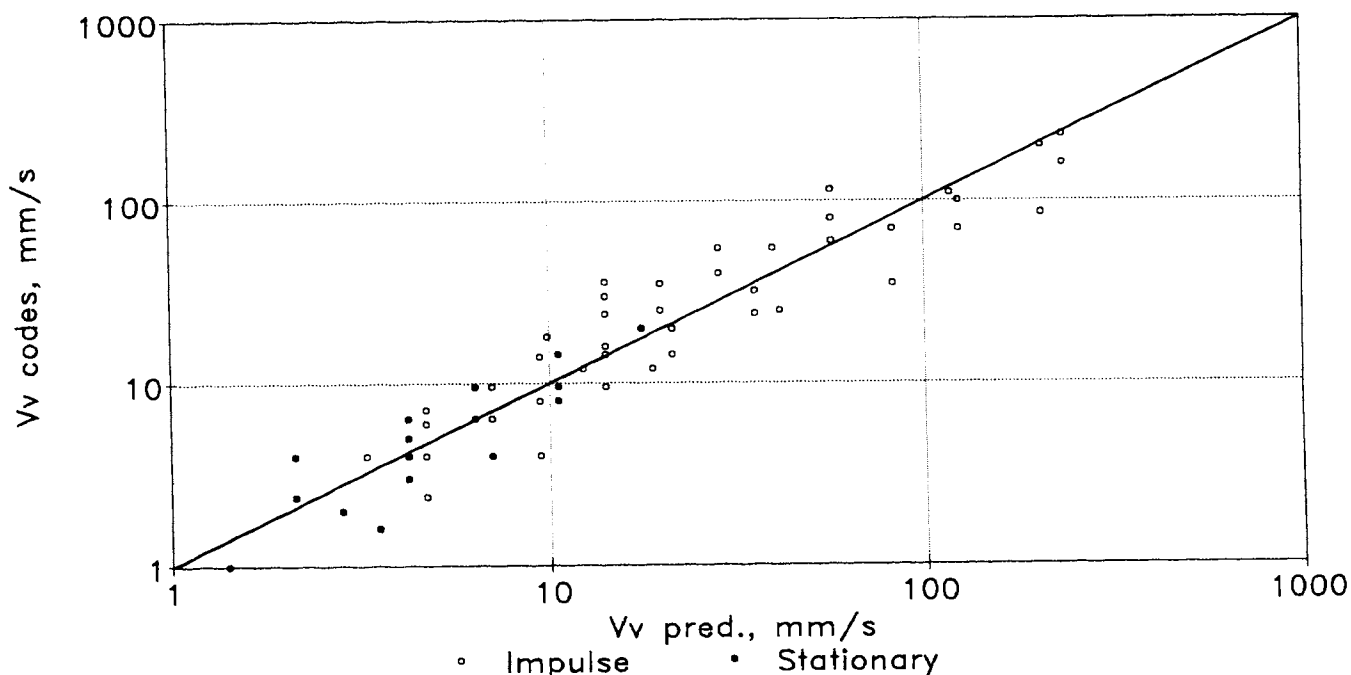

Fig. 9 Comparison of vertical particle velocity, calculated from Appendix 1 and Equ. (14)

REFERENCES

- Bonde, G. and Rundquist, G. (1981), "Känslighet för trafikstrade vibrationer", (Sensitivity to traffic-induced vibrations), Institute of Technology, Uppsala University, UPTec 81 42 R, TRAVI-K, 97 p.
- Boscardin, M. D. and Cording, E. J. (1989), "Building response to excavation-induced settlements", Journal of Geotechnical Engineering, ASCE, Vol. 115, No. 1, pp. 1 - 22.
- Burland, J. B. and Wroth, C. (1974), "Settlements of buildings and associated damage", Proceedings, Conference on Settlements of Structures, Pentech Press, London, pp. 611 - 654.
- Burland, J. B., Broms, B. B. and de Mello, V. F. B. (1977), "Behaviour of Foundations and Structures, State-of-the-Art Report, Proceedings, IX. International Conference ISSMFE, Tokyo, pp. 495 -546.
- DIN 4150, Teil 3. (1986), "Erschütterungen im Bauwesen, Einwirkungen auf bauliche Anlagen" Deutsches Institut für Normungen e.V. (DIN), Berlin 30, 6 p.
- Forssblad, L. (1981). "Vibratory soil and rock fill compaction", Dynapac Maskin AB, Solna, Sweden, pp. 153 - 155.
- Holmberg, R. et al. (1984), "Vibrations Generated by Traffic and Building Construction Activities", Swedish Council for Building Research, Report D15:1984, Stockholm, 114 p.
- Langefors, U. and Kihlström, B. (1978), The Modern Technique of Rock Blasting, Third Edition, AWE/Gebers, Stockholm, 438 p.
- Massarsch, K. R. (1983), "Skador på byggnader från vibration i jord och berg" (Damage from vibrations in soil and rock), Vibrationsdag 1981, Rapport 251, Ingenjörsvetenskapsakademien, Stockholm, pp. 7-20.
- Massarsch, K. R. (1983), "Vibration Problems in Soft Soils", Proceedings, Int. Symposium on Recent Developments in Laboratory and Field Tests, Bangkok, pp. 539-549.
- Massarsch, K. R. (1984), "Vibrations i jord och berg" (Vibrations in Soil and Rock), Handboken Bygg Geoteknik, Liber Förlag, Stockholm, pp. 517-525.
- New, B. M. (1986), "Ground Vibrations Caused by Civil Engineering Works", TRRL Research Report No. 53, 19 p.
- Newmark, N. M. (1967), "Problems in wave propagation in soil and rock", Proceedings, Int. Symposium on Wave Propagation and Dynamic Properties of Earth Materials, University of New Mexico, pp. 7 -21.
- Persson, P. A. et al. (1980), "Underground blasting in a city", Proceedings, Rockstore '80, Stockholm, Bergman Ed. Pergamon Press, Oxford, Vol. 1, pp. 199 - 206.
- Studer J. and Susstrunk A. (1981), "Swiss Standard for Vibrational Damage to Buildings", Proceedings, X. Int. Conf. ISSMFE, Stockholm, Vol 3., pp. 307-312

APPENDIX I

TABLE 1. Guide values for peak particle velocity during transient shaking
DIN 4150, Part 3 (1986)

Type of structure	Peak particle velocity at foundation, mm/s		
	< 10	Frequency, Hz 10 - 50	50 - 100
Offices, industrial premises and similar	20	20 - 40	40 - 50
Domestic houses and similar structures	5	5 - 15	15 - 20
Buildings especially sensitive to vibrations and historic monuments	3	3 - 8	8 - 10

TABLE 2. Limiting values to protect buildings from damage, Swiss standard for vibration effects on buildings, SN 640312, (1978)

Type of structure	Peak particle velocity (mm/s)		
	Frequency (Hz)	Blasting	Traffic/machines
Reinforced concrete and steel structures (without plaster), industrial and commercial buildings	10-60	30	
	60-90	30 - 40	
	10-30		12
	30-60		12 - 18
Buildings with foundation walls and floors in concrete, walls in concrete or masonry	10-60	18	
	60-90	18 - 18	
	10-30		8
	30-60		8 - 12
Buildings with foundation walls, basement wall in concrete, wooden floors and masonry walls	10-60	12	
	60-90	12 - 25	
	10-30		5
	30-60		8 - 8
Structures sensitive to vibrations, monuments of historic interest	10-60	8	
	60-90	8 - 12	
	10-30		3
	30-60		3 - 5

TABLE 3. Risk of damage in ordinary dwelling houses with varying ground conditions, Langefors and Kihlström (1978)

Type of damage	Sand, shingle, clay under g. w. level	Moraine, slate soft limestone	Hard limestone, quartzite sandstone, gneiss/granite
	300 - 1500	Wave velocity (m/s) 2000 - 3000	4500 - 6000
Vibration velocity (mm/s)			
No noticeable cracks	4 - 18	35	70
Insignificant cracking (threshold value)	6 - 30	55	110
Cracking	8 - 40	80	160
Major cracks	12 - 60	115	230

TABLE 4. Some typical vibration limits enforced in Sweden, foundation on hard rock. Valid for short duration construction blasting, Persson et al, (1978)

Object	Limiting peak vibration values		
	Amplitude (mm)	Velocity (mm/s)	Acceleration (mm/s ²)
Concrete bunker: Steel reinforced		200	
High rise apartment block: Modern concrete and steel frame design	0,4	100	
Underground rock cavern roof: Hard rock, span 15 - 18 m		70 - 100	
Normal block of flat: Brick of equivalent walls		70	
Light concrete building		35	
Swedish National Museum: Building structure		25	
Sensitive exhibits			5
Computer centre: Computer supports	0,1		2,5
Circuit breaker control			0,5 - 2

TABLE 5. Recommended limit values (vertical particle velocity) for traffic Bonde et al, (1981)

Type of building and foundation	Recommended limiting value (mm/s)
Especially sensitive buildings and buildings of cultural and historical value	1
Newly-built buildings and/or footing foundations	2
Buildings on cohesion piles	3
Building on end-bearing or friction piles	5

TABLE 6. Maximum permissible (vertical) vibration velocity, related to risk from vibratory compaction, Forssblad (1981)

Effects on buildings	Maximum permissible vibration velocity (mm/s)
Risk limit for ruins and ancient monuments	2
Risk limit for architectural damage to normal dwelling houses (plaster walls)	5
Risk limit for damage to normal dwelling houses	10
Risk limit for concrete buildings, industrial buildings etc.	10 - 40

TABLE 7. Safe blasting vibration thresholds for houses, New (1986)

Frequency (Hz)	Peak particle velocity (mm/s)
10	12
20	25
40	55