Masters Theses

Student Theses and Dissertations

1957

A probe for measuring ultrasonic pressures

Robert F. Rohrer

Follow this and additional works at: https://scholarsmine.mst.edu/masters_theses



Part of the [Physics Commons](#)

Department:

Recommended Citation

Rohrer, Robert F., "A probe for measuring ultrasonic pressures" (1957). *Masters Theses*. 2563.
https://scholarsmine.mst.edu/masters_theses/2563

This thesis is brought to you by Scholars' Mine, a service of the Missouri S&T Library and Learning Resources. This work is protected by U. S. Copyright Law. Unauthorized use including reproduction for redistribution requires the permission of the copyright holder. For more information, please contact scholarsmine@mst.edu.

A PROBE FOR MEASURING
ULTRASONIC PRESSURES

BY

ROBERT F. ROHRER

A

THESIS

submitted to the faculty of the

SCHOOL OF MINES AND METALLURGY OF THE UNIVERSITY OF MISSOURI

in partial fulfillment of the work required for the

Degree of

MASTER OF SCIENCE, PHYSICS MAJOR

Rolla, Missouri

1957

Approved by -

Professor of Physics

ACKNOWLEDGMENT

The author wishes to express his appreciation to Dr. Harold Q. Fuller, Professor of Physics, M. S. M., for his careful reading and suggestions in the preparation of this paper; to Dr. Dudley Thompson, Professor of Chemical Engineering, M. S. M., for suggesting this work and for his interest, suggestions, and encouragement throughout the investigation; to Professor Richard Schoen for many helpful ideas and discussions; to Mr. Harry Hardebeck for his assistance in the experimental work and for his help in the electronic instrumentation; to Mr. H. L. Pruett, who built various parts of the equipment; to Mr. Wendell Miller and Mr. Graydon Hanson, who helped in the taking of experimental data; and to the Electrical Engineering Department of M. S. M. for the use of several electrical instruments.

CONTENTS

	Page
Acknowledgments	i
List of illustrations	iii
Introduction	1
Review of literature	3
The probe	12
Oscillator and resonant circuit	18
The crystal holder and tank	22
The radiometer	25
Screening	30
Experimental procedure	33
Data and results	38
Limitations	43
Recommendations	44
Conclusions	45
Appendix A	46
Bibliography	47
Vita	49

LIST OF ILLUSTRATIONS

Figure	Page
1. An ultrasonic radiometer	4
2. Greutzmacher apparatus for measuring sound intensity...	6
3. Streamlines of flow past a Rayleigh disc	7
4. Hehlgans arrangement for calibrating quartz used as sound receiver.....	10
5. Preliminary probe	14
6. Probe used for readings	15
7. The probe used in the experiment	16
8. Oscillator circuit.....	19
9. Resonant circuit associated with crystal transducer show- ing transformer, etc.	20
10. The crystal holder for radiating ultrasonic beam horizontally.....	23
11. The radiometer	26
12. The radiometer used in the experiment	27
13. The screening used for the crystal showing Masonite box covered with aluminum foil, wire screen, and coax- ial cable.....	31
14. The experimental equipment for measurements with the probe.....	36
15. Polar distribution of sound intensity for the ultrasonic field in the oil.....	41

INTRODUCTION

In the study of acoustics, the term ultrasonics is defined as those wave motions that have frequencies greater than about 20,000 cycles per second. The characteristics of a sound wave at any point in a medium can be regarded as completely defined when the amplitude, frequency, and phase of its Fourier components are known.*

Sound measurements at their best are difficult. In the last few years sensitive linear microphones and electronic amplifiers have become available. Still, there are two difficulties of prime importance with their use in a sound field. First, there is the precise, absolute calibration of the equipment over a wide range of sound frequencies and intensities. In addition, any detection device whose dimensions are comparable to the wave length of the sound introduces a disturbing effect upon the field of sound itself. Also, there is always the possibility of reflected sound being picked up by the detector.

Intensity or pressure measurement of audible sound and ultrasonic sound contains many experimental errors and great care is necessary in order to secure an accurate determination.

All known measuring devices are limited in that their indications are dependent on the dimensions relative to the wave length of the incident sound. Any type of detector is dependent among other influences on

*Wood, A. B., A Textbook of Sound. London; G. Bell and Sons, Ltd., p. 461.

the following factors: (a) wave length of the incident sound, (b) the law of pressure volume variation assumed in the neighborhood of the obstacle, (c) the scattering and diffraction of sound energy from the obstacle.*

Most pressure or intensity measuring devices such as radiometers or Rayleigh discs, are inconvenient and laborious to use. Yet, in some types of research work in physics, chemical engineering, and other phases of the physical and biological sciences, it is desirable to measure ultrasonic pressure at various points in liquids. Relative intensity measurements as well as absolute intensity measurements are needed.

It is the purpose of this investigation to design, construct, and calibrate an ultrasonic probe for measuring ultrasonic pressures. With this probe, measurements of the sound pressures in the ultrasonic field can be obtained and the ultrasonic field can be mapped.

REVIEW OF LITERATURE

The study of intensity of ultrasonic waves may be divided into three main experimental methods; i. e., (a) mechanical methods, (b) thermo-acoustic methods, and (c) electrical methods.

A method quite often used for experimental measure of ultrasonics is shown in Figure 1. The apparatus is a radiometer which works on the principle of a torsion balance.*

It is so arranged that the ultrasonic energy impinges on a mica disc. The disc is balanced by a weight and the radiometer is rotated by the unidirectional pressure.

The pressure of the ultrasonic wave on its face depends on the amount of reflection from the disc, and it is therefore important that the disc reflect a large percentage of the total energy. Since the reflection between a solid and air is practically 100 per cent, most of the discs consist of two thin sheets of mica with an air space imprisoned between them. The pressure on this disc is then indicated by the amount of angular rotation of the radiometer.

A simple method for determining relative intensity measurements of ultrasonics was developed by Richards.** In this experiment, a thick-walled glass funnel with an approximate exponential opening is dipped in the liquid in which the field of sound is to be investigated. To the funnel is joined a

*Carlin, Benson., Ultrasonics. First edition, New York; McGraw-Hill Book Company, p. 29.

**Richards, W. T., An Intensity Gauge for Supersonic Radiation in Liquids. Proc. Nat. Acad. Sci. Wash., pp. 15, 310 (1929).

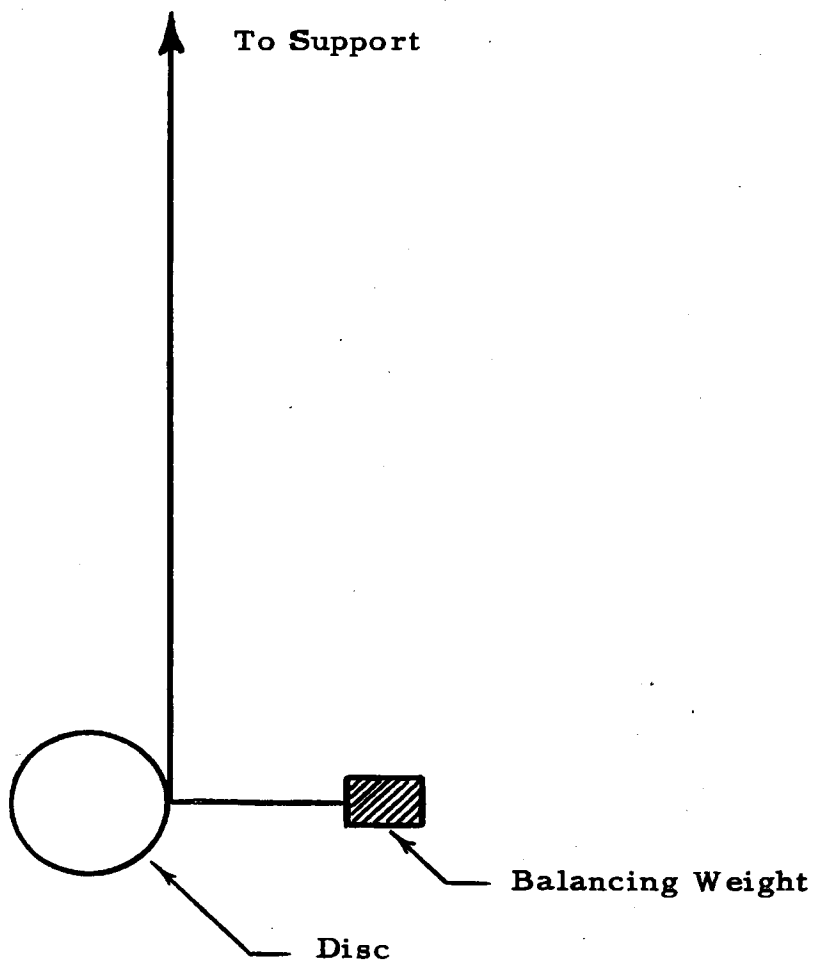

Figure 1

AN ULTRASONIC RADIOMETER

capillary of about 1 to 2 millimeters in diameter. When the funnel is dipped in the liquid, the liquid rises in the capillary. If the sound waves meet the funnel opening at right angles, the radiation pressure causes the surface of the liquid in the capillary to rise. This rise is a measure of the sound intensity.

A method similar to the one above is that by Gruetzmacher.* A diagram of this method is shown in Figure 2. A glass rod G dips at one end into the ultrasonic field. In this instance, the sound waves are traveling in a vertical direction in a container filled with oil. There is a glass bulb K at the other end of the glass rod. The interior of the bulb is in connection with the manometer through a rubber tube S. The glass rod is held by a rubber thread. The ultrasonics are lead to the bulb by the glass rod even around the bend since its radius is large compared with the wave length. This gives rise to an increase of temperature of the air in the bulb which produces a change in the manometer reading and thus indicates a measure of the sound intensity.

A small Rayleigh disc made out of mica or some other extremely thin material will respond to the particle velocity when introduced into a sound field from a suspension. An illustration of this effect is shown in Figure 3.

Here a plane lamina is introduced into a stream at an angle of 45° with respect to the stream. The points Q and R where the hyperbolic arcs meet the lamina are points of maximum pressure. The fluid pressures on the lamina act like a couple setting it perpendicular to the stream.

*Gruetzmacher, J., Piezoelektrischer Kristall mit Ultraschallkonvergenz. Z. Phys. 96, p. 342 (1935).

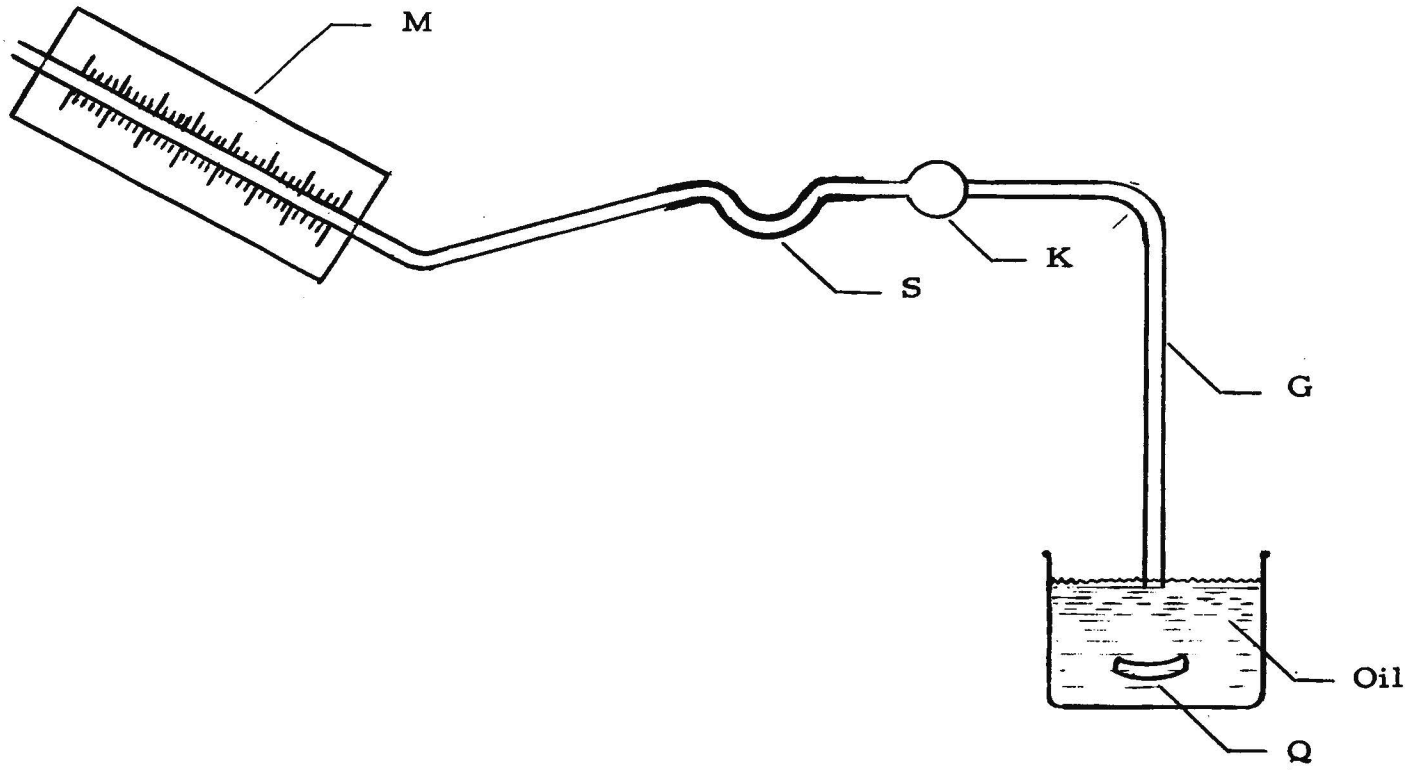

Figure 2

GRUETZMACHER APPARATUS FOR
MEASURING SOUND INTENSITY

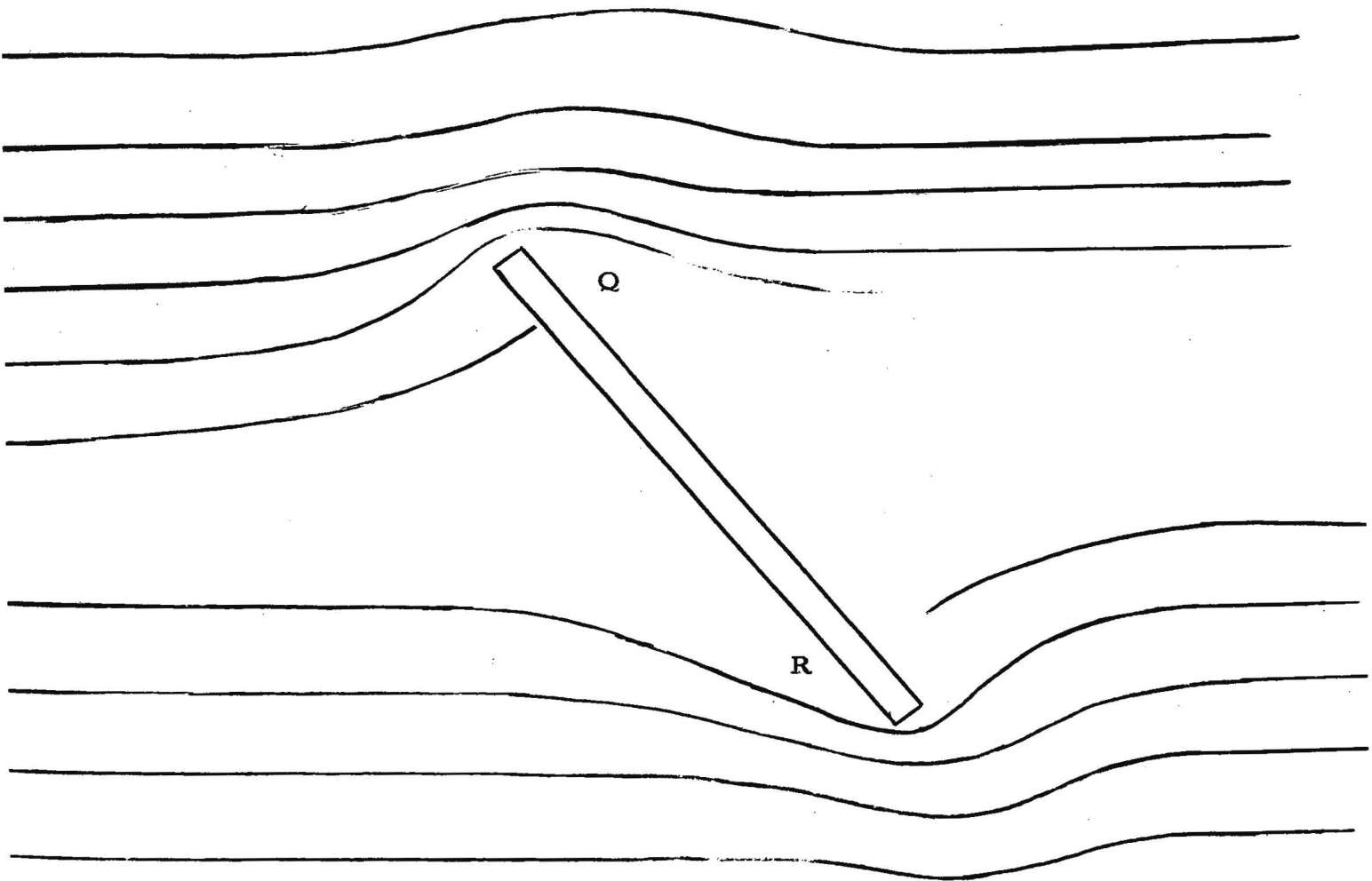

Figure 3

STREAMLINES OF FLOW PAST A RAYLEIGH DISC

Therefore, the sound field exerts a torque which will cause the disc to rotate about a diametrical axis. A small mirror can be attached to the suspension or to the disc itself in order to measure the deflection. However, the diameter of the disc must be small compared with the wavelength and this makes the disc impractical for most ultrasonic work.

Thermal receivers have been developed by a number of investigators during the past few years. These thermal receivers are sometimes called thermo-microphones. These receivers depend upon the change in resistance of thin wires, heated by a current, when the receivers are placed in an ultrasonic field. According to Bergmann,* this phenomena has three main effects. In a stationary sound wave the particles of the medium are at rest at the nodes. Due to the adiabatic changes of pressure, the particles are subject to changes of temperature and thus, a metal wire placed in the node is cooled and heated relative to a fixed temperature and this results in periodic changes in its electrical resistance. This is called the "node effect." For the loops of a sound wave, the conditions are different. In this case, the particles of the medium have the temperature of their surroundings, but a directed velocity. Therefore, they exert a cooling effect on a heated wire, causing periodic reductions in its resistance of double the frequency of the sound. This is called the "vibration effect." In the third case, the alternating current of air is combined with a unidirectional current which may be formed by a component of the convection current formed by the heated wire and having the direction of the sound vibrations. This case, where the cooling effect of the convection

*Bergmann, L., Ultrasonics. New York; John Wiley and Sons, Inc., 1938.

current is alternately increased and decreased by the vibration of the air, is called the "convection current effect." In ultrasonic work the high frequencies in general prevent the periodic temperature changes from being directly observed because of the thermal capacity of the wires. Therefore, it is necessary to determine the steady difference between the mean temperatures of the wire with and without sound. This is called the "steady cooling effect" and for this purpose, the wire forms one arm of a sensitive Wheatstone bridge.

Piezoelectric crystals are the only electrical receivers suitable for use in ultrasonics. Ordinary forms of microphones are too insensitive for high ultrasonic frequencies because of their great mass.

Sacerdote* has constructed a very small condenser microphone which has an aluminum diaphragm 0.8 centimeter in diameter and a few microns thick. This microphone is sensitive up to frequencies of 90 kilocycles.

The first to suggest the use of piezoelectric receivers was Langevin.** He proposed that the resulting alternating voltage put out by the receiver should be amplified and detected by a beat method.

The first quantitative ultrasonic measurements with piezoelectric crystals as receivers were done by Hehlgans.*** The quartz receivers used by him were in the form of rods and Figure 4 shows the quartz receiver and his arrangement for calibrating this quartz receiver. As shown in this figure, a crystal detector D was put in parallel with a highly sensitive

*Sacerdote, G., Microfoni per ultrasoni. Acta Frequenza 2, p. 516 (1933).

**Langevin, M. P., Sondage par le son spec. Publ. Intern. Hydrogr. Bureau Monaco No. 3, p. 34 (1924).

***Hehlgans, F. W., Uber piezoquarzplatten als sender und empfangen hochfrequenter akustischer schwingungen. Anal. Phys., Lpz. IV 86, p. 587 (1928).

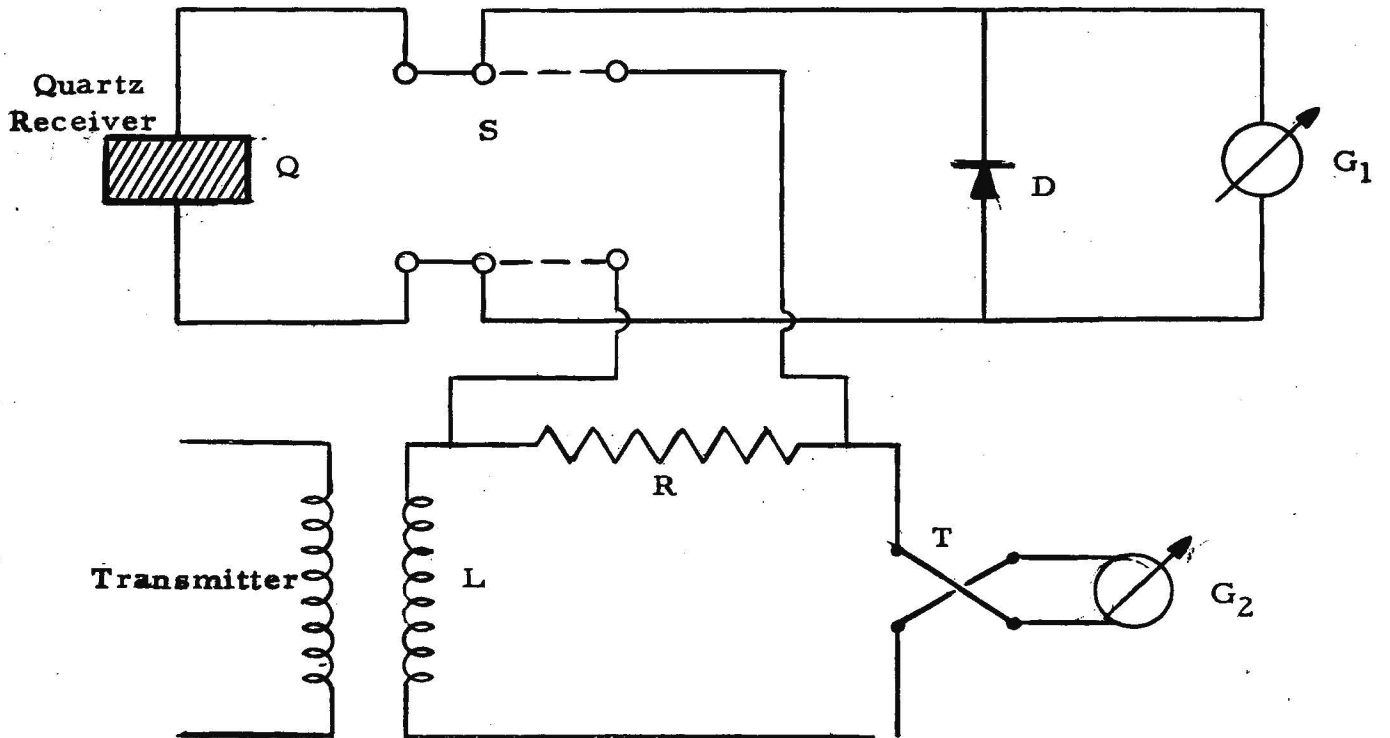

Figure 4

HEHLGANS ARRANGEMENT FOR CALIBRATING
QUARTZ USED AS SOUND RECEIVER

galvanometer G_1 . It was possible to calibrate this receiving circuit by replacing the quartz Q by a resistance R by means of a changeover switch S . This resistance R is then traversed by an alternating current having the natural frequency of the quartz. This current is measured by a thermocouple T and galvanometer G_2 . An oscillator in the coil L produced this current. The deflection of the galvanometer G_1 is proportional to the mean square of the current delivered by the quartz receiver. The mean square of the current is proportional to the pressure amplitude of the sound waves received. The deflection of the galvanometer G_1 is proportional also to the mean square of the pressure amplitude, hence the intensity of the wave received.

THE PROBE

Several small polarized barium titanate elements were obtained from Brush Electronics Company, Cleveland, Ohio. These elements are in the shape of hollow cylinders $1/16$ inch long by $1/16$ inch wide with a wall thickness of $1/100$ inch. The cylinders were open at both ends and were silver plated inside and out.

The problem essentially consisted of mounting this cylinder at the end of the probe which is immersed in the oil media carrying the ultrasonic field. When the crystal element is operating successfully, the ultrasonic wave strikes the crystal wall and the wall is set into vibration. This mechanical vibration produces electrical charges on the inside and outside surface of the cylinder because of the piezoelectric properties of the barium titanate crystal. When leads are attached to the inside and outside walls of the crystal and then connected to a vacuum tube voltmeter, an alternating current voltage should be detected.

Several factors are of extreme importance in the design of a probe;

- (a) the probe and the receiving crystal should be small, preferably several times smaller than the wave length of the ultrasound so that the distortion of the field is not too great;
- (b) it is necessary to take great care in screening the receiving barium titanate crystal and its circuit connections from the high frequency electromagnetic field of the quartz crystal transducer;
- (c) the leads and probe itself must not be attached too tightly to the receiving crystal or else damping may occur and the crystal will not operate properly.

A probe was designed and built with the previously mentioned factors in mind. A diagram of this probe is shown in Figure 5.

The main body of the probe was a hypodermic needle secured from a veterinarian. Very fine "litz" wire extended down the center of the needle and was scraped at the end and brushed out into the center of the ceramic. The "litz" wire was then pulled up slightly to provide tension. A brass ferrule was fitted into the ends of the needle similar to an "O" ring and the crystal was pushed into the fitting with ordinary finger pressure. The steel needle itself then served as the other lead away from the crystal. A ruby jewel was sealed into the end of the crystal to prevent oil from seeping up and shorting out the "litz" wire. A small brass cylinder was placed around the top of the needle for shielding purposes and a coaxial fitting was placed at the top of the brass cylinder. A coaxial cable led from the coaxial fitting to the vacuum tube voltmeter.

The probe, however, proved very unsatisfactory and would not work piezoelectrically. An amplifier with a gain of approximately 160 was connected into the circuit but failed to improve the response in any way. It appeared that this probe was unsatisfactory due to the damping and poor electrical contact.

The second probe is shown in Figure 6 and Figure 7. Here the ceramic is suspended completely below the needle. A thin stretched watch spring wire was extended down the center of the needle. The end of the wire was bent and placed in the ceramic cylinder in the manner shown in Figure 6. The wire was held in place by friction between the wall and wire.

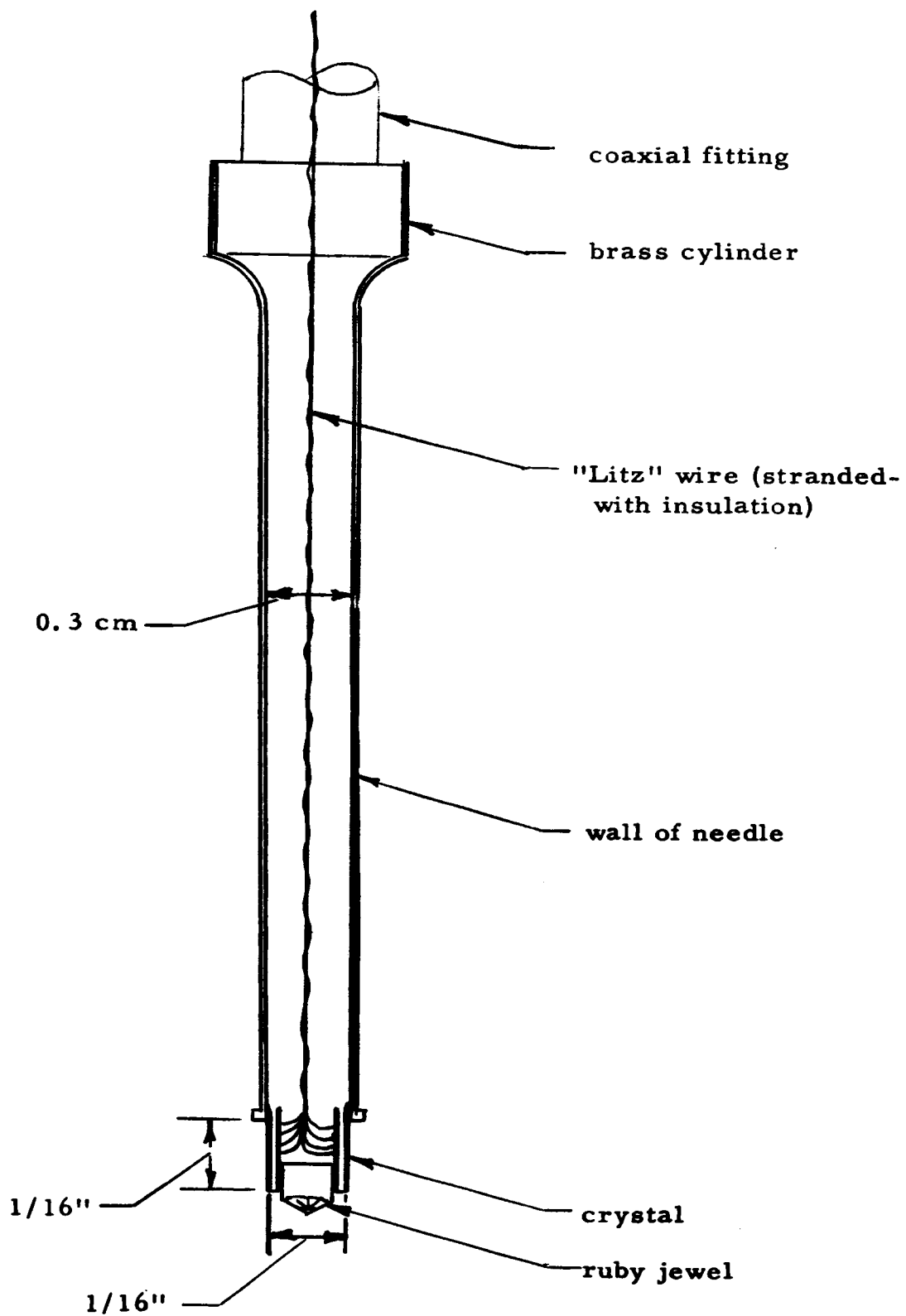

Figure 5

PRELIMINARY PROBE

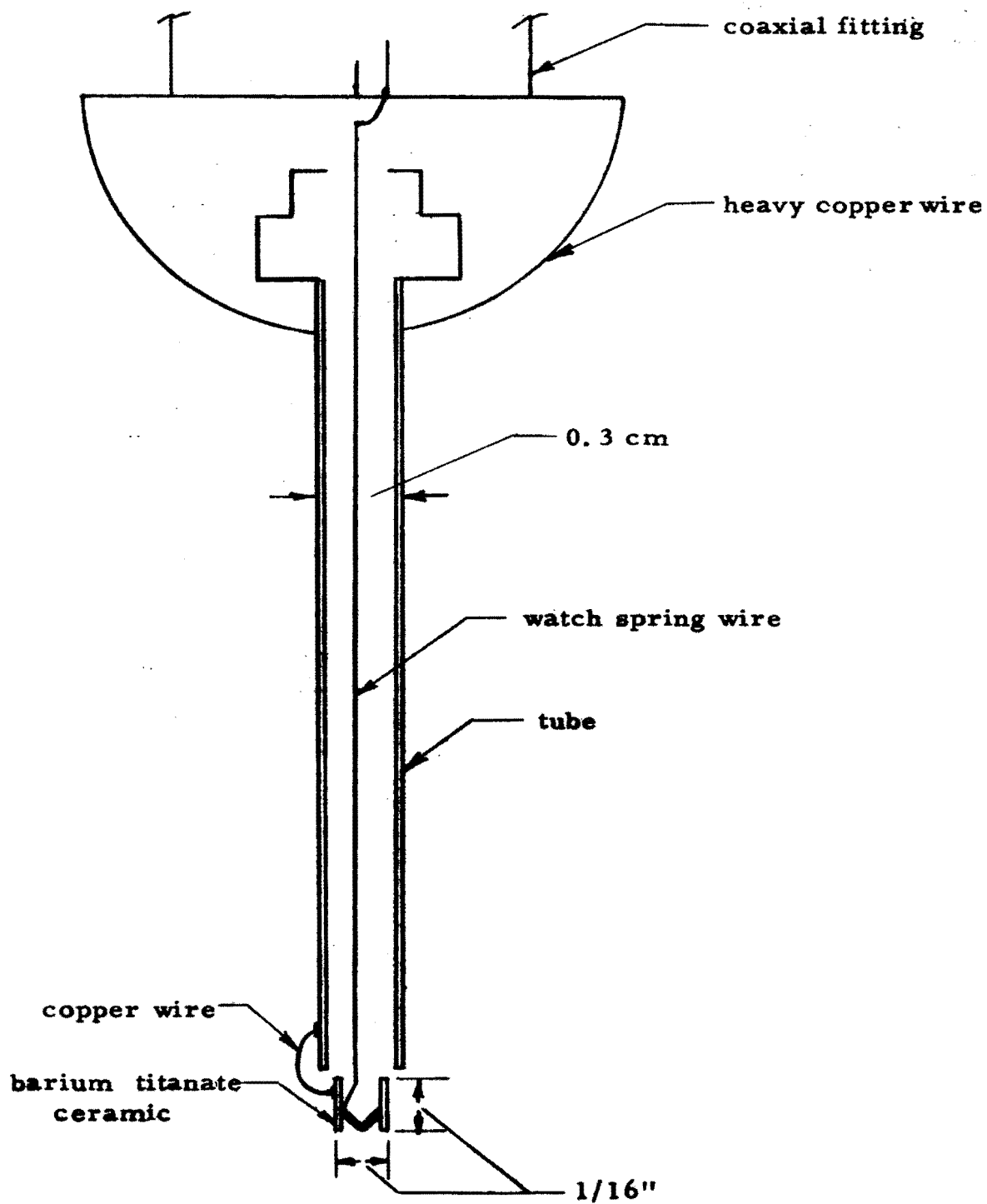

Figure 6

PROBE USED FOR READINGS

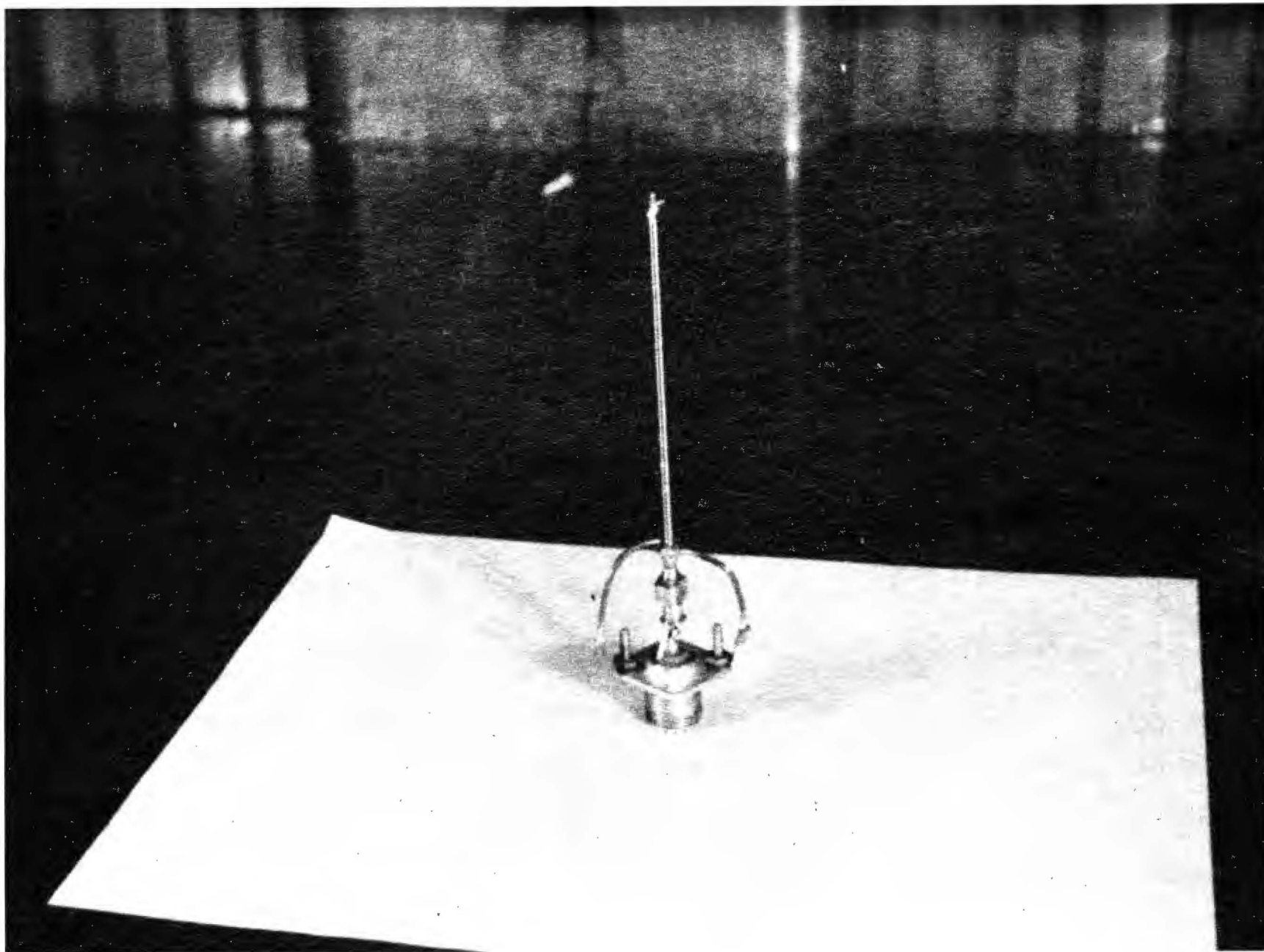

Figure 7

THE PROBE USED IN THE EXPERIMENT

Two turns of thin copper wire were wrapped around the outside surface of the ceramic cylinder. The copper wire was then soldered to the needle itself. No solder was used on the ceramic cylinder as it would be ruined by the heat.

The wire which extended down the center of the needle was soldered to the inside of a coaxial fitting. The needle was connected to the coaxial fitting by two copper wires and from the coaxial fitting, a coaxial cable led to the vacuum tube voltmeter. This probe worked in a satisfactory manner.

OSCILLATOR AND RESONANT CIRCUIT

Ultrasonic energy for the crystal oscillations was supplied to the crystal transducer by a radio frequency generator manufactured by the Ultrasonic Engineering Company of Maywood, Illinois. The circuit for the oscillator is shown in Figure 8.

This generator used two 304 TL vacuum tubes operated as a tickler feed-back oscillator. The fundamental resonant frequency of the crystal transducer controls the frequency. In this case, it is 490 kilocycles.

The radiation resistance of the crystal transducer is reflected into the plate tank circuit of the oscillator by link coupling. This link coupling then provides a mutual inductance between the oscillator plate tank circuit and the resonant circuit associated with the crystal transducer. The oscillator and the resonant circuit associated with the crystal are connected by means of a coaxial cable. A diagram for the resonant circuit is shown in Figure 9.

The tuned circuit as shown in Figure 9 associated with the crystal transducer is tuned to parallel resonance by the shunt capacitance of the shielded cable going to the crystal transducer and to the variable capacitor across it. In order to reduce the voltage drop across the tuning capacitor, and therefore, reduce the chance of arcing between the plates or to the ground, a fixed capacitor was placed in series with the variable capacitor.

Although a high Q and therefore a high L/C ratio is desirable in this tuned circuit, it was considered that the convenience of the tuning capacitor overshadowed the loss of Q caused by the extra capacitance.

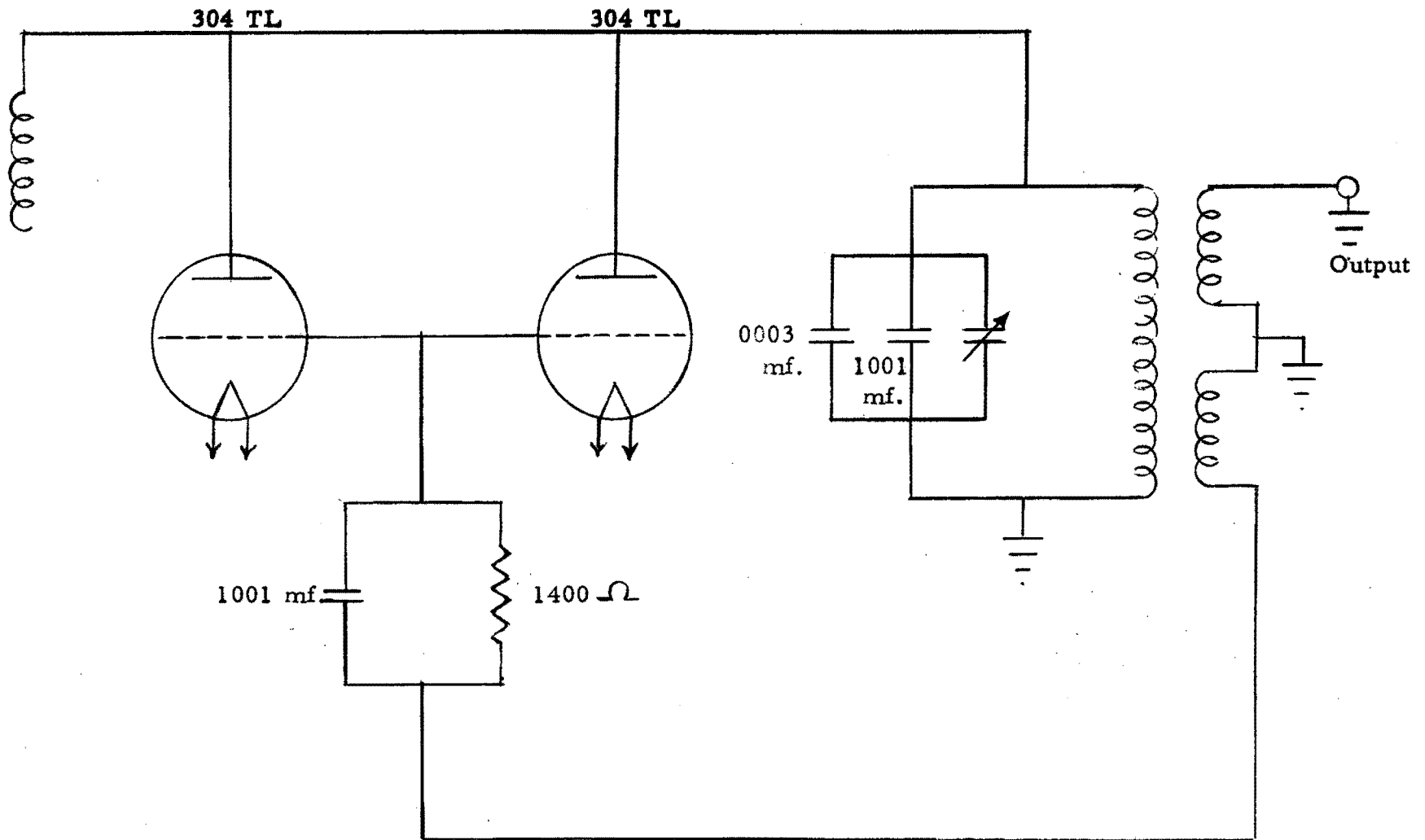

Figure 8

OSCILLATOR CIRCUIT

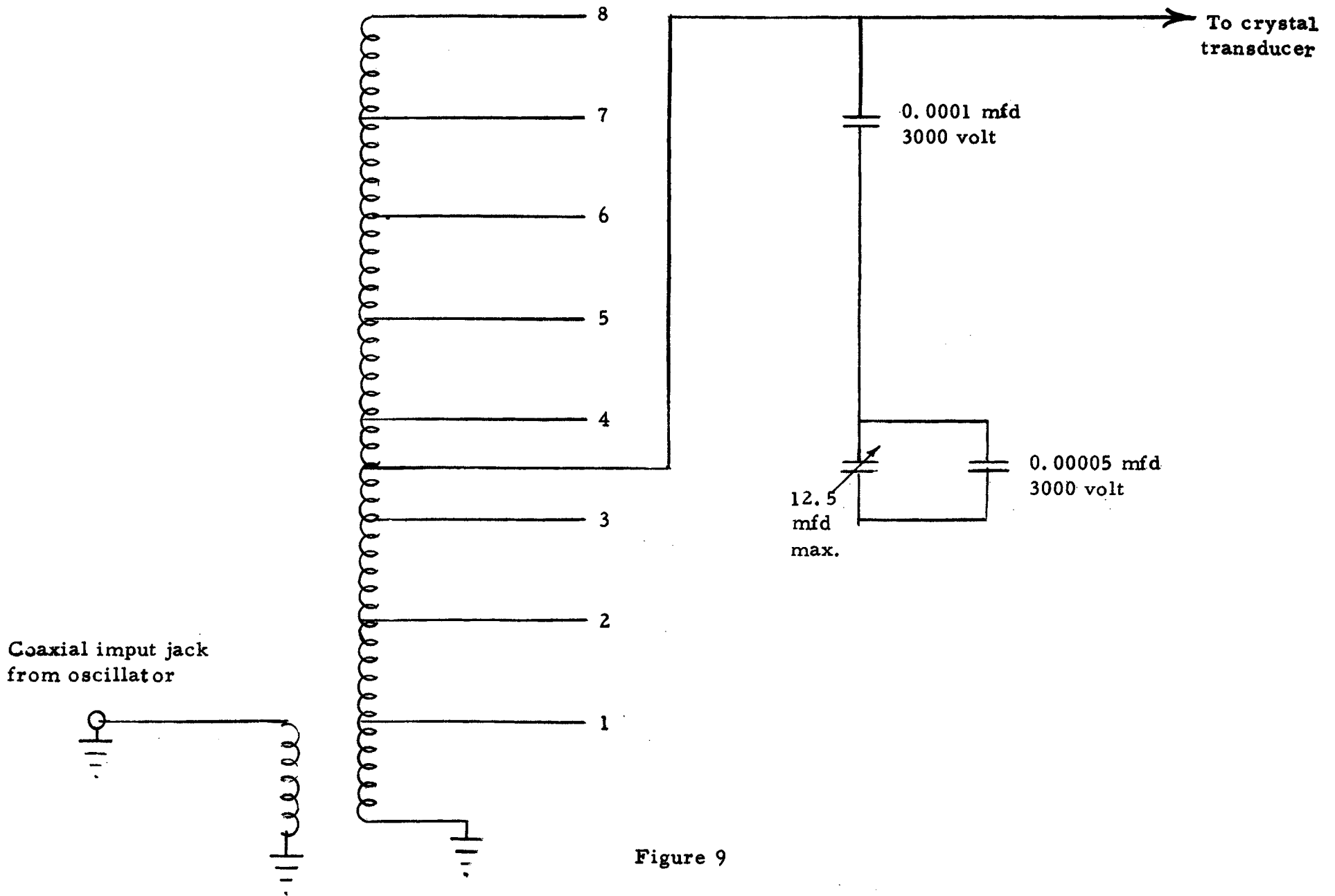

Figure 9

RESONANT CIRCUIT WITH CRYSTAL TRANSDUCER SHOWING TRANSFORMER, ETC.

Resonance was determined in the following manner. The transducer was placed in the oil in the tank and the radiometer was put in line with the transducer. Resonance was determined by varying the tuning capacitor until the maximum deflection of the radiometer was observed.

THE CRYSTAL HOLDER AND TANK

The crystal holder used was that from Breazeale's work* which was adapted from Carlin.**

The crystal holder shown in Figure 10 was designed to radiate the ultrasonic beam in a horizontal direction. The back of the holder was grounded and the front face was the high voltage side. The holder was held together by brass bolts. A small copper wire was attached to one of the bolts so that if an arc occurred between the parts of the holder, it would occur between the copper wire and the ground side and reduce the possibility of damaging the crystal. A plate of polystyrene was slipped over the backing cylinder and rested on flanges on the backing cylinder.

The high voltage lead of the coaxial cable was soldered to the front of the plate. The backing cylinder is hollow in order to increase the intensity of radiation in the forward direction. The entire holder was surrounded by a box which is described elsewhere in this paper.

The supporting rod of the crystal holder was mounted on a gear mechanism that gave the crystal holder movement with three degrees of freedom. This gear mechanism was mounted on two parallel rods which made it possible to move the crystal holder from one end of the tank to the other by means of a long threaded brass rod with a handle on the end.

*Breazeale, Mack, *The Velocity of Ultrasonics in Liquids*. Thesis, Missouri School of Mines, 1954, p. 24.

**Carlin, Benson, *Ultrasonics*. First edition. New York; McGraw-Hill Book Company, p. 105, 1949.

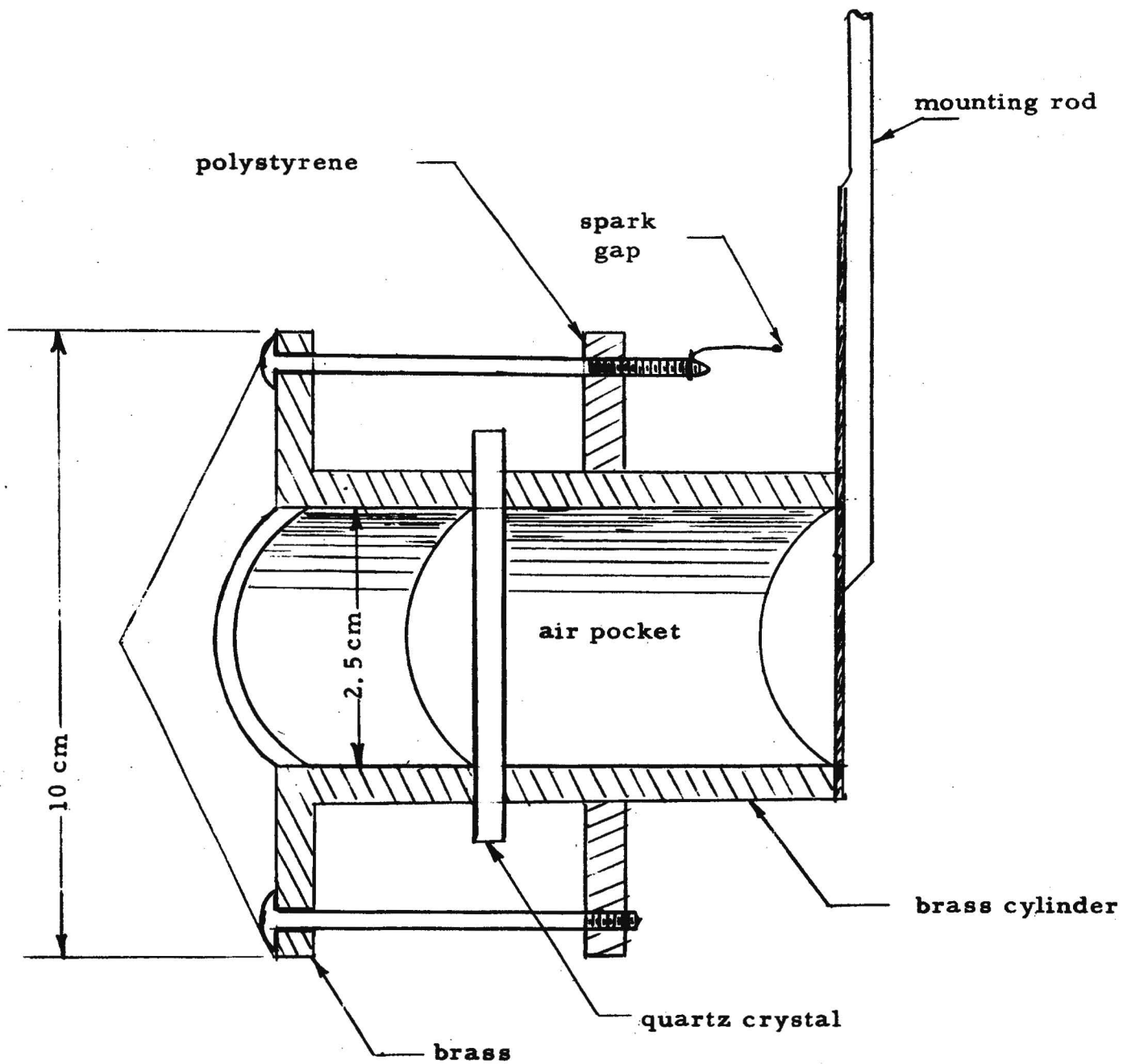

Figure 10

THE CRYSTAL HOLDER FOR RADIATING ULTRASONIC BEAM HORIZONTALLY

The dimensions of the tank itself were approximately 16 inches long by 6 inches wide and 9 inches deep. Masonite slabs covered with spun glass were put on the bottom, and three sides of the tank to reduce reflection to a minimum.

THE RADIOMETER

A calibrating device was necessary to use with the probe. A radiometer was designed and made, using ideas obtained from Vigoureux.*

When sound waves hit a plate, they are either wholly or partially absorbed or reflected, and they exert a pressure on the plate.

If waves of mean energy density E are normally incident on a plate which reflects a proportion γ and absorbs a proportion β of the energy, the pressure on the plate is equal to the difference between the energy densities on the two sides; that is $2(\gamma + \beta) E$. Thus, if the plate is a perfect reflector, β vanishes and γ is unity; hence the radiation pressure P_r equals $2E$. For this reason, the radiometer discs used in the oil were made of thin mica discs with a layer of air between, as almost perfect reflection is obtained from liquids to air.

The two mica discs were attached to a very light brass ring. The counter-weight used was another mica disc of the same construction and dimensions. The counter-weight was turned at a right angle with respect to the radiometer disc so that the chance of the ultrasonic beam impinging on the counter-weight was minimized. The radiometer is illustrated in Figures 11 and 12.

As shown in Figure 11, the two radiometer discs are attached to a

*Vigoureux, P., Ultrasonics. New York; John Wiley and Sons, Inc., 1951, pp. 73-74.

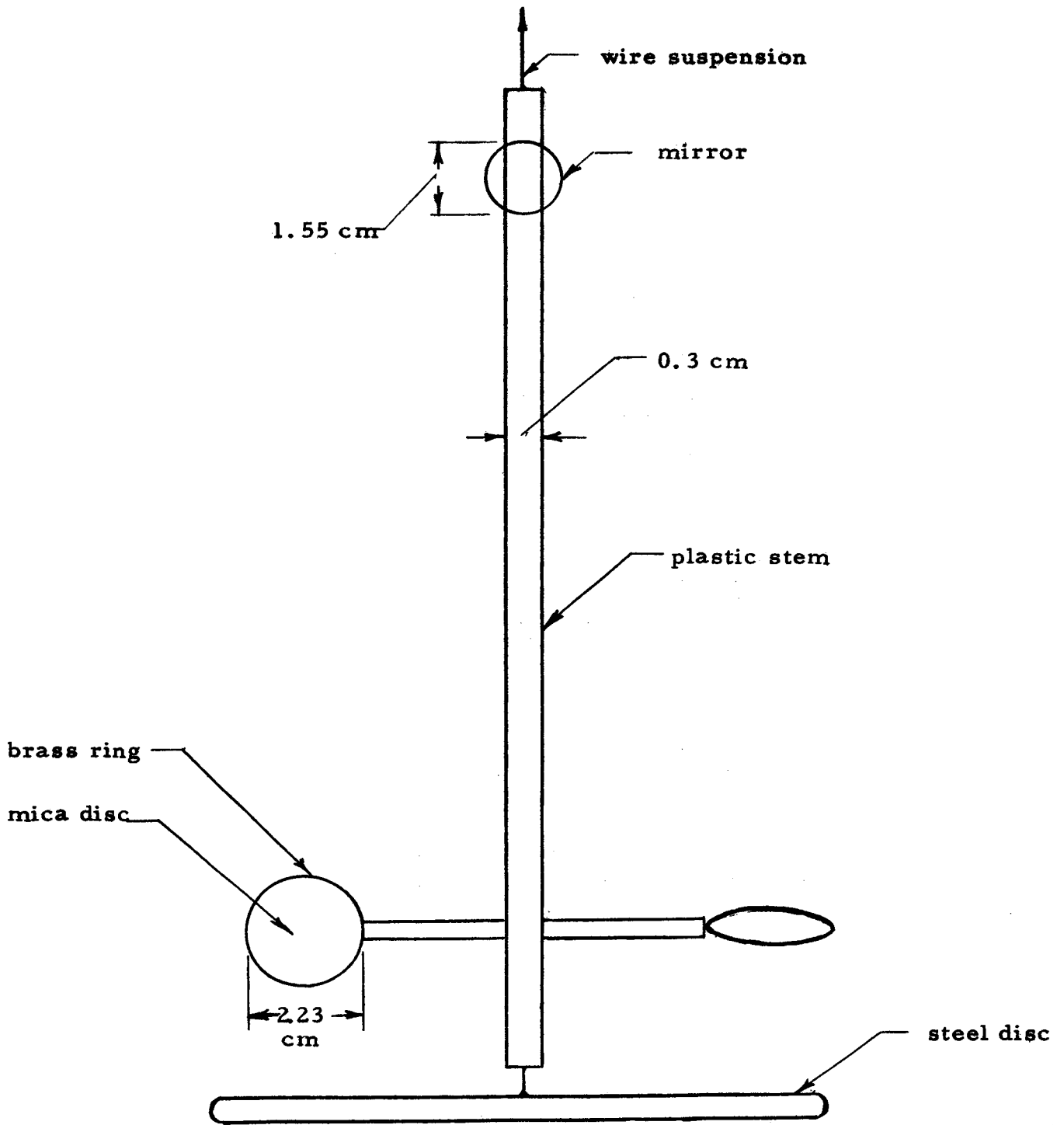

Figure 11

THE RADIOMETER

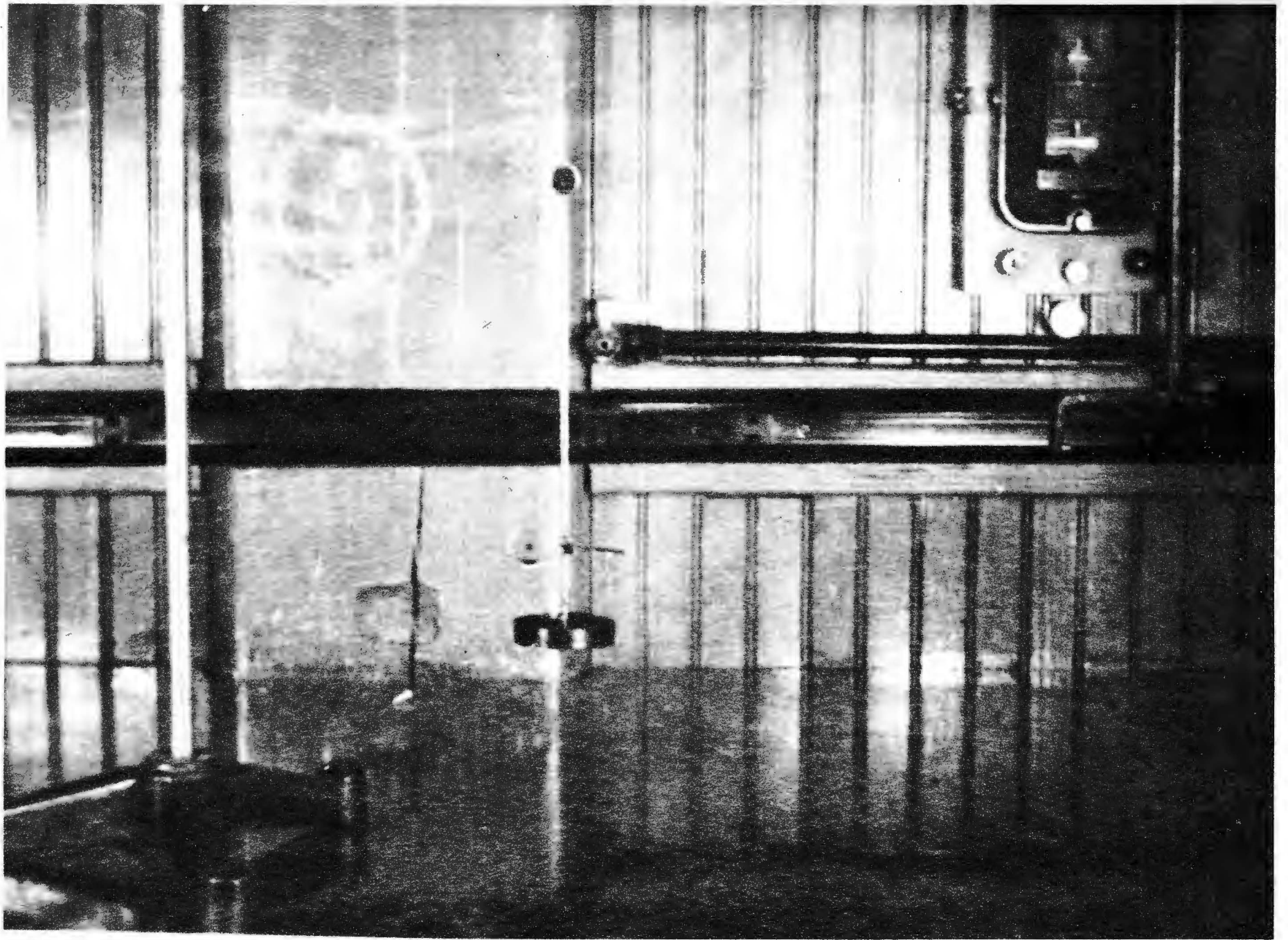

Figure 12

THE RADIOMETER USED IN THE EXPERIMENT

long plastic stem. The top of the stem is connected to a suspension wire. Near the top of the stem a small mirror is attached. A curved centimeter scale is placed 50 centimeters away from the mirror. A telescope is then focused on the image of the centimeter scale in the mirror.

When the ultrasonic wave impinges on the radiometer disc, the disc will be pushed back, twisting the radiometer and its suspension wire. The deflection of the centimeter scale as determined by the telescope is proportional to the twist of the suspension wire.

A heavy steel disc was attached to the bottom of the radiometer. This was necessary since the plastic rod and mica plates are so light that they would be forced out of position by the buoyant force of the oil. Also, the pressure of the ultrasonic wave was such that the radiometer would be displaced from its neutral position and would be pushed up in an arc similar to a ballistic pendulum.

The torsional constant of the suspension wire was determined by rotating the radiometer and heavy steel disc as a torsional pendulum and determining the period. Applying the torsional pendulum equation for the period gives:

$$T = 2\pi\sqrt{\frac{I}{\tau}} \quad \text{and} \quad \tau = \frac{4\pi^2 I}{T^2}$$

where: τ is the torsional constant in dyne - cm/radian.

T is period in seconds.

I is moment of inertia in gm - cm².

The moment of inertia of the system was calculated, using the heavy steel disc only, since it was approximately forty times the mass of the

radiometer. The axis of rotation was normal to the disc through the center. For this case $I = \frac{m r^2}{2}$.

The radiometer gives an indication of the radiation pressure at a point in the liquid, but Schaefer* established that the pressure on the plate is equal to the mean energy density in front of it.

According to Vigoureux,** intensity I is the energy crossing unit area in unit time and is equal to Ec where E is the energy density and c is the propagation velocity of the wave in the medium.

E is equal to $\frac{I}{c}$ and in terms of r. m. s. pressure, $E = \frac{p^2}{\rho c^2}$.

Where: p is the sound pressure.

ρ is the density of the medium.

c is the propagation velocity.

Solving for sound pressure p from this equation gives: $p^2 = \rho c^2 E$.

If the radiometer plate is a perfect reflector, the radiation pressure (P_r) = $2E$, so $E = \frac{P_r}{2}$. Substituting this value for E in the equation for sound pressure gives:

$$p = \sqrt{\frac{\rho c^2 P_r}{2}}$$

This is the equation that was used for computing the sound pressure when the radiation pressure, the density of the medium, and the propagation velocity were known.

*Schaefer, C., Zur Theorie des Schallstrahlungsdruckes.
Anal. Phys. Lpz. 35, p. 473, (1939).

**Vigoureux, Op. Cit., p. 74.

SCREENING

Since the output of the probe for the measurements taken was of the order of 100 millivolts or less, screening the receiving barium titanate and its circuit connections from the high frequency electromagnetic field of the transducer and oscillator was very important.

The oscillator and the resonant circuit of the crystal transducer were well shielded, since they were contained in metal cabinets.

The outlet from the resonant circuit to the transducer was surrounded by an aluminum plate.

The leads from the resonant circuit to the transducer were made into a type of coaxial cable. The high voltage lead was placed in a short piece of plastic water hose which was then enclosed in several layers of aluminum foil.

The shielding of the holder of the transducer is extremely important for this holder acts as an excellent antenna. The crystal holder was completely surrounded by a box made of Masonite. The outside surface of the Masonite was covered with aluminum foil.

A hole was bored in one side of the box to allow passage of the ultrasonic wave. The hole was covered with a small piece of bronze window screen. The screen served the purpose of shielding the high frequency electromagnetic field, but permitted the passage of the ultrasonic wave since the wire of the screen was small compared to the wave length of the ultrasonics. The shielding arrangement used for the crystal holder is illustrated in Figure 13.

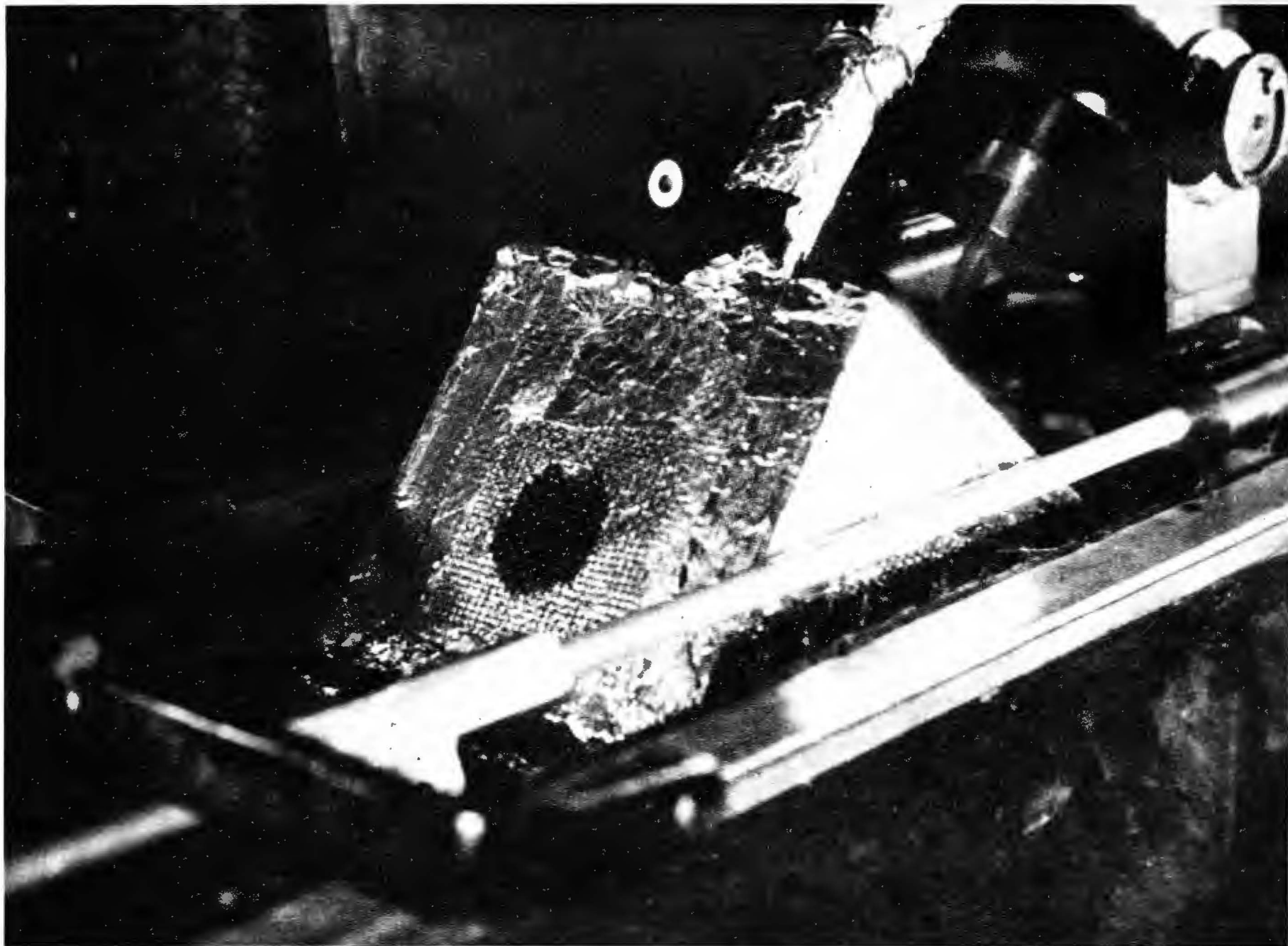

Figure 13

SHIELDING ARRANGEMENT USED FOR THE CRYSTAL
HOLDER SHOWING MASONITE BOX COVERED WITH ALUMINUM
FOIL, WIRE SCREEN, AND COAXIAL CABLE

The probe had a coaxial fitting at its base and coaxial cable from the fitting to the vacuum tube voltmeter. In addition, the oscillator, the resonant circuit, the crystal holder, and the vacuum tube voltmeter were all well grounded.

EXPERIMENTAL PROCEDURE

To calibrate the probe, it was necessary to determine the probe output voltage at a point in the oil and to measure the ultrasonic pressure at the same point.

As a preliminary step, the probe was introduced at various points in the tank in a direction perpendicular to the ultrasonic beam. It was discovered that the probe was extremely sensitive when brought close to the transducer and a very slight movement laterally across the beam caused a change of 20 to 30 millivolts in the probe output. However, when the probe was removed farther away from the transducer to the far end of the tank, a slight lateral movement caused very little change (about 5 millivolts) in the output voltage and for this reason, calibration readings were taken as far away from the transducer as possible. The ultrasonic beam spreads out as a cone from its source and, therefore, at the far end of the tank a lateral movement of the probe causes less change of probe voltage.

Readings were taken as follows: The radiometer was lowered into one end of the tank in line with the transducer. The plate current of the oscillator was set at 70 milliamperes and the maximum deflection of the radiometer was read by means of the mirror, telescope, and scale. The plate current was then turned up to 100, 120, and 150 milliamperes respectively, and readings were taken in a similar way.

The radiometer was then kept in the same position, but the transducer mechanism was moved back 0.5 centimeter and radiometer deflections

were again taken for plate current settings of 70, 100, 120, and 150 milliamperes respectively.

In order to secure a calibration, it was then necessary to place the probe in the same position as the radiometer. The horizontal distance of the probe and radiometer with respect to the transducer is not critical since the oil medium has a low absorption coefficient. It was important, however, that the probe be at the same position as the radiometer with respect to its transverse and vertical positions in the tank.

A small spot of metal layout ink was painted on the center of the radiometer disc. A mirror with a long handle (somewhat similar to that used by dentists) was lowered into the oil. The probe was then lowered into the oil and the ceramic crystal was centered in front of the radiometer spot by means of the mirror. The radiometer was then removed from the tank, leaving the probe in the correct position as far as the transverse and vertical position was concerned and within about 1 or 2 millimeters of the horizontal position that the radiometer held with respect to the transducer.

The plate current of the oscillator which controlled the intensity of the ultrasonic wave was then turned to 70, 100, 120, and 150 milliamperes respectively and probe output voltages were read on the vacuum tube voltmeter. Then the transducer was again moved back 0.5 centimeter and readings were repeated in a similar fashion.

A second series of readings were taken in the following manner: The radiometer was placed in the far end of the tank again, but this time it was placed as far off center with respect to the ultrasonic beam as the width of

the tank would permit. Its linear position with respect to the transducer was approximately the same, but no attempt was made to make it exactly so, as this was not desirable for good calibration. Readings for the radiometer and probe for this new setting were taken in exactly the same manner as before.

Figure 14 shows the experimental equipment with the metal enclosed resonant circuit, the vacuum tube voltmeter, the probe, and the tank containing the oil. In spite of careful shielding, there was a good chance that the probe output voltage was not due entirely to the piezoelectric action of the crystal. Always there is the possibility of the presence of the high frequency electromagnetic field.

To determine the amount of probe output that was due to the high frequency electromagnetic field, the following was done. A Masonite plate covered with a thick layer of rock wool was placed into the tank of oil between the transducer and the radiometer. The power was turned up to 150 milliamperes of plate current on the oscillator and no deflection was observed due to the motion of the radiometer device. This indicated that the rock wool plate was not permitting the passage of ultrasonic waves, which could be detected by the radiometer.

The probe was then lowered behind the rock wool plate and placed in several different positions and the power was varied from 20 milliamperes of plate current up to 150 milliamperes. The average probe output was on the order of 4 millivolts.

In order to map the ultrasonic field with the probe, readings were

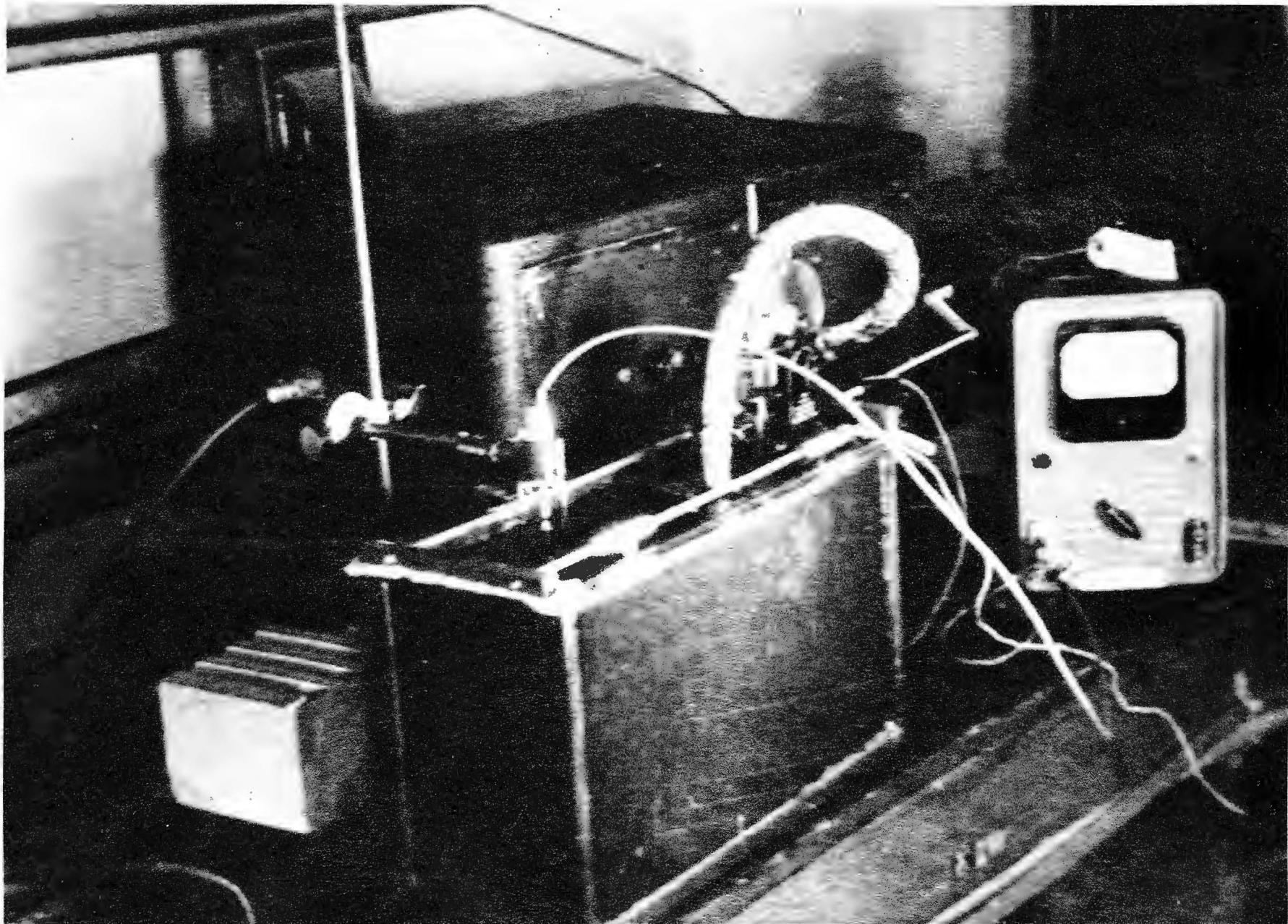

Figure 14

THE EXPERIMENTAL EQUIPMENT FOR
MEASUREMENTS WITH THE PROBE

taken in a plane perpendicular to the ultrasonic beam. The probe was placed at the center of the beam and then was moved horizontally off to one side and then the other at approximately 1/8 inch intervals. Readings of probe output were taken at these intervals. The probe was also moved up and down vertically in the same plane and readings taken.

DATA AND RESULTS

The data on the next two pages has the following meaning:

- a. The position of the transducer column indicates a reference point on a scale which was glued to the top of the tank.
- b. Readings were taken 0.5 centimeter apart for the various plate currents of the oscillator.
- c. Radiometer deflection is converted into radians.
- d. The radiation pressure is the pressure on the radiometer disc.
- e. Sound pressure is computed from the equation as developed in the radiometer section.
- f. The corrected probe reading is determined by subtracting the voltage that was due to the high frequency electromagnetic field. This background voltage amounted to 4 millivolts.
- g. With the radiometer and probe in the center of the ultrasonic beam, the average calibration for the probe is 0.225 microvolts/dyne/cm².
- h. With the radiometer and probe off toward the edge of the ultrasonic beam, the average calibration for the probe is 0.141 microvolts/dyne/cm².
- i. There is some difference between the two calibrations. The probe and radiometer were moved by hand and not being able to put them in the exact identical position causes error.
- j. On Page 41 is a polar distribution pattern of sound intensity for the ultrasonic field in the oil. The graph marked vertical is

Position of Transducer (cm)	Plate Current Milliamperes	Radiometer deflection (cm)	● (radians)	Radiation Pressure P_r ($\frac{\text{dynes}}{\text{cm}^2}$)	Sound Pressure p ($\frac{\text{dynes}}{\text{cm}^2}$)	Probe Millivolts		Calibration ($\frac{\text{Microvolts}}{\text{dyne/cm}^2}$)
						Observed	Corrected	
7 black	70	2.2	0.022	7.39	2.43×10^5	66	62	0.255
7.5 black	70	2.0	0.020	6.71	2.32×10^5	55	51	0.219
7 black	100	3.9	0.039	13.1	3.24×10^5	76	72	0.222
7.5 black	100	3.8	0.038	12.8	3.20×10^5	76	72	0.225
7 black	120	5.4	0.054	18.1	3.81×10^5	88	84	0.221
7.5 black	120	5.4	0.054	18.1	3.81×10^5	89	85	0.223
7 black	150	7.9	0.079	26.53	4.67×10^5	105	101	0.217
7.5 black	150	8.2	0.082	27.54	4.69×10^5	105	101	0.215

Radiometer and probe in center of the ultrasonic beam.

Approximate temperature = 30°C .

Position of Transducer (cm)	Plate Current Milliamperes	Radiometer deflection (cm)	Θ (radians)	Radiation Pressure P_r ($\frac{\text{dynes}}{\text{cm}^2}$)	Sound Pressure p ($\frac{\text{dynes}}{\text{cm}^2}$)	Probe Millivolts		Calibration ($\frac{\text{Microvolts}}{\text{dyne/cm}^2}$)
						Observed	Corrected	
7 black	70	1.3	0.013	4.51	1.9×10^5	32	28	0.147
7.5 black	70	1.3	0.013	4.51	1.9×10^5	31	27	0.142
7 black	100	2.3	0.023	7.97	2.53×10^5	44	40	0.158
7.5 black	100	2.3	0.023	7.97	2.53×10^5	40	36	0.142
7 black	120	3.3	0.033	11.44	3.02×10^5	48	44	0.146
7.5 black	120	3.3	0.033	11.44	3.02×10^5	45	41	0.132
7 black	150	5.0	0.050	17.33	3.72×10^5	54	50	0.134
7.5 black	150	5.1	0.051	17.65	3.76×10^5	52	48	0.128

Radiometer and probe off toward the edge of the ultrasonic beam.

Approximate temperature = 30° C.

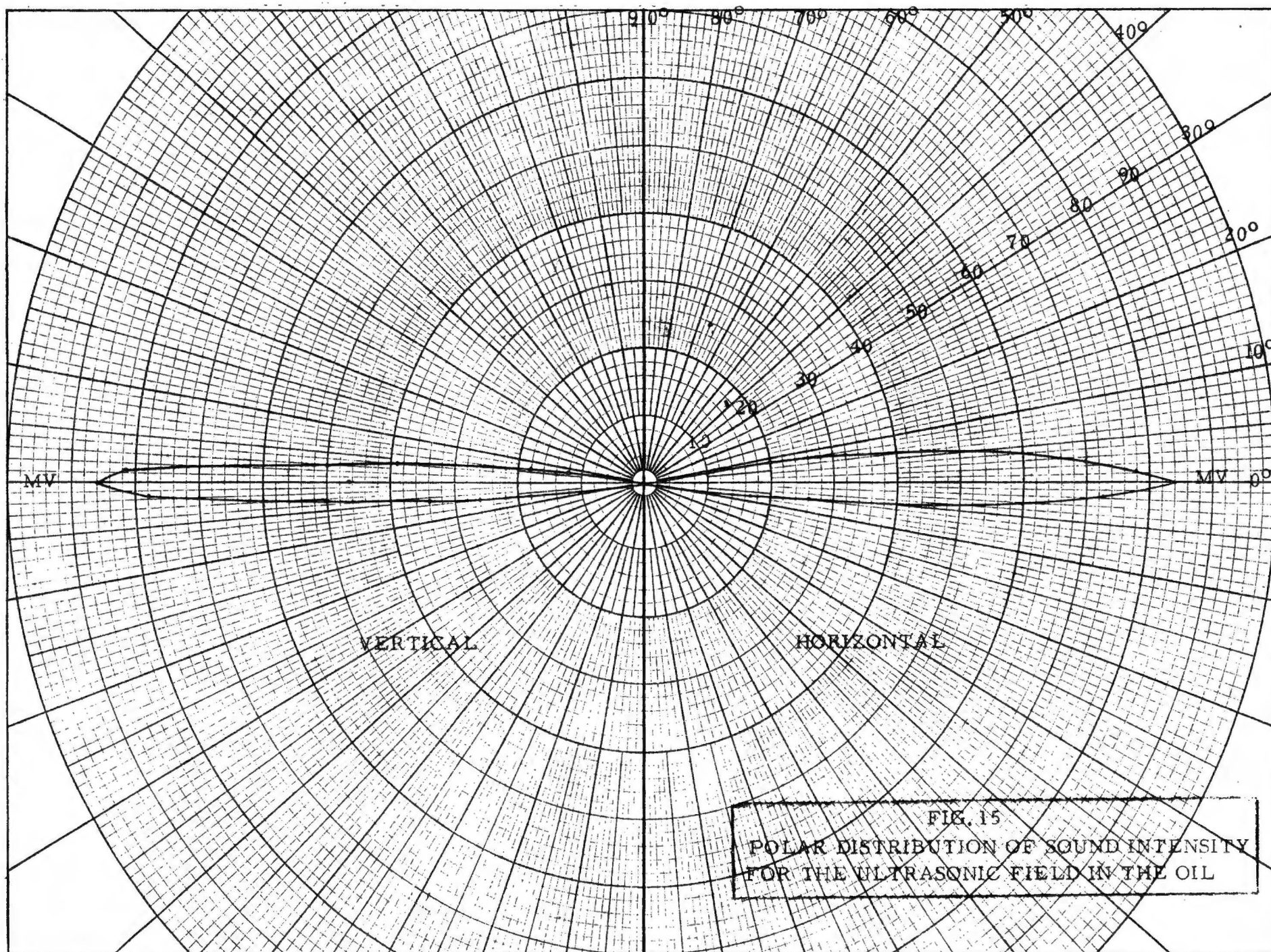

based on measurements which were taken by moving the probe up and down at points in a straight line in a plane and securing probe output readings for these points. The graph marked horizontal is based on measurements in the same plane, but taken at horizontal points in a straight line.

- k. The radius vector in the graphs represents probe output in millivolts which is proportional to intensity.
- l. The slit width from which the ultrasonic wave emerges is approximately one inch and the wave length of the ultrasonic wave is approximately 3 millimeters.
- m. These curves compare favorably to the usual polar distribution pattern for the case where the slit width is considerably greater than the wave length.

LIMITATIONS

The probe was calibrated for only one frequency (490 K. C.) and at room temperature.

The diameter of the probe needle used in this experiment was 3 millimeters. The diameter of the receiving crystal was approximately 1.6 millimeters. The probe should be small compared to the wave length of the ultrasonic wave in order to insure minimum disturbance of the field being measured. The wave length of the ultrasonic wave in the oil at a frequency of 490 kilocycles was approximately 3 millimeters.

The diameter of the radiometer disc should be large compared with the wave length. In this experiment, the diameter of the disc was approximately eight times the wave length.

The calibrating readings were done at low intensities, i. e., between 70 and 150 milliamperes of plate current. This was done to avoid cavitation which occurs at high intensities since the bubbles that are formed during cavitation may scatter and absorb some of the sound energy and would make measurements difficult and inaccurate.

RECOMMENDATIONS

A much larger tank (at least twice the length and width of the present tank) should be built. This will enable one to take data at more points in the oil medium to give a better probe calibration and a more definite picture of the field. Also, the possibility of reflection from the tank walls would be reduced.

A transducer of lower frequency should be used. A transmitter frequency on the order of 100 kilocycles would be quite suitable. This will increase the wave length by a factor of about five and thus increase the effectiveness of the present probe by making its dimensions small compared with the wave length.

The probe and radiometer should be put on a driving mechanism so that their position in the tank can be accurately determined to within 0.1 centimeter. This will increase the accuracy of the probe calibration and also enable one to secure an accurate plot of the ultrasonic field.

For intensity measurements with a piezoelectric probe, it is absolutely necessary that the high frequency electromagnetic field of the transmitter and oscillator be screened. Accordingly, the back plate of the crystal holder in the transmitting medium should be the high voltage side and the front plate should be grounded. The crystal holder serves as one large antenna. In so far as possible, the crystal holder should be made of non-conducting material.

CONCLUSIONS

It appears that the probe will serve as an excellent device for relative intensity measurements since there is a linear relationship between probe output and sound pressure.

The probe also is excellent for mapping of the ultrasonic field. When the probe is put in the center of the ultrasonic beam and then moved horizontally away from the center, there is a linear decrease in probe output. Also, when the probe is moved up and down vertically across the beam, there is a linear decrease in probe output as the distance from the center of the beam increases.

For situations where approximate pressures or intensities are desired, the probe will serve well. The average value for the calibrated probe is 0.183 microvolts/dyne/cm².

For measurements where absolute determination of ultrasonic pressure is desired, the probe would have to be recalibrated as stated in the recommendations.

APPENDIX A
MATERIALS

The insulating oil used in the tank was Westinghouse "Wemco C" obtained from Westinghouse Electric Supply Company in St. Louis, Missouri.

Dupont "Duco" cement was used to seal the mica to the radiometer disc and also to seal the absorbing material to the Masonite boards.

Ordinary aluminum "Reynolds Wrap" was used as a material in the coaxial cable.

The plates on which the absorbing material was placed were thin slabs of Masonite. The Masonite should be oil treated.

Glass wool was glued to the Masonite plates as an absorber. Rock wool was used on one of the plates and seemed to be a better absorber than the glass wool, and in addition, would not break loose and fall into the oil.

The wire used for suspending the radiometer in the oil was approximately 0.32 millimeter diameter Chromel-C as manufactured by the Hoskins Manufacturing Company, Detroit, Michigan.

BIBLIOGRAPHY

Books:

- Beranek, Leo L. Acoustic measurements. New York, John Wiley and Sons, 1949.
- Bergmann, Ludwig. Ultrasonics. New York, John Wiley and Sons, Inc., 1938.
- Carlin, Benson. Ultrasonic. First edition. New York, McGraw Hill Book Co., 1949.
- Randall, Robert H. An introduction to acoustics. Cambridge, Addison-Wesley Press.
- Richardson, E. G. Ultrasonic physics. Houston, Elsevier Publishing Co., 1952.
- Vigoureux, P. Ultrasonics. New York, John Wiley and Sons.
- Wood, A. B. A textbook of sound. London, G. Bell and Sons, Ltd.

Periodicals:

- Cady, W. G. and Gittings. On the measurement of power radiated from an acoustic source. J. Acoust. Soc. Am. 25, pp. 892, 896 (Sept. 1953)
- Greutzmacher, J. Piezoelektrischer kristall mit ultraschallkonvergenz. Z. Physics Vol. 96, p. 342 (1935)
- Hartmann, J and Mortensen, T. A comparison of the Rayleigh disk and the acoustic radiometer methods for the measurement of sound wave energy. Phil. Mag. (7) 39, p. 377 (1948)
- Hehlhans, F. W. Uber piezoquarzplatten als sender und emptanger hochfrequenter akustischer schwingungen. Anal. Phys. Lpz. IV Vol. 86, p. 587 (1928)
- Klein, E. Absolute sound intensity in liquids by spherical torsion pendula. J. Acoust. Soc. Am 9, pp. 372-320 (1938)
- Langevin, M. P. Sondage par le son spec. Publ. Intern Hydrogr Bureau Monaco No. 3, p. 34 (1924)

Richards, W. T. An intensity gauge for supersonic radiation in liquids. Proc. Nat. Acad. Sci., Wash. Vol. 15, p. 310 (1929)

Sacerdote, G. Microponi per ultrasoni. Acta Frequenza Vol. 2, p. 519 (1933)

Schaefer, C., Zur Theorie des Schallstrahlungsdruches.
Unpublished Material: Anal. Phys. Lpz. 35, p. 473, (1939).

Breazeale, Mack A. The velocity of ultrasonics in liquids. Thesis, Missouri School of Mines and Metallurgy, Rolla, Mo., 1954.

VITA

Robert F. Rohrer was born in St. Louis, Missouri, March 18, 1926. From 1940 until 1943 he attended Litchfield Community High School, Litchfield, Illinois. From 1943 to 1944 he attended Blewett High School, St. Louis, Missouri, and was graduated from this school in 1944. From 1944 until January, 1950, he attended Washington University, St. Louis, Missouri, and received a Bachelor of Arts degree in January, 1950.

From 1950 to 1954 he was a teacher in the Junior-Senior High School in Bonne Terre, Missouri. In September, 1954, he enrolled in the graduate division of the Missouri School of Mines and Metallurgy and was a graduate assistant in the Department of Physics.