

06 Apr 1995, 10:30 am - 12:30 pm

## Interaction of Adjacent Vibratory Machines

J. P. Lee

*Brown & Root, Inc., Houston, Texas*

J. A. Bohinsky

*Brown & Root, Inc., Houston, Texas*

Follow this and additional works at: <https://scholarsmine.mst.edu/icrageesd>



Part of the [Geotechnical Engineering Commons](#)

---

### Recommended Citation

Lee, J. P. and Bohinsky, J. A., "Interaction of Adjacent Vibratory Machines" (1995). *International Conferences on Recent Advances in Geotechnical Earthquake Engineering and Soil Dynamics*. 4. <https://scholarsmine.mst.edu/icrageesd/03icrageesd/session12/4>



This work is licensed under a [Creative Commons Attribution-Noncommercial-No Derivative Works 4.0 License](#).

This Article - Conference proceedings is brought to you for free and open access by Scholars' Mine. It has been accepted for inclusion in International Conferences on Recent Advances in Geotechnical Earthquake Engineering and Soil Dynamics by an authorized administrator of Scholars' Mine. This work is protected by U. S. Copyright Law. Unauthorized use including reproduction for redistribution requires the permission of the copyright holder. For more information, please contact [scholarsmine@mst.edu](mailto:scholarsmine@mst.edu).



## Interaction of Adjacent Vibratory Machines

Paper No. 12.14

J.P. Lee and J.A. Bohinsky  
Brown & Root, Inc., Houston, Texas

**SYNOPSIS** Due to inevitable unbalanced masses that always exist, a rotating machine will experience vibration to various extent depending on the characteristics of loads and support conditions. When two pieces of vibratory machines are installed close to each other, the vibration of either machine may further be amplified by the interaction between the two machines. In this paper, the interaction effect between two adjacent vibratory machines supported on a flexible floor was investigated. It was found that for the case investigated, the most critical condition occurred when the unbalanced forces were out-of-phase.

### INTRODUCTION

Due to imperfection of manufacturing, balancing, uneven thermal expansions, wear and tear after years of service, etc., a rotating or reciprocating machine is always subjected to dynamic unbalanced forces and vibrations even under normal operating conditions. The extent of vibration of a single machine supported on a flexible structure depends mainly on the magnitude and frequency of the excitation forces, as well as characteristics of the supporting structure (see for example Arya, 1981).

As a rotating or a reciprocating machine operates, the dynamic unbalanced forces are amplified, or attenuated, depending on the ratio of frequencies of the machine to the support system and the damping of the system. At or near the resonant condition, the amplification can be so significant that the vibration will cause discomfort to personnel around the machine area, compromising quality of products, and causing excessive maintenance cost. Therefore, in the design of a support structure for a vibratory machine, it is important to perform the frequency analysis to avoid a resonant condition and to perform a force-response analysis to assure that the vibration amplitude is within the allowable limit. Fortunately, the vibration amplitude can be minimized through carefully designing the stiffness and mass distribution of the support structure. The technique in determining the vibration amplitudes and designing the support structures to minimize vibrations has been published in many conference proceedings (Bohinsky, 1992).

When two pieces of vibratory machines are installed close to each other, the vibration problem gets more complicated. In addition to amplification or attenuation effect due to the flexibility of the machine support structure, the interaction effects between two adjacent vibratory machines need to be considered. The interaction may further amplify the responses of either machine's vibration.

In this paper, a case study was performed to evaluate the interaction effects of two adjacent variable speed rotating machines. The responses at bearing housings were obtained when the machines were subjected to first the in-phase and then the out-of-phase unbalanced loads. The results from both analyses were compared to evaluate the extent of the interaction effect.

### COMPUTER ANALYSIS MODEL

The problem to be investigated here concerns two identical rotating machines supported closely to each other on flexible floor. The elevated floor is constructed of concrete slab supported on steel I-beams. The computer analysis model utilized is shown in Fig. 1. The North direction, the center lines of the east and the west machine are also shown in the figure.

In this analysis model, the steel beams were represented by beam elements and the concrete floor was represented by finite elements. Fig. 2 shows the cross section A-A cut through the main girder (see Fig. 1). As can be seen in the figure, a built-up "T" is welded on top of the girder to provide the required rigidity. The metal decking is supported on wide flange beams. Fig. 3 shows the cross section B-B cut through the wide flange support beams (see also Fig. 1).

Since the stress levels of these members were generally low, uncracked section properties instead of transformed section properties were used. This is done to compensate for minute cracks that may exist in these concrete members.

The columns supporting the floor were well braced in both directions and provided relatively firm support, therefore, there was no need to include them in the model. However, the appropriate support condition was simulated and included in the model.

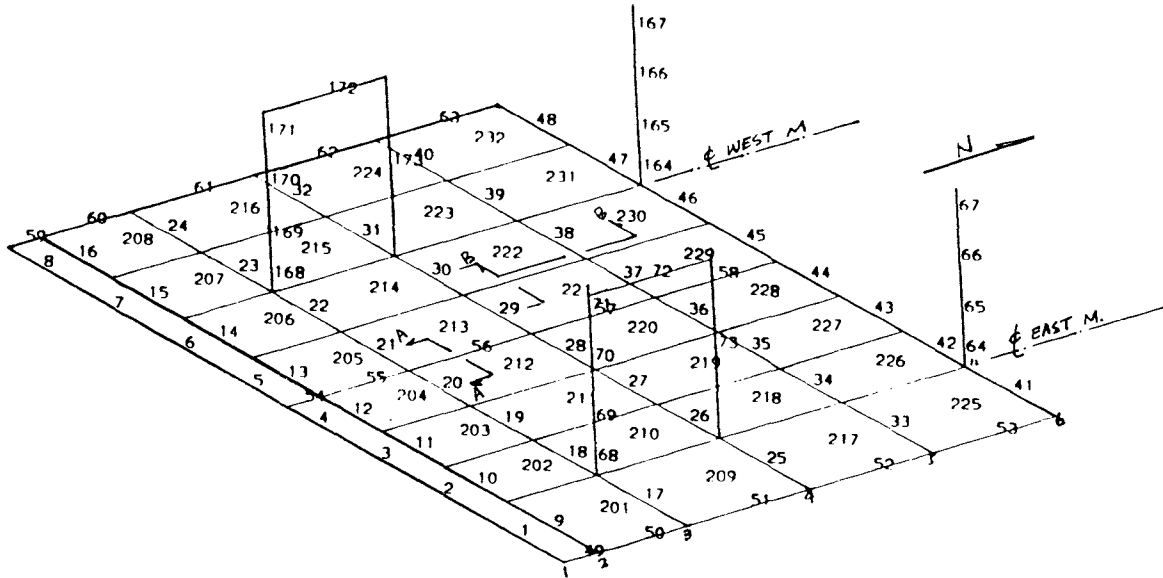

Fig. 1 Computer Analysis Model

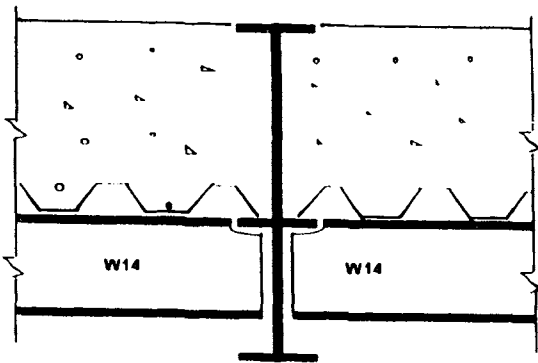

Fig. 2 Cross section A-A  
Cross Section Through Girder

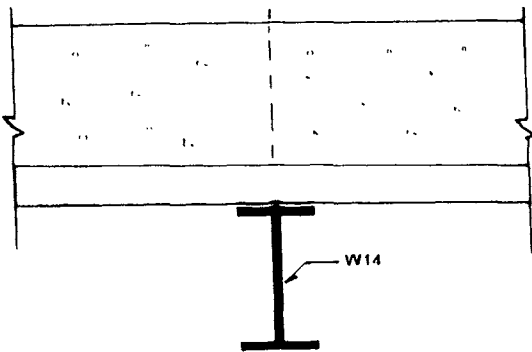

Fig. 3 Cross section B-B  
Cross Section Through Beam

#### FREQUENCY ANALYSIS

Using the model described above, a frequency analysis was performed to calculate the natural frequencies and mode shapes of the system. As mentioned earlier, the frequency analysis is a very important task in the design of vibratory machine foundation to avoid possible resonant condition. In addition, the mode shape can reveal relative rigidity of the support structure and provides very valuable insight for improving the structural design. By evaluating the mode shapes some "weak spots" can be detected and improved.

Fig. 4 shows a mode shape in the preliminary analysis. As can be seen, a particularly weak spot existed at the support beam under the outboard pedestal. The transverse displacement at the top of the pedestal is essentially due to the bending of the pedestal support beam rather than the bending of the pedestal itself. This beam was beefed-up and another frequency analysis was then performed on the improved structural system.

Three mode shapes are shown below in Figs. 5 through 7. Fig. 5 shows the rocking mode shape. An examination of this mode shape reveals that the transverse displacement at the top of the inboard pedestal is also essentially due to the bending of the support beams. Fig. 6 shows the significant vertical mode. The frequency of this mode can be increased by increasing the rigidity of the support beams under the machines. Fig. 7 shows the tilting mode in the direction along the shaft axis and is therefore not a major concern. Of course the true contribution of each mode to the overall displacement depends on its participation factor, frequency ratio and other factors.

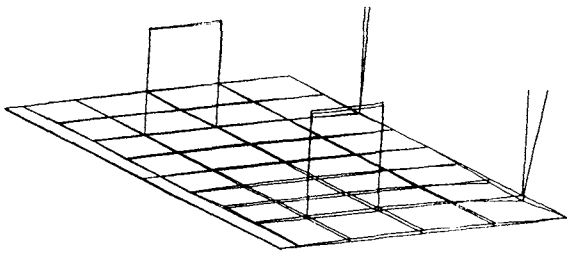

Fig. 4 Preliminary Mode Shape

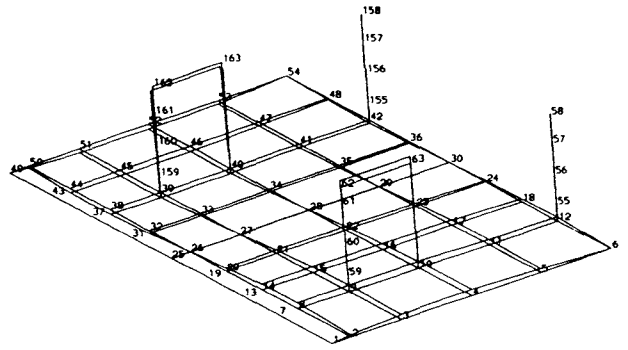

Fig. 6 Vertical Mode Shape

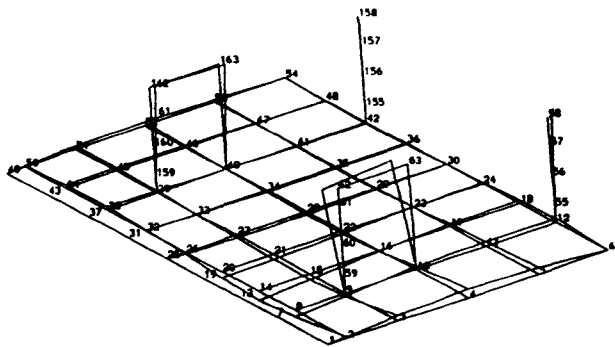

Fig. 5 Rocking Mode Shape

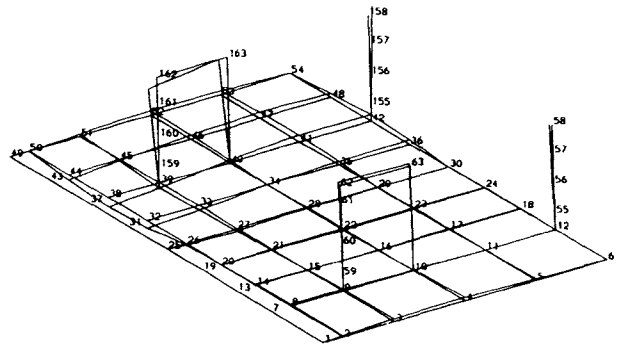

Fig. 7 Tilting Mode Shape

#### DYNAMIC UNBALANCED LOADS

The dynamic unbalanced force used in the analysis was 890 Pounds at a rotating speed of 900 revolutions per minute (RPM). Since the machines can operate at various speeds, the unbalanced forces at other speeds will vary and should be adjusted. The excitation forces at other operating speeds were adjusted according to the equation as shown below.

$$F = m * e * \omega$$

where:

- F = unbalanced force
- m = unbalanced mass
- e = eccentricity of unbalanced mass
- $\omega$  = circular frequency

The relationship between the operating speed  $f$  expressed in RPM and  $\omega$  is:

$$\omega = 2 * \pi * f / 60$$

#### FORCE-RESPONSE ANALYSIS

Using the model described above, a force-response analysis was performed using the computer program STRUDEL (ICES-STRUDEL, 1976). Since the excitation forces given by the manufacturer were sinusoidal in nature, harmonic analyses were performed; first assuming the forces on the two machines to be in-phase and then out-of-phase. Again, since these were variable speed machines, frequencies of the excitation forces were varied to cover the frequency range of interest. Sufficient modes were specified in the frequency calculation to assure that all significant modes were included in the modal combination. Furthermore, additional modes were added in separate sensitivity analyses to assure that differences between results with additional modes were insignificant.

#### COMPARISON OF RESULTS

The maximum responses including accelerations, velocities, and displacements at bearing housings were obtained for the in-phase and out-phase loading conditions. Since the velocity acceptance criteria is less sensitive to frequency, the velocity results are

presented here. Tables 1 and 2 show the maximum velocities for the in-phase and the out-of-phase cases respectively.

Table 1 Maximum velocities at Bearing Housings (In-Phase)

MACHINE ROTATING SPEED	EAST MACH. VELOCITY (IN,SEC)	WEST MACH. VELOCITY (IN,SEC)
650 RPM (10.84 Hz)	0.05	0.06
756 RPM (12.6 Hz)	0.03	0.03
890 RPM (14.83 Hz)	0.05	0.04
1000 RPM (16.67 Hz)	0.09	0.07

Table 2 Maximum velocities at Bearing Housings (Out-of-Phase)

MACHINE ROTATING SPEED	EAST MACH. VELOCITY (IN,SEC)	WEST MACH. VELOCITY (IN,SEC)
650 RPM (10.84 Hz)	0.02	0.02
756 RPM (12.6 Hz)	0.11	0.09
890 RPM (14.83 Hz)	0.05	0.04
1000 RPM (16.67 Hz)	0.09	0.07

#### DISCUSSIONS AND CONCLUSIONS

From the results as shown in Tables 1 & 2 and other sensitivity analysis results, it is clear that the interaction effect between the two variable speed machines is significant for this case. Neglecting the interaction effect between the two closely spaced machines would lead to unconservative results. It is interesting to note that for this case, the critical condition occurred when the excitation forces from the two machines were out-of-phase.

The degree of interaction of two closely spaced vibratory machines depends on many factors. However, a quick, preliminary assessment of this effect can be made by applying a load at the bearing housing of one machine. If the responses at the bearing housing of the other

machine are negligible, then the two machines are essentially decoupled and the interaction effect is small and can be neglected. For this case, the dynamic analysis of each machine can be performed separately.

On the other hand, if the responses at the other bearing housing are not negligible, the two machines are coupled and a dynamic analysis including both machines in the integrated model should be performed to include the interaction effect.

In the preliminary assessment, the applied load can be just a simple static load. Of course, the integrated model can be utilized in the dynamic analysis for either the coupled or the uncoupled case.

#### REFERENCES

- Arya, S. C., O'Neil, M. W., and Pincus, G., "Design of Structures and Foundations for Vibrating Machines", Gulf Publishing Co., 1981.
- Bohinsky, J. A., Lee, J. P., and Slabbaert, R. A., "Vibration of a Paper Machine Foundation", ASCE Tenth Structures Congress, San Antonio, 1992.
- Ohtmer, o., "ICES-STRUDL Application Manual", July, 1976.