

---

Masters Theses

Student Theses and Dissertations

---

1952

## Autographic determination of thermally-induced linear changes in ceramic bodies

William Dean McKee Jr.

Follow this and additional works at: [https://scholarsmine.mst.edu/masters\\_theses](https://scholarsmine.mst.edu/masters_theses)



Part of the [Ceramic Materials Commons](#)

Department:

---

### Recommended Citation

McKee, William Dean Jr., "Autographic determination of thermally-induced linear changes in ceramic bodies" (1952). *Masters Theses*. 2212.

[https://scholarsmine.mst.edu/masters\\_theses/2212](https://scholarsmine.mst.edu/masters_theses/2212)

This thesis is brought to you by Scholars' Mine, a service of the Missouri S&T Library and Learning Resources. This work is protected by U. S. Copyright Law. Unauthorized use including reproduction for redistribution requires the permission of the copyright holder. For more information, please contact [scholarsmine@mst.edu](mailto:scholarsmine@mst.edu).

AUTOGRAPHIC DETERMINATION OF  
THERMALLY - INDUCED LINEAR CHANGES  
IN CERAMIC BODIES

BY  
WILLIAM DEAN MCKEE, JR.

---

A  
THESIS  
submitted to the faculty of the  
SCHOOL OF MINES AND METALLURGY OF THE UNIVERSITY OF MISSOURI  
in partial fulfillment of the work required for the  
Degree of  
MASTER OF SCIENCE, CERAMIC ENGINEERING  
Rolla, Missouri  
1952

---

Approved by -

  
\_\_\_\_\_  
Professor of Ceramic Engineering

## CONTENTS

	PAGE
Acknowledgements.....	ii
List of Illustrations.....	v
List of Tables.....	vi
Introduction.....	1
Requirements.....	3
Review of Literature.....	5
Properties of Test Samples Affecting Requirements.....	5
Methods of Displacement-to-Voltage Conversion.....	7
Analysis of Displacement Conversion Elements.....	10
Converter Requirements.....	10
Electromagnetic Detector Elements.....	10
Resistance-Type Elements.....	11
Capacitance Conversion Elements.....	12
Design of a Capacitance Displacement Transducer.....	13
Means for Determining Capacitance Change.....	13
Means for Converting Frequency Change to Voltage.....	13
Final Design and Construction of Equipment.....	16
Design of Frequency to Voltage Converter.....	16
Design of Displacement-Controlled Oscillator.....	19
Experimental Results.....	31
Summary.....	35
Appendix A - Oscillator Calculations.....	36
Appendix B - Coupling Arm Calculations.....	37
Appendix C - Cathode Follower Calculations.....	39
Bibliography.....	40
Vita.....	42

## ACKNOWLEDGEMENTS

The author wishes to express appreciation to Dr. Paul G. Herold, Chairman of Ceramic Engineering who suggested the problem of this thesis, and who supervised and advised the author throughout the work.

Mr. B. M. Sedalia, who first used the furnace for which the author's equipment was designed, was of considerable assistance and provided the drawing which appears as Figure 1.

The Physics and Electrical Engineering Departments were generous with special tools, parts for experiments, and with test equipment. Professor Nolte of Electrical Engineering was particularly helpful.

Most of all, to his wife, Isabel, the author expresses most inadequately his gratitude for her patience, encouragement, and always willing help.

## LIST OF ILLUSTRATIONS

FIG.		PAGE
1.	Thermal Expansion Furnace.....	2
2.	Block Diagram of Superheterodyne Frequency- Voltage Function.....	15
3.	Graph of Typical Discriminator Frequency- Voltage Function.....	15
4.	Circuit Diagram of Superheterodyne Frequency- Voltage Converter.....	17
5.	Graph of Variation of Frequency as Function of Capacitor Rotation.....	21
6.	Method of Coupling Furnace Distance Piece to Oscillator.....	22
7.	Circuit Diagram of Displacement Controlled Oscillator.....	26
8.-10.	Photographs of Equipment.....	28-30
11.	Displacement Test Results.....	34

## LIST OF TABLES

TABLE		PAGE
I	Shrinkage-Expansion Values.....	6
II	Displacement Test Results.....	32

## INTRODUCTION

The determination of changes in length of ceramic compositions as a function of temperature is frequently required in ceramic research and testing. With the use of an observer, excellent means are available for determination of changes in length over moderate ranges of temperature. However, the extended period required for some tests makes desirable the automatic recording of length change as a function of temperature.

There has been in use in the Ceramic Engineering Department a furnace arranged for determination of length changes; this furnace, shown in Figure 1, is so arranged that change in sample length causes linear displacement of a refractory rod in contact with the test piece.

The temperature of this furnace is determined in the usual way by use of either a thermocouple or a radiation pyrometer.

For the purpose of recording changes in one variable as a function of another, there is available a Leeds and Northrup X-Y Recorder. This instrument consists of two self-balancing potentiometers so connected that change in one measured voltage moves a recording pen in a horizontal direction, while the other produces a vertical motion of the recording chart, thus recording one voltage as a function of the other.

The problem of this work has been to design and construct a device to permit the use of the X-Y Recorder for obtaining, automatically, a plot of change in length as a function of temperature, using the existing furnace and a standard thermocouple or radiation pyrometer for temperature-voltage conversion.

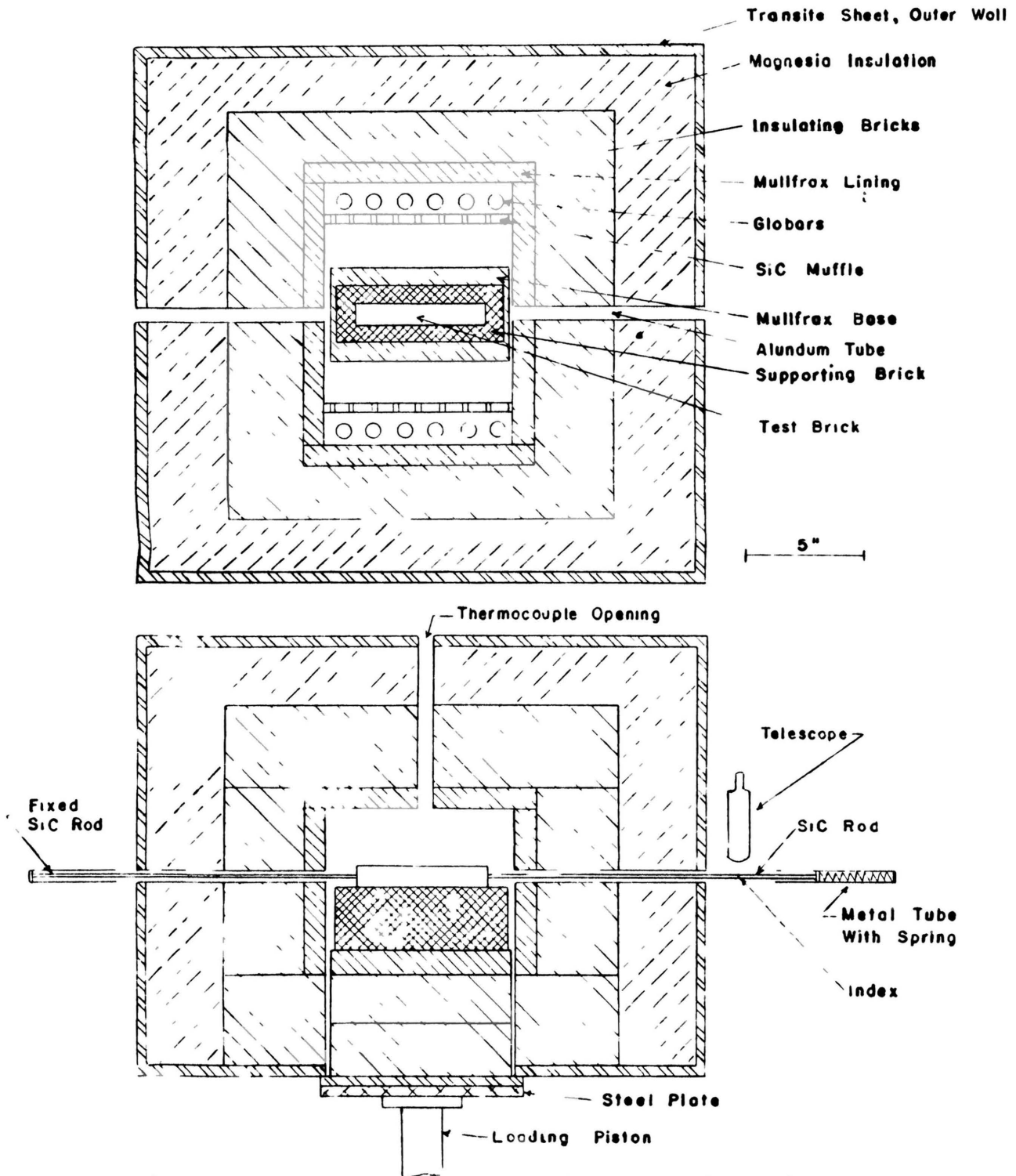

**Fig.1 Horizontal Section (top) and Vertical Section (bottom)  
of Thermal Expansion Furnace**



## REQUIREMENTS

The design of the displacement-to-voltage converter, or transducer, is affected by the characteristics of the recorder, the magnitude of the changes in length to be determined, the duration of tests, and other more general considerations. These requirements are stated as follows:

### I. Output requirements determined by recorder

Zero to 10 millivolts

### II. Linear Displacement Range

- A. The primary requirement is determination of the shrinkage, during initial firing, of a 6''x1''x1'' laboratory test sample, composed partially of unfired clay and of calcined clay.
- B. A secondary, though highly desirable requirement, is the determination of length changes incurred in reheating already fired ceramic bodies of the same laboratory size, 6''x1''x1''.
- C. It is desirable that an nearly as possible, full-scale deflection of the potentiometer be obtained. Since there are several ranges of total percentage change, it is indicated that the instrument must be essentially a multi-range displacement indicator, if full sensitivity is to be obtained.

### III. General Considerations

- A. The instrument should use a minimum number of non-standard parts; that is to say, as few parts as practicable should require special manufacture.

- B. Cost should be minimum, consistent with other requirements.
- C. The instrument should be simply operated, and require a minimum of attention during any operating period.
- D. Maximum adaptability to other types of furnaces is desired.

## REVIEW OF LITERATURE

## I. Properties of test samples affecting requirements

## A. Typical length changes of ceramic bodies on initial firing.

In a study of fire clays and shales used commercially for structural clay products, Meid and Hursh<sup>(1)</sup> found total firing shrinkage of approximately 6%. (It is worthy of note here that these tests were automatically recorded by means of a recording potentiometer for temperature, and an intervalometer-operated 16mm movie camera, used to record time as indicated by a watch and the expansion indicated by an Ames dial micrometer; this arrangement provided a record, but no graph of the data). In a similar series of tests, Van der Beck and Everhart<sup>(2)</sup> also found total shrinkages of approximately six percent.

In a study of materials for high-alumina refractory brick, Sedalia<sup>(3)</sup> measured firing shrinkages of as much as 16% on raw bauxite bars, and on his heavily grogged bodies, total shrinkage and/or expansion during firing of 0.8%.

In a study of materials for silica brick, Shulze<sup>(4)</sup> found maximum expansions on firing silica brick of from 5.5% to 6%.

Stevens and Birch<sup>(5)</sup> found linear changes of +1% to -9% in a study of firing behavior of fire-clay refractories.

- 
- (1) Meid, W. J. and Hursh, R. D., Effects of Heating Rate on Shrinkage of Clays and Shales in Firing, Jour. Amer. Cer. Soc., 34, 9, p. 287, (September 1951)
- (2) Van der Beck, R. R. and Everhart, J. O., Firing and Cooling Shrinkage Behavior of Structural Clay Bodies, Jour. Amer. Cer. Soc., p. 361, 34, (December 1951)
- (3) Sedalia, B. M., Bauxite vs Diaspore Clay in High Alumina Refractory Brick, Thesis, Missouri School of Mines, 1951
- (4) Shulze, C. E., personal communication.
- (5) Stevens, D. K., and Birch, R. E., Shrinkage Rates in Firing Fire-Clay Refractories, Jour. Amer. Cer. Soc., 30, (12), pp. 102-13 (1947)

**B. Typical behavior on reheating previously fired bodies:**

The reheat behavior of fired ceramics is of considerable interest, principally in regard to refractory materials. Norton's<sup>(6)</sup> studies of the expansion-shrinkage characteristics of fired refractories may be regarded as typical, at least in so far as concerns the total amounts of length change to be expected. He found maximum expansions in the temperature range 50° - 1600°, of from 0.1% to 0.2%, to as much as 5%, with all but one clay brick less than 1%, and nearly all others less than 2%. Also shrinkage of as much as 0.3% was encountered in the same temperature range.

**C. Summary of displacement ranges:**

The following table of changes in length can be made on the basis of the types of samples to be handled. Linear changes are based on a 6" sample.

TABLE I

<u>TYPE SAMPLE</u>	<u>MAXIMUM % SHRINKAGE</u>	<u>MAXIMUM % EXPANSION</u>	<u>TOTAL % RANGE</u>	<u>DISPLACEMENT INCHES</u>	<u>RANGE TOTAL CM</u>
Raw clay or Bauxite	16%	1%	17%	.96	2.4
High-Shrinkage Unfired Clay Bodies	8%	2%	10%	.6	1.52
Low-Shrinkage Unfired Clay Bodies	2%	3%	5%	.3	.76
Fired refractories-Group I*	.1%	1.0%	1.1%	.066	.167
Fired refractories-Group II*	.2%	5%	5.2%	.312	.793

\* Grouping is arbitrary on basis of observed results

(6) Norton, F. H., Refractories, 3rd Edition, pp. 482-85, McGraw-Hill Book Company, New York, 1949

If all types of bodies are to be handled, with a large portion of the potentiometer scale used, the linear displacement converter will require four ranges. Omission of a range for high shrinkage clays could be tolerated, since determinations on high shrinkage clays are not often required.

It would appear, then, that the instrument should be arranged for the three other ranges. However, it should be pointed out that the expansion-shrinkage characteristics of a sample are initially unknown, making impractical maximum-sensitivity ranges except possibly for exact work preliminary runs. Therefore, it was determined that the following ranges should be handled, with the initial point at 5 millivolts on the potentiometer scale: Plus or minus 10% =  $\pm .3''$ , and plus or minus 2% =  $\pm .12''$ .

## II. Methods of Displacement-to-Voltage Conversion

There are a great number of ways in which a linear displacement can be used to produce a change in voltage directly, or to produce a change in some electrical parameter of an electric or electronic circuit. Most of these methods are listed by Batcher and Moulie<sup>(7)</sup>. Only those listed by these authors with a range of operation "micro-inches to inches" are of interest for this application. These changes by displacement are:

- A. Variation of reluctance of a magnetic gap altering generated voltage.
- B. Variation of reluctance of magnetic gap altering inductance.
- C. Change in resistance of a variable resistance.

---

(7) Batcher, R. R. and Moulie, William, The Electronic Control Handbook, p. 32, Caldwell-Clements, Inc., New York, 1946

D. Alteration of reactance of a variable capacitor.

Only a few references for these are believed necessary, since a number of displacement indicators have been made using each of these types of so-called "displacement variable". Batcher, and Moulic<sup>(8)</sup> cite a number of examples and applications. An example of the first type, variation of generated voltage by variation of the reluctance of a magnetic circuit, is provided by the electric gage of Brown<sup>(9)</sup>.

In this instrument, the displacement to be measured moves an armature modifying the e.m.f. of two differentially connected transformers. The output, of course, was alternating current. The particular instrument described had a useful range of .002 inches, but the principle is adaptable to greater ranges.

Rusher's<sup>(10)</sup> thickness gage utilizes the effect on inductance of change in the proximity of a magnetic material. A somewhat similar method is that of Gordon and Richmond<sup>(11)</sup>, which uses the effect on inductance of the change in proximity of a sheet of conducting material.

Practical use of change in resistance for determination of small displacements requires the use of some mechanical means for amplifying the displacement. This was accomplished by Coyle and Haynes<sup>(12)</sup>, who converted an ordinary dial micrometer gage to a micro-potentiometer, using the indicator arm as the moving contact for an added circular resistance. Similar modification is facilitated by the "Micro Potent-

(8) Batcher, R. R. and Moulic, William, Op. cit., Sec. II, Chapter I.

(9) Brown, E. B., Two Useful Electromagnetic Gauges, Jour. Sci. Instr. Vol. XXV, p. 41, 1948.

(10) Risher, M. A., Enamel Thickness Gage, Bull. Amer. Cer. Soc., 14, (11) 356-67, (1935)

(11) Gordon, C. C. and Richmond, F. C., A Thickness Gauge for Ceramic Coatings, Jour. Amer. Cer. Soc., 33, (10), 295-300, (1950)

(12) Coyle, M. B., and Haynes, F. G., A Remote Reading Dial Micrometer, Jour. Sci. Instr., 25, (8), 275-6, 1948.

imeter'', a commercial device specifically designed for application to dial gages. An application of this device is described by Scarlett and Robertson<sup>(13)</sup>.

Possibly one of the earliest applications of the electron-tube oscillator to determination of small displacements was the ''Ultra-micrometer'' of Whiddington<sup>(14)</sup>, who made a capacitance micrometer, using change in capacitance to vary the oscillation frequency of an inductance-capacitance oscillator. Change in frequency was detected by a heterodyne method. Sensitivity claimed was  $10^{-8}$  cm. (This was essentially an experimental device).

Dayton and Foley<sup>(15)</sup> described a capacitance micrometer method used for dilatometry and other purposes, in which a displacement changed a capacitance, causing frequency modulation of an oscillator; detection of the change in frequency was made by a discriminator producing a d-c output.

Another capacitance micrometer was that of Prytherch<sup>(16)</sup>, in which the capacitance was inserted in the series grid circuit of an electron tube oscillator, thereby permitting measuring of the resultant change in plate current.

- 
- (13) Scarlett, J. A., and Robertson, V. A., An Automatic Apparatus for Testing Refractories Under Tensile and Compressive Loads at High Temperatures, Jour. Amer. Cer. Soc., 34, (11), 348-53, (1951)
- (14) Whiddington, R., The Ultramicrometer, Phil. Mag., 40, No. 239, November 1920.
- (15) Dayton, R. W., and Foley G. M., Capacitance Micrometer, Electronics, 19, (9), 106-11, (1946)
- (16) Prytherch, W. E., A New Form of Dilatometer, Jour. Sci. Instr., 2, 128, (1932)

## ANALYSIS OF DISPLACEMENT CONVERSION ELEMENTS

In order to determine the most suitable displacement conversion element, it may be well to restate the requirements of the element:

### I. Converter Requirements

- A. Output must be in range 0-10 millivolts
- B. Complete equipment should indicate plus or minus expansions of 10%, 5%, and 2% all on the basis of a 6'' bar. Change in range should be quickly and easily accomplished.
- C. Change in voltage output must be proportional to linear displacement in order to obtain, on the X-Y Recorder, a graph requiring no re-plotting.
- D. Displacement-to-voltage converter should use a minimum of specially fabricated components.
- E. The equipment should be easily adaptable to displacement-measuring applications other than the furnace for which designed.

### II. Electromagnetic Detector Elements

Some types of these can be eliminated immediately since no simple method can be found to produce a voltage change proportional to displacement.

The one type giving output proportional to displacement is fairly difficult to construct. Commercial models are available, but are expensive; in addition, they are not easily adapted to other applications, and since the output is alternating current, require rectification for use with a direct current potentiometer. For these reasons, the other



types of displacement-detectors are preferred.

### III. Resistance-Type Conversion Element

In some respects, the resistance-type conversion element, consisting of a dial micrometer - micro potentiometer combination, is an ideal solution. Definite advantages are:

- A. Very simple electrical circuit, and output can be connected directly to recording potentiometer.
- B. Use with a dial-micrometer provides a visual check on the recorder, and two points of visual displacement observation.
- C. Because resistances in series add directly, the resistance change method is applicable to "both-ends" determinations of linear change. By this is meant the use of distance pieces at each end of a large sample.

The method does have disadvantages:

- A. The "Microtorque" potentiometer is expensive (about \$65) for the jeweled type for use with a dial micrometer<sup>(17)</sup>.
- B. The displacement range is limited to that of a single revolution of the dial gage, unless a mechanical reduction linkage is provided, which increases the possibility of error. This would require a different dial gage for each range covered.
- C. The manufacturer claims an accuracy of only 6% of the total resistance of the potentiometer. This is sufficient to cause serious error at small displacements, and tends to produce anomalous results at inflection points.

Despite the disadvantages, use of a dial-micrometer-potentiometer combination is an excellent solution to the problem of recording only  
<sup>(17)</sup> Commercial Literature, G. N. Giannini Company

one range of displacements.

#### IV. Capacitance Conversion Element

The capacitance variation of an air dielectric, parallel-plate capacitor is proportional to the area of one plate, and inversely proportional to the separation between plates. These linear relationships make capacitors well suited for displacement indication, since several means are available for producing a voltage proportional to the change in capacitance. Other advantages are:

- A. Variable capacitors, of the rotary type, are readily available commercially. For some special applications, special variable capacitors are easily fabricated.
- B. The electronic equipment necessary for conversion of capacitance change to voltage change is constructed of standard radio parts.
- C. Several displacement ranges can be covered by proper equipment design. Change from one range to another usually requires only manipulation of switches.

The principal disadvantages are:

- A. Use of a rotary variable capacitor requires mechanical conversion of linear displacement to rotation.
- B. The additional electronic equipment required must be specially designed for the ranges to be covered.

It was considered that for multirange operation, the capacitor conversion element would be most advantageous. The balance of this paper covers the design and test of a capacitance conversion element and necessary associated equipment.

## DESIGN OF A CAPACITANCE DISPLACEMENT TRANSDUCER

### I. Means of Determining Capacitance Change

One of the ways of determining a small change of capacitance is to vary the resonant frequency of an inductance-capacitance tuned radio frequency oscillator. Determination is then made of change in frequency, and if other circuit constants are known, the actual change in capacitance can be determined.

In this application, instead of actually determining capacitance change, the change in frequency is converted to a proportional voltage used to actuate the displacement variable of the X-Y Recorder. The operations then become:

- A. Displacement produces proportional angular rotation of capacitor.
- B. Rotation of capacitor produces proportional frequency change.
- C. X-Y Recorder follows e.m.f.

### II. Means for Converting Frequency Change to Voltage

A. Heterodyne and audio-frequency counter circuit: this combination would use another fixed oscillator of proper frequency to produce <sup>(18)</sup> an audio-frequency 'beat-note', and a detector, followed by an audio-frequency meter of the type described by Batcher and Moulic <sup>(19)</sup>. Construction of a similar meter is described by Turner <sup>(20)</sup>.

<sup>(18)</sup> For beat oscillator examples, see F. E. Terman, Radio Engineering, McGraw Hill, 1947.

<sup>(19)</sup> Batcher and Moulic, op. cit., p. 201

<sup>(20)</sup> Turner, R. P., A Direct Reading Electronic Audio Frequency Meter, Radio and Telev. News, 45, (2), p. 54, (February 1951)

### B. Frequency discriminator

Reference was made previously to the use by Dayton and Foley<sup>(21)</sup> of a frequency-discriminator of the Foster-Seeley type. Two different forms were described as follows:

1. With the discriminator working at displacement-oscillator frequency.
2. In a superheterodyne circuit, in which the displacement oscillator frequency is converted to the discriminator frequency.

The latter arrangement is much more versatile in that the displacement-controlled oscillator can be made to operate on the most convenient frequency without regard to the discriminator frequency. If desired, the control oscillator may operate on a different frequency for each different range; alternatively, several oscillators of different frequencies can be operated into the same recorder.

A block diagram of the superheterodyne arrangement is presented as Figure 2. A typical voltage-frequency function for a discriminator is plotted as Figure 3.

This arrangement was thought superior to the audio-frequency meter type of frequency-to-voltage detector, since a major portion of the circuit follows standard radio receiver design, doubly advantageous from the standpoint of design and construction, and from that of component parts.

---

(21) Dayton and Foley, op. cit.

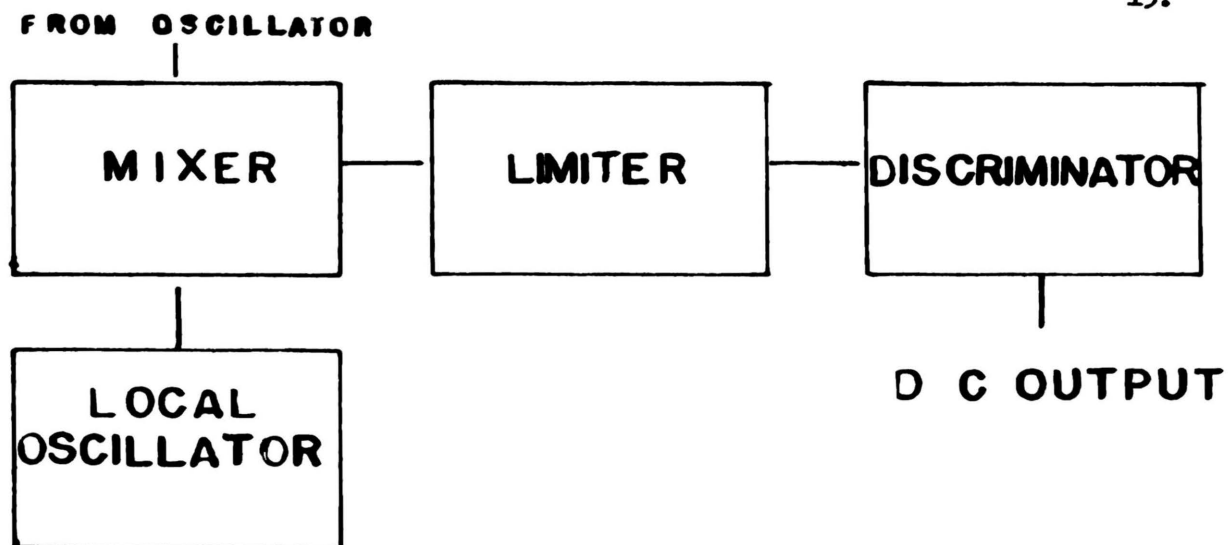

Fig.2 BlockDiagram of Superhetrodyne  
Frequency -Voltage Converter

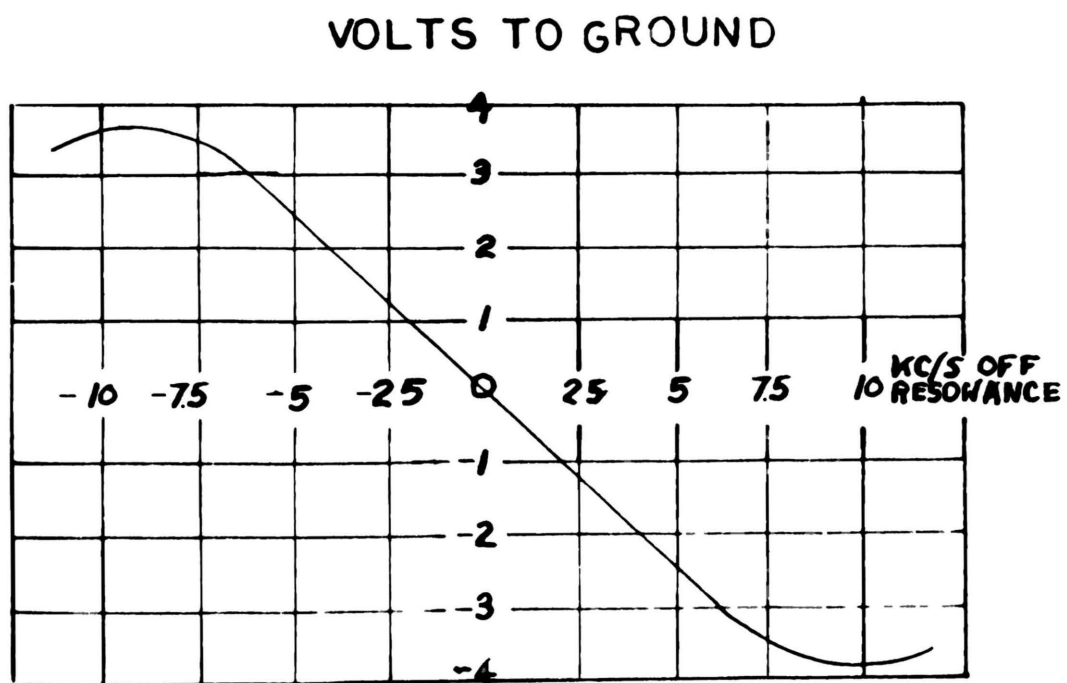

Fig 6 -Graph of Typical Discriminator  
Frequency-Voltage Function

## FINAL DESIGN AND CONSTRUCTION OF EQUIPMENT

## 1. Design of Frequency to Voltage Converter

This topic is considered before that of the controlled oscillator, since the design influences that of the oscillator.

## A. Discriminator center-frequency

The choice of discriminator frequency is limited to those for which discrimination transformers are available; these frequencies are 455 kc, 5000 kc, and 10.7 mc. Since satisfactory operation can be obtained at the lowest frequency, 455 kc, this is the choice, since it is well known that radio construction technique increases in difficulty with increase in frequency.

## B. Heterodyne oscillator frequency

Since the displacement-controlled oscillator frequency is not too critical, as will be shown, the heterodyne oscillator frequency was chosen as 1800 kc, permitting operation on either of two frequencies, 1345 kc or 2245 kc. The inexpensive quartz crystal used for frequency control has a frequency-temperature coefficient of less than 2 cycles /mc/°C - an amount negligible in this application.

## C. Circuit details

1. The circuit diagram is presented as Figure 4. From the input through the discriminator stage the circuit is typical of a frequency modulation receiver, with the exception of the crystal-controlled heterodyne oscillator. The coils  $L_1$  and  $L_2$  are wound on standard plug-in coil forms of the type usually associated with home-constructed receivers; use of plug-in coils facilitates changing frequency of operation

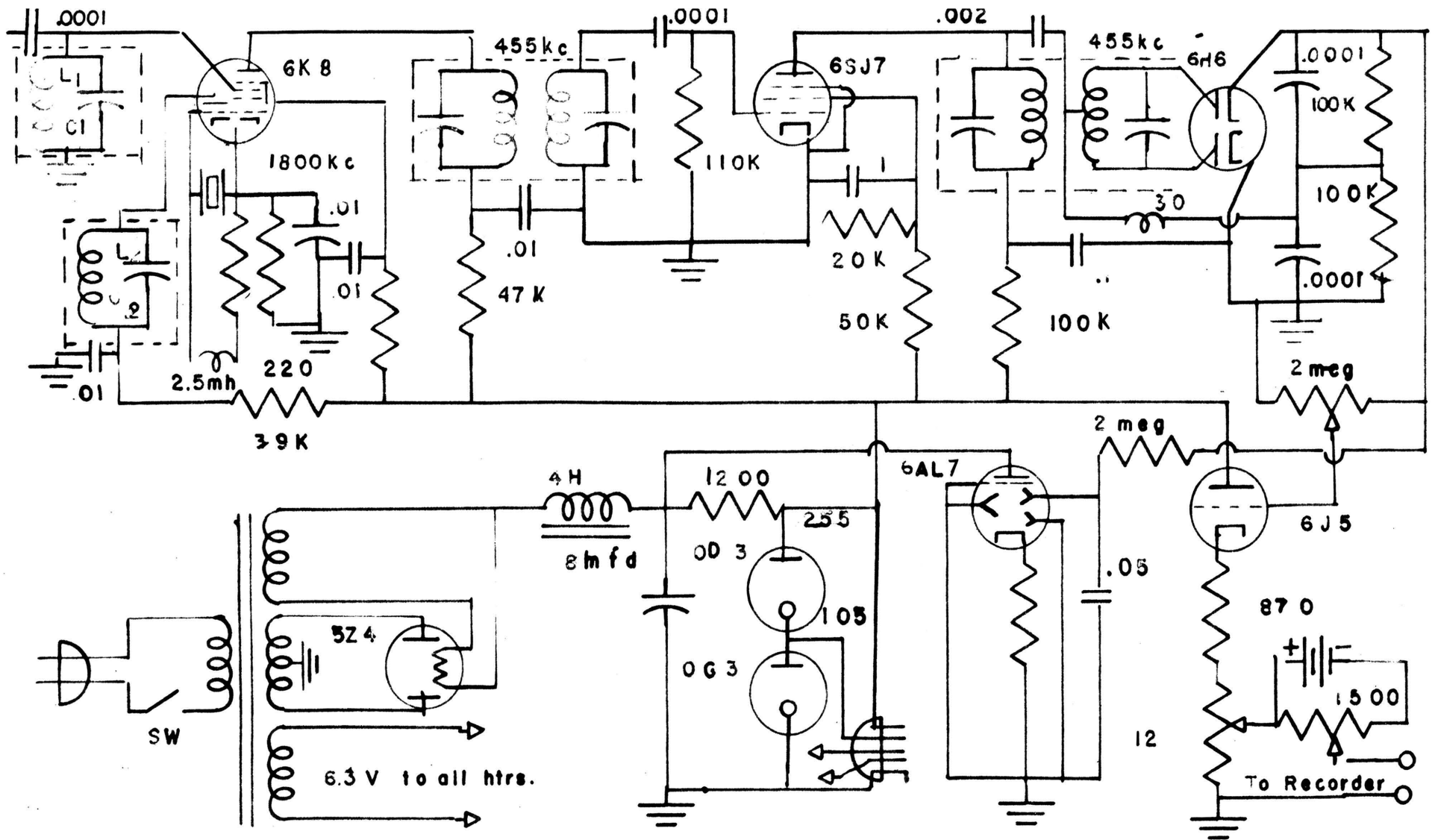

Fig 4.-Frequency-Voltage Converter

of the displacement-controlled oscillator. Switched multiple coils could be incorporated, of course, but at some what higher cost. Frequency change is not expected to be required often enough to warrant the complication.

2. Tuning indicator tube type 6AL7 CT, is included to facilitate tuning the displacement-controlled oscillator at the start of an expansion-shrinkage determination. This tube, similar to the more familiar "tuning eye", exhibits the "on channel" pattern when the discriminator output is zero; that is, when the received frequency (as heterodyned) is at the discriminator center-frequency. This is a relatively inexpensive convenience when the X-Y Recorder is invisible from the furnace locations.

3. Output coupling

Reference should again be made to Figure 4, the circuit diagram. At point A, the output of the discriminator is taken to the grid of tube type 6J5, which acts as a cathode-follower amplifier<sup>(2)</sup>. The principal purpose of this tube is to provide a low impedance output to match the input of the recorder. The battery and parallel adjustable resistance are used to cancel all but 5 millivolts of the voltage developed across R by the zero-input cathode current, thus providing the 5 millivolts indication on the X-Y

---

<sup>(2)</sup> For Cathode-Follower theory see, for example: Seely, S., *Electron Tube Circuits*, McGraw Hill, 1950.



Recorder desired at the zero displacement point. The calculations for the cathode follower and zero-set circuits are carried out in the appendix.

#### D. Power supply

The high and low voltage power supply design is entirely conventional. Two regulated plate voltages are provided. Power connections are brought to a socket for connection to the displacement-controlled oscillator.

## II. Design of Displacement-Controlled Oscillator

A. Obtaining linear displacement-frequency-change function; the usual expression for the resonant frequency of an inductance-capacitance is:

$$f = \frac{1}{2\pi L C} \quad \text{where:}$$

$f$  is frequency in cycles / second

$L$  is inductance in henries

$C$  is capacitance in farads

In a circuit tuned by a variable capacitance with a fixed inductance, it is evident that the frequency varies inversely as the square root of the capacitance. This is unfortunate in this application, since it is desirable to use a rotary variable capacitor of the straight-line frequency type; that is, one with semi-circular plates giving a change in capacitance proportional to angle of rotation of the control shaft. If however, instead of using only the variable capacitor as the capacitance in the circuit, we parallel the variable capacitor with a comparatively large fixed capacitor, it found that the change in frequency is very nearly proportional to the rotation of the variable capacitor.

Demonstration of the nearly linear results obtained in this man-

ner are illustrated by the graph, Figure 5. The calculations for this graph are carried out in the appendix in connection with the design of this equipment.

#### B. Choice of variable capacitor

As stated previously, a straight-line-frequency type of rotary variable capacitor is to be used. This sort of capacitor not only simplifies design calculations, but is desirable in that the zero-set point is not critical. This permits convenient use of the instrument for test samples differing somewhat from the nominal six-unit length.

The type of variable capacitor selected was the National Comp TMS-300, a double-bearing, ceramic insulated capacitor ordinarily used in low-power radio transmitters. In addition to other required properties, this particular model can be easily modified to have three different rates of capacitance change with rotation. This is accomplished by cutting the stator support bolts near the center, removing stator plates, and re-assembling with the stator plates end-supported in two sections. This provides a split-stator capacitor giving three capacitance ranges by alternate or parallel connection to the two stators. The low capacitance range, approximately 8-70 m.m.f.d. is ordinarily used, but the higher ranges would be desirable in applications requiring detection of very small displacements.

#### C. Mechanical Coupling from Furnace Distance Piece to Oscillator

The linear movement of the distance piece causes rotation of the frequency-control capacitor by means of an arm slotted to fit a pin attached to the distance pieces. This is illustrated in Figure 6.

It will be noted that the distance piece displacement does not cause an exactly proportional rotation of the capacitor arm. The error

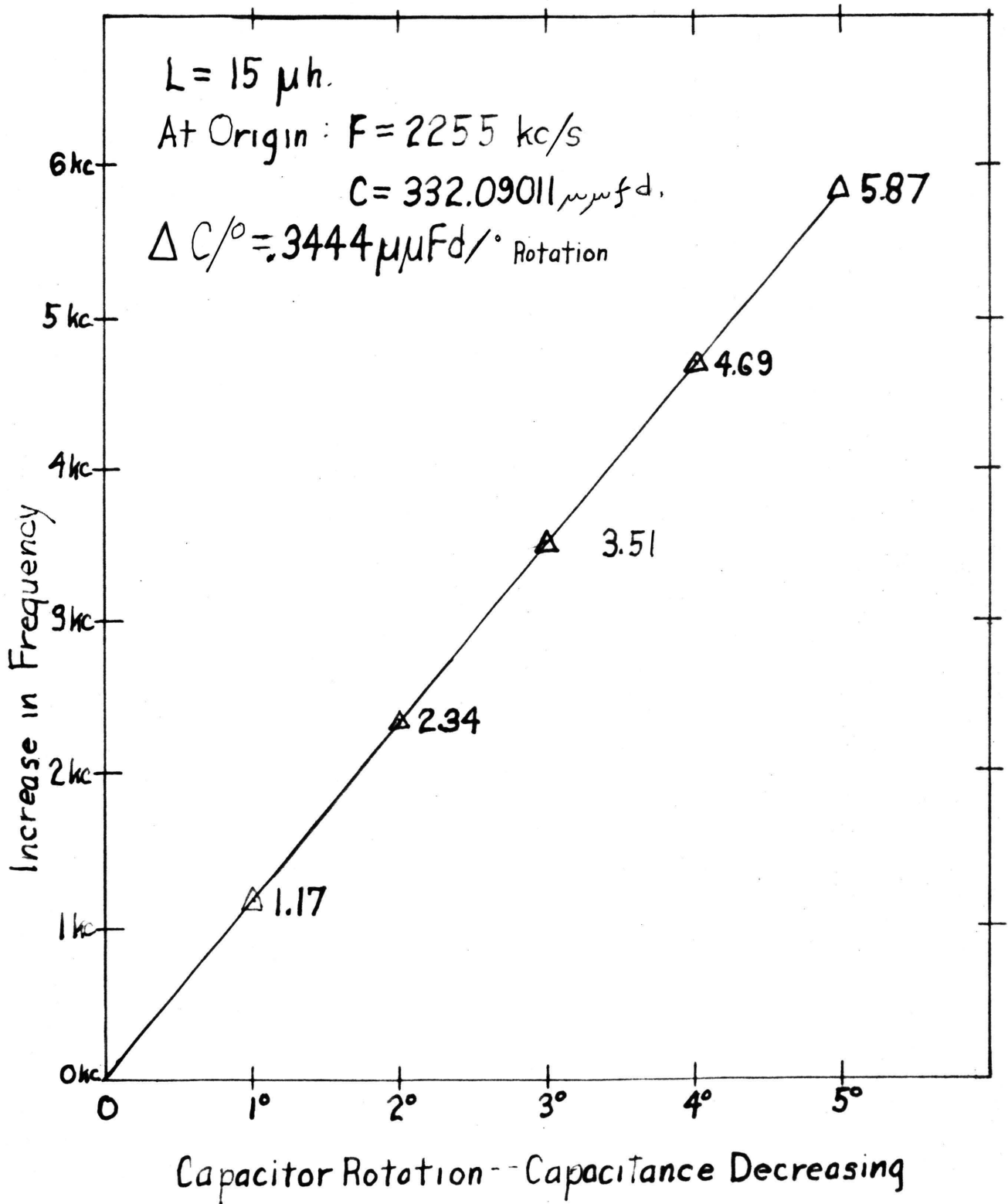

Fig. 5--Variation of Frequency as Function of Capacitor Rotation

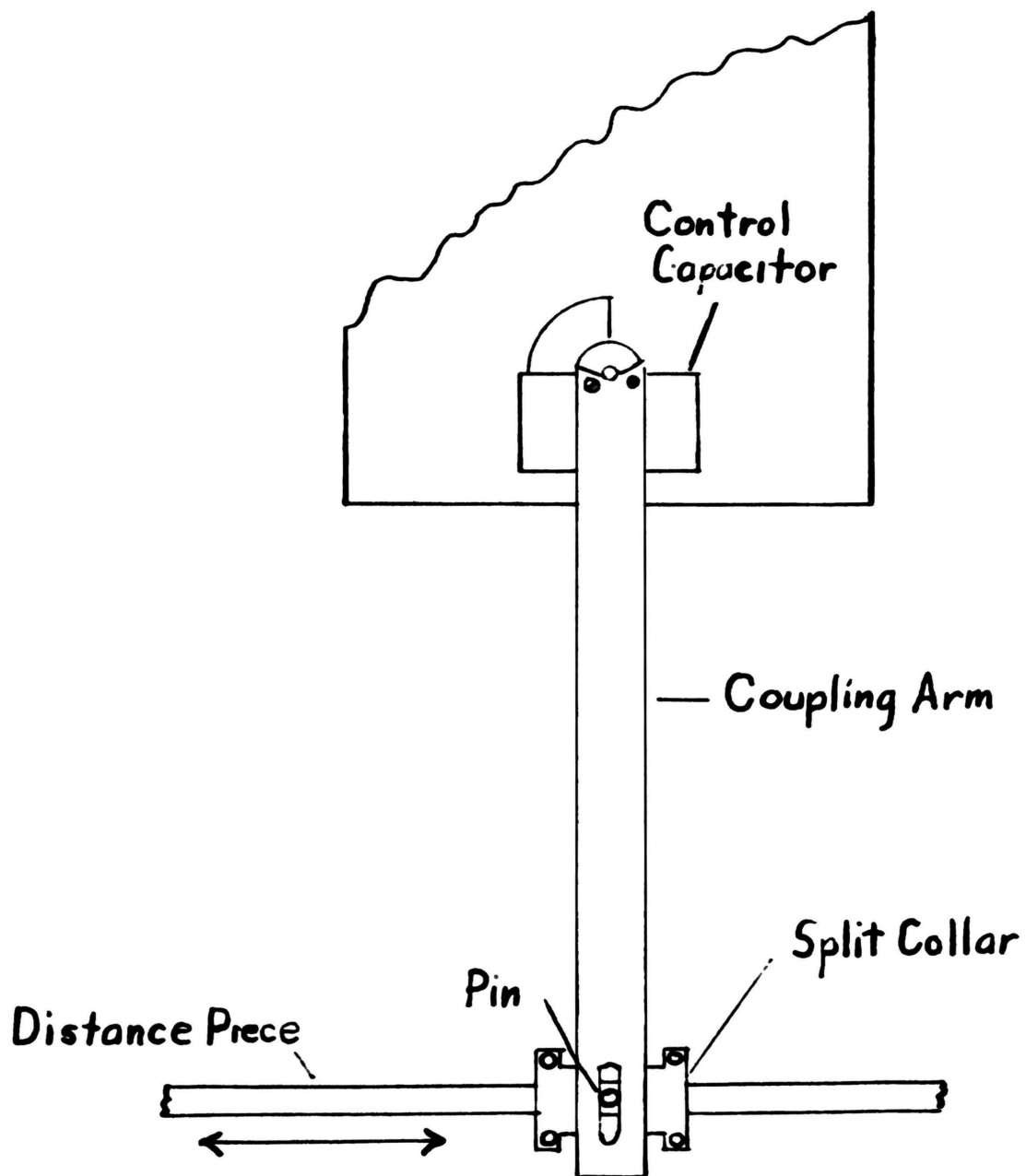

Fig.6- Method of Coupling Distance Piece to Oscillator

caused is slight, however.

If we let:

$r$  = length of capacitor arm, and

$d$  = amount of displacement, then

$$\theta \text{ indicated} = \tan^{-1} \frac{d}{r}$$

$$\theta \text{ true} = \frac{d}{r}$$

But for angles  $\frac{d}{r}$  less than 0.1 radian, for example, the difference between  $\frac{d}{r}$  and  $\tan^{-1}$  is less than  $.00034/.1$  or  $.0034$ , and the error in percent change in length of the test piece is  $.034\%$  on the ten percent range. The error does not exceed  $.1\%$  indicated length change until  $d/r$  exceeds  $.16$ . The error is practically insignificant for low values of  $d/r$ .

The length of coupling arm is dependent on the way the frequency of the controlled oscillator varies with rotation of the displacement-controlled capacitor, and must be calculated on the basis of the oscillator circuit parameters. This calculation proceeds as follows:

1. Determine the capacitance--rotation-angle function of the frequency-control capacitor.
2. On the basis of the total capacitance and inductance in the frequency control circuit, determine the amount of capacitance change required for the maximum frequency change for which the discriminator is linear each side of the zero point.
3. From 1 and 2 find the angle through which the variable capacitor is to be rotated for the maximum frequency change
4. From this value, determine the length of the arm on

the basis of the total displacement in the range to be measured.

The detailed calculations are contained in the Appendix. It is not necessary to have a separate coupling arm for each range covered, since on the lowest range sufficient change in frequency is obtained using the arm for the 5% range.

#### D. Achieving stability

Any oscillator used for precision measuring purposes must operate stably at the desired frequency. Stability is affected by the mechanical construction of the oscillator, by the electrical circuit, and by the effects of temperature.

1. Mechanical stability is achieved by solid mechanical construction, both as regards the chassis and component parts, and as concerns the wiring.
2. Electrical stability is achieved by use of a regulated power supply in order to minimize frequency drift caused by fluctuating voltages, and by use of an oscillator circuit inherently insensitive to changes in supply voltages. In this respect, this oscillator follows practice used in precision heterodyne oscillators.
3. Temperature stability is by far the most difficultly obtained property in an oscillator. Measures which can be taken are fully covered by Thomas<sup>(23)</sup>. Many of these are entirely inapplicable if ordinarily obtainable commercial components are to be used. The nearest approach with commercial components has been made in by using only

---

<sup>(23)</sup> Thomas, H. A., Theory and Design of Valve Oscillators, Chap. IV and V, Chapman and Hall, Ltd., London, 1951.

ceramic insulated capacitors, and use of a ceramic form for inductance. (Ceramic materials have a much lower coefficient of thermal expansion than have other insulation materials equally good from other standpoints). If it is found that, in this particular application, the heat radiated by the thermal expansion furnace is sufficient to cause frequency drift, two easily applied alternatives are available:

- a. Incorporation, as part of the oscillator capacitance having a negative temperature coefficient of capacitance (which opposes the normally-encountered negative frequency-temperature variation.)
- b. Insulation and temperature control of the entire oscillator.

The first alternative is preferable from a cost standpoint, and is usually adequate in an oscillator working in this relatively low frequency range. Neither has yet been applied to this equipment, since test with the furnace will be needed to show whether it is required.

#### E. Circuit

The circuit is shown as Figure 7, and is essentially the so-called "electron-coupled" type often used for a heterodyne frequency meter. Particularly useful features of this circuit are:

1. Its stability under fluctuating plate and screen voltages.
2. Minimum effect of the output circuit of the frequency of oscillation. Since the plate and screen voltages are reg-

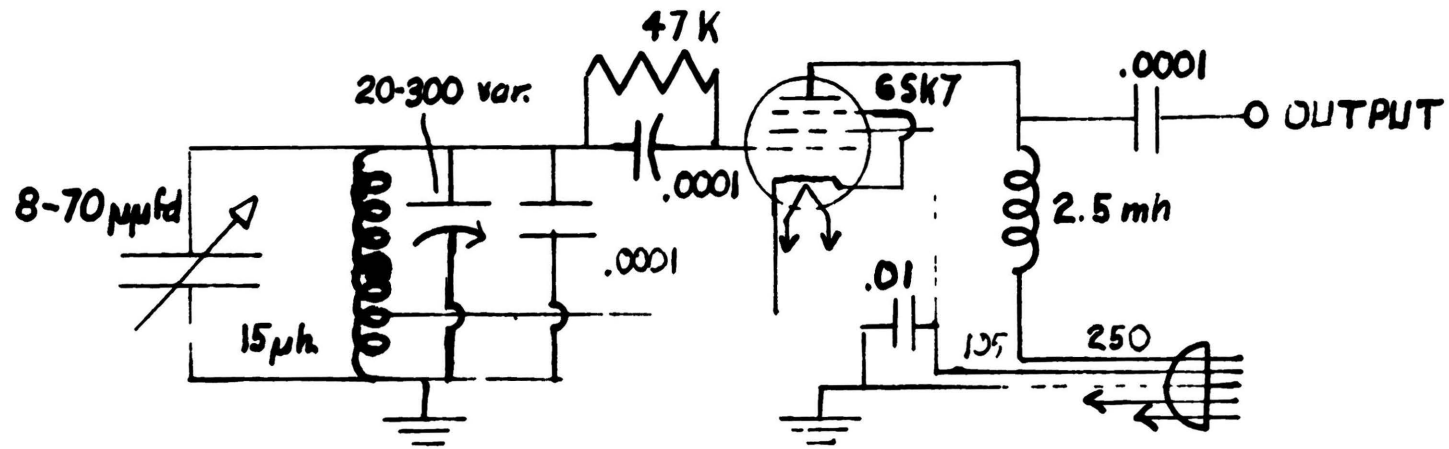

Fig. 7-- Circuit Diagram of Displacement -  
Controlled Oscillator



ulated, the latter is more important since it minimizes the effect of the input circuit of the frequency-discriminator equipment on the oscillation frequency.

#### F. Construction

The oscillator is built into a metal box 5 1/2" square. The sides of the box are made from 1/8" aluminum sheet. The corners of the box are secured with 1" x 1" aluminum angle strip, which is extended to form the bottom support. The box is closed on the bottom by a brass plate, 1/8" thick, which has a brass bearing for the capacitor control shaft. Another similar plate is mounted on the legs of the box, and carries another bearing for the other end of the capacitor shaft.

All components are fastened to the sides of the metal box. The tube is located outside the enclosure to remove a source of uncontrolled heat. The control shaft connects to the capacitor shaft with a brass coupling, for which an access hole is provided.

Other details of construction are shown by the photographs, Figures 8, 9, and 10.

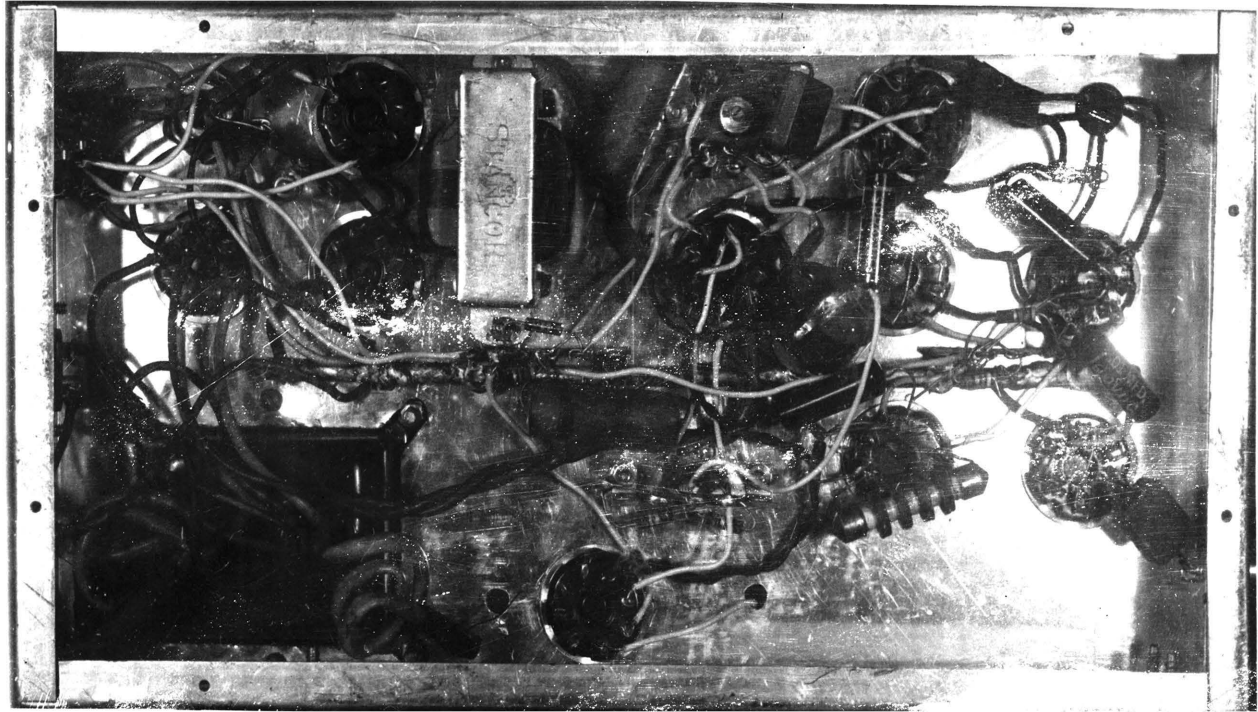

Fig. 8-- Bottom View of Frequency-to-Voltage Converter

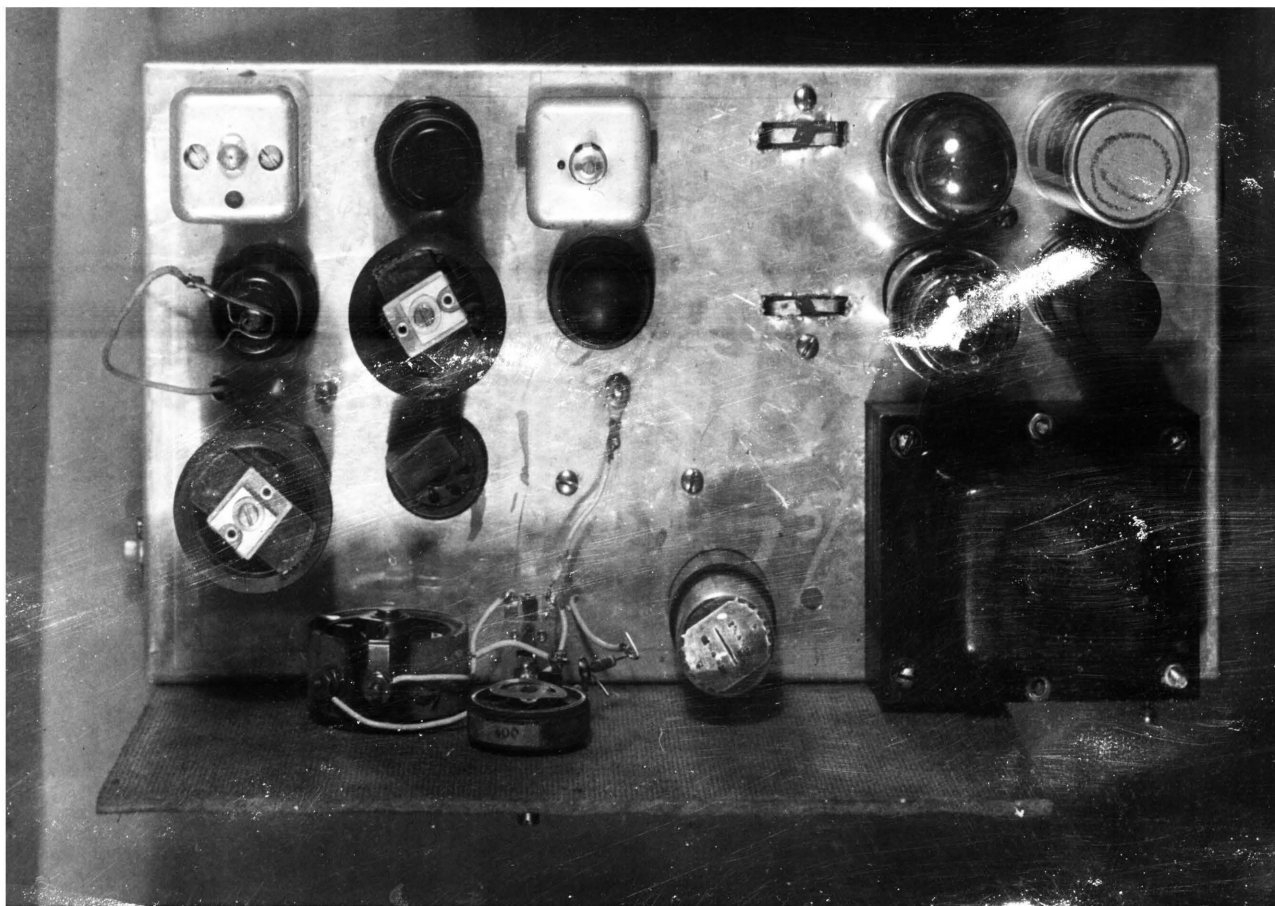

Fig. 9. Top View of Frequency-to-Voltage Converter

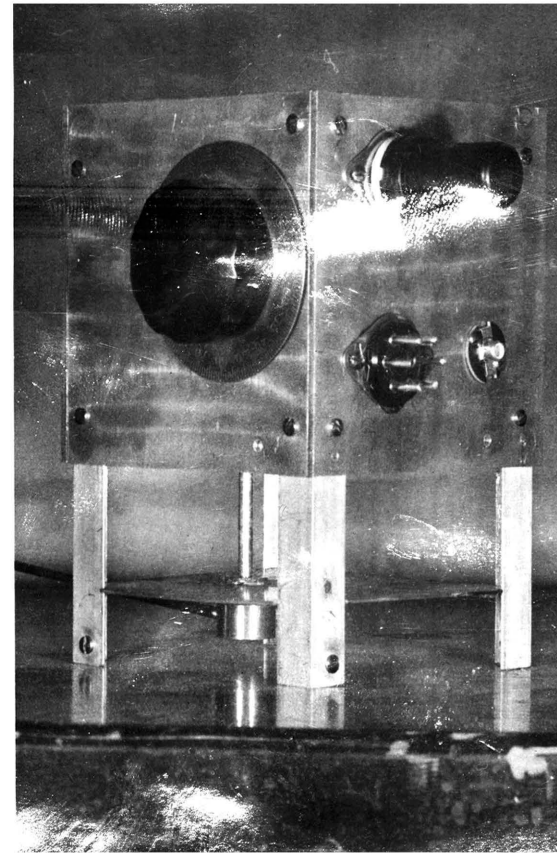
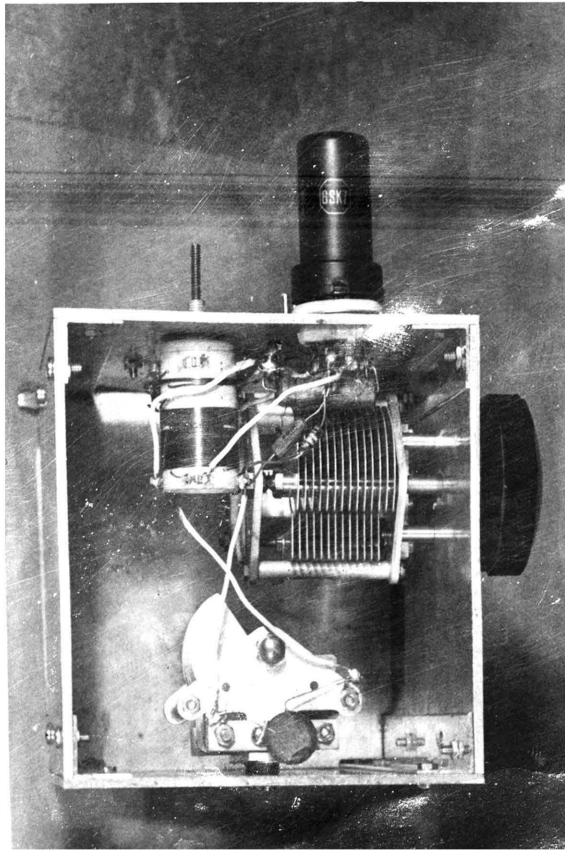

Fig. 10. Top and Front Views of Displacement-Controlled Oscillator

## EXPERIMENTAL RESULTS WITH EQUIPMENT

### I. Discriminator Output Measurements

During alignment of the discriminator circuit, it was found that the maximum voltage developed was approximately .5 volts, plus or minus, at approximately 10 kc/s. deviation each side of the center frequency of 455 kc/s. The response curve was not determined due to lack of a signal generator sufficiently precise for this determination. However, it is believed the discriminator possesses the frequency-voltage linear relationship desired, in view of the symmetrical location of the voltage maxima, and in consideration of the results obtained in the displacement tests.

### II. Displacement Tests

In lieu of operation with a recording potentiometer, the equipment was checked with an ordinary 0-64 mv. Leeds and Northrup student type potentiometer, connected from the top R to ground. This, of course, read the total d-c voltage at this point, which includes the voltage due to the static plate current with no voltage applied from the discriminator.

Displacement measurements were made with a 12'' rod connected to the control shaft of the displacement-controlled oscillator. Displacements were measured as the lateral traverse of the 12'' rod tip in a scale placed perpendicular to the zero portion of the rod. The results of two determinations are listed in Table II; one determination appears graphically as Figure 2.

TABLE II

Length of Control Arm: 12.0 inches

## Trial 1:

<u>Displacement Inches</u>	<u>Displacement Angle, Radians</u>	<u>Total Output, Millivolts</u>	<u>Change in Output From Zero Point</u>
0.0	0	10.20	0.00
0.2	.0166	7.92	2.28
0.4	.0333	7.65	2.55
0.2	.0166	12.45	2.25
0.4	.0333	12.80	2.60

## Trial 2:

0.0	0	10.95	0.00
0.2	.0166	8.54	2.41
0.4	.0333	8.26	2.69
0.2	.0166	13.34	2.39
0.4	.0333	13.69	2.64

---

## III Discussion of Results

Examination of the displacement-voltage graph shows that good linearity was obtained over a range of 0.4 inches (linearity is assuredly within the limits of accuracy of the potentiometer used for the tests).

It will be noted that linearity is obtained only for a displacement angle of .0333 radians, whereas the calculations indicated the angle should be much greater. This indicates that the assumptions made as to the capacitance variation with rotation were in error, or

that the inductance in the displacement-controlled oscillator is greater than that calculated; the latter conclusion leads to the result that the control capacitor is a greater proportion of the total circuit capacitance than that calculated, and therefore has a greater effect on the oscillation frequency. The simplest correction in either case is decrease of the inductance.

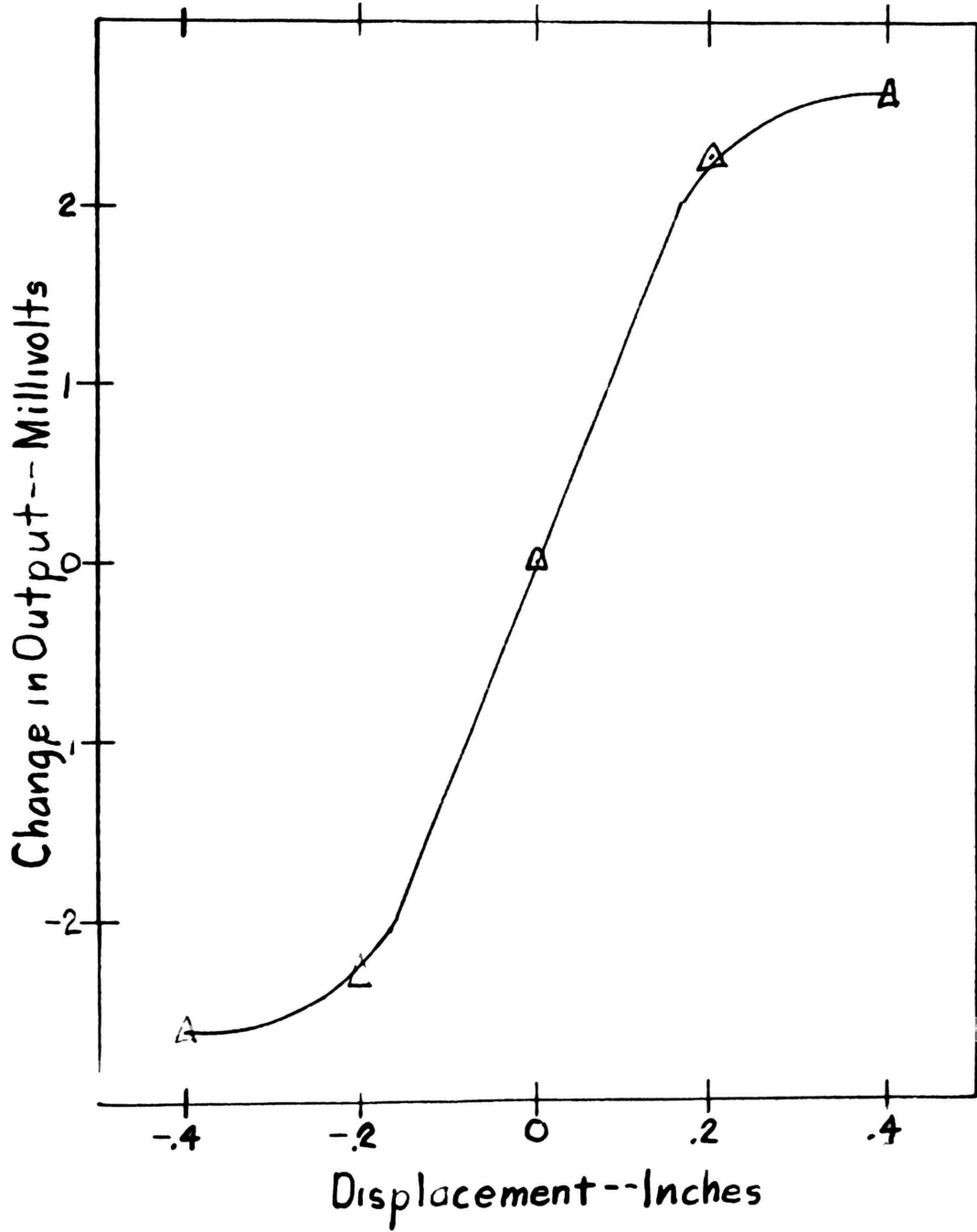

Fig. 11 - Displacement Test Results



### SUMMARY

This paper has reviewed the requirements of a device to measure the thermally induced length changes of ceramic bodies as to the ranges of length change encountered; review has also been made of the electromechanical devices usable for producing a voltage variation proportional to change in length, with the intent of application to the 0-10 millivolt range of a recording X-Y Recorder of the potentiometer type.

The design of a displacement-to-voltage converter using a variable capacitor has been discussed, and a useful instrument constructed on the basis of the design developed.

## APPENDIX A

Calculations showing linearity of oscillator frequency-change with control capacitor rotation.

Oscillator Initial Frequency — 2255.00 kc/s

Circuit inductance -- 15 microhenries

Control capacitance change per degree rotation = .34444 mmfd

At resonant frequency of 2255 kc/s :

$$C_0 = \frac{1}{f_0^2 (2\pi)^2 L} = \frac{1}{(2.255 \times 10^6)^2 (2\pi)^2 (15 \times 10^{-6})}$$

$$C_0 = 332.09011 \text{ mmfd}$$

$$C_{1^\circ} = 332.09011 - .34444 = 331.74567 \text{ mmfd}$$

$$\frac{f_{1^\circ}^2}{f_0^2} = \frac{C_0}{C_{1^\circ}} ; f_{1^\circ} = f_0 \sqrt{\frac{C_0}{C_{1^\circ}}}$$

$$f_{1^\circ} = 2255 \sqrt{\frac{332.09011}{331.74567}} = 2256.17$$

Similar calculations lead to these results:

<u>Angle of Rotation Degrees</u>	<u>Capacitance mmfd Change, Total</u>	<u>Capacitance, mmfd</u>	<u>Frequency</u>	<u>Frequency Change Total kc/s</u>
0	0	332.09011	2255.00	0
1	.34444	331.74567	2256.17	1.17
2	.68888	331.40123	2257.34	2.34
3	1.03332	331.05679	2258.51	3.51
4	1.37776	330.71235	2259.69	4.69
5	1.72220	330.36791	2260.87	5.87

## APPENDIX B

Calculation of length of coupling arm:

1. Determination of capacitance variation per degree rotation-

Maximum capacitance, 180° position (plates fully meshed)--70mmfd

Minimum capacitance, 0° position (plates all out) -- 8mmfd

Capacitance variation in 180° = 62 mmfd

Capacitance variation per degree =  $\frac{62}{180} = .34444$  mmfd/degree

2. Determination of capacitance change for desired frequency change-

Frequency at zero displacement  $\pm$  2255 kc/s

Frequency at full displacement = 2260 kc/s

Capacitance at 2255 kc/s = 332.09011 (see Appendix A)

Capacitance at 2260 kc/s = 330.62226 (Calculated as in Appendix A)

Change in capacitance = 1.46785 mmfd

3. Calculation of required angular rotation

$$\frac{\text{Change in capacitance}}{\text{Capacitance change/}^\circ} = \frac{1.46785}{.34444} = 4.26686^\circ$$

$$4.26686 \times \frac{\pi}{180} = .074465 \text{ radians}$$

4. Finding length of arm for .6 inch displacement-

Length of arm = r

Angle of rotation =  $\theta$  = .074465 radian

Displacement = d = .600 inches

$$\theta = \frac{d}{r}; \quad r = \frac{d}{\theta} = \frac{.600}{.074465} = 8.057 \text{ inches}$$

Use 8 inch arm

5. Finding length of arm for .3 inch displacement-

$$r = \frac{d}{\theta} = \frac{.300}{.074465} = 4.0287 \text{ inches}$$

Use 4 inch arm.

## APPENDIX C

## Cathode Follower Calculations:

Tube characteristics, Type 6J5

Plate Voltage . . . 250 volts

Grid Voltage . . . . -8 volts

Amplification Factor. . 20

Plate Resistance . . 7700 ohms

Plate Current . . . . 9 ma.

Calculation of Bias Resistor-

$$c = \frac{E_g}{I_p} = \frac{8}{.009} = 888 \text{ ohms}$$

Using  $R_c$  as cathode follower load resistance-

$$E_o = \frac{(\mu)R_L E_s}{r_p + ((\mu) + 1) R_L} = \frac{(20)(888)(1.5)}{7700 + (21)(888)}$$

Where:  $(\mu) = 20$

$R_L = 888$

$E_s = 1.5$  volts (assumed)

$r_p = 7700$  ohms

$E_o =$  output voltage across  $R_L$

Placement of tap on  $R_L$  to obtain 5 mv.

$$\frac{.005}{1.025} (888) = 4.34 \text{ ohms} = R_{Lo}$$

Determination of zero-point voltage to be cancelled-

$$E = I_p R_{Lo} = (.009)(4.34) = .039 \text{ volts} = 39 \text{ mv.}$$

## BIBLIOGRAPHY

- Batcher, R. R. and William Moulic, The Electronic Control Handbook, Caldwell-Clements Inc., New York, 1946
- Birch, R. E., see Stevens, D. K.
- Brown, F. B., Two Useful Electromagnetic Gauges, Jour. Sci. Instr., 25, 4, (1948)
- Coyle, M. B. and Haynes, F. G., A Remote Reading Dial Micrometer, Jour. Sci. Instr., 25, (8), pp. 27-6 (1948)
- Dayton, R. W., and G. M. Foley, Capacitance Micrometer, Electronics, 19, (9), pp. 106-11, (1946)
- Everhart, J. O., see Van der Beck, R. R.
- Foley, G. M., see Dayton, R. W.
- Giannini, G. N., Co., Commercial Literature
- Gordon, C. C. and J. C. Richmond, A Thickness Gauge for Enamel Coatings Jour. Amer. Cer. Soc., 33, (10), pp. 295-300, (1950)
- Haynes, F. G., see Coyle, M.
- Hursh, R. K., see Meid, W. J.
- Meid, W. J., and R. D. Hursh, Effects of Heating Rate on Shrinkage of Clays and Shales in Firing, Jour. Amer. Cer. Soc., 34, (9), p. 287, (1951)
- Moulic, William, see Batcher, R. R.
- Norton, F. H., Refractories, 3rd Edition, pp. 482-85, McGraw-Hill Book Company, New York, 1949
- Prytherch, W. E., A New Form of Dilatometer, Jour. Sci. Instr. 9, p. 128, (1932)
- Richmond, J. C., see Gordon, C. C.
- Robertson, V. A., see Scarlett, J. A.
- Rusher, M. A., Enamel Thickness Gage, Bull. American Cer. Soc., 14, (11) pp. 356-67 (1935)
- Scarlett, J. A., and J. A. Robertson, An Automatic Apparatus for Testing Refractories Under Tensile and Compressive Loads at High Temperatures Jour. Amer. Cer. Soc., 34, (11) pp. 348-53, (1951)

Sedalia, B. M., Bauxite versus Diaspore Clay in High Alumina (70%) Refractory Brick

Seely, S., Electron Tube Circuits, McGraw-Hill Book Company, New York, 1950

Shulze, C. E., personal communication.

Stevens, D. K, and R. E. Birch, Shrinkage Rates in Firing Fire-Clay Refractories, Jour. Amer. Cer. Soc. 30, (12) pp. 109-113, (1947)

Terman, F. E., Radio Engineering, 3rd Edition, McGraw-Hill Book Co., New York, 1948.

Thomas, H. A., Theory and Design of Valve Oscillators, Chap. IV and V, Chapman and Hall, Ltd., London, 1951

Turner, R. P., A Direct Reading Electronic Audio Frequency Meter, Radio and Television News, 45, (2), 54, (1951)

Van der Beck, R. R., and J. O. Everhart, Firing and Cooling Shrinkage Behavior of Structural Clay Bodies, Jour. Amer. Cer. Soc., 34 (12), p. 361, (1951)

## VITA

William Dean McKee, Jr., was born May 23, 1920 at Sigourney, Iowa to William Dean and Jessie C. McKee. He entered the public schools of that town, and continued there until 1930, when the family removed to Shenandoah, Iowa. There he completed elementary school, and in 1937 was graduated from the Shenandoah High School.

In the fall of 1937, McKee entered Tarkio, College, Tarkio, Missouri, transferred to Iowa State College, Ames, Iowa in 1938, and returned to Tarkio College in 1940. June of 1941, he received the degree of Bachelor of Arts from Tarkio College.

After three months as science instructor in the public high school of Cozad, Nebraska, McKee enlisted in the U. S. Army Air Forces on November 29, 1941. He was released from active duty as a Major on June 8, 1946. More than four years of this duty was at Patterson and Wright Fields with Headquarters, Air Technical Service Command. In general, military duty consisted of technical administration of the installation and maintenance of several types of airborne and ground radio equipment used by the Army Air Forces.

While still on terminal leave from the Army, McKee entered employment as a Registration Officer with the U. S. Veterans Administration at Dayton, Ohio, and continued that employment there, and at Cincinnati, Ohio and Lincoln, Nebraska until the summer of 1949.

In September of 1949, McKee enrolled at the Missouri School of Mines and Metallurgy, Rolla, Missouri and received the degree of Bachelor of Science in Ceramic Engineering in May, 1951. He then re-enrolled as a graduate student in ceramic engineering.



McKee was married in March, 1942, to Isabel Wood Miller of Ingomar, Pennsylvania. The couple have two children, Carol Lynn and Christopher Wood.