

26 May 2010, 4:45 pm - 6:45 pm

## Dynamic Soil Structure Interaction Analysis of Pile Supported High Rise Structures

Pulikanti Sushma  
IIIT Hyderabad, India

Ramancharla Pradeep Kumar  
IIIT Hyderabad, India

Follow this and additional works at: <https://scholarsmine.mst.edu/icrageesd>



Part of the [Geotechnical Engineering Commons](#)

### Recommended Citation

Sushma, Pulikanti and Kumar, Ramancharla Pradeep, "Dynamic Soil Structure Interaction Analysis of Pile Supported High Rise Structures" (2010). *International Conferences on Recent Advances in Geotechnical Earthquake Engineering and Soil Dynamics*. 12.

<https://scholarsmine.mst.edu/icrageesd/05icrageesd/session05/12>



This work is licensed under a [Creative Commons Attribution-Noncommercial-No Derivative Works 4.0 License](#).

This Article - Conference proceedings is brought to you for free and open access by Scholars' Mine. It has been accepted for inclusion in International Conferences on Recent Advances in Geotechnical Earthquake Engineering and Soil Dynamics by an authorized administrator of Scholars' Mine. This work is protected by U. S. Copyright Law. Unauthorized use including reproduction for redistribution requires the permission of the copyright holder. For more information, please contact [scholarsmine@mst.edu](mailto:scholarsmine@mst.edu).



Fifth International Conference on

## Recent Advances in Geotechnical Earthquake Engineering and Soil Dynamics and Symposium in Honor of Professor I.M. Idriss

May 24-29, 2010 • San Diego, California

### DYNAMIC SOIL STRUCTURE INTERACTION ANALYSIS OF PILE SUPPORTED HIGH RISE STRUCTURES

#### **Pulikanti Sushma**

Ph. D Scholar

Earthquake Engineering Research centre

IIIT Hyderabad, Gachbowli, Hyderabad 500032

India

Email: [sushmap@research.iiit.ac.in](mailto:sushmap@research.iiit.ac.in)

#### **Ramancharla Pradeep Kumar**

Associate Professor

Earthquake Engineering Research centre

IIIT Hyderabad, Gachbowli, Hyderabad 500032

India

Email: [ramancharla@iiit.ac.in](mailto:ramancharla@iiit.ac.in)

#### ABSTRACT

Experiences from past earthquake disasters clearly shows that the ground motion was responsible for majority of property and life loss. Among the collapsed structures during the 1964 Niigata earthquake, the 1995 Kobe earthquake, the 1999 Koceli earthquake, the 2001 Bhuj earthquake and the 2004 Sumatra earthquake, excessive damage was occurred to pile supported bridges, towers, chimneys, high rise structures, etc. In view of this there is a need to study the complex behavior of soil-pile-structure interaction problems using numerical methods.

In this research paper, a numerical study is carried out to understand the dynamic soil structure interaction of a high rise structure in a visco elastic half space in the presence of near by pile supported structures. The structure soil structure interaction is modelled by considering the direct methodology using a Finite element method based code ANSYS 10. Initially a two dimensional study is carried out for understanding the seismic response of group of high rise structures supported on pile foundations. The linear super structures are considered as framed structures of different dynamic characteristics supported on group of piles. Different case studies are made one in which the group effect of structures supported on piles are considered like group of two identical structures, group of three identical structures and group of three different structures, second one in which the effect of variability in structure height is considered like 5 storey structure, 10 storey structure and 15 storey structure and the third one in which the effect of variability in structure shape is considered. For each case the effect of structure soil structure interaction on seismic response is compared with fixed base response.

#### INTRODUCTION

In the analysis and design of engineered structures in the past, it was assumed that the foundation of structure was fixed to a rigid underlying medium (C. Zhang et al. (1998), M. Celebi (2001)). In the last few decades, however it has been recognized that Soil Structure Interaction (SSI) alters the response characteristics of a structural system because of massive and stiff nature of structure and, often, soil softness. Various studies have appeared in the literature to study the effect of SSI on dynamic response of structures such as nuclear power plants, high-rise structures and elevated highways (B. K. Maheshwari et al., (2004); A. Boominathan et al., (2004); V. Jaya et al., (2009); J L

Wegner et al., (2009)).

The problem of Structure soil structure interaction (SSSI) of near by structures has been started by the studies of Lee and Wisley in 1970's, in which they have investigated the seismic response of several adjacent nuclear reactors using a three dimensional scheme. After this Luco and Contesse (1973) followed by Wong and Trifunac (1975), studied the problem of interaction between infinite walls. Later Wang and Schmid (1992) used the finite element and boundary element coupling models to investigate the dynamic interaction through the under lying or surrounding soil

between three dimensional structures founded on square foundations. Recently Tsogka and Wirgin (2003) studied the seismic response of group of buildings anchored in soft soil layer overlying a hard half space . More recently L. A. Padron et al., (2009) studied the dynamic structure soil structure interaction of near by piled buildings under seismic excitation by using BEM-FEM model. From their study it has been concluded that SSSI effects on group of structures with similar dynamic characteristics are important.

In large number of works from the past the dynamic behavior of pile foundations have been analytically and numerically studied. Nogami and Konagai (1986) analyzed the dynamic response of pile foundations in the time domain using Winkler approach. Nogami and Konagai introduced the material and geometrical nonlinearity in the analysis using the discrete systems of mass, spring and dashpots. Later B. K. Maheshwari and El Naggar (2004) studied the three dimensional nonlinear analysis for seismic soil-pile structure interaction, in which they have used the advanced plasticity based soil model for material nonlinearity of near field soil. More recently Mohmmad M. Ahmadi et al.,(2008); B. K. Maheshwari et al., (2008) studied the behavior of group of piles to the seismic waves by considering different nonlinear soil models. It was observed that nonlinearity of soil significantly effects the seismic response of pile groups.

In this paper a numerical study is carried out by considering the complexities in soil-pile structure interaction of group of pile supported structures (Fig. 1). Initially a two dimensional study is considered for understanding the seismic response of high rise structure supported on piles. For this purpose different case studies are taken by considering strcuture soil structure interaction (SSSI). Case 1. Group effect of structures resting on piles like group of two identical structures, group of three identical structures and group of three different structures (Fig. 1) Case 2. Effect of variability in structure height like 5 storey structure (Fig. 2 a), 10 storey structure (Fig. 2 b) and 15 storey structure (Fig. 2 c) Case 3. Effect of variability in structure shape as shown in Fig. 3, like two buildings of same height but with different dynamic characteristics are considered. Dynamic analysis of each case is done by giving the base excitation as Elcentro earthquake record, because of the richness of knowledge on its characteristics which has made it a reference record for numerous research works. For each case study the response of SSSI is compared with the fixed base response (Fig. 4) and the effect of group of structures on seismic response of pile supported high rise structure is commented. The details of the same are given in rest of the paper.

### MODEL DESCRIPTION

The system under consideration comprises of several neighbouring framed structures of different heights, founded on pile groups embeded on a viscoelastic half space. A

plane sketch of problem is given in Fig. 1, with geometric properties of buildings and piles labelled. Pile groups are defined by length  $l_1$  and  $l_2$  and sectional diameter  $d$  of the piles and  $L_1$  and  $L_2$  be the width of pile cap. The structural heights are given by  $h_1$  and  $h_2$ . In studying the effect of change in response due to variability in structure height, a Structure b of same height as 15 storey structure with reduced stiffness on top floors is considered (Fig 3).

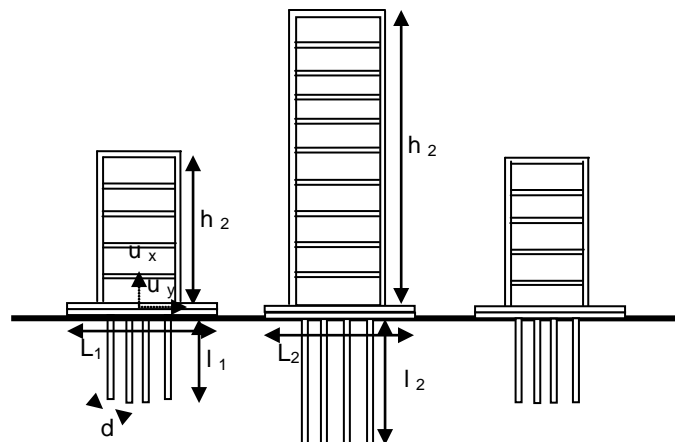

Fig. 1 Schematic diagram showing group effect of structures

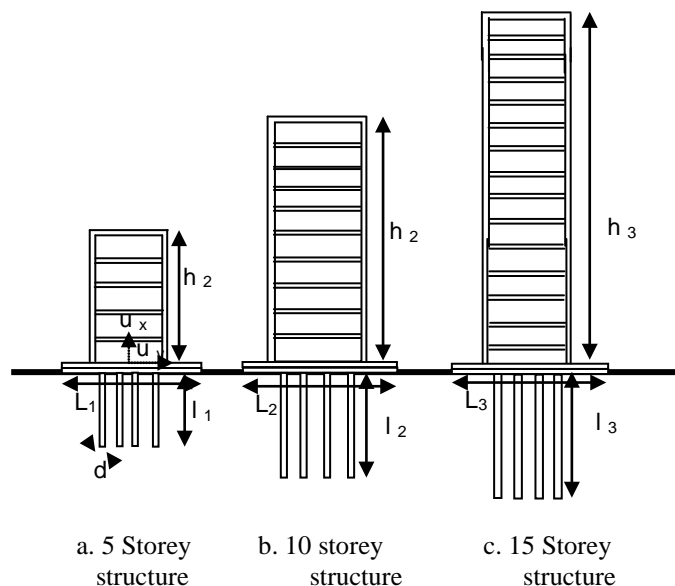

Fig.2 Schematic diagram showing variability in structure height

### NUMERICAL MODELING OF SOIL-PILE STRUCTURE SYSTEM

A two dimensional finite element model of soil-pile frame system of width 510m and length 260m as shown in Fig. 5 is considered and is modeled using ANSYS 10. The soil, pile and frame were modeled using 2 d eight noded quadratic elements with two degrees of freedom that is

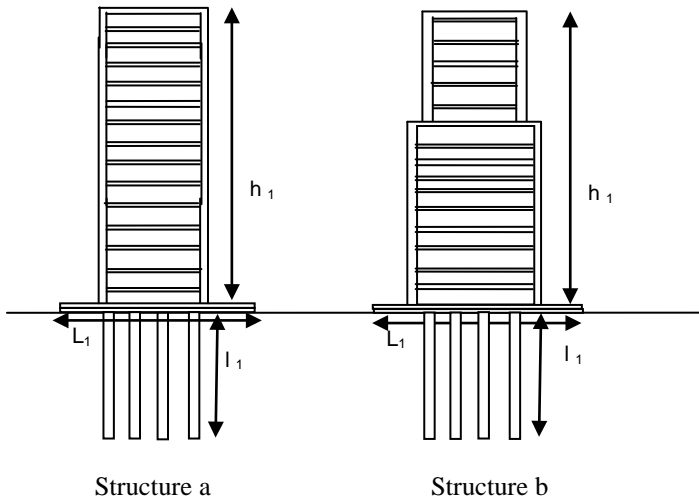

Fig. 3 Schematic diagram showing variability of structure shape

since it takes huge amount of computation time and resources. To overcome this some special absorbing boundary conditions like Viscous boundary are used where the reflections of wave that arise due to its interaction with boundary will be observed by viscous damper. (Sushma et al.,(2009)).

Generally SSI analysis procedures include direct approaches in which the soil and structure are modelled together and analyzed in a single step and substructure approaches where the analysis is broken down into several steps. In this study direct approach is used, where the pile, soil and frame system are modelled together in a single step accounting for both kinematic and inertial interaction. Inertial interaction develops in structure due to own vibrations gives rise to base shear and base moment, which in turn cause displacements of the foundation relative to free field. Kinematic interaction develops due to presence of stiff foundation elements on or in soil cause foundation motion to deviate from free-field motions. As illustrated in the Fig. 4, the earthquake ground acceleration  $\dot{U}_{as}$  is specified inside the soil, the resulting response of soil structure interaction system is computed from the following equation of motion

$$[M] \left\{ \ddot{\mathbf{u}} \right\} + [c] \left\{ \dot{\mathbf{u}} \right\} + [k] \left\{ \mathbf{u} \right\} = - [M] \left\{ \ddot{\mathbf{u}}_{gs} \right\} \quad (1)$$

Steven L Kramer ,(2003)

Where  $[M],[C],[K]$  are mass, damping and stiffness matrices

$\ddot{\mathbf{u}}_{as}$  Acceleration inside the soil

$\mathbf{u}, \dot{\mathbf{u}}, \ddot{\mathbf{u}}$  are displacement, velocity and acceleration of the system

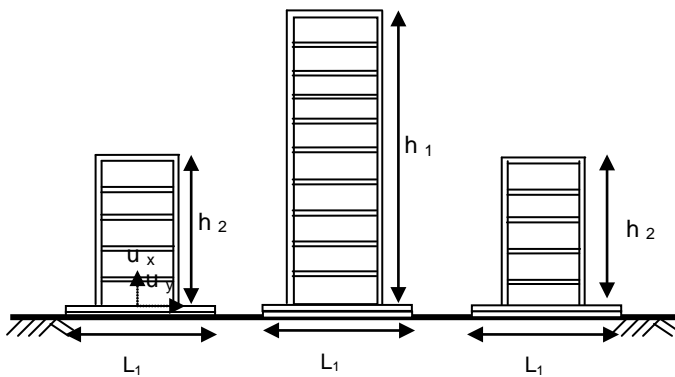

Fig. 4 Schematic diagram of Fixed base system

translation  $u_x$  in x and translation  $u_y$  in y direction. Huge size of the numerical model has been taken to reduce the boundary effect on the results. But taking the huge

In dynamic analysis the above Eq. (1) is constructed in incremental form using the Newmark average acceleration method which is unconditionally stable for any time step  $\Delta t$ . The dynamic behavior of group of structures with same heights and different heights are studied in order to enhance whether or not the SSSI effects between two or more adjacent buildings can be of importance. Also the dynamic behavior of structures of different height and different shape of same height are studied. Note that in all cases distance between neighbouring structures is assumed constant. For each case response of soil structure system is compared with fixed base system.

#### BOUNDARY CONDITIONS

The pile is completely embedded in the soil and it is assumed that soil and pile are perfectly bonded, so

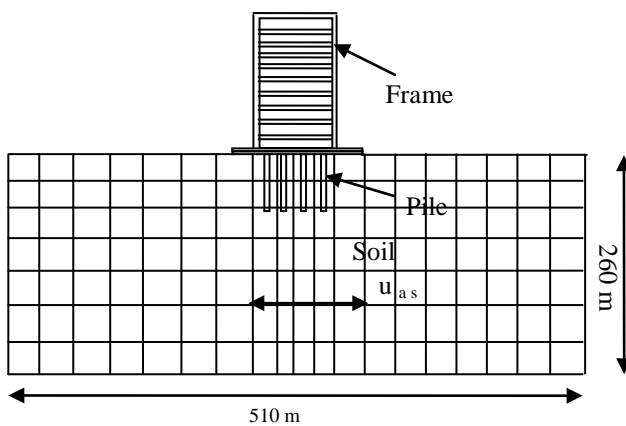

Fig. 5 Finite Element model of soil pile frame system numerical model is not always computationally preferable

separation between soil and pile is not considered. All three sides of soil are constrained in both x and y directions.

### MODEL PARAMETERS

The material properties of soil, pile, and frame are given in Table 1. It is assumed that pile is made up of concrete and has a square cross section with each side equal to 0.5 m. Four piles of length 15m and 10m each are considered for different building configurations with height of buildings 30m and 15m respectively. The length of the pile cap is

Table 1. Material Properties

Material	Youngs Modulus (kN/m <sup>2</sup> )	Density (t/m <sup>3</sup> )	Poisson's Ratio
Clayey Soil	40 x 10 <sup>3</sup>	1.8	0.4
Concrete Pile	19.36 x 10 <sup>6</sup>	2.4	0.2
Concrete Frame	25 x 10 <sup>6</sup>	2.4	0.2

taken as 10m and the distance between the adjacent buildings is also taken as constant for all cases studied. The frame considered is regular one which is widely used in constructions with one bay 10 stories and one bay 5 stories with beam size 0.4m, column size 0.4m and storey height equal to 3m and it is modeled as elastic material.

### DYNAMIC ANALYSIS

The influence of SSSI on dynamic response of piled structures is addressed in this section.

#### Single building

As a first case, soil structure interaction effects on single building is measured by giving NS component of Elcentro earthquake record as input to the pile soil system shown in Fig. 5. In order to able to relate the SSI effects, the top floor response of fixed base system and the top floor response of the frame with SSI are plotted as shown in Fig. 6. From the figure it has been observed that increase in response for SSI when compared to fixed base is because of accounting for the kinematic and inertial interactions in later case. That is in this ground acceleration is getting altered before reaching the surface because of presence of soil that is site effect and also the presence of stiff foundation elements that is kinematic interaction. Also in the response of structure with SSI, we see that there is some time for the wave to reach the structure which is the travel time of the S wave.

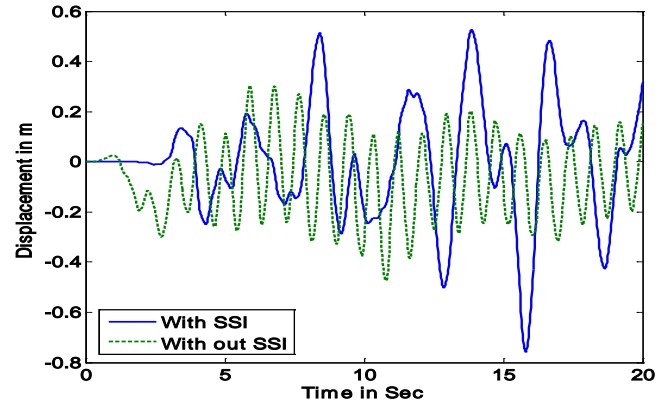

Fig. 6 Response of fixed base system and SSI

#### Case 1. Group effect of structures resting on piles

a. Group of two identical buildings. In this group of two identical buildings of same dynamic characteristics (mass, stiffness and frequency) are modelled as both fixed base system without considering SSI and also as a whole pile, soil and frame with SSSI. Two buildings of same structural aspect ratios (3) are kept adjacent to each other and analyzed. Fig. 7 shows the dynamic response of structure soil structure system together with response of fixed base system under seismic excitation. In case of

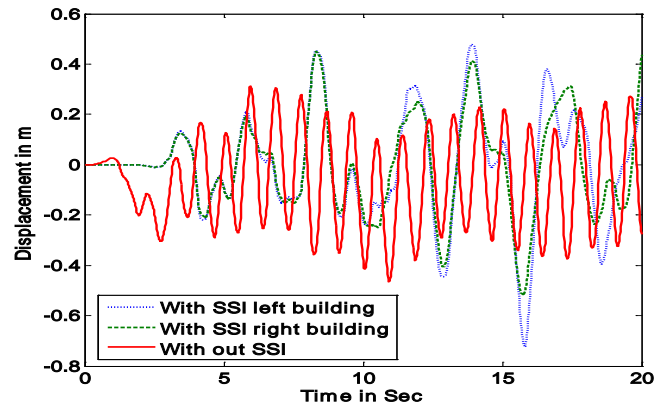

Fig. 7 Response of two identical buildings

structure soil structure interaction system the presence of neighbouring structure make a considerable change in response with a shift of natural period of the system as shown in Fig. 8. Because of the presence of neighbouring structure SSSI period and the fixed base period differ by a factor of 3. This shift of period is observed as soil and foundation elements are playing a major role in the response. At the time of shaking there is a change in dynamic characteristics of the soil. The stiffness and damping characteristics of soil may change significantly because of the interaction effect. Also it has been observed that soil between the two piles are more stressed (figure

not shown) which is also reason for the increase in the lateral response of structure. Where as in case of fixed base system the presence of neighbouring structure doesn't make any difference in the response and both the frames have same responses at different floor levels and also it has been observed that the response of the structure in the analysis of group of two identical buildings is same as response of structure in single building.

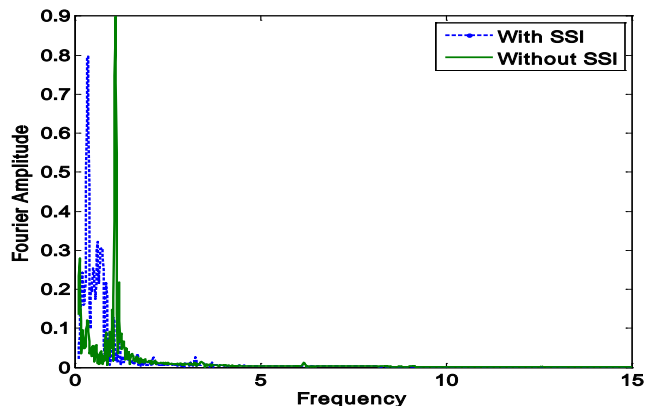

Fig. 8 Fourier amplitude spectrum

**b. Group of three identical buildings.** In this group of three identical buildings with same dynamic characteristics (mass, stiffness and frequency) are modelled as both fixed base system without considering SSI and also as a whole pile, soil and frame with SSSI. Three buildings of same structural aspect ratios as 3 are kept adjacent to each other and analyzed. Fig. 9 shows the dynamic response of group of three identical buildings. It has been observed that middle building is attracting more displacements because of trapping of seismic waves at the center due to multiple reflection of waves where as left and right buildings has same response. Same conclusions has been given by L. A. Padron (2009) in their work that central construction is usually subjected to strong shaking. The shift of natural period of system is also observed as shown in Fig. 10.

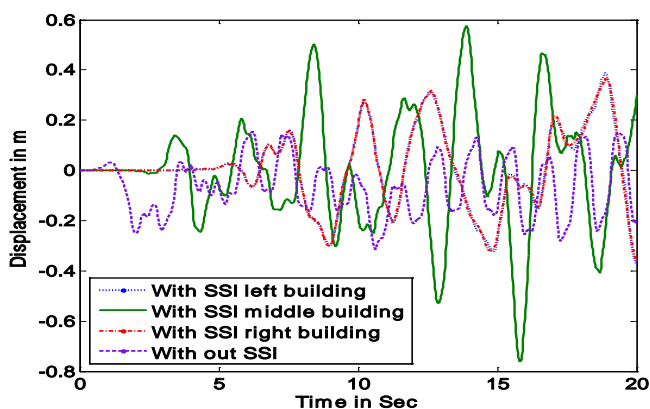

Fig. 9 Response of three identical buildings

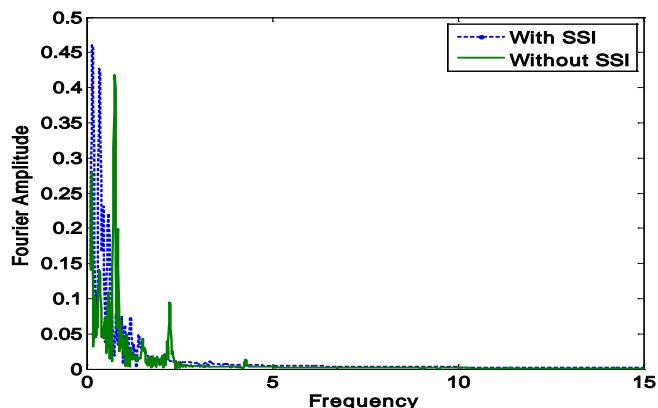

Fig. 10 Fourier amplitude spectrum

Because of the presence of neighbouring structure SSSI period and the fixed base period differ by a factor of 4.8. So a reasonable seismic analysis for high rise buildings supported on pile foundations is needed to produce a safe and economic design which takes into account this change in period due to group effect.

**c. Group of three different buildings.** In this a group of three different buildings with different dynamic characteristics (mass, stiffness and frequency) are modelled as both fixed base system without considering SSI and also as a whole pile, soil and frame with SSSI. Three buildings of different structural aspect ratios as 1.5, 3 and 1.5 are kept adjacent to each other and analyzed. Fig. 11 shows the dynamic response of group of three different buildings adjacent to each other under seismic excitation. From the figure it has been observed that

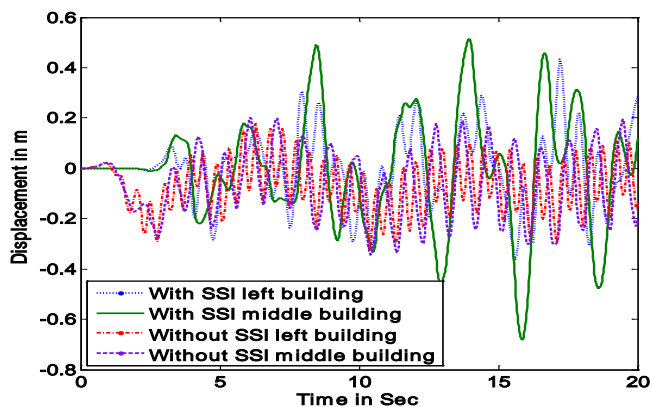

Fig. 11 Response of three different buildings

because of presence of short period buildings adjacent to long period buildings, the response is changed significantly as there is a change in dynamic characteristics of soil at the time of shaking. Also the response of both short buildings are almost same, so only one of the responses is shown in figure. Where as for fixed base case the response for both short and long periods buildings are almost same. To have a safe and economic design it is always preferable to do a detailed analysis by taking the group effect of buildings.

Fig. 12 shows the fourier amplitude spectrum, from which we can see that because of presence of neighbouring structures with different dynamic characteristics there is a major shift in SSSI period over fixed based period.

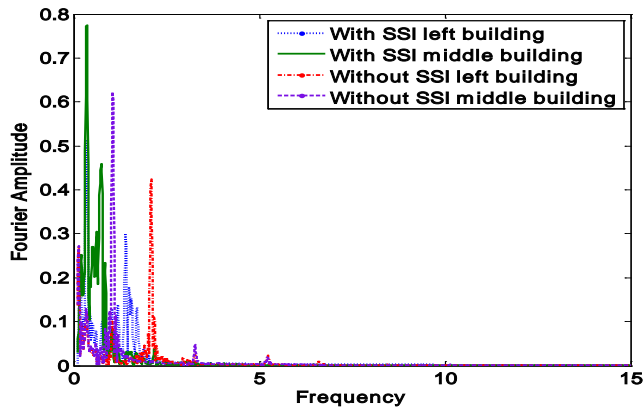

Fig. 12 Fourier amplitude spectrum

Case 2. Effect of variability in structure height

In this three different 5 storey, 10 storey and 15 storey framed structures are modelled individually as both fixed base system with out soil structure interaction and also as a pile soil structure system with SSI. Fig. 13 shows the fundamental mode shapes of all the three structures with their fixed base conditions having fundamental frequency as 2.39 Hz, 1.104 Hz and 0.68 Hz for 5 storey , 10 storey and 15 storey structures respectively.

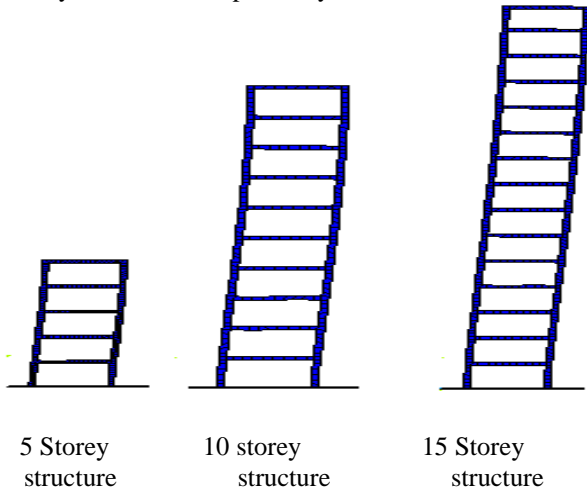

Fig. 13 Fundamental mode shapes

Fig. 14 shows the dynamic response of three structures under seismic excitation with SSI. From the figure it has been observed that after certain height of the building because of system damping effect there is a decrease in response of the system as we see in case of 15 storey building the response is less compared with 10 storey building. Fig. 15 shows the fourier amplitude spectrum

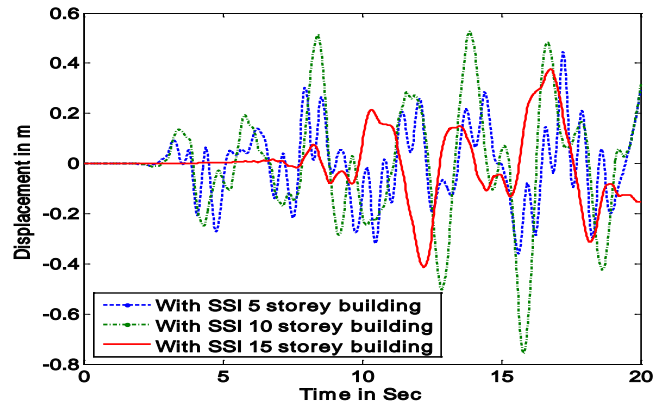

Fig. 14 Response of structures of variable height with SSI

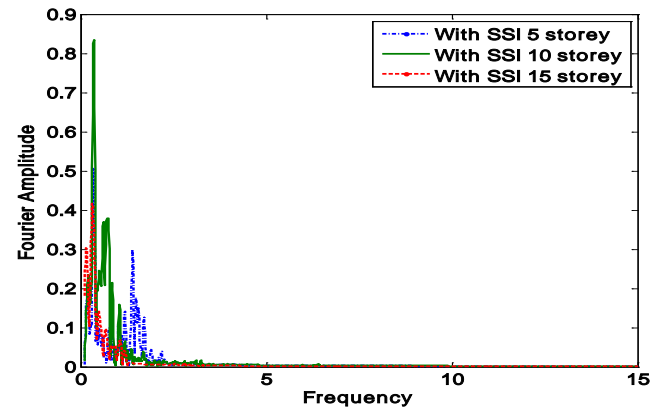

Fig. 15 Fourier amplitude spectrum

of three structures while considering SSI and all of them has almost same predominant period with different amplitudes. Fig. 16 shows the dynamic response of the system for fixed base system for all the three structures analysed individually. From the figure it has been observed that the

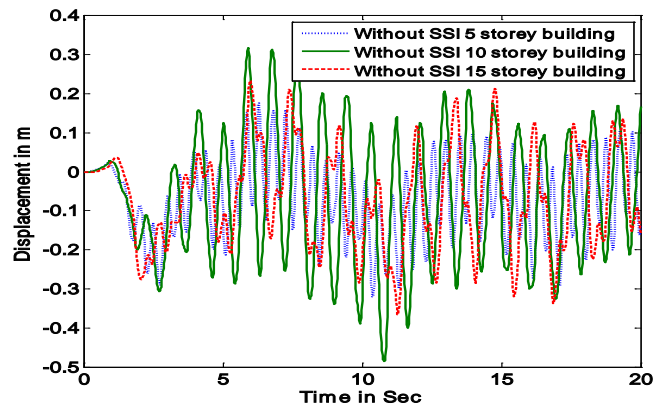

Fig. 16 Response of structures of variable height without SSI

for fixed base case responses are very less and by considering the whole pile soil system there is an amplification of waves. So while analyzing any structure consideration of whole system is important because site effect and the stiff foundation elements are playing a major role in response of system. Fig 17 shows the fourier amplitude spectrum from which we can see that fixed base predominant period are different from predominant with SSI, so while analysing any structure considering it as fixed base will lead to enormous results.

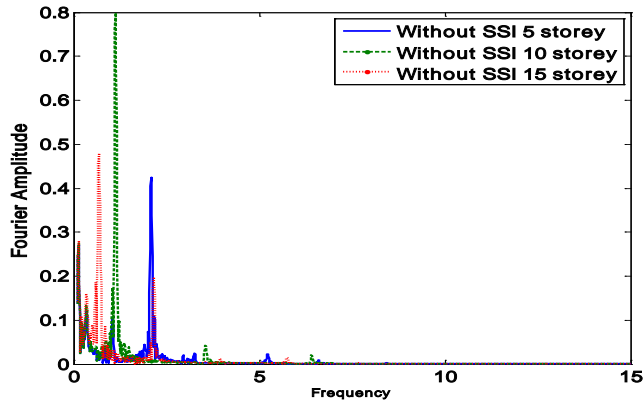
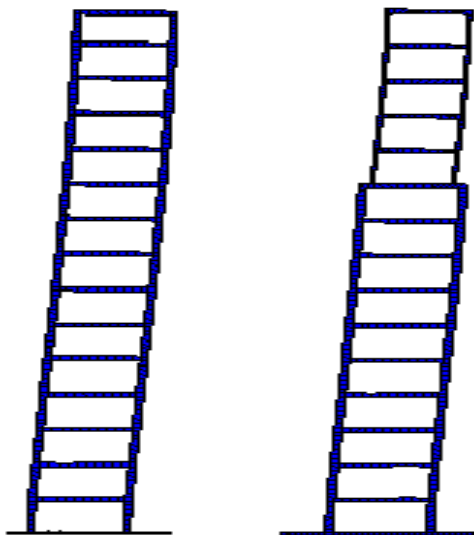

Fig. 17 Fourier amplitude spectrum

Case 3. Effect of variability in structure shape

In this two different structures of different dynamic characteristics with different shapes as shown in Fig. 3 are considered. The dyanamic analysis is carried out for both fixed base system with out soil structure interaction and also a pile soil system with SSI. Fig. 18 shows the fundamental



Structure a                      Structure b

Fig. 18 Fundamental mode shapes

mode shapes of Structure a and Structure b with their fixed base conditions having fundamental frequency as 0.68 Hz, 0.76 Hz respectively. Fig. 19 shows the dynamic response of both Structure a and Structure b with SSI. From the figure it hasbeen observed that for Structure b, the top response is little more compared to response of regular Structure a, because of sudden change in stiffness of the system, the system is becoming flexible and it is attracting more seismic forces. Fig. 20 shows the response of two structures for fixed base condition. From which it hasbeen observed that response of Structure a is more than the response of Structure b because of neglecting the actual field conditions.

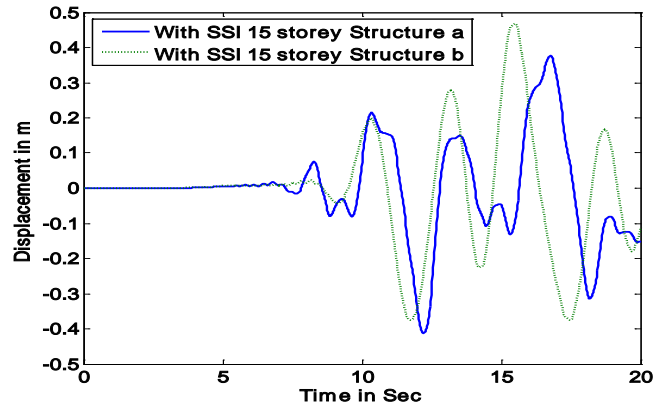

Fig. 19 Response of structures of variable shape with SSI

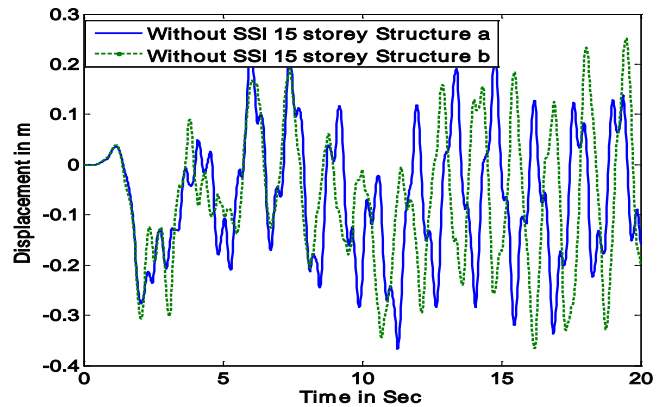

Fig. 20 Response of structures of variable shape without SSI

CONCLUSIONS

In this study the change in response of a high rise structure when a group of adjacent pile supported structures are present under seismic excitation is commented and for each case this SSSI response is compared with the conventional fixed base response.

In case of group of two identical structures with same dynamic characteristics, there is a significant change in the lateral response because of the presence of adjacent structures and there is a shift in period by a factor of 3.



When group of identical structures with same dynamic characteristics are present, SSSI effects have been found to be important. The middle structures are attracting more displacements because of trapping of seismic waves. Also in case of group of structures with different buildings the change in response is not so significant for fixed base structure without SSSI.

In case of response of structures with variable height, while considering SSI there is a decrease in response for 15 storey structure when compared to 10 storey structure which is not observed in fixed base system.

In case of response of structures of variable shape the top floors will attract more displacement because of reduced stiffness on top floors but in conventional fixed base case opposite behavior is observed.

The seismic behavior of high rise structures supported on pile foundation is different from that of rigid base structure. It has been observed from the responses of different cases that the group effect of neighbouring pile supported structures are playing a major role in dynamic analysis. So a reasonable seismic analysis for high rise buildings supported on pile foundations is needed to produce a safe and economic design.

#### REFERENCES

A. Boominathan [2004] "Seismic site characterization for nuclear structures and power plants", *current science*, vol. 87, no. 10, 25 Nov

M. Celebi and C. B. Crouse [2001] "Recommendations for soil structure interaction (SSI) instrumentation" Prepared for COSMOS (Consortium of Organizations for Strong-Motion Observation Systems) Workshop on Structural Instrumentation Emeryville, Ca. November 14-15

V. Jaya, G. R. Dodagoudar and A. Boominathan [2009] "Seismic Soil-structure interaction analyses of Ventilation stack structure". *Indian geotechnical journal*, 39(1), 2009, 116-134

Luco J E and Contesse L [1973] "Dynamic structure soil structure interaction". *Bull Seism Soc Am*; 63: 1289-303

C. Zhang and J. P. Wolf [1998] "Dynamic Soil – Structure Interaction", Elsevier, Sep

B. K. Maheshwari, K. Z. Truman, M. H. El Naggar, P. L. Gould [2004] "Three dimensional nonlinear analysis for seismic soil-pile-structure interaction". *Soil dynamics and earthquake engineering* 24, 343-356

B. K. Maheshwari and Pavan K. Emani [2008] "Effect of nonlinearity on dynamic behavior of pile groups". The 14<sup>th</sup> World conference on earthquake engineering, Oct 12-17, Beijing, China.

Mohammad M. Ahmadi and Mahdi Ehsani [2008] "Dynamic analysis of piles based on soil-pile interaction". The 14<sup>th</sup> World conference on earthquake engineering, Oct 12-17, Beijing, China.

Nogami T, Konagai K [1986] "Time domain axial response of dynamically loaded single piles". *Journal of Engg Mech ASCE*; 112(11):1241-52

L. A. Padron, J. J. Aznarez, O. Maeso [2009] "Dynamic structure-soil-structure interaction of near by piled buildings under seismic excitation by using BEM-FEM model". *Soil Dynamics and earthquake engineering*; 29:1084-1096

Steven L Kramer, [2003] "Geotechnical Earthquake Engineering". Pearson Education, Indian branch, New Delhi, India.

Sushma Pulikanti, Mohammad Ahmed Hussain, Ramacharala Pradeep Kumar [2009] "Amplification studies of local soils using Applied Element method". *International Journal of earth sciences and engineering*; Accepted July, 09

Tsogka C and Wirgin A [2003] "Simulation of seismic response in an idealized city". *Soil dynamics and Earthquake Engineering*; 23; 391-402

Wang S and Schmid G [1992] "Dynamic Structure-soil-structure interaction by FEM and BEM". *Computational Mechanics* 9:347-57

J. L. Wegner, M. M. Yao and S. K. Bhullar [May 2009] "Dynamic wave soils structure interaction analysis of a two way asymmetric building system DSSIA-3D". *Journal of Engineering and Technology Research*, Vol. 1 (2), pp. 026-038.

Wong HL and Trifunac MD [1975] "Two dimensional anti plane building soil building interaction for two or more buildings and for incident plane SH waves". *Bull Seism Soc Am*; 65(6); 1863-85

Yingcai Han and Shin-Tower Wang [2008] "Non-linear analysis of Soil-pile-structure interaction under seismic loads". The 14<sup>th</sup> World conference on earthquake engineering, Oct 12-17, Beijing, China.