

01 Feb 2000

Microwave Near-Field Reflection Property Analysis of Concrete for Material Content Determination

Karl Joseph Bois

Aaron D. Benally

R. Zoughi

Missouri University of Science and Technology, zoughi@mst.edu

Follow this and additional works at: https://scholarsmine.mst.edu/ele_comeng_facwork



Part of the [Electrical and Computer Engineering Commons](#)

Recommended Citation

K. J. Bois et al., "Microwave Near-Field Reflection Property Analysis of Concrete for Material Content Determination," *IEEE Transactions on Instrumentation and Measurement*, vol. 49, no. 1, pp. 49-55, Institute of Electrical and Electronics Engineers (IEEE), Feb 2000.

The definitive version is available at <https://doi.org/10.1109/19.836308>

This Article - Journal is brought to you for free and open access by Scholars' Mine. It has been accepted for inclusion in Electrical and Computer Engineering Faculty Research & Creative Works by an authorized administrator of Scholars' Mine. This work is protected by U. S. Copyright Law. Unauthorized use including reproduction for redistribution requires the permission of the copyright holder. For more information, please contact scholarsmine@mst.edu.

Microwave Near-Field Reflection Property Analysis of Concrete for Material Content Determination

Karl. J. Bois, *Member, IEEE*, Aaron D. Benally, and Reza Zoughi, *Senior Member, IEEE*

Abstract—One of the most important parameters associated with concrete is its compressive strength. Currently, there is no reliable nondestructive testing technique that is capable of robust determination of this parameter. Concrete is a heterogeneous mixture composed of water, cement powder, sand (fine aggregate), rocks of various size or grade (coarse aggregate), and air (porosity). Water and cement powder chemically combine into a cement paste binder which, in due curing time (28 days), produces concrete with its specified compressive strength. Compressive strength of concrete is strongly influenced by its water-to-cement (w/c) ratio as well as its coarse aggregate-to-cement (ca/c) ratio. Therefore, if these two parameters are determined using a nondestructive testing technique, then they may be correlated to the compressive strength. Near-field microwave nondestructive testing techniques, employing open-ended rectangular waveguide (OERW) probes, have shown tremendous potential for evaluating concrete constituent make-up. In this paper, the results of an extensive set of measurements, using these probes, are presented. The results demonstrate that the statistical distribution of the multiple measurements of the magnitude of reflection coefficient of concrete specimens with various constituent make-ups follows two well-known distributions as a function of frequency. It is shown that for the specimens investigated this distribution is Gaussian at 10 GHz and uniform at 3 GHz. Furthermore, the standard deviation of the measured magnitude of reflection coefficient at 10 GHz is shown to correlate well with concrete (ca/c) ratio, whereas, the mean of this parameter at 3 GHz is correlated well with concrete (w/c) ratio. Subsequently, these parameters may be used in conjunction with well established formulae or a look-up table to determine the compressive strength of a given concrete specimen.

Index Terms—Aggregate content, compressive strength, concrete, near-field microwaves, nondestructive testing.

I. INTRODUCTION

CONCRETE is the most common material used in many structures. Concrete is a heterogeneous material composed of cement powder, water, fine aggregate (sand), coarse aggregate (rocks), and air (porosity). The aggregates act as inert filler materials while the cement and water chemically react and form into cement paste binder. The individual proportion of each constituent in the mixture directly influences the physical, chemical and mechanical properties of concrete (e.g., cure-state and compressive strength). Therefore, a means for

predicting the constituent make-up of concrete is continuously sought (preferably nondestructive) by the construction industry. Currently, there are several approaches for evaluating various properties of concrete [1], [2]. When interested in determining the compressive strength of concrete, which is considered one of its most important parameters, the most common testing approach involves drilling out a cylindrical core from a concrete structure and subsequently testing it in the laboratory. This method is destructive, time consuming, costly, not extremely accurate and operator skill dependent [1], [2]. This technique alters the appearance and the physical properties of the tested structure. Moreover, it only provides information about the specific location from which the core is drilled out.

Alternatively, microwave near-field testing and evaluation techniques are shown to overcome most of these limitations [3]. Microwave signals can penetrate inside a dielectric medium, such as cement-based materials, and interact with its inner structure. One of the most important parameters influencing this interaction is the dielectric properties of the medium. The direct influence of the dielectric properties of a medium on microwave signals in turn influences the reflection properties of the medium measured by a probe. Dielectric properties of cement-based materials continuously change during the period in which the curing process takes place. Curing provides for cement-based structures to gain the final strength they are designed for (usually considered complete after 28 days) [4], [5]. During the curing process the water and cement molecules chemically combine into a binder, transforming the initial free water into bound water. The water-to-cement (w/c) ratio is one of the most influential factors in determining the cured strength of cement-based materials [4], [5]. Consequently, during the curing process the dielectric properties of a cement based material change. Thus, the curing process can be monitored by measuring the reflection properties of the material using an appropriate microwave measurement technique. Subsequently, one may correlate this temporal reflection property change to the cure-state and compressive strength of the material. When interested in inspecting concrete with microwave techniques, one must also be cognizant of the interaction of the signal with the aggregates, particularly the coarse aggregate. The degree to which microwave signals scatter/reflect off of aggregates is a function of the operating frequency, aggregate size, volume distribution and dielectric properties. Therefore, it is expected that the (statistical) characteristics of reflected microwave signals from concrete should provide information about the aggregate size and volume distribution as well. These two parameters are also shown to influence the compressive strength of concrete [4], [5]. Thus, a comprehensive evaluation

Manuscript received April 28, 1999; revised January 10, 2000. This work was supported by the joint National Science Foundation (NSF) (Contract CMS-9 523 264) and the Electric Power Research Institute (EPRI) (Contract WO 8031-09) Program on Sensor and Sensor Systems for Power Systems and Other Dispersed Civil Infrastructure Systems.

K. J. Bois is with Hewlett-Packard Company, Ft. Collins, CO 80528 USA.

A. D. Benally and R. Zoughi are with Applied Microwave Nondestructive Testing Laboratory (AMNTL), Electrical and Computer Engineering Department, Colorado State University, Fort Collins, CO, 80523 USA.

Publisher Item Identifier S 0018-9456(00)02858-8.

of the characteristics of a reflected signal from a concrete structure is expected to provide information about its compressive strength. Consequently, in the past few years several research efforts have focused on characterizing the near-field microwave reflection properties of cement-based materials for determining their constituent make-up, cure-state properties and compressive strength. A succinct overview of the outcome of these investigations is presented here.

A. Cement Paste (Water and Cement)

- Near-field microwave reflection property analysis of cement paste specimens with various (w/c) ratios was conducted during the 28-day prescribed curing period, using open-ended rectangular waveguide (OERW) probes at several frequencies [6]. The results showed a correlation between the magnitude of reflection coefficient, $|\Gamma|$, referenced to the waveguide aperture and the (w/c) ratio as well as the compressive strength of the cured specimens. A similar investigation was also conducted on cured cement paste specimens using monopole probes, and a similar correlation was obtained [7].
- Later it was shown that using the OERW probe, cure-state monitoring of cement paste specimens, with varying (w/c) ratios, can be conducted at all stages of the curing process [8].

B. Mortar (Water, Cement, Sand, and Air)

- A simple relationship between the standard deviation of the magnitude of reflection coefficient, $\sigma_{|\Gamma|}$, and sand-to-cement (s/c) ratio in mortar, was obtained using the OERW probe at 10 GHz. It was also shown that information about the (w/c) ratio of mortar can be obtained when using the average value of $|\Gamma|$ at lower microwave frequencies, in particular at 3 GHz [9].
- A three-phase dielectric mixing model was also derived to predict the constituent volume content of a mortar specimen. Consequently, porosity (volume content of distributed air) in a mortar was shown to be easily determined using this mixing model [10].

C. Concrete (Water, Cement, Sand, Coarse Aggregate, and Air)

- The polarization properties of OERW probes operating at 4 GHz were used to detect the location of a steel reinforcing bar in a concrete slab, and a break in the bar [11]. Later, it was demonstrated that manipulation of the operating frequency using the same probe can yield information about the aggregate size distribution in concrete [12].
- Through extensive measurements using concrete specimens with various (w/c) ratios and constituent make-up, it was recently demonstrated that concrete cure-state, which is an important issue in construction industry, can be unambiguously determined when making daily measurements of $|\Gamma|$ [8].
- Determination of fresh concrete (w/c) ratio, was also addressed and shown to be unambiguously determined independent of (s/c) ratio and coarse aggregate-to-cement (ca/c) ratio [8]. This is an important finding and has significant practical and process control ramifications since with this

information an operator is capable of determining the (w/c) ratio of a batch plant concrete at the time of pouring [3].

- The extent of aggregate segregation in concrete placement is also shown to be evaluated using the statistics of the measured $|\Gamma|$ at frequencies greater than 8 GHz. This information can be easily obtained for concrete members such as walls and columns in which aggregate segregation (an undesirable feature) is likely to occur [3].

D. Masonry (Hollow Mortar Brick)

- Using a simple near-field and nondestructive microwave inspection technique employing an OERW probe at 3 GHz (S-band), it is possible to distinguish between empty and grout-filled (grout is a very high (w/c) ratio form of mortar) masonry cells [13].

In each of these studies, the measured mean of $|\Gamma|$ referenced to the OERW probe aperture or its standard deviation, $\sigma_{|\Gamma|}$, was correlated to a particular parameter of interest such as cure-state or compressive strength. Concrete coarse aggregate-to-cement (ca/c) ratio determination is also possible using near-field microwave nondestructive evaluation techniques employing OERW probes. Even though coarse aggregate primarily acts as inert filler material in a concrete mixture (replacing the more expensive cement), its proportion in the mixture can significantly impact the compressive strength of the concrete [14].

Consequently, the results of an extensive investigation on determining concrete (ca/c) ratio, using the statistical properties of the measured near-field $|\Gamma|$ for several specimens with varying (w/c) ratios and constituent make-ups, as a function of frequency are presented in this paper. The specimens used in this study contained 3/8 in-grade aggregate in addition to fine aggregate (sand). Specimens with 0.5 in-grade aggregate were also examined and similar results to those presented here were obtained [3]. It will be shown that the point-to-point variation in the measured $|\Gamma|$, at relatively high microwave frequencies, can be used as a means for predicting the (ca/c) ratio in concrete. At these frequencies the scattering from the coarse aggregate influences the measured properties of $|\Gamma|$. However, at lower frequencies the variations in the measured $|\Gamma|$ are expected to be less sensitive to scattering from the coarse aggregate. To this end, the probability density function (pdf) and the cumulative distribution function (cdf) of the measured $|\Gamma|$ are studied at 3 GHz (S-band) and 10 GHz (X-band). The ultimate goal of this study is to be able to classify concrete material constituents in distinct groups using the statistical properties of their measured $|\Gamma|$ so that this information can be used to estimate the compressive strength [4], [5], [15]. This is to say that if such measured data are shown to possess a well-known distribution (e.g., Gaussian, uniform or Laplacian), existing statistically based decision schemes can be used to determine the constituent make-up of a concrete specimen from a collection of measurements of reflection coefficient at different microwave frequencies [3].

II. APPROACH

Several sets of $8\text{in} \times 8\text{in} \times 8\text{in}$ cubic concrete specimens were produced. The dimensions of the specimens were chosen such

TABLE I
CONSTITUENT MIXING PROPORTIONS OF CONCRETE SPECIMENS CONTAINING 3/8in-GRADE AGGREGATE

Concrete Specimen					
no. 1	no. 2	no. 3	no. 4	no. 5	no. 6
(w/c) 0.50	(w/c) 0.50	(w/c) 0.50	(w/c) 0.60	(w/c) 0.60	(w/c) 0.60
(s/c) 1.5	(s/c) 1.5	(s/c) 1.5	(s/c) 1.5	(s/c) 1.5	(s/c) 1.5
(ca/c) 1.0	(ca/c) 1.5	(ca/c) 2.0	(ca/c) 1.0	(ca/c) 1.5	(ca/c) 2.0

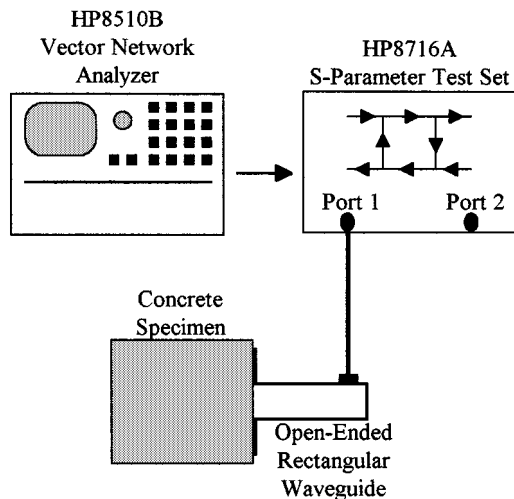

Fig. 1. Experimental setup.

that the OERW probe sees an infinite half-space of concrete at the operating frequencies of interest; namely, 3 GHz and 10 GHz. The material composition of each concrete specimen is shown in Table I. The specimens were left in the hydration room for three days and in room temperature thereafter during the remaining 28-day curing period. The measurements reported here were conducted after day 28. The (w/c) ratios of 0.5 and 0.6 were chosen since they allow for a maximum range of (ca/c) ratios without presenting workability problems ([4], p. 80). The measurements of the reflection coefficient of the OERW probe, referenced to the probe aperture, in contact with the concrete specimens were conducted using an HP8510B vector network analyzer, as shown in Fig. 1. To obtain the mean and standard deviation of the measured magnitude of reflection coefficient for these specimens, 20 and 160 independent measurements were conducted on four sides (excluding the top and bottom) of each specimen at 3 GHz and 10 GHz, respectively. To ensure that the measurements were uncorrelated (i.e., independent) the spacing between each measurement was at least equal to that of the waveguide aperture dimension [16]. This is the reason for the greater number of independent measurements performed at 10 GHz compared to that at 3 GHz. Consequently, for each specimen the average and standard deviation of these independent measurements were obtained.

III. RESULTS

A. X-Band Measurements Results

Fig. 2(a) shows the pdf of the 160 measurements conducted for specimen no. 6 at 10 GHz (X-band) in histogram form. The

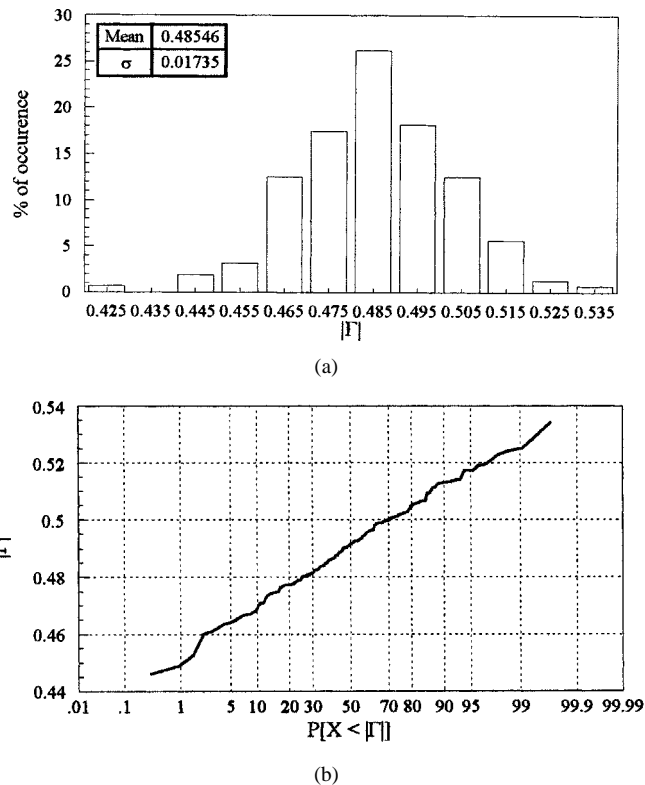

Fig. 2. (a) Histogram of the magnitude of reflection coefficient (160 measurements) at 10 GHz (X-band) for a concrete specimen possessing $w/c = 0.60$, $s/c = 1.5$ and $ca/c = 2.0$. (b) Cumulative distribution function of the magnitude of reflection coefficient (160 measurements) at 10 GHz (X-band) for a concrete specimen possessing $w/c = 0.50$, $s/c = 1.5$ and $ca/c = 2.0$.

results for this specimen are specifically shown here since the influence of scattering by the aggregate is most significant for this specimen (i.e., $ca/c = 2.0$). The results show a pdf that fits the characteristics of a Gaussian distribution. To verify this, the cdf of this specimen was calculated and is plotted in Fig. 2(b). The cdf of a Gaussian distribution has an exponential behavior which when plotted in a logarithmic scale, it results in a line with a slope proportional to its standard deviation. Fig. 2(b) clearly shows this characteristic trend. All specimens listed in Table I resulted in a similar pdf at 10 GHz [3]. For brevity the results of the measured mean and standard deviation of $|\Gamma|$ for the remaining specimens are listed in Table II. Therefore, the process describing the statistical distribution of the measured $|\Gamma|$ at 10 GHz (or higher) is thought to be a Gaussian distribution. This is also expected since at higher frequencies, where the wavelength of the exciting wave is comparable in size to the dimensions of the scatterers, the scattering (direct and multiple) by uniformly distributed scatterers (e.g., aggregate) results in the

TABLE II
MEAN AND STANDARD DEVIATION OF REFLECTION COEFFICIENT MEASUREMENT CONDUCTED AT 10 GHz (X-BAND) FOR ALL CONCRETE SPECIMENS

Concrete Specimen						
	no. 1	no. 2	no. 3	no. 4	no. 5	no. 6
Mean of $ \Gamma $	0.4873	0.4866	0.4858	0.4926	0.4911	0.4855
$\sigma_{ \Gamma }$ ($\times 10^{-3}$)	12.17	13.12	14.78	14.18	16.41	17.35

TABLE III
MEAN AND STANDARD DEVIATION OF REFLECTION COEFFICIENT MEASUREMENT CONDUCTED AT 3 GHz (S-BAND) FOR ALL CONCRETE SPECIMENS

Concrete Specimen						
	no. 1	no. 2	no. 3	no. 4	no. 5 no.	6
Mean of $ \Gamma $	0.5295	0.5244	0.5209	0.5132	0.5110	0.4982
$\sigma_{ \Gamma }$ ($\times 10^{-3}$)	8.06	6.54	6.548	8.86	5.95	5.55

reflected signal to possess a Gaussian distribution [17]. As the volumetric concentration of coarse aggregate in the specimen increases (i.e., higher (ca/c) ratio) for samples with the same (w/c) and (s/c) ratios, the scattering from the coarse aggregate is expected to increase as well. The corresponding increase in the standard deviation of the measured magnitude of the reflection coefficient shown in Table II clearly corroborates this fact.

The results of these measurements are very encouraging. First, the statistical distribution of the measured $|\Gamma|$ at 10 GHz (X-band) follows a Gaussian distribution. *A priori* knowledge of the statistical distribution of a random event greatly enhances the implementation of a decision process (i.e., maximum likelihood scheme) for determining the constituent make-up of the random event [18]. Consequently, the knowledge of the statistical distribution of the measured magnitude of $|\Gamma|$ for concrete can provide information about its (ca/c) ratio. Additionally, per a given (s/c) ratio, there seems to be a linear trend between the standard deviation of reflection coefficient and the (ca/c) ratio, irrespective of the (w/c) ratio as indicated in Table II. This indicates that if one is only interested in concrete specimens with (s/c) ratio of 1.5 and 3/8in-grade aggregate (a common mixture in many practical applications), the determination of (ca/c) is a straightforward task using this approach.

B. S-Band Measurement Results

Again for brevity, Fig. 3(a) presents the pdf of the 20 measurements conducted for specimen no. 6 at 3 GHz (S-band) in histogram form. As for the measurements conducted at 10 GHz, the measured mean and standard deviation of $|\Gamma|$ for all specimens at 3 GHz are presented in Table III. At this frequency the dielectric properties of these specimens were also measured, resulting in an average value of $(4 - j0.5)$ [3]. This shortens the wavelength of 60 mm in free-space, to approximately 30 mm in these specimens. Comparing the aggregate size of 9.5 mm (3/8in-grade) with this wavelength, it is expected that the scattering produced by the aggregate will be less compared to 10 GHz. Previous measurements conducted at this frequency provided information about the background material (i.e., cement paste which is an indication of (w/c) ratio), more so than the aggregate content [3], [8], [9]. The pdf for these measurements

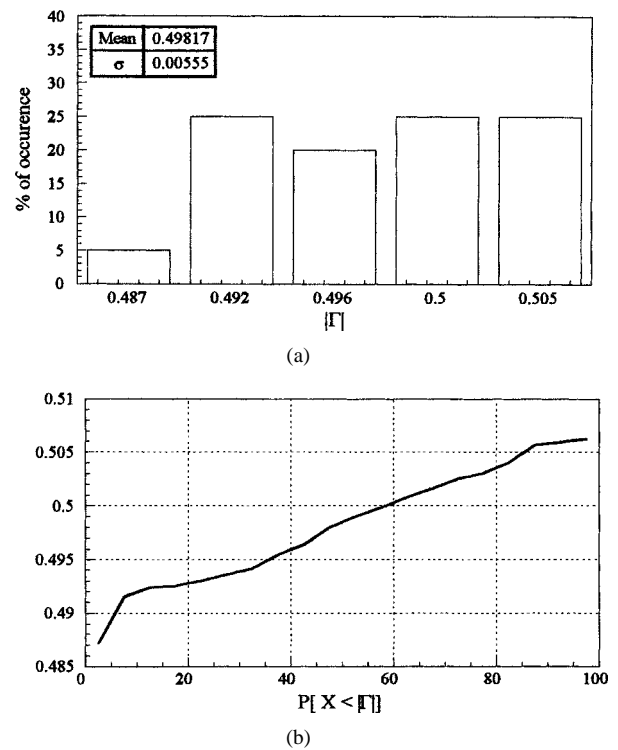

Fig. 3. (a) Histogram of the magnitude of reflection coefficient (20 measurements) at 3 GHz (S-band) for a concrete specimen possessing $w/c = 0.60$, $s/c = 1.5$ and $ca/c = 2.0$. (b) Cumulative distribution function of the magnitude of reflection coefficient (20 measurements) at 3 GHz (S-band) for a concrete specimen possessing $w/c = 0.60$, $s/c = 1.5$ and $ca/c = 2.0$.

corresponds to a uniform distribution unlike the results at 10 GHz. To verify this, the cdf of the measured $|\Gamma|$ for this specimen was calculated, and subsequently plotted in Fig. 3(b). The cdf of a uniform distribution is a line whose slope indicates the minimum and maximum values of the data set. Fig. 3(b) clearly demonstrates such a characteristic trend.

Upon a closer look at Table III, we notice that the mean of magnitude of reflection coefficient is consistently higher for the specimens with lower (w/c) ratio than those with higher (w/c) ratio. This is consistent with the results of previous experiments for mortar and cement paste, which indicates the process of free water transforming into bound water and evaporation during

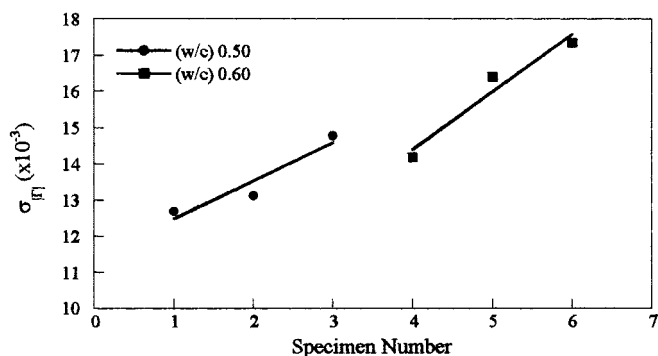

Fig. 4. Measured (discrete points) standard deviation of the magnitude of reflection coefficient at 10 GHz and linear fits (solid lines) through them as a function of (w/c) and (ca/c) ratios.

the curing process has been well documented [3], [6], [8]. These phenomena result in lower cured $|\Gamma|$ measurement as a function of higher (w/c) ratio. More importantly, there is almost no overlap between the measured mean of $|\Gamma|$ for the specimens with 0.50 (w/c) ratio and those with 0.60 (w/c) ratio. For these specimens, this will greatly facilitate the implementation of a decision process for determining the constituent make-up of a specimen from the collection of multiple measurements of $|\Gamma|$. In addition, it is very encouraging to note that the measured mean of $|\Gamma|$ remains relatively constant for a given (w/c) ratio and as a function of increasing (ca/c) ratio. As mentioned previously, this further facilitates the implementation of the decision process, for determining the constituent make-up of a concrete specimen using the statistics of previously measured specimens [3].

C. Discussion

For the set of specimens considered in this section, the measured mean of $|\Gamma|$ at 3 GHz was shown to be consistently higher for specimens with 0.50 (w/c) ratio than for those with 0.60 (w/c) ratio, when considering specimens of identical (s/c) and (ca/c) ratio. This measured mean of $|\Gamma|$ remained fairly constant as a function of (s/c) and (ca/c) ratios. Additionally, at 10 GHz the standard deviation of $|\Gamma|$, $\sigma_{|\Gamma|}$, consistently increased as a function of (ca/c) ratio for specimens of identical (w/c) and (s/c) ratios. To clearly demonstrate this, Fig. 4 shows the standard deviation of the measurements at 10 GHz for all specimens listed in Table I. The discrete points are the measured values (from Table II), and the lines are linear fits through the points for each (w/c) ratio. The results show the correlation mentioned above. Hence, the measured mean of $|\Gamma|$ at 3 GHz and standard deviation of $|\Gamma|$ at 10 GHz are shown to potentially be able to provide for an indication of (w/c) and (ca/c) ratio, respectively. The ramification of these findings is that making several measurements at two frequencies and studying the statistical distribution of their measured $|\Gamma|$ can provide valuable information about the important parameters of concrete, such as the (w/c) and the (ca/c) ratios, both of which influence its compressive strength significantly.

IV. MEASUREMENT REPEATABILITY

Since the potential follow-up to this study, as it relates to determining the constituent make-up of a concrete specimen in a

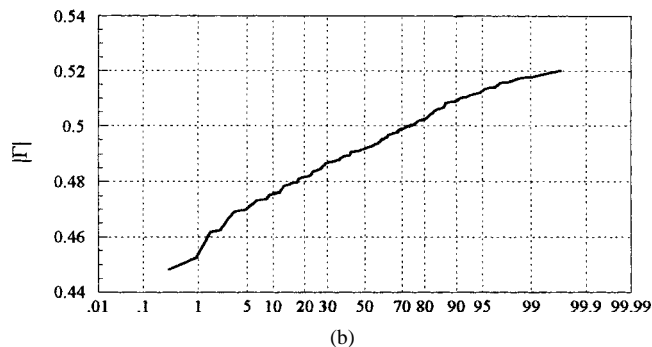
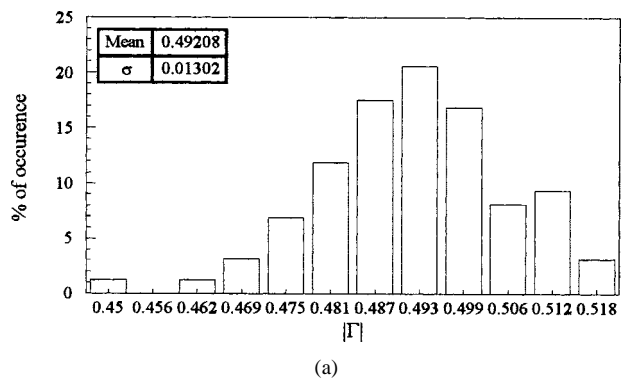

Fig. 5. (a) Histogram of the magnitude of reflection coefficient (160 measurements) at 10 GHz (X-band) for a concrete specimen possessing w/c = 0.50, s/c = 1.5 and ca/c = 1.5 produced at the Terracon Consultants Western facilities. (b) Cumulative distribution function of the magnitude of reflection coefficient (160 measurements) at 10 GHz (X-band) for the Terracon specimen.

nondestructive fashion, solely depends on the statistics of the measured magnitude of reflection coefficient from previously characterized specimens, it is imperative to determine the repeatability of the original results. The initial assumption was that because all of the measurements were considered independent of each other, even though they were obtained from a single specimen, doing so is analogous to conducting one measurement per specimen on several different specimens of the same constituent make-up. To verify this assumption, an additional concrete specimen with 0.5 (w/c) ratio, 1.5 (s/c) and 1.5 (ca/c) ratios with 3/8in-grade aggregate, was produced in the facilities of Terracon Consultants Western (a local civil engineering surveying company). The reason for producing the new specimen under the supervision of field experts was that it is fair to assume that the investigating team at Colorado State University (CSU) might not have been consistent in the way they may have produced their specimens. The pdf and cdf of these measurements at 10 GHz and 3 GHz after the 28-day curing period are presented in Figs. 5 and 6. The results of these measurements clearly follow those reported in the previous two sections. Additionally, the measured mean and standard deviation of $|\Gamma|$ are very close to the previous measurements shown in Tables II and III. This clearly demonstrates the repeatability of the measurements. To better appreciate the quality of the results, Table IV shows the results for the measured mean and standard deviation of $|\Gamma|$ for a specimen produced at CSU (CSU specimen in Table IV) with the same constituent make-up as that produced at

TABLE IV

COMPARISON BETWEEN THE MEASURED MEAN AND STANDARD DEVIATION OF MAGNITUDE OF REFLECTION COEFFICIENT MEASUREMENTS FOR THE SPECIMEN ($w/c = 0.50, s/c = 1.5$ AND $ca/c = 1.5$) PRODUCED AT COLORADO STATE UNIVERSITY AND THE SPECIMEN PRODUCED AT TERRACON CONSULTANTS WESTERN FACILITIES

	10 GHz (X-band)		3 GHz (S-Band)	
	CSU Specimen	Terracon Specimen	CSU Specimen	Terracon Specimen
Mean($ \Gamma $)	0.4866	0.4921	0.5244	0.5217
$\sigma_{ \Gamma }$ ($\times 10^{-3}$)	13.12	13.02	6.54	8.91

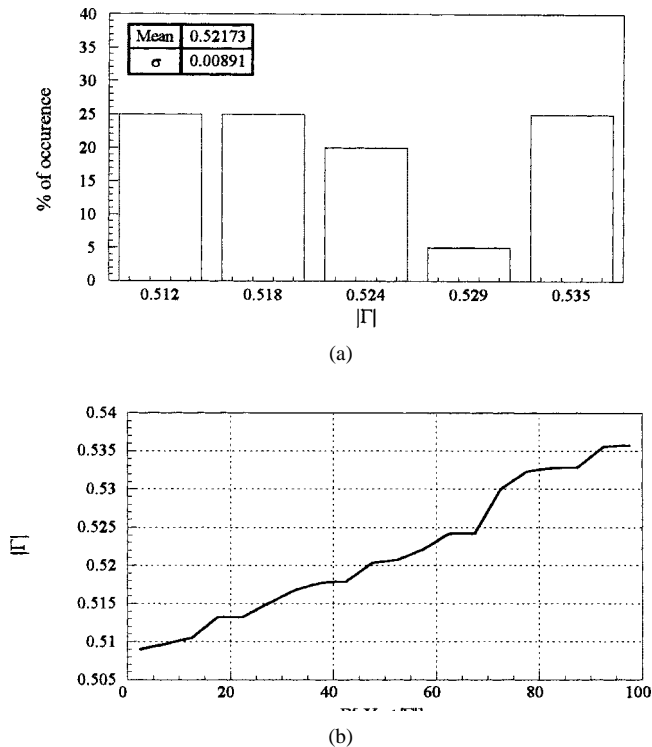

Fig. 6. (a) Histogram of the magnitude of reflection coefficient (20 measurements) at 3 GHz (S-band) for the concrete specimen possessing $w/c = 0.50, s/c = 1.5$ and $ca/c = 1.5$ produced at the Terracon Consultants Western facilities. (b) Cumulative distribution function of the magnitude of reflection coefficient (20 measurements) at 3 GHz (S-band) for the Terracon specimen.

the Terracon Consultant Western facilities (Terracon specimen in Table IV).

Except for the small variation in the value of $\sigma_{|\Gamma|}$ at 3 GHz, all the measurements are almost identical. Furthermore, this small difference is not a concern since at this frequency the mean, not the standard deviation, of the measured $|\Gamma|$ is correlated to the (w/c) ratio of the specimen. Therefore, relatively small variations in this parameter are not as critical as they would be at 10 GHz, which is used for (ca/c) ratio determination.

V. CONCLUSION

In this paper, the statistical distributions of near-field microwave reflection property measurement of concrete with varying constituent make-up were conducted at 10 GHz and 3 GHz. These measurements were conducted using OERW probes in contact with specially prepared concrete specimens. It was shown that the statistical distribution of the measured

magnitude of reflection coefficient, $|\Gamma|$, corresponds to the well-known Gaussian and uniform distributions, respectively. Additionally, it was shown that for the studied set of specimens, the aggregate content; namely, the (ca/c) ratio, can be correlated to the standard deviation of the measured $|\Gamma|$ at 10 GHz. Similarly, at 3 GHz the measured mean of $|\Gamma|$ was shown to be correlated to the (w/c) ratio. These results agree with the understanding that at higher microwave frequencies the multiple scattering from the coarse aggregate is significantly higher than that at lower frequencies. This results in the trend that shows more point-to-point measurement variations at higher frequencies than at lower frequencies.

The knowledge of (w/c) and (ca/c) ratios is very important since these two parameters significantly influence the compressive strength of concrete. Having now determined the statistical distributions of the measured $|\Gamma|$ for various concrete specimens, one may employ a simple decision process algorithm for determining the constituent make-up of a concrete specimen. Using the measured statistical properties of concrete specimens possessing different constituent make-ups, the outcome of several measurements of the reflection coefficient on an unknown specimen can be correlated to its material composition, more importantly to its compressive strength, either through a look-up table of actual measurements conducted on cylindrical specimens or established Civil Engineering formulae.

ACKNOWLEDGMENT

The authors would like to thank Dr. P. Nowak of the Civil Engineering Department at Gonzaga University, Spokane, WA, for his valuable help in the selection of the concrete mixtures, and for his advice for the mixing protocols. The authors would also like to thank Terracon Consultants Western (M. Walker, Manager of Construction Service) for the use of their facilities and their help in making the independent specimen.

REFERENCES

- [1] V. M. Malhotra and N. J. Carino, Eds., *Handbook on Nondestructive Testing of Concrete*. Boca Raton, FL: CRC, 1991.
- [2] "Concrete Core Testing for Strength," Concrete Society, London, U.K., Tech. Rep. 11, 1976.
- [3] K. J. Bois, "Near-field microwave inspection and characterization of cement based materials," Ph.D. dissertation, Elect. Comput. Eng. Dept., Colorado State Univ., Ft. Collins, Jan. 1999.
- [4] S. H. Kosmatka and W. C. Panarese, *Design and Control of Concrete Mixtures*, 13th ed. Skokie, IL: Portland Cement Assoc., 1988.
- [5] D. A. Abrams, "Design of Concrete Mixtures," Structural Materials, Research Laboratory, Lewis Institute, Chicago, Bull. 1, 1918.

- [6] R. Zoughi, S. D. Gray, and P. S. Nowak, "Microwave nondestructive estimation of cement paste compressive strength," *ACI Mater. J.*, vol. 92, no. 1, Jan.–Feb. 1995.
- [7] W. Shalaby and R. Zoughi, "Analysis of monopole sensors for cement paste compressive strength estimation," *Res. Nondestruct. Eval.*, vol. 7, no. 2/3, pp. 101–105, 1995.
- [8] K. J. Bois, A. D. Benally, P. S. Nowak, and R. Zoughi, "Cure-state monitoring and water-to-cement ratio determination of fresh portland cement based materials using near field microwave techniques," *IEEE Trans. Instrum. Meas.*, vol. 47, no. 3, pp. 628–637, June 1998.
- [9] K. A. Bois, A. Benally, P. S. Nowak, and R. Zoughi, "Microwave non-destructive determination of sand to cement (s/c) ratio in mortar," *Res. Nondestruct. Eval.*, vol. 9, no. 4, pp. 227–238, 1997.
- [10] K. Bois, R. Mirshahi, and R. Zoughi, "Dielectric mixing models for cement based materials," in *Proceedings of the Review of Progress in Quantitative NDE*. New York: Plenum, 1997, vol. 16A, pp. 657–663.
- [11] R. Zoughi, G. L. Cone, and P. S. Nowak, "Microwave nondestructive detection of rebars in concrete slabs," *Mater. Eval.*, vol. 49, no. 11, pp. 1385–1388, Nov. 1991.
- [12] R. Zoughi, T. Nast, and P. S. Nowak, "Preliminary results of microwave reflectometry as a nondestructive tool for studying concrete properties," in *Proc. Conf. Nondestructive Evaluation of Civil Structures and Materials*, Boulder, CO, May 10–13, 1992, pp. 339–343.
- [13] K. Bois, H. Campbell, A. Benally, P. S. Nowak, and R. Zoughi, "Microwave noninvasive detection of grout in Masonry," *Masonry Soc. J.*, vol. 16, no. 1, pp. 49–54, 1998.
- [14] A. F. Stock, D. J. Hannant, and R. I. T. Williams, "The effect of aggregate concentration upon the strength and modulus of elasticity of concrete," *Mag. Concrete Res.*, vol. 31, no. 109, pp. 225–234, 1979.
- [15] A. M. Neville, *Properties of Concrete*, 4th ed: Wiley, 1996.
- [16] N. Qaddoumi, "Microwave detection and characterization of sub-surface defect properties in composites using an open ended rectangular waveguide," Ph.D. dissertation, Colorado State Univ., Ft. Collins, Feb. 1998.
- [17] F. T. Ulaby, R. K. Moore, and A. K. Fung, *Microwave Remote Sensing, Active and Passive*. Norwood, MA: Artech House, 1998, vol. II.
- [18] H. L. Van Trees, *Detection, Estimation, and Modulation Theory: Part I*. New York: Wiley, 1968, ch. 2, pp. 23–52.



Karl J. Bois (M'93) received the B.Sc. and M.Sc. degrees in electrical engineering from the Université Laval, Quebec, P.Q., Canada, in 1993 and 1995, respectively, and the Ph.D. degree in electrical engineering from Colorado State University, Fort Collins, in 1999.

From 1995 to 1999, while at the Applied Microwave Nondestructive Testing Laboratory at Colorado State University, his main areas of research involved microwave nondestructive characterization of cement based materials, developing new techniques for measuring the electrical properties of materials, and exploring novel theoretical formula for the near-field characteristics of OERW's. He is currently working for Hewlett-Packard Company's Chip Packaging gGroup associated with the System VLSI Technology Center (SVTC), Fort Collins. His main functions include EMI and signal integrity modeling efforts for next generation computer chip packages, and implementing test benches for experimental verification.



Aaron D. Benally received the B.Sc. degree in electrical engineering from Colorado State University, Fort Collins, in 1999.

He is currently with Colorado State University, where he is conducting research in nondestructive inspection and monitoring of concrete structures using microwave near-field techniques.

Mr. Benally is a member of the Navajo Nation in New Mexico.



Reza Zoughi (S'85–M'86–SM'93) received the B.S.E.E., M.S.E.E., and Ph.D. degrees in electrical engineering (radar remote sensing, radar systems, and microwaves) from the University of Kansas, Lawrence.

From 1981 to 1987, he was with the Radar Systems and Remote Sensing Laboratory at the University of Kansas in various capacities. Since 1987, he has been with Colorado State University, Fort Collins, where he is a Professor of Electrical and Computer Engineering, and has established the Applied Microwave Nondestructive Testing Laboratory (AMNTL). His current areas of research include nondestructive testing of material using microwaves, developing new techniques for microwave and millimeter-wave inspection and testing of materials, and developing new electromagnetic probes to measure characteristic properties of material at microwave frequencies. He has to his credit over 220 journal publications, conference presentations and proceedings, technical reports, and overview articles in the fields of radar remote sensing and microwave nondestructive evaluation. He is the author of graduate textbook *Microwave Nondestructive Testing and Evaluation Principles* (Norwell, MA: Kluwer). He is also the coinventor on five patents in the field of microwave nondestructive testing and evaluation. He has been voted the most outstanding teaching faculty seven times by the junior and senior students at the Electrical and Computer Engineering Department at Colorado State University. He has also been recognized as an honored researcher four times by the Colorado State University Research Foundation.

Dr. Zoughi was the recipient of the Dean's Council Award in 1992, and the Abell Faculty Teaching Award in 1995. He is also the Business Challenge Endowment Associate Professor of Electrical and Computer Engineering (1995–1997). He was the 1996 recipient of the Colorado State Board of Agriculture Excellence in Undergraduate Teaching Award. He is a senior member of Sigma Xi, Eta Kappa Nu and the American Society for Nondestructive Testing (ASNT). He is an Associate Technical Editor for *Materials Evaluation* and IEEE TRANSACTIONS ON INSTRUMENTATION AND MEASUREMENT, and served as the Guest Associate Editor for the *Special Microwave NDE Issue of Research in Nondestructive Evaluation* in 1995 and the *Special Microwave Issue of Materials Evaluation* in 1994.