

01 Dec 2008

Fully Evolvable Optimal Neurofuzzy Controller Using Adaptive Critic Designs

Salman Mohagheghi

Ganesh K. Venayagamoorthy
Missouri University of Science and Technology

Ronald G. Harley

Follow this and additional works at: https://scholarsmine.mst.edu/ele_comeng_facwork



Part of the [Electrical and Computer Engineering Commons](#)

Recommended Citation

S. Mohagheghi et al., "Fully Evolvable Optimal Neurofuzzy Controller Using Adaptive Critic Designs," *IEEE Transactions on Fuzzy Systems*, Institute of Electrical and Electronics Engineers (IEEE), Dec 2008. The definitive version is available at <https://doi.org/10.1109/TFUZZ.2008.925910>

This Article - Journal is brought to you for free and open access by Scholars' Mine. It has been accepted for inclusion in Electrical and Computer Engineering Faculty Research & Creative Works by an authorized administrator of Scholars' Mine. This work is protected by U. S. Copyright Law. Unauthorized use including reproduction for redistribution requires the permission of the copyright holder. For more information, please contact scholarsmine@mst.edu.

Fully Evolvable Optimal Neurofuzzy Controller Using Adaptive Critic Designs

Salman Mohagheghi, *Member, IEEE*, Ganesh K. Venayagamoorthy, *Senior Member, IEEE*,
and Ronald G. Harley, *Fellow, IEEE*

Abstract—A near-optimal neurofuzzy external controller is designed in this paper for a static compensator (STATCOM) in a multimachine power system. The controller provides an auxiliary reference signal for the STATCOM in such a way that it improves the damping of the rotor speed deviations of its neighboring generators. A zero-order Takagi–Sugeno fuzzy rule base constitutes the core of the controller. A heuristic dynamic programming (HDP) based approach is used to further train the controller and enable it to provide nonlinear near-optimal control at different operating conditions of the power system. Based on the connectionist systems theory, the parameters of the neurofuzzy controller, including the membership functions, undergo training. Simulation results are provided that compare the performance of the neurofuzzy controller with and without updating the fuzzy set parameters. Simulation results indicate that updating the membership functions can noticeably improve the performance of the controller and reduce the size of the STATCOM, which leads to lower capital investment.

Index Terms—Adaptive critic designs, connectionist systems theory, evolving fuzzy systems, neurofuzzy systems, optimal control.

I. INTRODUCTION

FUZZY SYSTEMS have been used in many engineering applications. These heuristic based intelligent techniques can effectively perform as nonlinear identifiers and/or controllers in the presence of noise and uncertainties, and provide partially robust solutions [1]. Fuzzy systems have been extensively used in power system applications for pattern recognition, identification, modeling, and control [2], [3]. Based on the type of the crisp input applied to the controller (error, derivative of the error, or the integral of the error), the fuzzy controller can perform as a nonlinear proportional, derivative, or integrator controller. In general, fuzzy controllers can be viewed as nonlinear gain scheduling controllers. They provide a nonlinear mapping from

a set of crisp inputs to a set of fuzzy values using fuzzification techniques, and back to a set of crisp outputs using defuzzification techniques [4].

Fuzzification is a very important part of the fuzzy control process. Different standard or nonstandard functions, called *fuzzifiers*, can be used for mapping crisp values to fuzzy values. Standard fuzzifiers such as the *singleton* and *nonsingleton*, e.g., *Gaussian* and *triangular*, are the most commonly used functions. However, in general, there does not exist a systematic way for selecting the proper membership functions for a given problem.

Due to simplicity, most researchers tend to design the input/output fuzzy sets using the equal-span standard functions. However, these functions do not necessarily provide the optimum solution for all problems. Instead, *a priori* knowledge of the plant to be controlled and its dynamics might lead to different standard or nonstandard fuzzy membership functions with various physical shapes in order to design a more efficient fuzzy logic controller.

Clearly, changing any of the parameters associated with a fuzzy controller can change its performance. However, it has been shown that altering the membership functions has a dominant effect [5]. Many researchers have tried to address this issue by applying partitioning techniques for the input/output space [6], [7]. Others have proposed methods to take the uncertainty of the membership functions into account [8], [9].

There have also been several attempts to update the fuzzy rule base in order to be able to respond to the changes in the system dynamics. Angelov [10] proposed evolving fuzzy-rule-based models by using the information from the new data samples. In this approach, the rule base is modified by adding new rules if significant information exists in the new data collected that had not been covered before [10], [11].

However, it has also been shown in the literature that the connectionist systems theory can be applied to adaptively adjust the parameters of a fuzzy controller, including its membership functions, while the controller is operating in the system [6], [12]–[15]. This approach has been the most common technique for nonlinear control applications using evolvable fuzzy systems [16]–[19]. Most of these evolvable fuzzy control schemes in the literature use an adaptive scheme in which the parameters of the controller are adjusted, based on the value of the error at one time step ahead. Clearly, this scheme suffers from being “short-sighted,” since the parameters that minimize the error at one step ahead do not necessarily lead to optimal performance over the long run [20]. Indeed, these adaptive schemes might at times cause inappropriate control effort by the controller.

Manuscript received May 31, 2007; revised August 26, 2007, October 22, 2007, and December 28, 2007; accepted January 19, 2008. First published May 23, 2008; current version published December 19, 2008. This work was supported in part by the National Science Foundation (NSF), USA under Grant ECS 0400657 and Grant ECS 0348221, and in part by the Duke Power Company, Charlotte, NC.

S. Mohagheghi was with the School of Electrical and Computer Engineering, Georgia Institute of Technology, Atlanta, GA 30332 USA. He is now with ABB, Inc., U.S. Corporate Research Center, Raleigh, NC 27606 USA (e-mail: salman.mohagheghi@us.abb.com).

G. K. Venayagamoorthy is with the Real-Time Power and Intelligent Systems Laboratory, Department of Electrical and Computer Engineering, Missouri University of Science and Technology, Rolla, MO 65409 USA (e-mail: gkumar@ieee.org).

R. G. Harley is with the Intelligent Power Infrastructure Consortium (IPIC), School of Electrical and Computer Engineering, Georgia Institute of Technology, Atlanta, GA 30332 USA and also with the University of KwaZulu-Natal, Durban 4041, South Africa (e-mail: rharley@ece.gatech.edu).

Digital Object Identifier 10.1109/TFUZZ.2008.925910

The focus of this paper is on the design of a near-optimal neural-network-based fuzzy (neurofuzzy) controller by optimally adjusting its antecedent membership functions and consequent (output) parameters. The adaptive critic designs (ACDs) theory, based on combined concepts of approximate dynamic programming (ADP) and reinforcement learning, is used, which can provide a near-optimal control policy over an infinite horizon of a problem in the presence of noise and uncertainties [21]. The novel approach proposed in this paper allows for designing a fully evolvable near-optimal fuzzy controller without having access to any mathematical model of the system, with no prior information on the system dynamics, and without any large amount of offline data.

The proposed controller in this paper is designed for supervisory level control of a static compensator (STATCOM) in a multimachine power system. Nevertheless, the design procedure presented here is not problem-dependent and can be applied to various control applications. This specific control application is intentionally selected in this paper to show the superiority of evolvable fuzzy controllers, since the selected system portrays a nonlinear nonstationary system with parameter uncertainties and fast changing dynamics whose mathematical model cannot be obtained easily. In such an application, linear controllers lose their efficiency due to the ever-changing nature of the system. Designing nonlinear controllers, on the other hand, is not easy due to the lack of an analytical model available for the system. Several researchers have proposed fuzzy logic [22]–[24], neural networks [25]–[27], or neurofuzzy systems [28] for designing controllers for the STATCOM. Many of these adaptive techniques use only the error at one time step ahead that, as mentioned before, makes them short-sighted, causing them to generate excessive control effort. Optimal control techniques can be employed to solve this problem [20]. The major advantage of the optimal fuzzy-logic-based controller proposed in this study over the similar neural-networks-based approaches is its “white box” nature. As opposed to a neurocontroller, the rule base of a fuzzy-logic-based controller provides a heuristic reasoning for controlling the plant. Hence, the design engineer has a clear understanding of the parameters and their effects on the system performance. In other words, similar to the analytical approaches, the input–output relationship in a fuzzy controller can be explained in terms of the physical rules governing the behavior of the system. Table I summarizes the main advantages and disadvantages of the conventional and intelligent control schemes for the STATCOM.

In an earlier work in [37], the authors designed a near-optimal neurofuzzy controller for the STATCOM using partial updating of the output parameters only. This paper extends the previous work by applying a full updating scheme in which the antecedent fuzzy sets are also adjusted to provide optimal control. Simulation results are provided that point out the superiority of the latter scheme.

The rest of the paper is organized as follows. Section II summarizes some of the key concepts behind ACD-based controllers. The structure of the multimachine power system and the external control scheme for the STATCOM appear in Section III of the paper. The structure of the proposed STATCOM neuro-

TABLE I
CONVENTIONAL AND INTELLIGENT CONTROL SCHEMES FOR A STATCOM

Type	Ref.	Operating Point Dependent	Needs Model	Short Sighted	Flexible Structure	White Box
PI	[29]–[32]	Yes	Not Essential	N/A	No	Yes
ANL ¹	[33]–[36]	No	Yes	N/A	Sometimes	Sometimes
FFC ¹	[22], [24]	No	No	N/A	No	Yes
AFC ¹	[24], [28]	No	No	Yes	Yes	Yes
ANC ¹	[25], [26]	No	No	Yes	Yes	No
ONC ¹	[27]	No	No	No	Yes	No
OFC ¹	Current	No	No	No	Yes	Yes

¹ANL: analytical nonlinear controller, FFC: fuzzy logic controller with fixed parameters, AFC: fuzzy logic controller with adaptive structure, ANC: neurocontroller with adaptive structure, ONC: optimal neurocontroller, OFC: optimal fuzzy controller.

fuzzy external controller is explained in Section IV. Section V provides the details of the training process required for the proposed controller. Simulation results are provided in Section VI in order to compare the effectiveness of the proposed neurofuzzy external controller with and without full updating. Some practical considerations are discussed in Section VII. Finally, the concluding remarks are given in Section VIII.

II. ADAPTIVE CRITIC DESIGNS (ACDs)

Adaptive critic designs (ACDs) were first introduced by Werbos in [38] and later in [39], and by Widrow in the early 1970s [40]. Werbos later on proposed a family of ADP designs [21]. These are neural-network-based techniques capable of optimizing a measure of utility or goal satisfaction over multiple time periods into the future, in a nonlinear environment under conditions of noise and uncertainty.

A utility function $U(t)$ along with an appropriate choice of a discount factor is defined for the ACD controller. At each time step t , the plant outputs (a set of measured variables) $X(t)$ are fed into the controller, which in turn generates a control signal $A(t)$ in such a way that it optimizes the expected value of the utility function U over the horizon time of the problem. This quantity is referred to as the *cost-to-go function* J given by Bellman’s equation of dynamic programming [41] as follows:

$$J(t) = \sum_{k=0}^{\infty} \gamma^k U(t+k) \quad (1)$$

where γ is a discount factor, $0 < \gamma < 1$, for infinite (k goes to ∞) and finite (k goes to N) horizon problems. A discount factor of zero uses the present value of the utility function as the optimization objective (same as minimization of the error at one step ahead), while a discount factor of unity considers all the future values of the utility function equally important. An infinite horizon problem has infinite states, while when the discount factor is less than 1, the number of future states is no longer infinite since after a point, their contributions will become insignificant in the value of the function J .

Fundamentally, ACD-based controllers are based on three mathematical concepts: approximate dynamic programming, optimal control, and reinforcement learning. It is known that dynamic programming is the only exact technique available to

solve the problem of optimization over time in a general non-linear, stochastic system [41]. However, in practice, it is used in very limited applications, due to its computational complexities [42]. The ACD theory overcomes this problem by approximating the cost-to-go function $J(t)$ —thus, the name approximate dynamic programming. Essentially, ACD theory creates reinforcement learning systems by building systems that learn to approximate the Bellman’s equation of dynamic programming in (1) [20]. A critic neural network accomplishes this task by approximating the true cost-to-go function $J(t)$ with no prior knowledge of the system. Moreover, it avoids the curse of dimensionality that occurs in some cases of classical dynamic-programming-based optimal control [41]. Clearly, the critic neural network approximates the function $J(t)$ in an unsupervised fashion, since the desired control trajectory is not known in advance. The estimated cost-to-go function is then used as a performance measure in order to reward or penalize the controller.

Two major categories of the ACD family include the model-based ACD designs, where a model of the plant to be controlled is required in order to train the controller, and the action-dependent ACD (ADACD) designs, which takes a model-independent approach. The action-dependent heuristic dynamic programming (ADHDP) ACD approach is chosen for the study in this paper, which includes two different neural networks as follows:

- 1) *critic neural network*: A neural network trained to approximate the cost-to-go function J required for optimization;
- 2) *neurofuzzy controller (action neural network)*: This neural network functions as a controller and is trained to provide the optimal control signals to the STATCOM, resulting in minimization/maximization of the function J over the time horizon of the problem.

In theory, if the weights of the critic network have converged to the correct values [the values that satisfy the Bellman’s equation of optimality in (1)], then the cost-to-go function $J(t)$ serves as a Lyapunov function guaranteed to stabilize the overall system if the system is controllable [20]. Furthermore, if the action network is sufficiently trained using the signals provided by the critic network, then it is guaranteed to provide near-optimal solutions by performing approximate dynamic programming [42].

III. CASE STUDY: STATCOM IN A MULTIMACHINE POWER SYSTEM

Fig. 1 illustrates the schematic diagram of the 12-bus benchmark power system with a STATCOM. The power system is a 12-bus three-generator network designed for evaluating the effects of flexible AC transmission system (FACTS) devices at the transmission level [43]. The original system has low voltages at buses 4 and 5. Preliminary simulation results by the authors showed that installing a STATCOM at bus 4 can drastically improve the voltage profile of the whole network [44]. The STATCOM is controlled by two so-called internal PI controllers, one for regulating the line voltage (PI_V) and the other for regulating the dc link voltage (PI_{dc}). The details of the STATCOM PI controllers have been discussed in [37].

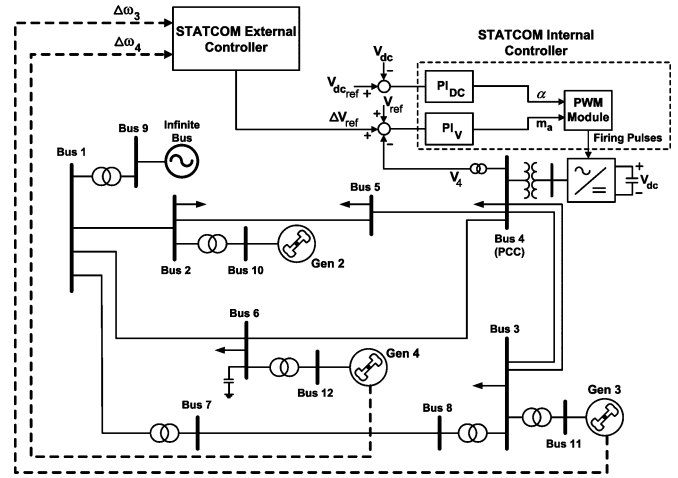

Fig. 1. Schematic diagram of the 12-bus power system with a STATCOM.

A. STATCOM External Control

The STATCOM is a shunt connected FACTS device that can control the voltage and/or the reactive power exchange with the network at the point of connection to the power system, i.e., the point of common coupling (PCC) [45]. In addition to regulating the voltage and/or power during the steady-state conditions, with the proper control structure, the STATCOM is capable of improving the damping of the power system during dynamic and transient disturbances [45], [46]. This can be achieved by providing an additional external control loop that sends an auxiliary control signal to the STATCOM in order to control it from a supervisory level.

Most of these proposed external controllers employ a linear control scheme in the form of a simple proportional gain or a PI controller [45]–[47]. However, the efficacy of the linear external controller can be largely affected by a change in the operating conditions of the power system or its topology. The situation can be worsened as the complexities of the power system to which the STATCOM is connected increase. In an earlier work in [37], the authors showed that a linear controller fine-tuned at a certain operating condition is not able to effectively damp out the oscillations in the power system.

B. Proposed External Controller

The external controller proposed in this paper provides an auxiliary control signal ΔV_{ref} for the line voltage controller (PI_V) reference signal (Fig. 1). The control objective of the external controller is to provide additional damping for the two generators neighboring the STATCOM, i.e., generators 3 and 4. In order to achieve this, the controller uses the rotor speed measurements of generators 3 and 4 as inputs and provides an output that positively damps both generators. Generator 2 is close to the infinite bus, and the simulation results indicate that it is not significantly affected by the STATCOM.

Generators 3 and 4 have inertia constants of 3.0 and 5.0 MW·s/MVA, respectively, which result in the local swings with frequencies of approximately 1 Hz for generator 3 and 0.8 Hz for generator 4. The fact that generators 3 and 4 oscillate at

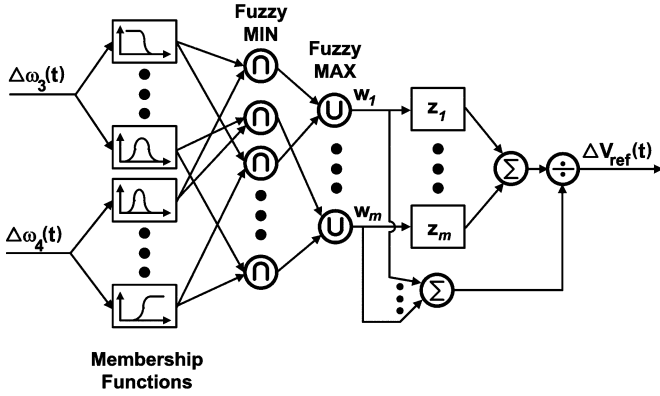

Fig. 2. Schematic diagram of the neurofuzzy external controller.

different frequencies complicates the external control scheme, and makes a linear controller less effective [37], since the auxiliary control signal ΔV_{ref} that is suitable to damp generator 3, for example, might at times exacerbate the dynamic oscillations of the rotor of generator 4 and vice versa.

This problem can be solved by using an intelligent external control scheme, in which this controller exerts a control action while watching its effect on the overall performance of the power system. An ACD-based neurofuzzy controller is an excellent candidate for such a control scheme because of the following.

- 1) The relatively low number of inputs and outputs allows the creation of an effective fuzzy rule base for the controller.
- 2) Introduction of neural networks enables the controller to perform in a near-optimal way by evaluating the effects of its control actions on the response of the power system, and updating the controller parameters accordingly.

In a typical neurofuzzy system, the parameters of the fuzzy controller, such as the fuzzy set membership functions and the consequent rules, are considered the synaptic weights of a connectionist learning system. Neural-network-based learning techniques are then applied in order to adjust these parameters based on the performance of the system. Fig. 2 illustrates the schematic diagram of the neurofuzzy controller for the STATCOM [6], with the fuzzy membership functions and the fuzzy Min/Max operators as the nonlinear activation functions of the neurons.

IV. ACD NEUROFUZZY EXTERNAL CONTROLLER STRUCTURE

Fig. 3 shows the schematic diagram of the proposed ACD-based neurofuzzy external controller for the STATCOM. The entire system of Figs. 1–3 is simulated in the power system computer aided design/electromagnetic transients program for dc (PSCAD/EMTDC) environment. A simulation step size of $50 \mu\text{s}$ is selected, while the sampling time for training the external controller is 2.0 ms (500 Hz).

The plant in Fig. 3 consists of the multimachine power system in Fig. 1, the STATCOM, and the PI_{dc} controller. The input to the plant is the modulation index m_a generated by the PI_V controller; and its output $X(t)$ is the vector of the speed deviations of generators 3 and 4. The proposed external controller consists of two main components: the neurofuzzy controller (Fig. 2) and

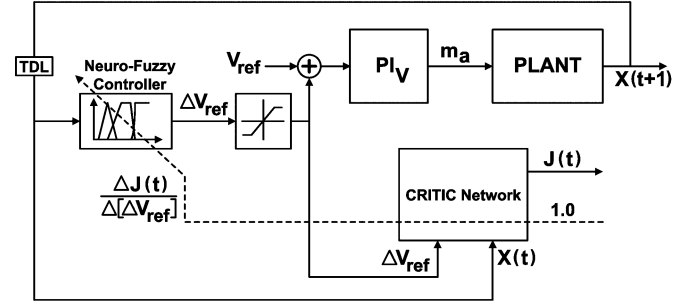

Fig. 3. Schematic diagram of the STATCOM ACD-based neurofuzzy external controller.

 TABLE II
NEUROFUZZY CONTROLLER RULE BASE

Input Fuzzy Variables	$\Delta\omega_4$					
	NB	NS	Z	PS	PB	
$\Delta\omega_3$	NB	PB	PM	PM	PS	Z
	NS	PM	PM	PS	Z	NS
	Z	PM	PS	Z	NS	NM
	PS	PS	Z	NS	NM	NM
	PB	Z	NS	NM	NM	NB

a critic neural network, which is trained to approximate the cost-to-go function J (Fig. 3).

A. Neurofuzzy Controller

The heart of the neurofuzzy controller is the fuzzy inference system. A zero-order Takagi–Sugeno fuzzy model, which is a special case of the Mamdani model [6], is used for implementing the controller. The input to the neurofuzzy controller is the vector of the selected states of the power system as in (2):

$$X(t) = [\Delta\omega_3(t), \Delta\omega_4(t)]^T. \quad (2)$$

The controller, in return, generates a control signal ΔV_{ref} , which is added to the line voltage reference of the local PI_V controller (Fig. 1). At steady state, the PI_V has a line voltage reference of 1.0 per unit (p.u.). Therefore, the output of the neurofuzzy controller is clamped at ± 0.05 p.u., such that the voltage at bus 4 does not fall outside the acceptable range of [0.95, 1.05] p.u.

Five membership functions are considered in Fig. 2 for the rotor speed deviations of each generator, which are associated with the fuzzy terms *negative big*, *negative small*, *zero*, *positive small*, and *positive big*, while the output variable ΔV_{ref} has seven fuzzy membership functions associated with it, namely *negative big*, *negative medium*, *negative small*, *zero*, *positive small*, *positive medium*, and *positive big*. These fuzzy sets generate a rule base with 25 rules for the neurofuzzy controller, as shown in Table II.

Gaussian membership functions are used for each fuzzy input variable. The membership degree of variable x in the fuzzy set A_j can be expressed as

$$\mu_{A_j}(x) = \exp\left[-\frac{1}{2}\left(\frac{x - m_j}{\sigma_j}\right)^2\right] \quad (3)$$

where m_j and σ_j are the corresponding center and the width of the fuzzy set, respectively. Singleton fuzzy sets are assigned

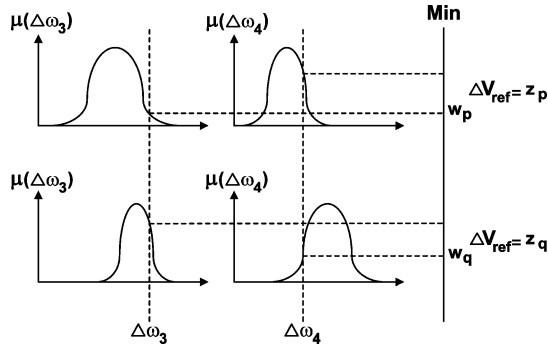

Fig. 4. Fuzzy inference mechanism used for the neurofuzzy controller.

to the fuzzy output variable, where the membership degree at a certain singleton point z_k is unity, but zero otherwise:

$$\mu_{z_k}(z) = \begin{cases} 1, & z = z_k \\ 0, & \text{otherwise.} \end{cases} \quad (4)$$

In general, for the multi-input–single-output (MISO) controller designed in this paper, each fuzzy rule can be expressed as follows:

If $\Delta\omega_3$ is A_i **and If** $\Delta\omega_4$ is B_j **Then** ΔV_{ref} is z_k .

The zero-order Takagi–Sugeno fuzzy model is used for the fuzzy inference mechanism. The Min function is used for the fuzzy AND operator (Fig. 4).

The final crisp output of the controller is derived using the centroid defuzzifier [4]. Therefore, the output of the controller can be expressed as

$$\Delta V_{\text{ref}}(t) = \frac{\sum_n w_n z_n}{\sum_n w_n} \quad (5)$$

where w_n is the firing strength of the n th rule and z_n is the value of the antecedent corresponding to the n th rule.

B. Critic Network

The parameters of the neurofuzzy controller are derived in such a way that it performs well over a range of operating conditions and during different faults. This is also partly ensured by the inherent robustness of the fuzzy controller. However, the performance is still far from optimal, and therefore, the controller is further trained so that it can perform optimal control of the plant over the time horizon of the problem. For this purpose, a critic network is trained to learn the cost-to-go function J associated with the power system. In other words, it evaluates how well the neurofuzzy controller is doing from moment to moment. Once sufficiently trained, the critic network can, in turn, provide the appropriate training signal for the controller.

The utility function for the critic network comprises two terms (decomposed utility function):

$$U(t) = U_1(t) + U_2(t) \quad (6)$$

where

$$U_1(t) = |\Delta\omega_3(t) + \Delta\omega_3(t-1) + \Delta\omega_3(t-2)| \quad (7)$$

$$U_2(t) = |\Delta\omega_4(t) + \Delta\omega_4(t-1) + \Delta\omega_4(t-2)|. \quad (8)$$

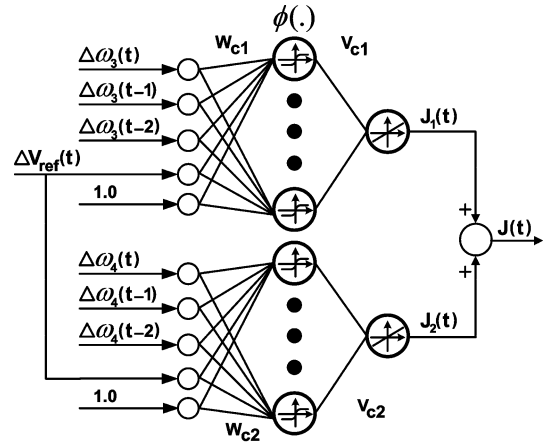

Fig. 5. Schematic diagram of the critic network.

The two terms are necessary because the rotors of generators 3 and 4 have different swings, and therefore, the STATCOM should try to improve the performance of both generators at the same time. The cost-to-go function estimated by the critic network is

$$J(t) = \sum_{i=0}^{\infty} \gamma^i U(t+i). \quad (9)$$

This can be further simplified as

$$J(t) = \sum_{i=0}^{\infty} \left(\sum_{k=1}^2 \gamma^i U_k(t+i) \right) = \sum_{k=1}^2 J_k(t). \quad (10)$$

Two subcritic networks are therefore used, where each one learns one part of the cost-to-go function. Utility function decomposition speeds up the process of critic network learning since each subcritic is estimating a simpler function [48]. Fig. 5 shows the schematic diagram of the critic network. It consists of two separate multilayer perceptron (MLP) neural networks [49], with ten neurons in the hidden layer of each one and the same input from the action network, i.e., the neurofuzzy controller. The hyperbolic tangent is used as the activation function of the hidden neurons.

V. NEUROFUZZY CONTROLLER TRAINING

A. Critic Network Training

Forced perturbation is applied initially to the plant for a period of time in order to train the critic network. During this stage, pseudorandom binary signal (PRBS) disturbances are added to the STATCOM voltage reference V_{ref} from an external source (switches S_1 and S_2 in Fig. 6 are in position 1). The PRBS disturbance applied to the system should be generated in such a way that it excites the natural frequencies of the power system. The frequency of the PRBS disturbance is therefore heuristically chosen as a combination of 0.5, 1, and 2 Hz, close to the natural frequencies of the power system, with the total PRBS signal magnitude limited to $\pm 5\%$ of the value of V_{ref} at steady state. The neurofuzzy controller tries to force the plant to follow the reference by generating the appropriate control signal for the

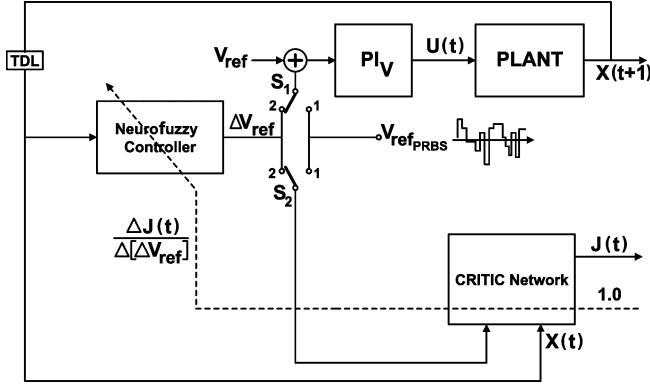

Fig. 6. Training the neurofuzzy controller.

STATCOM. The resultant deviations in the values of the power system states in (2), along with ΔV_{ref} , are now fed into the critic network, which goes through backpropagation training to update its synaptic weight matrices [37].

The critic network training starts with a low discount factor of 0.2, which is gradually increased to 0.8 as the training proceeds. This will help the weights of the critic network converge faster. Moreover, an annealing learning rate scheme is used in which the critic network training starts with a learning rate of about 0.1, and gradually decreases to a value of 0.005. This ensures that during the initial training stages, the critic network adapts itself to the plant dynamics quickly, but as the learning process continues, the network does not have drastic reactions to sudden changes in the plant dynamics. In this way, the critic network does not forget the previously learned information. This training procedure is repeated at various operating conditions until a reasonable accuracy is achieved.

B. Neurofuzzy Controller Training

In order for the neurofuzzy controller to be able to minimize the cost-to-go function over the infinite horizon of the problem, it should be trained with the following error signal:

$$e(t) = J^*(t) - J(t) \quad (11)$$

where $J^*(t)$ is the desired value for the cost-to-go function, which, in the case of dealing with deviation signals, is zero. The mean-squared error function in (12) is used as the error function for executing the backpropagation algorithm:

$$E(t) = \frac{1}{2} \times e^2(t). \quad (12)$$

A gradient descent learning algorithm is applied for adjusting the parameters of the neurofuzzy controller. The parameters that are being adjusted by the critic network are:

- 1) the consequent variables, i.e., the singleton parameters z_k ;
- 2) the centers and widths of the antecedent fuzzy sets for the input variables, i.e., m_j and σ_j .

Each parameter is updated in the negative direction of the gradient of the objective function $E(t)$. For any evolvable

parameter p :

$$p(t+1) = p(t) - \eta \frac{\Delta E(t)}{\Delta p(t)} \quad (13)$$

where η is the learning rate parameter. Since implementing and training the controller is done in discrete time, difference equations are used to indicate the change in the value of a signal from one sampling time to another. For the typical parameter/signal $v(t)$, this change is defined as

$$\Delta v(t) = v(t) - v(t-1) \quad (14)$$

where $(t-1)$ refers to one time step ago, which, in this study, is considered to be 2.0 ms before the present time t .

After conducting several simulations, it was noticed that the best performance was achieved when η is considered to be 0.02 and 0.15 for the output parameters and the antecedent fuzzy sets, respectively. However, in order to ensure the stability of the controller, a mechanism is used in this study that momentarily limits the aforementioned learning rate parameters to very small numbers if the magnitude of the training signal, i.e., the rate of change in the error function with respect to the change in parameter p , exceeds a user-defined threshold. In this way, the parameters of the controller are prevented from changing drastically due to a large training signal. The partial derivative of the objective function with respect to any parameter can be derived using the following chain rule:

$$\frac{\Delta E(t)}{\Delta p(t)} = \frac{\Delta E(t)}{\Delta J(t)} \times \frac{\Delta J(t)}{\Delta[\Delta V_{\text{ref}}(t)]} \times \frac{\Delta[\Delta V_{\text{ref}}(t)]}{\Delta p(t)}. \quad (15)$$

The first term on the right-hand side of (15) is equal to $J(t)$ and the second term can be derived by backpropagating constant 1.0 through the critic network [50]. The last term in (15) denotes the sensitivity of the controller output to any of the evolvable parameters p . The equations are provided in Appendix A.

The ACD neurofuzzy controller is trained by the cost-to-go function defined in (9) using the update formula in (13) and (15), so that its output coefficients are adjusted for optimum performance. The controller is trained online during the actual performance of the power system. Various faults and disturbances are applied to the power network, and the resultant error signal derived in (11) is used for updating the parameters of the neurofuzzy controller.

VI. SIMULATION RESULTS

A. Training Results

The fuzzy membership sets are initialized using trial and error based on the performance of the controller during different disturbances. The controller is then trained at different operating conditions when the power system is exposed to various faults and disturbances. Figs. 7 and 8 compare the membership sets for the input variables $\Delta\omega_3$ and $\Delta\omega_4$ before and after the training. The results clearly indicate that some of the sets have been drastically changed, compared to the original settings derived by a human expert.

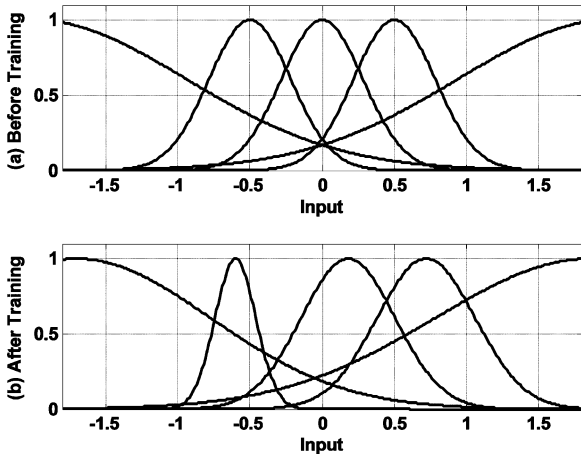

Fig. 7. Antecedent fuzzy sets for speed deviations of generator 3. (a) Before the training. (b) After the training.

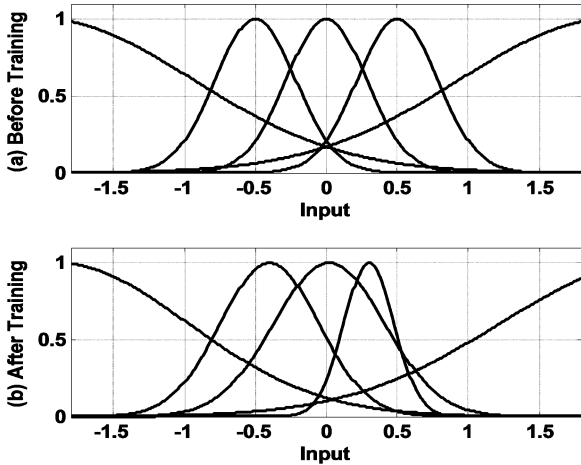

Fig. 8. Antecedent fuzzy sets for speed deviations of generator 4 (a) before and (b) after the training.

B. Testing Results

Several tests are now carried out in order to evaluate the effectiveness of the proposed neurofuzzy external controller and compare its performance (with full updating and partial updating) with the case where the STATCOM has no external controller (uncompensated system). During the faults and disturbances applied to the power system, the objective of the STATCOM external controller is to damp out the rotor speed deviations of the two generators quickly and effectively, and to achieve this with the least amount of additional reactive power injection to the power system with respect to the steady-state conditions.

1) *Case Study 1: Transmission Lines 2–5 Switched ON/OFF:* In the first test, the transmission line connecting buses 2 and 5 is disconnected and is then switched back into the power system after 3 s. Fig. 9 shows the superiority of the proposed neurofuzzy external controller in damping out the rotor speed deviations quickly. It also shows that the neurofuzzy with full update slightly improves the damping, compared to the controller with partial update. However, the improvement is more

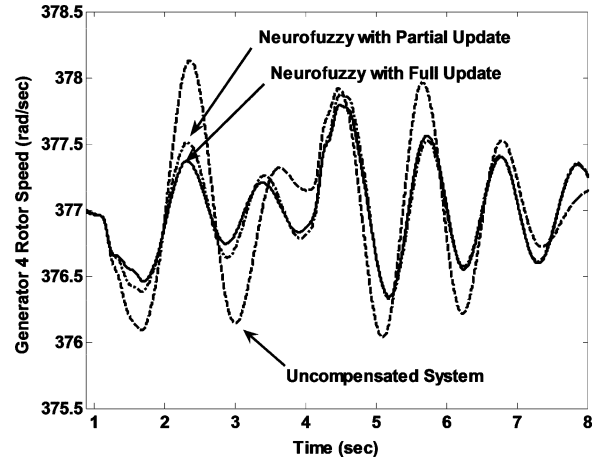

Fig. 9. Rotor-speed deviations of generator 4 during Case Study 1.

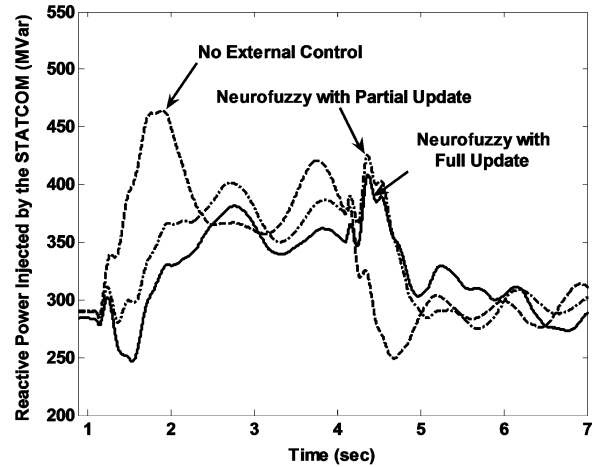

Fig. 10. Reactive power injected by the STATCOM during Case Study 1.

apparent in terms of the control effort provided by the STATCOM. Fig. 10 shows that the STATCOM equipped with a neurofuzzy controller with fully evolvable parameters reduces the peak reactive power injected by the STATCOM by 17 and 54 MVar, compared to the controller with partial update and the uncompensated system, respectively. This leads to major savings in the capital investment of the FACTS device. For more related information and an economic cost analysis, the reader is referred to [37].

2) *Case Study 2: Short-Circuit Midway Along the Transmission Lines 4–6:* A 100-ms three-phase short-circuit is now applied midway along the transmission line connecting buses 4 and 6. The line is disconnected after the fault is cleared. Fig. 11 illustrates the effectiveness of the fully evolvable neurofuzzy controller, compared to the controller with partial update, in restoring the system back to the steady-state condition. It shows that the uncompensated system is not able to damp out the oscillations effectively. Fig. 12 illustrates the active power flow through the transmission line connecting buses 7 and 8, and emphasizes the fact that the STATCOM, controlled by the fully evolvable neurofuzzy controller, damps out the power oscillations with smaller magnitude. Simulation results also

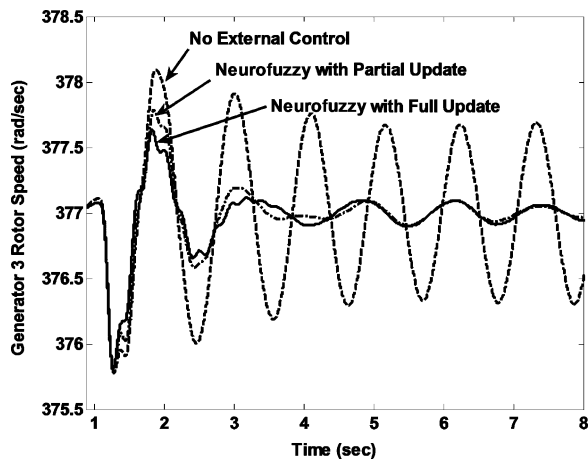

Fig. 11. Rotor-speed deviations of generator 3 during Case Study 2.

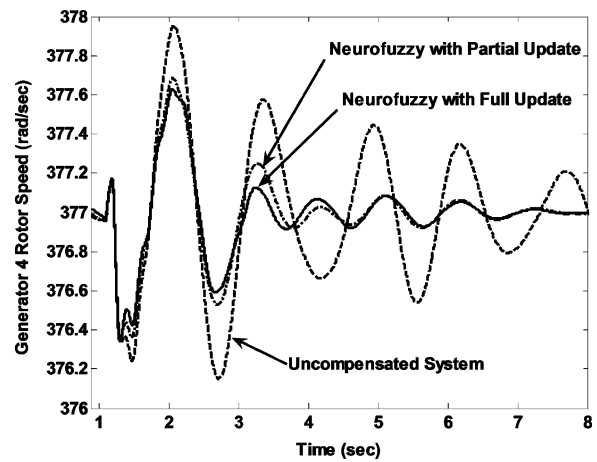

Fig. 13. Rotor-speed deviations of generator 4 during Case Study 3.

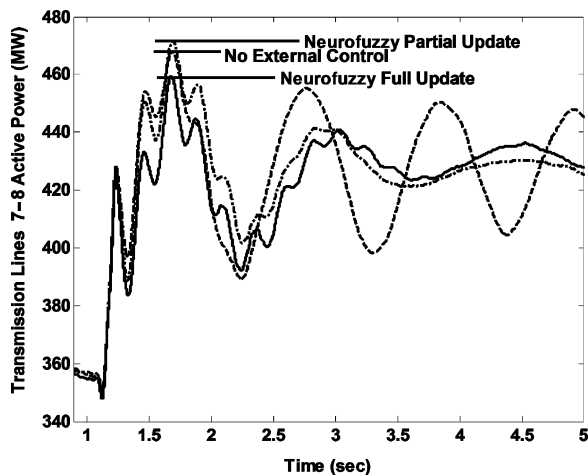

Fig. 12. Active power through the transmission lines 7 and 8 during Case Study 2.

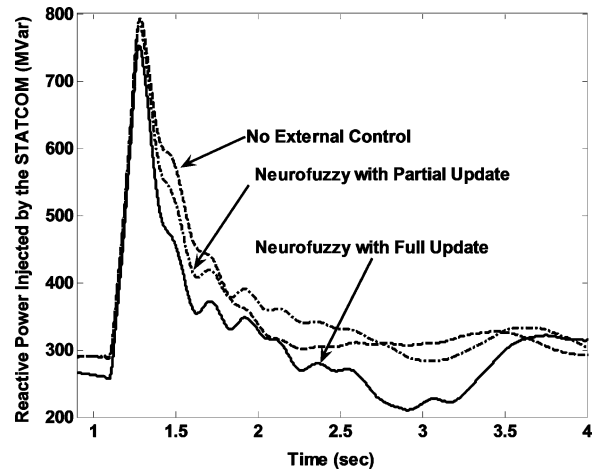

Fig. 14. Reactive power injected by the STATCOM during Case Study 3.

indicate that the neurofuzzy controller, with full update, limits the reactive power injected by the STATCOM to 462 MVar, whereas the partially updated controller and the uncompensated power system force the STATCOM to inject 474 and 468 MVar, respectively.

Although the STATCOM external control scheme proposed in this paper is effective in damping out the line active power flow and the generator speed oscillations during disturbances, it causes temporary voltage deviations at the network buses, specifically at bus 4 where the STATCOM is connected. However, during large scale disturbances, maintaining system stability and improving the power system damping is normally a high priority, and as long as the voltage fluctuations that occur for a short duration of time are within the acceptable range of [0.95, 1.05] p.u., there can be a tradeoff between the rotor speed and the line voltage.

Examples of deliberately changing the line voltage reference (or the reactive power reference) of a shunt FACTS device during transient and dynamic disturbances have been shown for a STATCOM in [45] and [46], and for a static var compensator (SVC) in [52].

3) *Case Study 3: Short-Circuit Midway Along the Transmission Lines 3 and 4:* With the transmission lines 4–6 reconnected, a 100-ms three-phase short-circuit is now applied to the middle of one of the parallel transmission lines connecting the STATCOM to generator 3. The line is disconnected as a result of the fault. Figs. 13 and 14 show the effectiveness of the proposed neurofuzzy controller with full update in damping out the rotor speed oscillations with the least amount of reactive power injection.

It should be noted that during the normal steady-state operation of the power system, the STATCOM already injects about 290 MVar in order to maintain the desired voltage profile across the power system. It is normally customary for a STATCOM to have a safety margin in terms of reactive power so that it is able to respond to different loading conditions and/or disturbances. Clearly, the amount of this safety margin is case dependent and is decided by the design engineers. The main objective of this paper is to show that an intelligently controlled STATCOM with a fully evolvable controller is able to use less reactive power from the device's safety margin in order to respond to different faults and improve the dynamic stability of the system.

TABLE III
PERFORMANCE INDEXES OF THE STATCOM NEUROFUZZY CONTROLLERS

Type of Test	No External Control	Neuro-Fuzzy with Partial Update	Neuro-Fuzzy with Full Update
Short circuit along the transmission line 2-5	1.98	2.32	2.64
Short circuit along the transmission line 3-4	0.98	1.35	2.08
Short circuit along the transmission line 7-8	1.24	1.87	2.42
Transmission line 2-5 switch on/off	0.57	0.91	1.27
Short Circuit along the Transmission line 4-6	1.26	1.52	1.82
Overall performance index	0.204	0.288	0.383
Normalized overall performance index	1.0	1.412	1.877

C. Performance Measurement

In this section, the performance of the neurofuzzy external controller with full and partial update is compared with the uncompensated power system. A performance index is defined for each case study 1–3 as in (16):

$$PI_i = \left(\sum_{j=2}^4 \left[\sqrt{\frac{1}{N} \sum_{k=1}^N \Delta\omega_{j,k}^2} \right] \right)^{-1} + k \times \Delta Q_{\text{Peak}} \quad (16)$$

where $\Delta\omega_{j,k}$ represents the k th sample of the rotor speed deviations of the j th generator, index i represents the i th case study, and ΔQ_{Peak} is the amount of increase/decrease in the maximum value of the reactive power injected by the STATCOM with respect to the uncompensated power system. Clearly, in the case of the uncompensated system, the second term in (16) is zero. A coefficient k is considered to normalize ΔQ_{Peak} . When Q is given in MVar, the coefficient k is considered to be 0.01 in this paper.

During each fault/disturbance applied to the system, 100 samples (N) are taken from each rotor speed during the first 10 s of simulation. The overall performance index of each controller is derived according to the performance indexes PI_i , obtained from various case studies, as in (17):

$$PI = \left(\sum_i \frac{1}{PI_i} \right)^{-1} \quad (17)$$

Table III summarizes the results. In the last row of the table, the overall performance indexes are normalized based on the overall performance index of the uncompensated power system. This shows that the neurofuzzy controller with fully updated parameters improves the performance of the power system by almost 88% during large-scale disturbances. Also, by updating the parameters of the antecedent fuzzy sets, the performance of the controller is improved by almost 33%.

VII. PRACTICAL CONSIDERATIONS

A. Hardware Implementation

The proposed neurofuzzy controller can be implemented on a DSP board. The authors have reported successful implementation of a fuzzy controller for a STATCOM in a multimachine power system [51]. The controller, built on a DSP board, sends the control signals to the power system that is implemented on a real-time digital simulator (RTDS).

It should be noted that the two controllers with partial updating and full updating schemes are trained only once using the data available on the system. This distinguishes them from an adaptive scheme that would undergo training all the time. Therefore, the increased computational complexities should not pose a problem due to the nature of the design.

B. Real-Time Development of Neurofuzzy Controller

Essentially, the training process of the fuzzy system is of the greatest importance and delicacy. This is due to the fact that the training stages of the critic network can be conducted offline; however, the training process of the fuzzy controller should be executed while it is controlling the plant.

In a real power system, applying disturbances for training the neurofuzzy controller might not be desirable or practical. In such cases, training data can be obtained from the normal operation of the power system, as the network is exposed to natural changes to its operating condition and/or configuration, as well as possible large-scale faults. Clearly, the critic network should be trained first. Once its weights have converged, the fuzzy controller can undergo training. In this way, the controller parameters will take a longer time to converge, but this will not cause any problems for the power system because of the following reasons.

- 1) The initial parameters of the fuzzy controller (the membership functions and the consequent parameters) are derived in a way that it stabilizes the power system. In the worst case, the fuzzy controller acts as a nonlinear gain scheduling controller that is yet more effective than a PI controller.
- 2) A critic network with its weights converged is guaranteed to provide optimal training signals for the controller [42].

It is possible in this case to define an adaptive learning rate parameter for the controller, which is increased when a change occurs in the value of its inputs and has a small value when the input values are almost constant. This prevents the controller weights/parameters from forgetting the previously learned information.

C. Installment Cost

Implementing a neurofuzzy controller like the one proposed in this paper requires a larger amount of capital investment compared to a PI controller. However, it should be noted that the installment cost of a DSP-based neurofuzzy controller for a STATCOM is negligible compared to the capital investment required for the FACTS device itself.

Moreover, the neurofuzzy controller improves the overall performance of the system by reducing the amount of reactive power injected by the STATCOM, which in turn reduces the ratings of the inverter switches and hence, its cost.

D. Online Versus Offline Training

Stability and flexibility of the connectionist systems are the most important issues that need to be addressed during the design process. The system should be stable enough to remember the previously learned information, yet flexible enough to accept new information if the operating conditions of the system fall outside the range in which it has been trained before. Failing to simultaneously achieve both these qualities will result in a suboptimal performance.

While an offline training scheme is not flexible enough to learn newly obtained information, an online training scheme might cause the controller to forget the information it has already learned, specifically if the controller stays at a different operating condition for a long time, something that happens often in power systems.

In order to solve this issue, a quasi-online training scheme is considered in this paper, where during the final operation of the controller, the error signals corresponding to all the evolvable parameters are continuously observed, and the parameters that show the worst performance (highest error) in a window of 1 s are updated using a batch-mode backpropagation algorithm. Only one parameter from each subset (fuzzy set mean, fuzzy set variance, and fuzzy output variables) is selected for update.

If the MSE, defined as in (18), is larger than a threshold value, then the parameters with the worst performance will be updated according to (19):

$$\text{MSE} = \frac{1}{N} \sum_{i=1}^N \left| \left(\frac{\Delta E}{\Delta p} \right)_i \right|^2 \quad (18)$$

$$p(t+1) = p(t) - \frac{\eta}{N} \sum_{i=1}^N \left(\frac{\Delta E}{\Delta p} \right)_i \quad (19)$$

where N is the number of data samples in a window of 1 s.

VIII. CONCLUSION

An evolvable neurofuzzy controller was designed in this paper based on the connectionist systems theory. The parameters of the controller, i.e., the antecedent fuzzy sets and the consequent (output) parameters, were updated in order to be able to provide near-optimal control over the infinite horizon of the problem. The proposed controller was designed for supervisory level control of a STATCOM in a multimachine power system. This control application was intentionally chosen since it portrays a nonlinear nonstationary system in the presence of noise and uncertainties.

Using adaptive critic designs theory, the neurofuzzy controller is able to provide nonlinear near-optimal control with no need of any mathematical model of the power system or the STATCOM. Reinforcement learning is applied for training the external controller, which makes the design methodology largely insensitive to the size of the power system.

Simulation results have been provided to indicate that the proposed neurofuzzy external controller is effective in improving the overall power system damping. The effectiveness of the controller is further improved when it undergoes a full update scheme compared to a partial update scheme. Moreover, it achieves this with smaller amounts of reactive power injected by the STATCOM as a result of the faults, which in turn could lead to a smaller STATCOM size, and therefore, savings in the cost of the FACTS device if it were to have a secondary function of providing system damping.

APPENDIX A

SENSITIVITY ANALYSIS OF THE FUZZY CONTROLLER

In this section, equations are provided for the sensitivity analysis of the fuzzy controller output with respect to different parameters of the controller. These values should be used in the update equation in (15).

A. Consequent (Output) Variables

Using (5), the derivative of the controller output with respect to the output parameters can be expressed as

$$\frac{\Delta[\Delta V_{\text{ref}}(t)]}{\Delta z_k(t)} = \frac{w_k}{\sum_n w_n} \quad (20)$$

B. Input Membership Functions

Assuming that the membership functions are defined as in (3), the sensitivity of the output to each of the parameters of the j th antecedent membership function can be expressed as

$$\frac{\Delta[\Delta V_{\text{ref}}(t)]}{\Delta \mu_j(x)} = \frac{\Delta(\sum_n w_n \times z_n / \sum_n w_n)}{\Delta \mu_j(x)} \quad (21)$$

which can be expanded as

$$\begin{aligned} \frac{\Delta[\Delta V_{\text{ref}}(t)]}{\Delta \mu_j(x)} &= \left[\sum \left(z_n \times \frac{\Delta w_n}{\Delta \mu_j(x)} \right) \times \sum w_n \right. \\ &\quad \left. - \left(\sum w_n \times z_n \right) \times \sum \frac{\Delta w_n}{\Delta \mu_j(x)} \right] / \left(\sum w_n \right)^2 \end{aligned} \quad (22)$$

and hence

$$\begin{aligned} \frac{\Delta[\Delta V_{\text{ref}}(t)]}{\Delta \mu_j(x)} &= \left[\sum \left(z_n \times \frac{\Delta w_n}{\Delta \mu_j(x)} \right) \right] / \left(\sum w_n \right) \\ &\quad - \left[\sum \frac{\Delta w_n}{\Delta \mu_j(x)} \times \Delta V_{\text{ref}}(t) \right] / \left(\sum w_n \right) \end{aligned} \quad (23)$$

which can again be simplified as

$$\frac{\Delta[\Delta V_{\text{ref}}(t)]}{\Delta \mu_j(x)} = \frac{\sum ((\Delta w_n / \Delta \mu_j(x)) \times (z_n - \Delta V_{\text{ref}}(t)))}{\sum w_n} \quad (24)$$

Obviously, if the consequence of the n th fuzzy rule does not depend on the membership set μ_j , then the sensitivity of the rule

firing strength w_n with respect to that set will be zero. Moreover, since the min function is used for fuzzy AND, the sensitivity of w_n with respect to μ_j is equal to 1 if and only if for a certain input u , $w_n = \mu_j(u)$, and is zero otherwise.

After the sensitivity of the output signal with respect to the fuzzy set μ_j is calculated, its sensitivity to each of the parameters of the set can be derived as

$$\frac{\Delta[\Delta V_{\text{ref}}(t)]}{\Delta m_j(t)} = \frac{\Delta[\Delta V_{\text{ref}}(t)]}{\Delta \mu_j(x)} \times \frac{\Delta \mu_j(x)}{\Delta m_j(t)} \quad (25)$$

which can be simplified as

$$\frac{\Delta[\Delta V_{\text{ref}}(t)]}{\Delta m_j(t)} = \frac{\Delta[\Delta V_{\text{ref}}(t)]}{\Delta \mu_j(x)} \times \frac{(x - m_j(t))}{\sigma_j^2(t)} \times \mu_j(x) \quad (26)$$

and similarly

$$\frac{\Delta[\Delta V_{\text{ref}}(t)]}{\Delta \sigma_j(t)} = \frac{\Delta[\Delta V_{\text{ref}}(t)]}{\Delta \mu_j(x)} \times \frac{(x - m_j(t))^2}{\sigma_j^3(t)} \times \mu_j(x). \quad (27)$$

REFERENCES

- [1] J. M. Mendel, *Uncertain Rule-Based Fuzzy Logic Systems*. Englewood Cliffs, NJ: Prentice-Hall, 2001.
- [2] Y. H. Song and A. T. Johns, "Application of fuzzy logic in power systems, Part 2: Comparison and integration with expert systems, neural networks and genetic algorithms," *Inst. Electr. Eng. Power Eng. J.*, vol. 12, no. 4, pp. 185–190, Aug. 1998.
- [3] Y. H. Song and A. T. Johns, "Application of fuzzy logic in power systems, Part 3: Example applications," *Inst. Electr. Eng. Power Eng. J.*, vol. 13, no. 2, pp. 97–103, Apr. 1999.
- [4] C. C. Lee, "Fuzzy logic in control systems: Fuzzy logic controller, Parts I & II," *IEEE Trans. Syst., Man, Cybern.*, vol. 20, no. 2, pp. 404–430, Mar./Apr. 1990.
- [5] A. Lotfi and A. C. Tsoi, "Importance of membership functions: A comparative study on different learning methods for fuzzy inference systems," in *Proc. IEEE Int. Conf. Fuzzy Syst.*, Orlando, FL, Jun. 1994, pp. 1791–1796.
- [6] J. S. R. Jang and C. T. Sun, "Neuro-fuzzy modeling and control," *Proc. IEEE*, vol. 83, no. 3, pp. 378–405, Mar. 1995.
- [7] C. L. Chen and C. T. Hsieh, "User friendly design method for fuzzy logic controller," *Proc. Inst. Electr. Eng.—Control Theory Appl.*, vol. 143, no. 4, pp. 358–366, Jul. 1996.
- [8] E. Hisdal, "The IF THEN ELSE statement and interval valued fuzzy sets of higher type," *Int. J. Man-Mach. Stud.*, vol. 15, pp. 385–455, 1981.
- [9] Q. Liang and J. M. Mendel, "Interval type-2 fuzzy logic systems: Theory and design," *IEEE Trans. Fuzzy Syst.*, vol. 8, no. 5, pp. 535–550, Oct. 2000.
- [10] P. P. Angelov, *Evolving Rule-Based Models: A Tool for Design of Flexible Adaptive Systems*. Heidelberg, Germany: Springer-Verlag, 2002.
- [11] P. P. Angelov and D. P. Filev, "An approach to online identification of Takagi–Sugeno fuzzy models," *IEEE Trans. Syst., Man, Cybern. B, Cybern.*, vol. 34, no. 1, pp. 484–498, Feb. 2004.
- [12] M. Figueiredo and F. Gomide, "Design of fuzzy systems using neurofuzzy networks," *IEEE Trans. Neural Netw.*, vol. 10, no. 4, pp. 815–827, Jul. 1999.
- [13] C. T. Lin and C. S. G. Lee, "Reinforcement structure/parameter learning for neural-network-based fuzzy logic control systems," *IEEE Trans. Fuzzy Syst.*, vol. 2, no. 1, pp. 46–63, Feb. 1994.
- [14] A. Lotfi and A. C. Tsoi, "Learning fuzzy inference systems using an adaptive membership function scheme," *IEEE Trans. Syst., Man, Cybern.*, vol. 26, no. 2, pp. 326–331, Apr. 1996.
- [15] H. C. Anderson, A. Lotfi, and A. C. Tsoi, "A new approach to adaptive fuzzy control: The controller output error method," *IEEE Trans. Syst., Man, Cybern. B, Cybern.*, vol. 27, no. 4, pp. 686–691, Aug. 1997.
- [16] N. Hosseinzadeh and A. Kalam, "A direct adaptive fuzzy power system stabilizer," *IEEE Trans. Energy Convers.*, vol. 14, no. 4, pp. 1564–1571, Dec. 1999.
- [17] F. J. Lin, C. H. Lin, and P. H. Shen, "Self-constructing fuzzy neural network speed controller for permanent magnet synchronous motor drive," *IEEE Trans. Fuzzy Syst.*, vol. 9, no. 5, pp. 751–759, Oct. 2001.
- [18] D. Z. Fang, Y. Xiaodong, T. S. Chung, and K. P. Wong, "Adaptive fuzzy logic SVC damping controller using the strategy of oscillation energy descent," *IEEE Trans. Power Syst.*, vol. 19, no. 3, pp. 1414–1421, Aug. 2004.
- [19] A. Rubaai, A. R. Ofoli, L. Burge, III, and M. Garuba, "Hardware implementation of an adaptive network-based fuzzy controller for dc-dc converters," *IEEE Trans. Ind. Appl.*, vol. 41, no. 6, pp. 1557–1565, Nov./Dec. 2005.
- [20] P. J. Werbos, "Tutorial on neurocontrol, control theory and related techniques: From backpropagation to brain-like intelligent systems," presented at the 12th Int. Conf. Math. Comput. Model. Sci. Comput. (ICMCM & SC), Chicago, IL, Aug. 1999.
- [21] P. J. Werbos, "A menu of designs for reinforcement learning over time," in *Neural Networks for Control*. Cambridge, MA: MIT Press, 1990, pp. 67–95.
- [22] A. Kazemi, A. Tofoghi, and B. Mahdian, "A nonlinear fuzzy PID controller for CSI-STATCOM," in *Proc. Int. Conf. Power Electron., Drives Energy Syst.*, Dec. 2006, pp. 1–7.
- [23] M. R. Zolghadri, A. Ghafari, and M. Ehsan, "Power system transient stability improvement using fuzzy controlled STATCOM," in *Proc. IEEE PowerCon.*, Oct. 2006, pp. 1–6.
- [24] S. Mohagheghi, R. G. Harley, and G. K. Venayagamoorthy, "Modified Takagi–Sugeno fuzzy logic based controllers for a static compensator in a multimachine power system," in *Proc. IEEE IAS*, Seattle, WA, Oct. 2004, pp. 2637–2642.
- [25] J. M. Ramirez, O. R. Tapia, J. C. Rosas, and J. A. Vega, "StatCom's voltage regulation by a neurocontroller," in *Proc. IEEE PES*, Jun. 2007, pp. 1–7.
- [26] S. Mohagheghi, J. W. Park, R. G. Harley, G. K. Venayagamoorthy, and M. L. Crow, "Indirect adaptive neurocontrol scheme for a static compensator connected to a power system," in *Proc. Int. Fed. Autom. Cont.*, Seoul, Korea, Sep. 2003, pp. 1188–1193.
- [27] S. Mohagheghi, Y. del Valle, G. K. Venayagamoorthy, and R. G. Harley, "A proportional-integrator type adaptive critic design based neurocontroller for a static compensator in a multimachine power system," *IEEE Trans. Ind. Electron.*, vol. 54, no. 1, pp. 86–96, Feb. 2006.
- [28] B. H. K. Chia, S. Morris, and P. K. Dash, "A feedback linearization based fuzzy-neuro controller for current source inverter-based STATCOM," in *Proc. PESC*, Dec. 2003, pp. 172–179.
- [29] L. Dong, M. L. Crow, Z. Yang, C. Shen, L. Zhang, and S. Atcitty, "A reconfigurable FACTS system for university laboratories," *IEEE Trans. Power Syst.*, vol. 19, no. 1, pp. 120–128, Feb. 2004.
- [30] P. Rao, M. L. Crow, and Z. Yang, "STATCOM control for power system voltage control applications," *IEEE Trans. Power Del.*, vol. 15, no. 4, pp. 1311–1317, Oct. 2000.
- [31] P. Garcia-Gonzalez and A. Garcia-Cerrada, "Control system for a PWM-based STATCOM," *IEEE Trans. Power Del.*, vol. 15, no. 4, pp. 1252–1257, Oct. 2000.
- [32] C. Schauder and H. Mehta, "Vector analysis and control of advanced static VAR compensator," *Proc. Inst. Electr. Eng.*, vol. 140, no. 4, pp. 299–306, Jul. 1993.
- [33] F. Liu, S. Mei, Q. Lu, Y. Ni, F. F. Wu, and A. Yokoyama, "The nonlinear internal control of STATCOM: Theory and application," *Int. J. Elect. Power Energy Syst.*, vol. 25, no. 6, pp. 421–430, 2003.
- [34] Q. Lu, F. Liu, S. Mei, and M. Goto, "Nonlinear disturbance attenuation control for STATCOM," in *Proc. IEEE PES*, Jan. 2001, vol. 3, pp. 1323–1328.
- [35] Z. Yao, P. Kesimpar, V. Donescu, N. Léchevin, and V. Rajagopalan, "Non-linear control for STATCOM based on differential algebra," in *Proc. IEEE–PESC*, May 1998, vol. 1, pp. 239–334.
- [36] P. Petitclair, S. Bacha, and J.P. Ferrieux, "Optimized linearization via feedback control law for a STATCOM," in *Proc. IEEE IAS*, New Orleans, LA, Oct. 1997, pp. 880–885.
- [37] S. Mohagheghi, G. K. Venayagamoorthy, and R. G. Harley, "Optimal neuro-fuzzy external controller for a static compensator in a 12-bus benchmark power system," *IEEE Trans. Power Del.*, vol. 22, no. 4, pp. 2548–2558, Oct. 2007.
- [38] P. Werbos, "Beyond regression: New tools for prediction and analysis in the behavioral sciences," Ph.D. dissertation, Committee Appl. Math., Harvard Univ., Cambridge, MA, 1974.
- [39] P. Werbos, *The Roots of Backpropagation: From Ordered Derivatives to Neural Networks and Political Forecasting*. New York: Wiley, 1994.

- [40] B. Widrow, N. Gupta, and S. Mitra, "Punish/reward: Learning with a critic in adaptive threshold systems," *IEEE Trans. Syst., Man, Cybern.*, vol. SMC-3, no. 5, pp. 455–465, Sep. 1973.
- [41] D. P. Bertsekas, *Dynamic Programming and Optimal Control*. Belmont, MA: Athena Scientific, 2000, pp. 269–359.
- [42] P. J. Werbos, "New directions in ACDs: Keys to intelligent control and understanding the brain," in *Proc. IEEE-INNS-ENNS*, Jul. 2000, vol. 3, pp. 61–66.
- [43] S. Jiang, U. D. Annakkage, and A. M. Gole, "A platform for validation of FACTS models," *IEEE Trans. Power Del.*, vol. 21, no. 1, pp. 484–491, Jan. 2006.
- [44] G. K. Venayagamoorthy, Y. del Valle, S. Mohagheghi, W. Qiao, S. Ray, R. G. Harley, D. M. Falcao, G. N. Taranto, and T. M. L. Assis, "Effects of a STATCOM, a SCRC and a UPFC on the dynamic behavior of a 45 bus Brazilian power system," in *Proc. IEEE PES Inaugural Conf. Expo. Africa*, Durban, South Africa, Jul. 2005, pp. 305–312.
- [45] N. G. Hingorani and L. Gyugyi, *Understanding FACTS—Concepts and Technology of Flexible AC Transmission Systems*. New Jersey: IEEE Press, 1999, pp. 135–108.
- [46] M. Mathur and R. K. Varma, *Thyristor-Based FACTS Controllers for Electrical Transmission Systems*. New York: Wiley-IEEE Press, 2002.
- [47] K. V. Patil, J. Senthil, J. Jiang, and R. M. Mathur, "Application of STATCOM for damping torsional oscillations in series compensated ac systems," *IEEE Trans. Energy Convers.*, vol. 13, no. 3, pp. 237–243, Sep. 1998.
- [48] G. L. Lendaris and J. C. Neidhoefer, "Guidance in the use of adaptive critics for control," in *Handbook of Learning and Approximate Dynamic Programming*, J. Si, A. G. Barto, W. B. Powell, and D. C. Wunsch II, Eds. Piscataway, NJ: IEEE Press, 2004, pp. 97–124.
- [49] S. S. Haykin, *Neural Networks: A Comprehensive Foundation*, 2nd ed. Englewood Cliffs, NJ: Prentice-Hall, 1998.
- [50] S. Mohagheghi. (2006, Aug.), "Adaptive critic designs based neurocontrollers for local and wide area control of a multimachine power system with a static compensator," Ph.D. dissertation, School of Elect. Comput. Eng., Georgia Inst. Technol., Atlanta, GA, 2006 [Online]. Available: <http://etd.gatech.edu/theses/available/etd-07072006-114144/>
- [51] S. Mohagheghi, G. K. Venayagamoorthy, S. Rajagopalan, and R. G. Harley, "Hardware implementation of a Mamdani based fuzzy logic controller for a static compensator in a multimachine power system," in *Proc. IEEE-IAS*, Hong Kong, Oct. 2005, vol. 2, pp. 1286–1291.
- [52] T. J. E. Miller, *Reactive Power Control in Electric Systems*. New York: Wiley, 1982.



Salman Mohagheghi (S'99–M'08) received the B.Sc. degree in power electrical engineering from the University of Tehran, Tehran, Iran, in 1998, the M.S. degree in power electrical engineering from Sharif University of Technology, Tehran, in 2001, and the Ph.D. degree in electrical engineering from Georgia Institute of Technology, Atlanta, in 2006.

He was a Postdoctoral Fellow at Georgia Institute of Technology. He is currently with ABB, Inc., U.S. Corporate Research Center, Raleigh, NC. His current

research interests include energy management systems, protection and control in power systems, and computational intelligence.



Ganesh K. Venayagamoorthy (S'91–M'97–SM'02) received the B.Eng.(Hons.) degree in electrical and electronics engineering from Abubakar Tafawa Balewa University, Bauchi, Nigeria, in 1994, and the M.Sc.Eng. and Ph.D. degrees in electrical engineering from the University of Natal, Durban, South Africa, in 1999 and 2002, respectively.

He was a Senior Lecturer with Durban Institute of Technology, Durban. In 2002, he joined Missouri University of Science and Technology (Missouri

S&T), Rolla, where he is currently an Associate Professor of electrical and computer engineering and the Director of the Real-Time Power and Intelligent Systems Laboratory. During 2007, he was a Visiting Researcher with ABB Corporate Research, Sweden. His current research interests include the development and applications of computational intelligence for real-world applications, including power systems stability and control, flexible ac transmission system (FACTS) devices, power electronics, alternative sources of energy, sensor networks, collective robotic search, signal processing, and evolvable hardware. He is the author or coauthor of two edited books, five book chapters, 60 refereed journals papers, and over 220 refereed international conference proceeding papers.

Dr. Venayagamoorthy was an Associate Editor of the IEEE TRANSACTIONS ON NEURAL NETWORKS (from 2004 to 2007) and the IEEE TRANSACTIONS ON INSTRUMENTATION AND MEASUREMENT (2007). He is a Senior Member of the South African Institute of Electrical Engineers (SAIEE), and the International Neural Network Society (INNS). He is a member of the Institution of Engineering and Technology, U.K., and the American Society for Engineering Education. He is currently the Chapter Chair of the IEEE St. Louis Computational Intelligence Society (CIS), the Chapter Chair of the Industry Applications Society (IAS), the Chair of the Working Group on Intelligent Control Systems, the Secretary of the Intelligent Systems Subcommittee, the Vice Chair of the Student Meeting Activities Subcommittee of the IEEE Power Engineering Society, and the Chair of the IEEE CIS Task Force on Power System Applications. He has organized and chaired several panels, invited and regular sessions, and tutorials at international conferences and workshops. He was the recipient of the 2007 U.S. Office of Naval Research Young Investigator Program Award, the 2004 National Science Foundation (NSF) CAREER Award, the 2006 IEEE Power Engineering Society Walter Fee Outstanding Young Engineer Award, the 2006 IEEE St. Louis Section Outstanding Section Member Award, the 2005 IEEE IAS Outstanding Young Member Award, the 2005 SAIEE Young Achievers Award, the 2004 IEEE St. Louis Section Outstanding Young Engineer Award, the 2003 INNS Young Investigator Award, the 2001 IEEE CIS Walter Karplus Summer Research Award, five prize papers from the IEEE IAS and IEEE CIS, the 2007 Missouri S&T Teaching Commendation Award, the 2006 Missouri S&T School of Engineering Teaching Excellence Award, and the 2007 and 2005 Missouri S&T Faculty Excellence Award. He is listed in the 2007 and 2008 editions of *Who's Who in America*, 2008 edition of *Who's Who in the World*, and 2008 edition of *Who's Who in Science and Engineering*.



Ronald G. Harley (M'77–SM'86–F'92) received the M.Sc.Eng. degree (*cum laude*) in electrical engineering from the University of Pretoria, Pretoria, South Africa, in 1965, and the Ph.D. degree in electrical engineering from London University, London, U.K., in 1969.

In 1971, he was appointed the Chair of the Electrical Machines and Power Systems, University of Natal, Durban, South Africa, where he was a Professor of electrical engineering for many years, and also the Department Head and the Deputy Dean of Engi-

neering. He is currently the Duke Power Company Distinguished Professor at Georgia Institute of Technology, Atlanta. His current research interests include the dynamic behavior and condition monitoring of electric machines, motor drives, power systems and their components, and controlling them by the use of power electronics and intelligent control algorithms. He has authored or coauthored more than 380 papers published in refereed journals and international conferences and three patents.

Dr. Harley is a Fellow of the British Institute of Electrical Engineers, a Fellow of the Royal Society in South Africa, and a Founder Member of the Academy of Science in South Africa, formed in 1994. During 2000 and 2001, he was one of the IEEE Industry Applications Society's six Distinguished Lecturers. He was the Vice President of Operations of the IEEE Power Electronics Society (2003–2004) and the Chair of the Atlanta Chapter of the IEEE Power Engineering Society. He is currently the Chair of the Distinguished Lecturers and Regional Speakers Program of the IEEE Industry Applications Society. He received the Cyril Veinott Award in 2005 from the Power Engineering Society for "Outstanding contributions to the field of electromechanical energy conversion." He has received prizes from journals and conferences for ten of the papers.