

16 Apr 2004, 8:00am - 9:30am

## Evaluation of Rock Characteristics for a Power Plant Site in India

A. Boominathan

*Indian Institute of Technology, Madras, Chennai, Tamil Nadu, India*

S. R. Gandhi

*Indian Institute of Technology, Madras, Chennai, Tamil Nadu, India*

J. Elango

*Indian Institute of Technology, Madras, Chennai, Tamil Nadu, India*

C. Sivathanu Pillai

*Indian Institute of Technology, Madras, Chennai, Tamil Nadu, India*

Follow this and additional works at: <https://scholarsmine.mst.edu/icchge>



Part of the [Geotechnical Engineering Commons](#)

---

### Recommended Citation

Boominathan, A.; Gandhi, S. R.; Elango, J.; and Pillai, C. Sivathanu, "Evaluation of Rock Characteristics for a Power Plant Site in India" (2004). *International Conference on Case Histories in Geotechnical Engineering*. 11.

<https://scholarsmine.mst.edu/icchge/5icchge/session06/11>



This work is licensed under a [Creative Commons Attribution-Noncommercial-No Derivative Works 4.0 License](#).

This Article - Conference proceedings is brought to you for free and open access by Scholars' Mine. It has been accepted for inclusion in International Conference on Case Histories in Geotechnical Engineering by an authorized administrator of Scholars' Mine. This work is protected by U. S. Copyright Law. Unauthorized use including reproduction for redistribution requires the permission of the copyright holder. For more information, please contact [scholarsmine@mst.edu](mailto:scholarsmine@mst.edu).



## EVALUATION OF ROCK CHARACTERISTICS FOR A POWER PLANT SITE IN INDIA

### Paper No. 6.13

**Boominathan. A**

Indian Institute of Technology Madras  
Chennai, Tamil Nadu –India-600036

**Gandhi. S. R**

Indian Institute of Technology Madras  
Chennai, Tamil Nadu –India-600036

**Elango. J**

Indian Institute of Technology Madras  
Chennai, Tamil Nadu –India-600036

**Sivathanu Pillai. C**

Indira Gandhi Centre for Atomic Research,  
Kalpakkam, Tamil Nadu – India - 603102

#### ABSTRACT

Extensive geotechnical and geophysical investigations were carried out for a power plant site situated on the east coast of southern India. It is proposed to construct the foundation on rock at a depth of 18.0 m below the ground level. The geological and geotechnical characterisation of the rock have been presented in this paper. Extensive boreholes were drilled upto 40.0 m to 60.0 m depth and a few boreholes upto 120.0 m depth from the ground level. Seismic crosshole tests were conducted at soil/rock strata upto 65.0 m depth for the determination of S-wave and P-wave velocity at different depths. Dilatometer tests were conducted in weathered and hard rock at 5.0 m interval upto a depth of 65.0 m. Field permeability tests were carried out in deep boreholes by single packer method. Various laboratory tests including UCC, Brazilian, and Point load tests were carried out on rock core samples. Modulus obtained from UCC tests are compared with the in-situ modulus obtained from Dilatometer tests. Bearing capacity and settlement analysis are carried out for the proposed raft of about 113 m x 105 m size to be supported on rock. The allowable bearing pressure is estimated based on Rock Mass Rating, RQD and strength of rock cores. The settlement analysis is carried out using modulus obtained from Dilatometer tests and from the laboratory unconfined compression tests on rock core samples. The modulus of subgrade reaction and spring constants in vertical, horizontal and rocking modes of vibration are also evaluated for the static and seismic analysis of the raft.

#### INTRODUCTION

One of the major problems in Geotechnical engineering is the risk of encountering unexpected geological conditions such as sudden variation in the rock strata, failure planes and faults in the rock etc. Failure to anticipate such conditions is generally due to an inadequate geological understanding of the site.

This paper discusses the Geotechnical and Geophysical investigations carried out at a power plant site situated in India. The proposed structures are for the construction of 500 MW power plant to be located on the east coast of southern India. The site is located at a distance of 200 m from the seacoast. Number of structures including reactor building, radiation waste building, fuel building, generator and turbine building etc., are proposed. The main building including reactor building is proposed to construct on a raft of 113 x 105 m size at about 18.0 m from the existing ground level. The expected maximum loading intensity is about 1200 kPa.

#### SOIL / ROCK EXPLORATION

Soil / rock exploration study consists of drilling of 59 boreholes and conducting a series of field and laboratory tests on soil and rock upto a depth of 120.0 meter from the existing ground level. Various field tests including Seismic crosshole tests, Dilatometer tests, Standard Penetration tests and Field permeability tests are carried out at various depths to determine engineering properties of soil / rock strata. Various laboratory tests are also performed on a large number of soil and rock core samples collected at various depths to determine their index and engineering properties.

#### SITE PROFILE

All boreholes reveal in general similar stratification but thickness of layers vary depending on the location. Ground water was encountered at 1.0 to 2.9 m below ground level.

The site consists of medium dense to dense sand of 8.0 m thickness, which is followed by firm to stiff clay of about 0.5 to 5.0 m thickness. The weathered rock occurs at a depth of about 12.0 to 15.0 m and its thickness varies from 1.0 m to 3.0 m. The hard rock is encountered at a depth of about 15.0 m to 20.0 m. The hard rock consists of Charnockite, Granite and Gneiss with garnet crystals.

The typical cross section of the site is shown in Fig. 1.

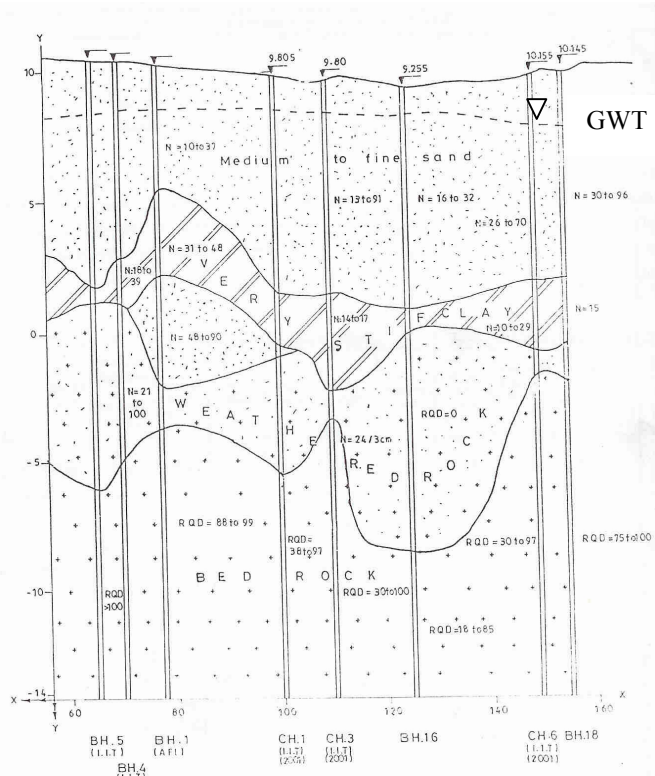

Fig. 1. Typical cross section of the site

### Stratum I

The surface layer comprises of site fill, which varies in thickness from 1.5 m upto 3.0 m. The fill is made of selected cohesionless material placed in layers not exceeding 200 mm and compacted to a relative density of 70%. This controlled fill with 70% relative density cannot liquefy due to its higher density and very rare probability of water table rising above natural ground level.

### Stratum II

Top natural stratum (at present) is loose to dense coarse sand. The particles are mainly fine to medium grained particles. The average thickness of this layer is 8.0 m. The SPT N- value increases from 23 to 91 with depth.

### Stratum III

Stratum III is a medium stiff clay layer. The thickness of this layer varies from 0.5 m to 5.0 m. The SPT-N value varies from 14 to 29. The physical properties of the clay layer can be summarized as follows: natural moisture content = 25 to 40 %, liquid limit = 42 to 150 %, plastic limit = 23 to 41 %, plasticity index = 20 to 110. The consolidation tests shows values of compression index of 0.22 to 1.13. The value of cohesion obtained from the triaxial compression tests is in the range of 54 kPa to 137 kPa.

### Stratum IV

This is moderate to highly weathered rock. The thickness of this stratum varies from 1.0 m to 3.0 m, The N-value exceeded 100 and some cases rebound of SPT hammer was observed. The core recovery and the Rock Quality Designation (RQD) are Nil in this layer.

### Stratum V

This stratum is medium to coarse-grained hard rock comprising of Charnockite, granite and gneiss with garnet crystals. This layer occurs at a depth of about 15.0 to 20.0 m. The Rock Quality Designation in this layer lies in the range of 40 to 98.

## FIELD INVESTIGATIONS

### Seismic crosshole tests

Seismic crosshole tests were carried out at an interval of 1.5 m as per ASTM D 4428 upto a depth of 65.0 m to determine P-wave and S-wave velocities at different depths. The setup for the Seismic crosshole test is given in Fig. 2.

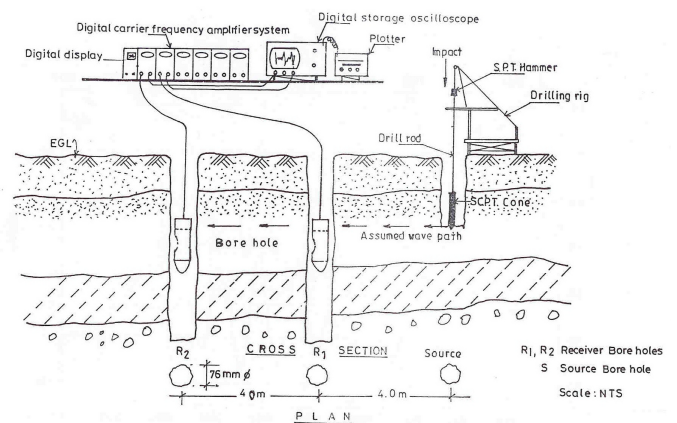

Fig. 2. Experimental setup for the seismic crosshole test

The tests were performed using two 'Nx' size receiver boreholes (R1, R2) drilled in advance upto 65.0 m depth and one source borehole (S) drilled during the time of testing. The distance between the boreholes is 4.0 m. Blows on a Standard penetration test hammer on a cone are used as a source for impulse in the source borehole. A typical wave trace obtained from the test is given in Fig. 3.

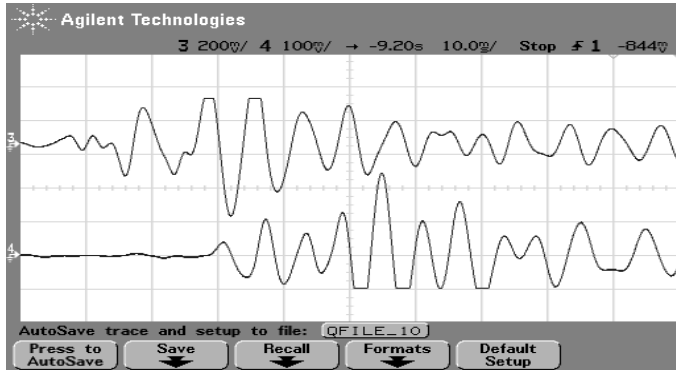

Fig. 3. Wave traces from seismic crosshole test

The wave velocities are computed from the measured travel time, knowing the distance between the boreholes. The variation of S-wave and P-wave velocities with depth is given in Fig. 4.

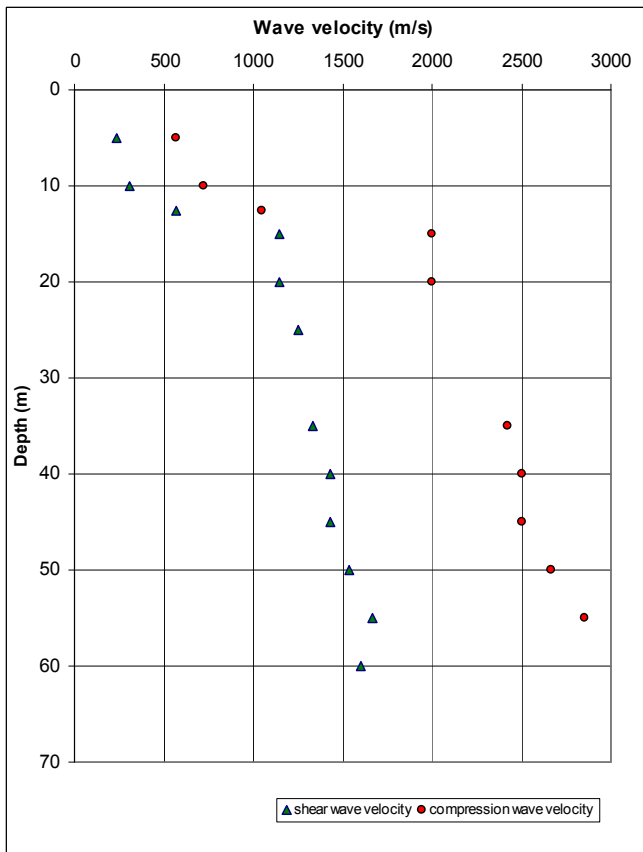

Fig. 4. Variation of P-wave and S-wave velocity with depth

The range of S-wave and P-wave velocities and Poisson's ratio obtained for various strata is listed below:

Table 1. Results of seismic crosshole tests

Sl. No.	Type of stratum	S-wave velocity, m/s	P-wave velocity, m/s	Poisson's ratio
1.	Sandy soil	167-285	470-570	0.33-0.43
2.	Clay	180-380	420-1025	0.38-0.42
3.	Weathered rock	571	1052	0.29
4.	Hard rock	1142-1667	2000-2857	0.24-0.28

Since the Seismic crosshole tests induce shear strain lower than about  $3 \times 10^{-4}\%$ , the measured shear wave velocities is used to compute the maximum shear modulus ( $G_{max}$ ), which is calculated from the following formula (Kramer, 1996)

$$G_{max} = \rho V_s^2 \quad (1)$$

Where,  $\rho$  - total density ( $kg/m^3$ ),  $V_s$  - Shear wave velocity (m/s)

The value of  $G_{max}$  obtained from crosshole tests for the weathered rock is about 1484 MPa and for the hard rock varies from 3725 to 7556 MPa.

#### Dilatometer tests

The Dilatometer tests were performed on weathered and hard rock in the interval of 5.0 m upto 65.0 m depth at selected 12 number of boreholes using the high pressure Dilatometer of 20 MPa capacity.

The Dilatometer test setup consists of High Pressure Dilatometer (HPD) with reinforced rubber membranes. It carries out an in-situ lateral loading test on the ground by means of the radial expansion of a prepared test pocket at the required depth. The central part of the instrument is covered by a tough rubber membrane. Pressure is applied to the inside of the instrument and the membrane expands, pressing against the borehole wall. The radial displacement of the inside boundary of the membrane is measured at six points equally distributed around the center of the expanding section. The radial displacement, and the pressure necessary to cause the movement, is continuously monitored by strain-gauged transducers contained within the instrument. Plotting these readings of displacement against pressure produces a loading curve for the material being tested.

The membrane calibration, arm calibration and pressure cell calibrations were done before lowering the instrument to the test pocket. The test is started by applying pressure gradually in the small intervals of 1 MPa with the time lag of 60 sec at each interval. The maximum pressure applied is about 20 MPa. The reinforced rubber membrane got punctured in the weathered rock and it was replaced with a new membrane

each time after calibration. A typical pressure vs. cavity strain curves for the weathered and hard rock obtained from the test data is given in Fig. 5 (a) and (b) respectively. The limit pressure for the hard rock strata could not be reached and hence the shear strength of rock could not be obtained from this test. But the elasticity modulus could be estimated from the following procedure:

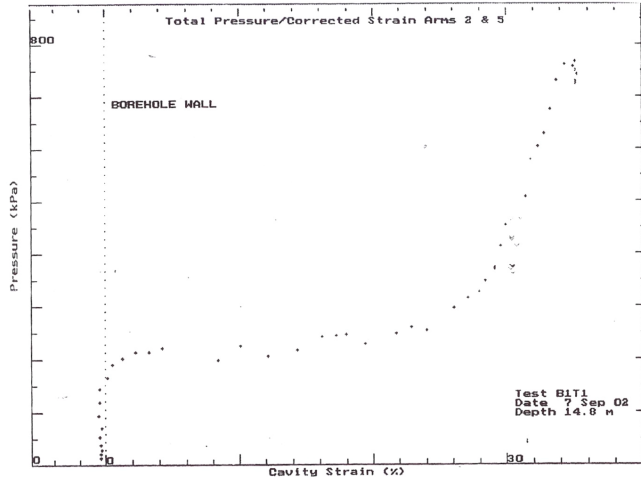

(a) Weathered rock

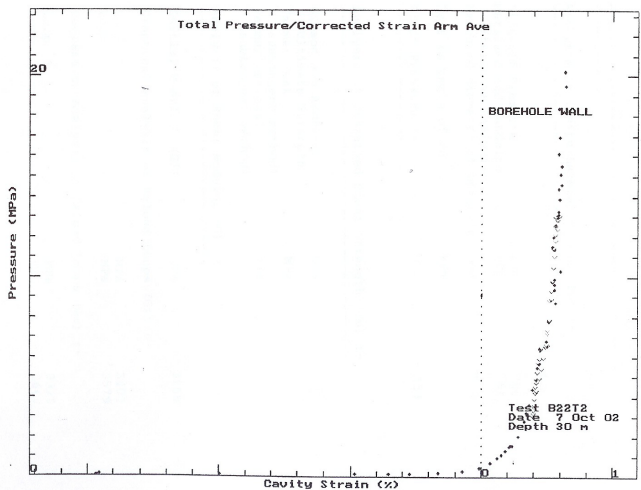

(b) Hard rock

Fig. 5 Pressure vs. Cavity strain

From the pressure vs. cavity strain curves, a tangent is drawn on the initial straight line portion of the curve. The ratio between corrected pressure and radial deformation corresponding to the extreme point on the tangent gives the modulus of subgrade reaction. The shear modulus  $G$  is obtained from the analysis data sheet, which depends on the shape of the graph. The irregular shape in the initial part of curve indicates degree of disturbance in the borehole wall, in this case the shear modulus is considered from reload loops. The criteria for selection of shear modulus value among the

reload loops is the inclination of the axis bisecting the loop (i.e., is it near to vertical / away from vertical clockwise or anticlockwise), type of strata encountered at test elevation and elevation test point. From the shear modulus the deformation modulus  $E_s$  is calculated by the following formula:

$$E_s = 2 G (1 + \nu) \quad (2)$$

The summary of the rock parameters obtained from the Dilatometer tests is given below:

Table 2. Results of Dilatometer tests

Property of rock	Range of values	
	Weathered rock	Hard rock
Shear modulus $G$	101 to 600 MPa	1481 to 7727 MPa
Modulus of deformation $E_s$	255 to 1512 MPa	3732 to 19472 MPa
Modulus of subgrade reaction	237 to 1711 $\text{kg/cm}^3$	4678 to 9649 $\text{kg/cm}^3$
Cavity strain	0.5% to 10%	

### Field permeability tests

The field permeability tests were performed by constant head method and in rock strata by single packer method. The test setup for single packer method is given in Fig. 6 (IS: 5529-Part 2).

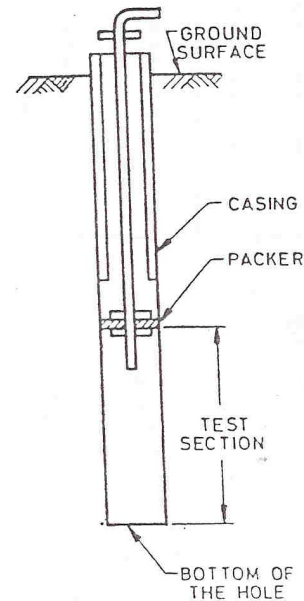

Fig. 6. Test setup for single packer method

In the single packer permeability tests, the borehole is drilled to the particular depth desired for the tests and packer is fixed at the desired level above the bottom of borehole. The test section is between the bottom of the borehole and the packer. The water is pumped under various pressures and from the

discharge of water per minute the coefficient of permeability is calculated.

The test section in this test is kept as 3.0 m for the hard rock and 1.5 m for the weathered rock. The pipe is perforated to allow water to discharge through the rock stratum and size of the pipe is 41 mm diameter. The tests were carried out by cyclic method with increase in pressure range of 3, 7, 10 kg/cm<sup>2</sup> and decreased to zero. The Lugeon values are calculated for each increment of pressure from the discharge of water per minute in the test section.

The coefficient of permeability in the top sandy layer is in the range of  $0.25 \times 10^{-3}$  to 0.2 cm/s, in the clay layer is about  $7.0 \times 10^{-5}$  cm/s, in weathered rock is about  $3.0 \times 10^{-4}$  cm/s and in hard rock varies from  $0.3 \times 10^{-7}$  to  $30.0 \times 10^{-7}$  cm/s except at few depths.

The lugeon value of weathered rock varies from 18 to 68 and for the hard rock ranges from 0.5 to 14.

## LABORATORY INVESTIGATIONS

The laboratory tests were carried out on large number of rock core samples collected from various boreholes at different depths as per relevant Indian Standard Codes. The properties of rock obtained from the laboratory tests are given below:

Table 3: Properties of Rock

Property of rock	Range of values
Density	2650 to 3400 kg/m <sup>3</sup>
Specific gravity	2.75 to 3.50
Water absorption	0 to 0.36%
Porosity	0.61 to 8.64%
Point load Index	7.5 to 26 MPa
Unconfined compressive strength	30 to 115 MPa
Young's Modulus from UCC tests	39000 to 149000 MPa
Tensile strength	8 to 19 MPa
Triaxial compressive strength	396 to 587 MPa
Flexural strength	23 to 27 MPa

## COMPARISON OF MODULUS OBTAINED FROM FIELD AND LABORATORY TESTS

The elastic modulus obtained from the seismic crosshole tests varies from 9369 to 18770 MPa. The elastic modulus values obtained from Dilatometer tests varies from 3732 to 19472 MPa. The elastic modulus values obtained from the laboratory unconfined compression tests vary from 39000 to 149000 MPa.

The deformation modulus obtained from seismic crosshole tests and Dilatometer tests shows more or less same results. The modulus values from the laboratory tests are 4 to 7 times higher than the modulus obtained from the field tests.

## GEOLOGICAL CHARACTERISATION

### Subsurface geology

The geological characteristics of the rock show the effects of chloritisation, mylonitisation etc. are almost similar in the area. The foliation/joint planes both shear planes/partings etc., which are in the form of thin films of thickness range from 0.1-0.2 m maximum.

The geological succession and their thickness are given below:

Table 4. Summary of Geological Succession

Age	Litholog	Thickness
Quaternary/ Holocene/ Pleistocene	Recent to sub-recent sediments	Brown granular zone with fine to medium grained brown sand 3.0 m
Tertiary	Fluvo marine sediments	Greyish white granular zone with silt and sand with shell fragments 4.5 m
Age	Argillaceous zone	Stiff grey plastic clay 2.5 m
Archaean	Crystalline rock	Weathered basement rock followed by hard massive garnetiferous / charnockite / migmatite Between 12.0 to 120.0 m from the GL

### Geohydrological conditions

The ground water in the area, occurs under water table condition in the upper brown granular zone and under semi-confined to confined conditions, below the thick plug of clay overlying the Archaean crystalline basement rocks

From the detailed geological logging of the drill holes, the basement rock occurs from 12 m to 16 m below the ground level. The hard basement rock belongs to the Archaean Charnockite group of rocks and Migmatite complex comprising igneous intrusive rocks and metamorphic rocks. The hard rock is homogeneous, medium to coarse grained, migmatitic at places, as such there is no major zones showing any effect of intense shearing.

### Rock Mass Rating (RMR)

Rock Mass Rating (RMR) for hard rock is calculated by using six parameters (strength of intact rock, RQD, spacing of joints, condition of joints, ground water, orientation and discontinuity) that describe the rock and rating points that are assigned to each range of values of the parameters. (Bieniawski, 1979)

Table 5. Rock Mass Rating (RMR) for hard rock

Parameter	Range of values	Rating
Strength of intact rock	50 – 100 MPa	7
RQD	50-75	13
Spacing of joints	0.6-2m	15
Condition of joints	Rough and slightly weathered	25
Ground water	Damp	10
Orientation and discontinuity	Fair	-7
RMR value for hard rock		63
Class: II (good)		

## GEOTECHNICAL CHARACTERIZATION OF HARD ROCK

The hard rock is medium to coarse-grained hard rock comprising of Charnockite, granite and gneiss with garnet crystals. This layer occurs at a depth of about 15.0 to 20.0 m. The Rock Quality Designation in the hard rock layer lies in the range of 40 to 98. The Rock Mass Rating of this hard rock is 63 and it is classified as Class II (good) rock as per Bieniawski (1979). The compression wave velocity for the rock strata varies from 2000 *m/s* to 2857 *m/s*. The value of shear wave velocity for this layer lies in the range of 1142 *m/s* to 1667 *m/s*. The unit weight lies in the range of 27 to 29 *kN/m<sup>3</sup>* and specific gravity from 2.77 to 3.49. The field permeability varies from  $0.3 \times 10^{-7}$  to  $30.0 \times 10^{-7}$  *cm/s*. The unconfined compressive strength lies in the range of 30 to 115 MPa. The triaxial compressive strength lies in the range of 396 to 587 MPa

In view of the average shear wave velocity of the rock layer is about 1475 *m/s*, site is classified as a rock site as per Uniform Building Code (Lew, 2001).

### BEARING CAPACITY

The allowable bearing capacity of the hard rock is estimated for the size of raft 113 x 105 x 4 m. The allowable bearing capacity is computed based on RQD values, RMR values and strength of rock cores:

#### (a) Based on RQD values

The allowable bearing pressure is estimated using the correlation between allowable bearing pressure and RQD proposed by Peck et al (1974). This correlation is intended only for unweathered jointed rock where joints are generally tight. If the value of the allowable bearing pressure exceeds the uniaxial compressive strength of intact rock, the allowable bearing pressure is taken as the uniaxial compressive strength. For the average value of RQD of hard rock of about 60%, the allowable bearing capacity of the rock is 6700 kPa.

#### (b) Based on RMR

The allowable bearing capacity based on RMR is estimated from the following table (IS: 12070-1987):

Table 6. Allowable bearing pressure based on RMR

Class No.	I	II	III	IV	V
Description of rock	Very good	Good	Fair	Poor	Very poor
RMR	100-81	80-61	60-41	40-21	20-0
$q_{ns}$ ( <i>t/m<sup>2</sup></i> )	600-440	440-280	280-135	135-45	45-30

The allowable bearing capacity of the hard rock for the RMR value of 63 is 2800 kPa.

#### (c) Based on strength of rock cores

The allowable bearing pressure is estimated based on the strength of rock cores. The allowable bearing pressure is given by (IS: 12070-1987):

$$q_{ba} = \sigma_c K_{sp} \quad (3)$$

where,

$\sigma_c$  = average uniaxial compressive strength

$$K_{sp} = \frac{3 + s/B}{10\sqrt{1 + 300\delta/s}}$$

*s* – spacing of joint in cm = 60 cm; *B* – footing width in cm;  $\delta$  – opening of joint in cm = 0.1 cm.

The allowable bearing pressure estimated from this method is found to be 7960 kPa.

The comparison of allowable bearing capacity obtained from the above three methods shows that the methods based on RQD values and strength of rock cores give very high allowable bearing capacity. The method based on RMR values estimates reasonably the allowable bearing capacity of the hard rock.

### SETTLEMENT ANALYSIS

The settlement of foundations on rock depends on the combined properties of the intact rock and the fractures and weathering characteristics. For many practical cases, the bearing rock can be considered to be elastic and isotropic, so the settlement occurs as the load is applied, and there is no time dependent effect. The settlement is calculated using elastic theory adopting appropriate values for the modulus and Poisson's ratio of the rock mass.

Based on modulus obtained from Dilatometer tests

The total settlement of the foundation (S) embedded in homogeneous rock is estimated from a semi-empirical formula proposed by Menard and Rousseau (Baguelin et. al, 1978):

$$S = S_d + S_e \quad (4)$$

Where,

$S_d$  - settlement due to shear or distortion deformation

$$S_d = \frac{2qB_o}{9E_m} \left( \lambda_d \frac{B}{B_o} \right)^\alpha$$

$S_e$  - Settlement due to volumetric deformation

where,

q - Maximum applied stress = 1200 kPa;  $E_m$  - Average Dilatometer modulus = 3039 MPa; Shape factors  $\lambda_d = 1.12$   $\lambda_e = 1.10$ ;  $\alpha$  - Rheological factor = 0.5;  $B_o$  - Reference width = 60 cm;

The estimated settlement of the raft by this method is 2.80 mm.

Based on modulus obtained from unconfined compressive strength of rock

Where the results of unconfined compression test on rock core samples are in sufficient numbers to be representative of the variation in strength of the rock over the depth stressed by the foundation loading, the deformation modulus ( $E_m$ ) of the rock can be obtained from the relationship (Tomlinson, 2001):

$$E_m = j M_r q_u \quad (5)$$

Where,

j - a mass factor related to the discontinuity placing in the rock mass = 0.5 (for RQD of 50 to 75%);  $M_r$  - the ratio between the deformation modulus and the unconfined compressive strength=300 (for metamorphic rocks having flat cleavage/foliation),  $q_u$  of the intact rock= 64 MPa (average value of unconfined compressive strength of the intact rock samples below the founding level);

The value of deformation modulus ( $E_m$ ) of the hard rock obtained from the above formula is 9600 MPa.

The settlement of raft foundation is estimated using the following equation (Wyllie, 1992)

$$S = \frac{C_d q B (1 - \nu^2)}{E} \quad (6)$$

Where,

q - Net foundation pressure = 1200 kPa;  $C_d$  - Shape factor = 0.95;  $\nu$  - Poisson's ratio = 0.26;

The estimated settlement of the raft foundation by this method is 11.7 mm

It can be easily noticed from the estimated values of settlement of the raft that the settlement estimated from the Dilatometer tests is about four times lower than the settlement estimated based on unconfined compressive strength of rock.

STIFFNESS CONSTANTS FOR DYNAMIC ANALYSIS

For the dynamic analysis of the raft, the stiffness constants for elastic half space model in various modes of vibration are calculated using the following formulae as per ASCE 4-98.

Table 7. Equivalent spring constant values

Motion	Equivalent spring constant	
Horizontal	$k_x = 2(1 + \nu)G\beta_x\sqrt{BL}\eta_x$	$1.61 \times 10^9$ kN/m
Vertical	$k_z = \frac{G}{1 - \nu}\beta_z\sqrt{BL}\eta_z$	$1.92 \times 10^9$ kN/m
Rocking	$k_\psi = \frac{G}{1 - \nu}\beta_\psi BL^2\eta_\psi$	$5.93 \times 10^{12}$ kN-m

G –Average shear modulus of hard rock = 5994 MPa

$\beta_x, \beta_z, \beta_\psi$  - Geometry factors as the function of L/B;  $\beta_x = 0.98$ ,  $\beta_z = 2.17$ ,  $\beta_\psi = 0.55$

$\eta_x, \eta_z, \eta_\psi$  - Embedment coefficients for spring constants

(In view of the raft is to be isolated from the adjacent ground all along the depth, the embedment factor is taken as  $\eta = 1$ ).

SUMMARY AND CONCLUSIONS

The range of values of the Geotechnical properties for various layers required for the analysis of power plant foundations have been estimated by various field and laboratory tests with reasonable accuracy. The Geotechnical and geological characterization of the hard rock has been assessed from the investigations. The RMR value of the hard rock is found to be 63 and it is classified as Class II (good rock) as per Bieniawski classification system. In view of the average shear wave velocity of rock layer is about 1475 m/s, site is classified as a rock site as per Uniform Building Code.

- Eventhough the RQD values are high in hard rock, the shear and compression wave velocities obtained from the crosshole tests indicates relatively lower value. No specific correlation could be obtained between the RQD and shear wave velocities.
- Though the limit pressure could not be reached during the Dilatometer tests, the deformation modulus for hard rock could be estimated from the Dilatometer tests.
- The deformation modulus obtained from the laboratory UCC tests carried out on rock core samples are compared with the field test and found to be 4 to 7 times higher than the field values.



- The allowable bearing capacity is estimated from different methods and the estimate based on RMR values gives a reasonable allowable bearing capacity.
- The settlement estimated using the modulus obtained from the Dilatometer tests is about four times lower than the method based on unconfined compressive strength of rock.

## REFERENCES

ASCE 4 – 98. “*Seismic analysis of safety related nuclear structures and commentary*”. American Society of Civil Engineers.

ASTM D 4428 / M-84. *Standard Test Methods for crosshole seismic testing*.

Baguelin, F., Jezequel, J. F. and Shields, D. H [1978], “*The Dilatometer and foundation engineering*”, Trans Tech publications.

Bell, F. G [1987]. “*Properties and behaviour of the ground: Geological consideration*”, in *Ground Engineer's Reference Book*, Butterworths, Part 1.1, 9.1/25.

Bieniawski, Z. T [1979]. “*The Geomechanics Classification in Rock Engineering Applications*”, A.A.Balkema, Rotterdam.

Bowles, J. E [1988] “*Foundation analysis and design*”, McGraw Hill, 4<sup>th</sup> ed., Singapore

IS:5529-1985 Part 2. Indian Standard COP for *In-situ permeability tests : Test in bedrocks*

IS:12070-1987 Indian Standard COP for *design and construction of shallow foundations in rock*.

Kramer, S. L [1996] “*Geotechnical Earthquake Engineering*”, Prentice Hall, New Jersey.

Lew [2001] “*Geotechnical Design Considerations*”, in *The Seismic Design Handbook*, (Naeim ed.), Kluwer Academic Publishing Co., 2<sup>nd</sup> ed., Chapter 3, pp. 127-182.

Peck, R. B., Hanson, W. E and Thornburn, T. H (1974) “*Foundation Engineering*”, 2<sup>nd</sup> Ed., Wiley, New York

Singh, B and Goel, R. K. [1999]. “*Rock Mass Classification*”, Elsevier, Oxford, UK

Tomlinson, M. J [2001]. “*Foundation design and construction*”, Prentice Hall, 7<sup>th</sup> Ed., New Jersey.

Wyllie, D. C [1992] “*Foundations on Rock*”, E & FN SPON, London, UK