

01 Jan 1999

Application of Composite Gyromagnetic Materials for Absorbing Radiation Produced by Microwave Oven

Marina Koledintseva
Missouri University of Science and Technology

Alexander A. Kitaytsev

V. A. Konkin

V. P. Cheparin

et. al. For a complete list of authors, see https://scholarsmine.mst.edu/ele_comeng_facwork/1457

Follow this and additional works at: https://scholarsmine.mst.edu/ele_comeng_facwork



Part of the [Electrical and Computer Engineering Commons](#)

Recommended Citation

M. Koledintseva et al., "Application of Composite Gyromagnetic Materials for Absorbing Radiation Produced by Microwave Oven," *Proceedings of the International Symposium on Electromagnetic Compatibility, 1999*, Institute of Electrical and Electronics Engineers (IEEE), Jan 1999.

The definitive version is available at <https://doi.org/10.1109/ELMAGC.1999.801350>

This Article - Conference proceedings is brought to you for free and open access by Scholars' Mine. It has been accepted for inclusion in Electrical and Computer Engineering Faculty Research & Creative Works by an authorized administrator of Scholars' Mine. This work is protected by U. S. Copyright Law. Unauthorized use including reproduction for redistribution requires the permission of the copyright holder. For more information, please contact scholarsmine@mst.edu.

APPLICATION OF COMPOSITE GYROMAGNETIC MATERIALS FOR ABSORBING RADIATION PRODUCED BY MICROWAVE OVEN

A.A.Kitaytsev, M.Y.Koledintseva, V.A.Konkin, V.P.Cheparin, A.A.Shinkov

Ferrite Lab, Moscow Power Engineering Institute (Technical University),
Russia
e-mail: koled@orc.ru

Abstract: Composite gyromagnetic radioabsorbing material (RAM) on base of polycrystalline hexagonal ferrites is elaborated for the suppression of unwanted radiation produced by microwave ovens (MWO). Results of laboratory investigation of this material application in the MWO having the magnetron source of microwave radiation are represented.

- they exhibit tremendous magnetic losses at NFMR;
- they don't need external fields of magnetization for microwave power absorption at NFMR;
- they permit to form the desired frequency characteristic of absorption by varying the composition of HF powders with different chemical structures;
- non-linear properties of such materials are not exhibited at high input microwave power levels (up to 1 kW).

INTRODUCTION

For communication systems used in everyday life, such as cellular telephones, mobile communication equipment, satellite TV, radiation of the domestic microwave ovens (MWO) presents a serious EMC problem [1]. Widely used MWO have an essential shortcoming: besides the main oscillation the magnetron has unwanted (spurious) radiation in the region of 1-18 GHz [1,2].

The problem of the unwanted radiation suppression without essential changing the MWO construction and magnetron generator variation can be solved by applying the frequency-selective radioabsorbing materials (RAM) on base of doped barium hexagonal ferrite (HF) powders [3,4].

Composite hexagonal ferrite RAM is a mixture of one or several powders of HF in a dielectric host material. In the HF the phenomenon of natural ferromagnetic resonance (NFMR) takes place. Frequency range of resonance absorption by HF particles depends upon the their chemical structure. The more the quantity of HF particles, the more is the absorption level. Absorption in the material also depends on other factors, such as the HF particles shape and size, mutual orientation of magnetic moments, scatter of inner crystallographic anisotropy magnetic field values. Bandwidth of absorption doesn't essentially depend on the chemical structure of the HF particles, it depends mainly on the distribution of anisotropy field values [5].

Nowadays the HF powders with central NFMR frequency in the range from about 2-3 to 200 GHz and absorption bandwidth up to 10 GHz could be produced [4]. Polymeric materials with low dielectric losses and possibility to operate in wide temperature range (-50⁰-+150⁰ C) should be employed as a host material for HF particles incorporation.

Materials on base of HF powders have a number of advantages for the microwave radiation suppression:

DEMANDS TO RAM APPLIED IN MWO

Level of unwanted oscillations of the MWO can be reduced by placing RAM coating on the inner walls of the magnetron output path which introduces microwave energy into the working camera. This RAM should be transparent to the main oscillation of the MWO magnetron and it should suppress spurious radiation outside the "window of transparency" at all the modes and types of waves.

RAM to be used in the MWO for the unwanted oscillations suppression should satisfy the following demands:

- low losses at the working frequency of the magnetron (less than 0.25 dB);
- high losses outside the window of transparency (more than 15 dB) in wide frequency range and all the modes in the waveguide path;
- not affecting the magnetron generating regime;
- resistance to the high levels of microwave power (up to 1 kW);
- possibility to work at temperatures more than 100 degrees Centigrade;
- no harmful and toxic chemical substances should be produced by the RAM at the MWO operation.

Besides, covering the walls of metal waveguide by RAM is expected to result in better heat dissipation of the absorbed power.

Fig.1 demonstrates the frequency characteristic of absorption in the section of rectangular waveguide (cross-section is 34x72 mm², length is 120 mm) with inner walls covered by a thin layer (about 2 mm) of the RAM on base of mixture of HF powders and high-temperature hermetic (QUALCO, USA) as a dielectric host material. On the working frequency of the MWO (2.45 GHz) losses in the

waveguide path do not exceed 0.2 dB, while in the frequency range 10-20 GHz they are more than 10 dB.

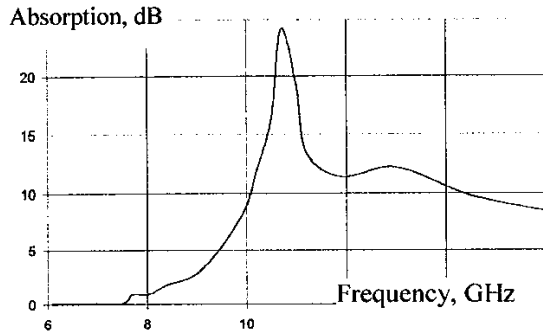

Fig. 1. Absorption characteristic of composite RAM on base of hexagonal ferrite powder and high-temperature hermetic

MWO RADIATION DIAGRAM

For laboratory measurements the standard magnetron MWO without convection and grille was employed. Measurements of the radiation diagram were carried out in the frequency range 12-13 GHz (near the 5th harmonic of the magnetron main oscillation). The working camera of the MWO was loaded by the vessel with water from urban water-supply (about 300-400 ml), placed in the center of the working camera on the rotating plate. Output power was adjusted at the maximum value – 1000 W. Measurements were carried out by means of external horn antenna with aperture 80x78 mm² and the spectrum analyzer calibrated by external high-stable microwave generator and power meter. Time of one measurement was 1 minute (several full rotations of the plate with load). The oven was placed on the rotating platform, and horn antenna was fixed so that the minimum distance from it to the MWO nearest point varied in the limits 335-490 mm. The direction normal to the MWO door was assumed as zero for angles counting clockwise (fig2).

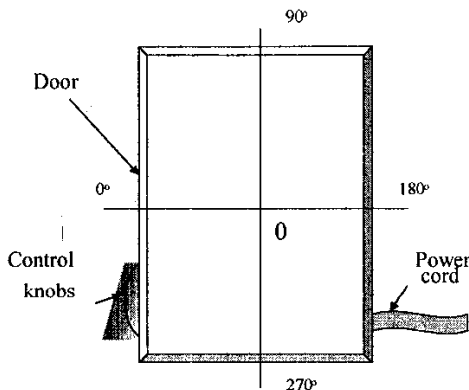

Fig.2. MWO and coordinate system

Fig.3 (dashed curve) shows the normalized radiation diagram of MWO in polar coordinates (maximum radiation power density 6.5×10^{-10} W/cm² at 1 m from the MWO center). The places with the most intensive parasitic radiation are slots between the MWO housing and the door, glass window with metal grid, slots near the knobs on the control board, ventilation perforation and place of power supply cord attachment.

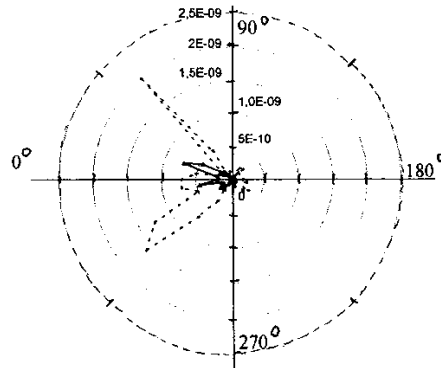

Fig.3. Radiation diagram of MWO without RAM (dashed curve) and with RAM film placed in the magnetron output waveguide (solid curve)

RADIATION DIAGRAM OF MWO WITH RAM FILMS

The composite material made of a mixture of doped hexagonal ferrites was incorporated into polymeric hermetic QUALCO resistant to 400^o C with dielectric constant $\epsilon' = 3.11$ and $\text{tg}\delta = 10^{-3}$ at $f = 12$ GHz. The coating was a single-layered film 2 mm thick. Mass concentration of HF was 50-60% (at higher concentration of ferrite the film became rather brittle). The produced absorber satisfied all the mentioned above demands. Fig.3 (solid curve) shows the radiation diagram of the MWO with RAM. Application of the material in the output waveguide of magnetron reduces radiation at 12-13 GHz (5th harmonic) minimum 12 times in all the directions. The better suppression of unwanted radiation can be achieved due to RAM positioning on the inner surfaces of MWO housing, at the places of ventilation perforation, in the construction elements of the working camera door.

CONCLUSION

Our experiments have proven possibility and efficiency of composite gyromagnetic radioabsorbing materials application for suppressing the unwanted radiation of MWO in the frequency band of communication systems. A mixture of doped barium hexagonal ferrite powders incorporated into a non-toxic polymeric base resistant to high temperatures and exhibits low losses in the “transparency” window at the frequency of the main oscillation of the MWO.

REFERENCES

- [1]. Reduction of 5th Harmonic Electromagnetic Interference from Magnetrons and Microwave Ovens. A. Harada, S. Kitakaze, T. Oguro (Hitachi, Japan). *J. Microwave Power* 1987, PP. 3-21.
- [2]. B. Despres "Microwave ovens interference potential between 1&18 GHz and associated standardisation activities in CISPR". Proc. 14th International Wroclaw Symposium and Exhibition on Electromagnetic Compatibility, Wroclaw, Poland, 23-26 June, 1998,
- [3]. A.Kitaytsev, V.Popko, V.Cheparin, A.Shinkov "Radioabsorbing composite magnetic materials and devices for ecological safety of sources of electromagnetic fields", in Proceedings of the conference "Ecology-97", Saint-Petersburg, Russia, 1997, p.58
- [4]. V.Cheparin, A.Kitaytsev, L.Eremtsova, V.Bakhteuzov Doped hexagonal ferrites for radioabsorbing materials, in Proceedings of Int. Conf. "Gyromagnetic Currentless Spin-Electronic" (ICCSE'95), Moscow, MPEI (TU), 1995, pp. 313-315
- [5]. Kitaytsev A.A., Koledintseva M.Yu., Cheparin V.P., Shinkov A.A. "Electrodynamic parameters of composite gyromagnetic material based on hexagonal ferrites", in Proceedings of URSI Symposium on Electromagnetic Theory EMT'98, Greece, Thessaloniki, V.2, p.790-793.
- [6]. Kitaytsev A.A., Koledintseva M.Yu., Shinkov A.A "Filtering of unwanted microwave radiation by means of composite gyromagnetic thick films", in Proceedings of 14th Int. Wroclaw Symp. And Exhibition on Electromagnetic Compatibility EMC'98, June 23-25, 1998, Wroclaw, Poland, p. 385-387.
- [7]. A.A. Kitaytsev, M.Yu. Koledintseva, A.A.Shinkov "Microwave Filtering of Unwanted Oscillations on base of Hexagonal Ferrite Composite Thick Films", in Proceedings of IEEE 1998 Int. Symp. On EMC, August 24-28, Denver, CO, USA, V. 1, pp. 578-582.