

01 Jan 2005

A Novel Method for Predicting Harmonic Current Injection from Non-Linear Loads using Neural Networks

Joy Mazumdar

Frank C. Lambert

Ganesh K. Venayagamoorthy
Missouri University of Science and Technology

Ronald G. Harley

Follow this and additional works at: https://scholarsmine.mst.edu/ele_comeng_facwork



Part of the [Electrical and Computer Engineering Commons](#)

Recommended Citation

J. Mazumdar et al., "A Novel Method for Predicting Harmonic Current Injection from Non-Linear Loads using Neural Networks," *Proceedings of the 31st Annual Conference of IEEE Industrial Electronics Society, 2005. IECON 2005*, Institute of Electrical and Electronics Engineers (IEEE), Jan 2005.

The definitive version is available at <https://doi.org/10.1109/IECON.2005.1569033>

This Article - Conference proceedings is brought to you for free and open access by Scholars' Mine. It has been accepted for inclusion in Electrical and Computer Engineering Faculty Research & Creative Works by an authorized administrator of Scholars' Mine. This work is protected by U. S. Copyright Law. Unauthorized use including reproduction for redistribution requires the permission of the copyright holder. For more information, please contact scholarsmine@mst.edu.

A Novel Method for Predicting Harmonic Current Injection from Non-Linear Loads Using Neural Networks

J. Mazumdar, R. Harley and F. Lambert
School of Electrical and Computer Engineering
Georgia Institute of Technology
777 Atlantic Drive
Atlanta, GA 30332, USA
rharley@ece.gatech.edu

G.K. Venayagamoorthy
Real-Time Power and Intelligent Systems Laboratory
Department of Electrical and Computer Engineering
University of Missouri-Rolla
Rolla, MO 65409, USA
gkumar@ieee.org

Abstract – Generation of harmonics and the existence of waveform pollution in power system networks is one of the major problems facing the utilities. This paper proposes a neural network solution methodology for the problem of measuring the actual amount of harmonic current injected into a power network by a nonlinear load. The determination of harmonic currents is complicated by the fact that the supply voltage waveform is distorted by other loads and is rarely a pure sinusoid. A recurrent neural network trained with the backpropagation through time (BPTT) training algorithm is used to find a way of distinguishing between the load harmonics and supply harmonics, without disconnecting the load from the network. The biggest advantage of this method is that only waveforms of voltages and currents have to be measured. This method is applicable for both single and three phase loads. This technology could be fabricated into a commercial instrument that could be installed in substations of large customer loads, or used as a hand-held clip on instrument.

I. INTRODUCTION

Power system harmonics have been known to exist on the power system for a long time. However, with the widespread proliferation of power electronic loads and other non-linear loads, significant amounts of harmonic currents are being injected into the network. Identification of harmonic sources in a power system has been a challenging task for many years. Harmonic distortions have become an important concern for all utility companies. This concern has led to the evolution of various instruments like harmonic analyzers, disturbance monitors etc. The most common approach adopted to tackle this problem was the establishment of limits on the amount of harmonic currents and voltages generated by customers and utilities. The IEEE standard 519[1, 2] and the IEC-1000-3[3] are the perfect examples. Customers are required to comply with the regulations and when any customer exceeds the limits, the only enforcement power the utility has is to disconnect the customer. This is not a desirable action. In any case before this could happen, an accurate measurement is needed.

Fig. 1 shows a simple network structure. When the non-linear load is supplied from a sinusoidal voltage source, its injected harmonic current $i_s(t)$ is referred to as *contributions from the load*. The harmonic currents cause harmonic volt drops in the supply network. Any other loads, even linear loads, connected to the point of common coupling (PCC), will have harmonic currents injected into them by the distorted PCC voltage. Such currents are referred to as *contributions from the power system*, or supply harmonics.

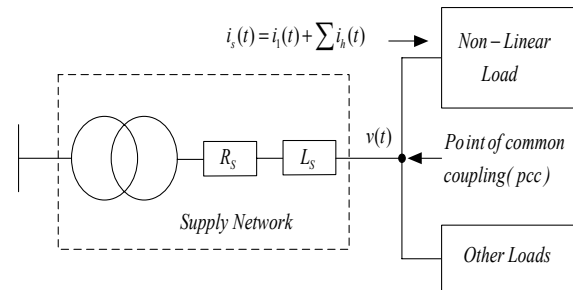

Fig. 1. Simple power system network

If several loads are connected to a PCC, it is not possible to accurately determine the amount of harmonic current injected by each load, in order to tell which load(s) is injecting the excessively high harmonic currents. If individual harmonic current injections were known, then a utility could penalize the offending consumer in some appropriate way, including say a special tariff or insist on corrective action by the consumer. Simply measuring the harmonic currents at each individual load is not sufficiently accurate since these harmonic currents may be caused by not only the non-linear load, but also by a non-sinusoidal PCC voltage.

This paper proposes a novel method based on Recurrent Neural Networks (RNNs) to determine the true harmonic current of a non-linear load. This will enable standards of harmonic pollution to be enforced by utilities and most importantly improve the power quality. A widely used approach is the harmonic power direction based method[4]. Several other methods like DFT/FFT [5], stochastic method [6] and in recent years artificial neural networks (ANNs) [7,8,9] have been proposed to measure the harmonic content in the load current, or to predict it, but most of them assume a radial feeder supplying a single load through a known feeder impedance, or multiple loads connected to a PCC which has a sinusoidal voltage and with zero impedance in the supply feeder.

II. NEURAL NETWORK ARCHITECTURE

A neural network is characterized by the ability to learn or modify its behaviour in response to the environment. The greatest advantage lies in the fact that a trained network can extract essential features from unfamiliar inputs through generalization and recognition. ANN based load identification techniques are increasingly being used in

power system applications. The Multilayer Perceptron Neural Network (MLPN) architecture is the most popular topology in use today. MLPNs have been successfully used to solve problems that require the computation of a static function, i.e. a function whose output depends only on the present input and not on any previous inputs. In the real world however, dynamic functions need to be identified. ANNs having feedback connections can implement a wide variety of dynamical systems. Recurrent neural networks (RNN) are feedback networks in which the present activation state is a function of the previous activation state as well as the present inputs. Adding feedback from the prior activation step introduces a kind of memory to the process. Fig. 2 shows the block diagram of a three layer RNN interconnected by weight matrices W and V .

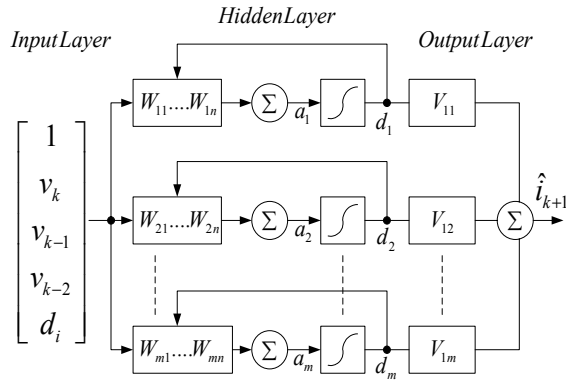

Fig. 2. RNN structure

A. Backpropagation through time training algorithm

Adding recurrent connections to a back propagation network enhances its ability to learn temporal sequences without fundamentally changing the training process. RNNs require efficient algorithms to achieve successful learning for the given task. The backpropagation through time (BPTT) algorithm is derived by unfolding the temporal operation of the network into a layered feedforward network, the topology of which grows by one layer at every time step. The BPTT approach is generally adopted to solve temporal differentiable optimization problems with continuous variables. The schematic diagram of the BPTT algorithm is shown in Fig. 3 below.

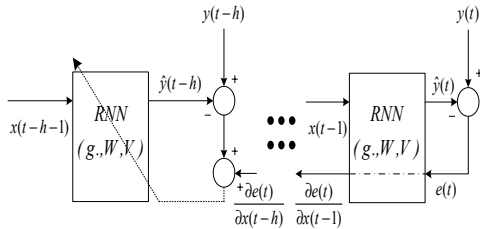

Fig. 3. Back-propagation through time algorithm schematic

The idea of unfolding in time can be applied by taking into consideration the history of the network input and state data for a fixed number of time steps. This is called the truncation depth and is generally denoted by h . Any information before

than h time steps into the past is considered irrelevant and can therefore be ignored. Similar to the standard backpropagation, for BPTT algorithm, the gradient of the sum of squared errors is used to compute the appropriate ΔW and ΔV of the network at each time instant k . The local gradient is defined as

$$\delta(l) = -\frac{\partial(e(l))}{\partial x(l-1)} \quad (1)$$

where $t-h < l < t$ and t denotes the time required to learn a temporal task starting from time t_0 to time t .

Recurrent networks will, in general, perform better than regular feedforward networks on systems with fast dynamics. They may be trained to identify or approximate any desired continuous vector mapping function $f(\cdot)$ over a specified range. The objective of the training is to modify W and V such that the RNN function $g(\cdot, W, V)$ approximates the desired function $f(\cdot)$, so that the error e between the desired function output y and the RNN output \hat{y} is minimal. Continual online training (COT) is required whenever $f(\cdot)$ is a nonlinear time varying signal and $g(\cdot, W, V)$ has to track it.

The online training cycle has two distinct paths: forward propagation and error backpropagation. Forward propagation is the passing of inputs through the RNN structure to its output. Error backpropagation is the passing of the output error through the network to the input in order to estimate the individual contribution of each weight in the network to the final output error. The weights are updated after every step so as to reduce the output error. The generalized equations are shown below [10].

B. Forward propagation

Every input in the input column vector \underline{x} is fed via the corresponding weight in the input weight matrix W to every node in the hidden layer. The activation vector \underline{a} is determined as the sum of its weighted inputs. In vector notation

$$\underline{a} = W \underline{x} \quad (2)$$

where the input column vector $\underline{x} \in R^{n+m}$, hidden layer activation column vector $\underline{a} \in R^m$ and input weight matrix $W \in R^{m \times n}$. n is the number of inputs to the neural network and m is the number of neurons in the hidden layer.

Each of the hidden node activations in \underline{a} is then passed through a sigmoid function to determine the hidden-layer decision vector \underline{d} .

$$d_i = \frac{1}{1 + e^{(-a_i)}}, \quad i \in \{1, 2, \dots, m\} \quad (3)$$

where the decision column vector $\underline{d} \in R^m$.

The decision vector \underline{d} is then fed back to the input layer (this introduces the recurrence) as well as fed to the corresponding weight in the output weight matrix V . The

RNN output \hat{y} is computed as

$$\hat{y} = (V \underline{d})^T \quad (4)$$

For a single output system output weight matrix $V \in R^{1 \times m}$ and \hat{y} is a scalar.

C. Error backpropagation

The output error e_y is calculated as

$$e_y = y - \hat{y} \quad (5)$$

For every truncation step l , the local gradient as defined in (1) is calculated as,

$$\delta(l) = V \begin{bmatrix} d_1(1-d_1) & 0 & 0 \\ 0 & \cdot & 0 \\ 0 & 0 & d_n(1-d_n) \end{bmatrix} W^* e_y(l) \quad (6)$$

where $t-h < l < t$

The local gradient is added to the error e_y one step before, forming the new error e .

$$e = e_y(l+1) + \delta(l) \quad (7)$$

This process is repeated h times until the truncation depth is reached and the final error e is obtained.

This output error is backpropagated through the RNN to determine the errors \underline{e}_d and \underline{e}_a in the decision vector \underline{d} and activation vector \underline{a} respectively, such that

$$\underline{e}_d = V^T e \quad (8)$$

The activation errors e_{a_i} are given as a product of the decision errors e_{d_i} and the derivative of the decisions d_i with respect to the activations a_i , where

$$\begin{aligned} e_{a_i} &= \left(\frac{d}{da_i} d_i \right) e_{d_i} \\ &= d_i(1-d_i) e_{d_i}, \quad i \in \{1, 2, \dots, m\} \end{aligned} \quad (9)$$

The change in input weights ΔW and output weights ΔV are calculated as

$$\begin{aligned} \Delta W &= \gamma_m \Delta W + \gamma_g \underline{e}_a \underline{x}^T \\ \Delta V &= \gamma_m \Delta V + \gamma_g \underline{e}_y \underline{d}^T \end{aligned} \quad (10)$$

where $\gamma_m, \gamma_g \in [0, 1]$ are the momentum and learning gain constants respectively. The last step in the training process is the actual updating of the weights every h steps;

$$\begin{aligned} W &= W + \Delta W \\ V &= V + \Delta V \end{aligned} \quad (11)$$

III. PROPOSED SCHEME

Fig. 4 is a one-line diagram of a three-phase supply network having a sinusoidal voltage source v_s , network impedance L_s, R_s and several loads (one of which is non-

linear) connected to a PCC. The nonlinear load injects distorted line current i_{abc} into the network. A recurrent neural network is trained to identify the non-linear characteristics of the load. This neural network is called the identification recurrent neural network (RNN1). A second neural network exists and is called the estimation recurrent neural network (RNN2). RNN2 is an exact replica of the trained RNN1. Existence of RNN2 enables the simulation action of isolating the load from the network and testing it without physically disconnecting the load from the network. The function of RNN2 can very well be carried out by RNN1, however that would disrupt the continual online training of RNN1 during the brief moments of testing.

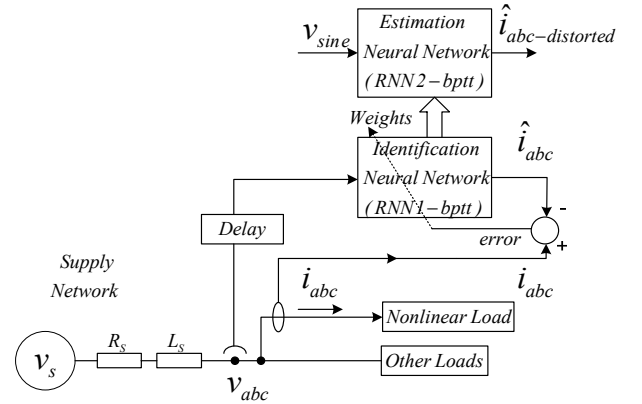

Fig. 4. Proposed scheme

A. Identification RNN

The proposed method measures the instantaneous values of the three voltages v_{abc} at the PCC, as well as the three line currents i_{abc} at the k^{th} moment in time. The voltages v_{abc} could be line-to-line or line-to-neutral measurements. The neural network is designed to predict one step ahead line current \hat{i}_{abc} as a function of the present and delayed voltage vector values $v_{abc}(k)$, $v_{abc}(k-1)$ and $v_{abc}(k-2)$. When the $k+1$ moment arrives (at the next sampling instant), the actual instantaneous values of i_{abc} are compared with the previously predicted values of \hat{i}_{abc} , and the difference (or error e) is used to train the RNN1 weights. Initially the weights have random values, but after several sampling steps, the training soon converges and the value of the error e diminishes to an acceptably small value. Proof of this is illustrated by the fact that the waveforms for i_{abc} and \hat{i}_{abc} should practically lie on top of each other. At this point the RNN1 therefore represents the admittance of the nonlinear load. This process is called *identifying* the load admittance.

Since continual online training is used, it will correctly represent the load admittance from moment to moment. At any moment in time after the RNN1 training has converged, its weights are transferred to RNN2. The training cycle of

RNN1 continues and in this way RNN2 always has updated weights available when needed.

B. Estimation RNN

RNN2 is supplied with a mathematically generated sine wave to estimate its output. The output of RNN2 called $\hat{i}_{abc-distorted}$ therefore represents the current the nonlinear load would have drawn had it been supplied by a sinusoidal voltage source. In other words, this gives the same information that could have been obtained by quickly removing the distorted PCC voltage (if this were possible) and connecting a pure sinusoidal voltage to supply the nonlinear load, except that it is not necessary to actually do this interruption. Any distortion present in the $\hat{i}_{abc-distorted}$ waveform can now be attributed to the nonlinearity of the load admittance.

C. Scaling the RNN variables

Due to the nature of the sigmoidal transfer function, the outputs of the neurons in the hidden layer are limited to values between zero and one. Thus allowing large values for the neuron input variables would cause the threshold function to be driven to saturation frequently and resulting in an inability to train. Hence, the network inputs and outputs are normally scaled between zero and one.

IV. EXPERIMENTAL RESULTS

The method of using online trained RNNs with BPTT training algorithm to identify the load admittance and testing it is briefly introduced here. In most non-linear circuits, some sort of switching power devices are used as the interface between the supply network and the actual load. The performance of the technique is demonstrated with the help of a simple test setup as shown in Fig. 5.

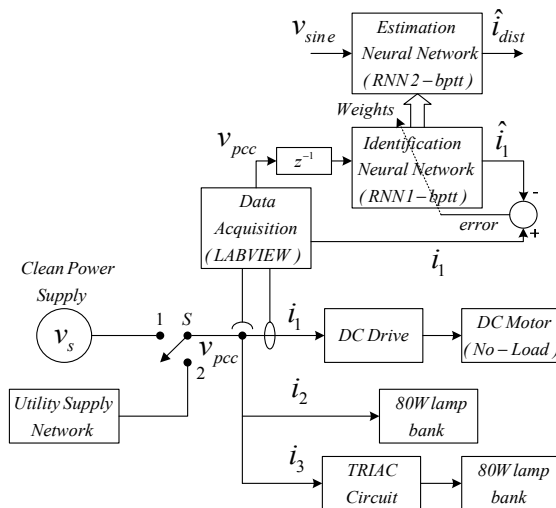

Fig. 5. Experimental setup

The proposed scheme is implemented with three single phase loads connected to a switch S defined as the point of common coupling. The voltage at the PCC is fixed at 120 Vrms, 60 Hz. When S is in position 1, the power supply comes from the utility supply network. When S is in position 2, the power supply comes from a 5 kVA AC clean power source (California Instruments 5000 iX) which provides clean sinusoidal voltage at the PCC (THD ~ 0.2%).

Load 1: Thyristor controlled dc drive supplying a dc motor on no-load.

Load 2: 80 W lamp bank connected directly to the PCC. This is a linear load.

Load 3: Electronic dimmer circuit supplying an 80 W lamp bank. This is a non-linear load and its non-linearity depends upon the setting of the firing angle. With 0° firing angle, this load becomes almost linear.

Total Harmonic Distortion (THD) is measured by a dedicated spectrum analyzer as well as by data acquisition and MATLAB software. Data acquisition for cases 1 and 2 is carried out with a system from National Instruments and LABVIEW software which stores the data on a personal computer. This data is then imported to MATLAB and using the *powergui* block of SIMULINK, the THD's are computed. These THD's are then compared with measurements taken directly by a spectrum analyzer, in order to verify that the LABVIEW and MATLAB computer code are working correctly. The sampling frequency for data acquisition is 8 kHz which ensures that harmonics up to 4 kHz can be measured theoretically. Harmonics above that are normally filtered out by filters.

With the dc drive speed reference set to 90%, and the dimmer circuit firing angle set to 30°, two different cases are evaluated with switch S either in position 1 or 2.

A. Case 1: Switch S in position 1

The circuit is supplied from the 120 V utility wall socket.

THD of voltage at PCC without any loads = 4.19%

THD of voltage at PCC with all loads connected = 4.24%

THD of current i_1 = 61.53%

THD of current i_2 = 4.25%

THD of current i_3 = 27%

B. Case 2: Switch S in position 2

The circuit is supplied from the clean power supply.

THD of voltage at PCC without any loads = 0.21%

THD of voltage at PCC with all loads connected = 0.23%

THD of current i_1 = 53.87%

THD of current i_2 = 0.28%

THD of current i_3 = 30.42%

An important result is that the current THD of the dimmer circuit is higher when it is being supplied by the clean supply

(less THD in v_{pcc}) as compared to when it is supplied by the utility (more THD in v_{pcc}). However for the dc drive, the result is the other way round.

When several loads are supplied from the PCC, with its own background THD, the individual currents are due to the combined effects of the distorted v_{pcc} and the nonlinearities of the loads. This results in some amount of phase cancellation which may reduce the overall harmonic current in the network [11] and thus benefit some of the nonlinear loads. Hence, it is essential that the method should be able to analyze every load on its merit [12].

The data obtained from case 1 for the dc drive is used to train the neural network RNN1 until the training error converges to near zero, and the output of RNN1 correctly tracks the current i_1 of the dc drive. Fig. 6 indicates how well RNN1 has converged since its output \hat{i}_1 lies on top of the actual i_1 waveform.

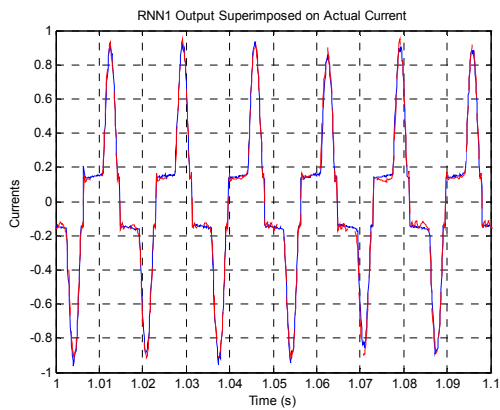

Fig. 6. i_1 and \hat{i}_1 superimposed

Once the convergence of RNN1 training is achieved, it can be concluded that RNN1 has learned the admittance of the dc drive. The weights of RNN1 are now transferred to RNN2.

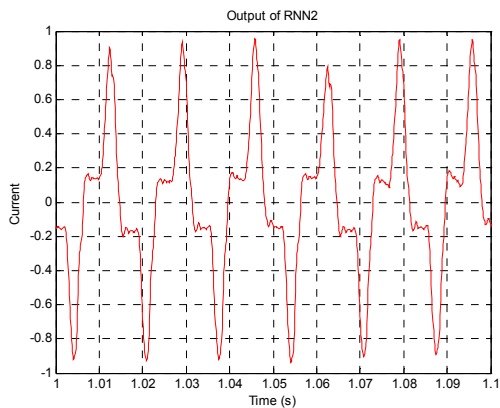

Fig. 7. \hat{i}_{1-dist} waveform when supplied by pure sine wave

The output of RNN2 is \hat{i}_{1-dist} and is shown in Fig. 7. This output is obtained by supplying RNN2 with a mathematically generated sine wave. Fig. 7 shows what Fig. 6 would have looked like if it were possible to isolate the dc drive and

supplied by a pure sine wave in reality. In other words this is the true harmonic current that would be injected by the nonlinear load into the network. Fig. 8 shows the FFT spectrum of \hat{i}_{1-dist} .

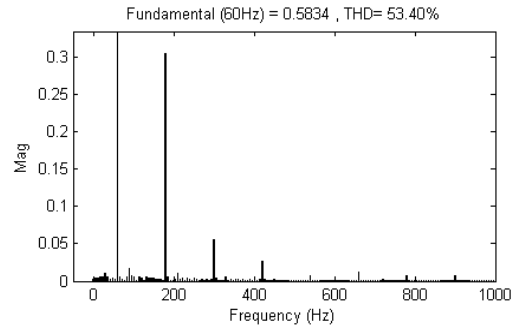

Fig. 8. FFT spectrum of \hat{i}_{1-dist} . THD=53.40%

The true current THD of \hat{i}_{1-dist} in Fig. 8 turns out to be **53.40%** instead of **61.53%** measured when the dc drive was supplied from the wall socket. This trend agrees well with the measured value of 53.87% obtained when the load was supplied by a 0.2% distorted voltage.

Similarly, the data obtained from case 1 for the dimmer circuit is used to train the neural network RNN1. Fig. 9 indicates how well RNN1 has converged since its output \hat{i}_3 lies on top of the actual i_3 waveform.

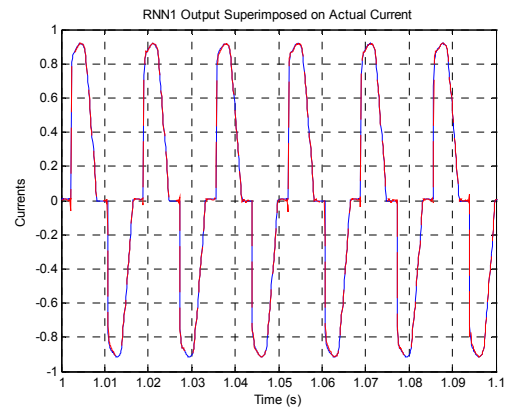

Fig. 9. i_3 and \hat{i}_3 superimposed

The weights of RNN1 are now transferred to RNN2. Fig. 10 shows the FFT spectrum of the RNN2 output \hat{i}_{3-dist} when supplied with a mathematically generated sine wave.

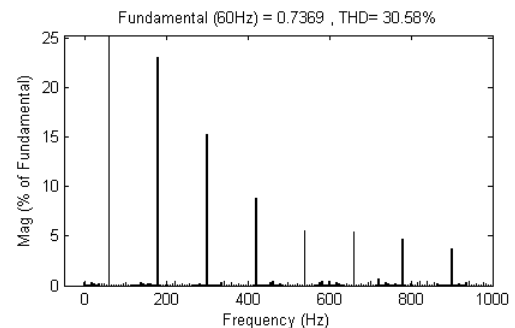

Fig. 10. FFT spectrum of \hat{i}_{3-dist} . THD=30.58%

The true current THD of \hat{i}_{3-dist} in Fig. 10 turns out to be **30.58%** instead of **27%** measured when the dimmer circuit was supplied from the wall socket. This value agrees well with the measured value of 30.42% obtained when the load was supplied by a 0.2% distorted voltage.

The salient results of the experiments performed are summarized in Table I.

TABLE I
SUMMARY OF RESULTS

Load	THD_d	THD_s	e_m
Dc drive	61.53%	53.40%	-15.22%
Dimmer	27.00%	30.58%	11.71%

A new parameter e_m known as the resultant error in measurement is introduced in Table I and can be used as an indicator of the error in the measurement if the calculation of THD was done by just measuring the input current of the non-linear load.

$$e_m = \left(\frac{THD_s - THD_d}{THD_s} \right) \% \quad (12)$$

where THD_d is i_{THD} from distorted v_{pcc} , THD_s is i_{THD} from mathematical sine wave.

The important finding from the above results show that it is erroneous to think intuitively that the current THD, when supplied from a distorted v_{pcc} should always be higher than if the v_{pcc} had no distortion.

V. CONCLUSIONS

The novel method described in this paper avoids disconnecting any loads from the system and estimates the actual harmonic current injected by each load. This information could be used to penalize the offending load. The biggest advantage of this method is that only waveforms of voltages and currents have to be measured.

Nonlinear loads exhibit customer contributed harmonics. Linear loads draw distorted currents because of a distorted v_{pcc} caused by non-linear loads. The proposed method is very useful because in an actual network, loads cannot be isolated. Therefore it is impossible to say which load is causing the pollution and which load is getting penalized.

On a practical system the neural network computations can be carried out on a DSP, together with a suitable A/D interface. Such a system could be installed permanently or be portable from one customer to another in order to simply monitor pollution levels at a particular PCC in the network.

VI. ACKNOWLEDGMENT

Financial support by the National Electric Energy Testing Research and Applications Center (NEETRAC), USA; and from the Duke Power Company, Charlotte, North Carolina, USA, for this research is greatly acknowledged.

V. REFERENCES

- [1] M. McGranaghan, "Overview of the Guide for Applying Harmonic Limits on Power Systems – IEEE 519A," in *Proceedings of the 8th International Conference on Harmonics and Quality of Power*, Vol. 1, Oct. 1998, pp. 462 - 469
- [2] IEEE Standard 519-1992, IEEE Recommended Practices and Requirements for Harmonic Control in Electric Power Systems.
- [3] Electromagnetic Compatibility (EMC)-Part 3: Limits-Section 6:Assessment of Emission Limits for Distorting Loads in MV and HV Power Systems, IEC 1000-3-6,1996.
- [4] Chun Li, Wilsun Xu, and T. Tayjasant, "A Critical Impedance Based Method for Identifying Harmonic Sources", *IEEE Transactions on Power Delivery*, Vol. 19, Issue: 2, April 2004, pp. 671 –678.
- [5] T. A. George, and D. Bones, "Harmonic power flow determination using the fast Fourier transform", *IEEE Transactions on Power Delivery*, Vol. 6 Issue: 2, April 1991, pp. 530 –535.
- [6] Y. Baghzouz, and O. T. Tan, "Probabilistic Modeling of Power System Harmonics", *IEEE Transactions on Industry Applications*, Vol. IA-23, No. 1, Jan./Feb. 1987, pp. 173-180.
- [7] H. Mori, and S. Suga, "Power system harmonics prediction with an artificial neural network", *IEEE International Symposium on Circuits and Systems*, Vol. 2, June 1991, pp. 1129 –1132.
- [8] S. Osowski, "Neural network for estimation of harmonic components in a power system", *IEE Proceedings on Generation, Transmission and Distribution*, Vol. 139, Issue 2, March 1992, pp. 129 – 135.
- [9] N. Pecharanin, H. Mitsui, and M. Sone, "Harmonic detection by using neural network", *IEEE International Conference on Neural Networks, 1995*, 27 Nov.-1 Dec. 1995, Vol.2, pp. 923 – 926.
- [10] B. Burton and R.G. Harley, "Reducing the computational demands of continually online-trained artificial neural networks for system identification and control of fast processes", *IEEE Transactions on Industry Applications*, Vol. 34, Issue: 3, May-June 1998 pp. 589 – 596.
- [11] W.M. Grady, A. Mansoor, E.F. Fuchs, P. Verde and M. Doyle, "Estimating the net harmonic currents produced by selected distributed single-phase loads: computers, televisions, and incandescent light dimmers", *IEEE Power Engineering Society Winter Meeting, 2002*, Vol. 2, 27-31 Jan. 2002, pp. 1090 – 1094.
- [12] C.R. van Niekerk, A.P.J. Rens and A.J. Hoffman, "Identification of types of distortion sources in power systems by applying neural networks", *6th IEEE AFRICON*, Vol. 2, Oct. 2002, pp. 829 – 834.