



Oct 17th, 12:00 AM

Bending and Web Crippling Interaction of Cold-formed Steel Members

Roger A. LaBoube

Missouri University of Science and Technology, laboube@mst.edu

J. A. Wallace

R. M. Schuster

Follow this and additional works at: <https://scholarsmine.mst.edu/isccss>



Part of the [Structural Engineering Commons](#)

Recommended Citation

LaBoube, Roger A.; Wallace, J. A.; and Schuster, R. M., "Bending and Web Crippling Interaction of Cold-formed Steel Members" (2002). *International Specialty Conference on Cold-Formed Steel Structures*. 1. <https://scholarsmine.mst.edu/isccss/16iccfss/16iccfss-session3/1>

This Article - Conference proceedings is brought to you for free and open access by Scholars' Mine. It has been accepted for inclusion in International Specialty Conference on Cold-Formed Steel Structures by an authorized administrator of Scholars' Mine. This work is protected by U. S. Copyright Law. Unauthorized use including reproduction for redistribution requires the permission of the copyright holder. For more information, please contact scholarsmine@mst.edu.

Bending and Web Crippling Interaction of Cold-Formed Steel Members

J. A. Wallace¹, R.M. Schuster², and R.A. LaBoube³

Abstract

The North American Specification has recently adopted a new web crippling approach for the Design of Cold-Formed Steel Structural Members (NAS, 2001). This approach is similar to what is currently in the Canadian S136 Standard (CSA, 1994). The current web crippling and bending interaction equations for single-web sections in the North American Specification (NAS 2001) are based on the previous web crippling methods that are contained in the American Iron and Steel Institute (AISI) Specification (AISI, 1996). As well, the moment component of the interaction equations was based on the previous reduced web strength method instead of the stress gradient approach that is now contained in the North American Specification (NAS, 2001).

Using the available data found in the literature, regression analyses were carried out using the new web crippling equations and the stress gradient method to substantiate the current web crippling and bending interaction equations in the North American Specification (NAS, 2001). Based on the results of this investigation, new web crippling and bending interaction equations have been developed.

1.0 Introduction

With the recent adoption of the new web crippling design approach, the web crippling and bending interaction equations contained in the North American Specification (NAS, 2001) need to be re-evaluated. The Specification contains interaction equations for single web geometry, I-beam geometry, and two nested Z-shapes.

Changes in the moment strength calculation (effective web method) have been introduced since the interaction equations were initially developed (Hettrikul and Yu, 1987) and hence, may also influence the combined web crippling and bending evaluation. Because of the changes in the web crippling and the bending strength calculations, the validity of the interaction equations must be investigated.

¹ Graduate student, Department of Civil Engineering, University of Waterloo, Waterloo, Ontario, Canada.

² Professor of Structural Engineering, Department of Civil Engineering, University of Waterloo, Waterloo, Ontario, Canada.

³ Professor of Civil Engineering, University of Missouri-Rolla, Rolla, Missouri, USA

2.0 Scope of Study

The scope of this project was to review the available data and to determine the validity of the present interaction equations in the North American Specification (NAS, 2001) for the different geometric section types. The current interaction equations were developed using the appropriate available interaction web crippling data found in the literature for single-web sections, built-up sections and nested Z-sections. Multi-web deck sections were not considered in this study. Based on the results of this study, new web crippling and bending interaction equations are proposed for adoption by the North American Specifications (NAS, 2001).

3.0 Literature Review

3.1 Web Crippling Only

Four different load categories for web crippling are addressed by the North American Specification (NAS, 2001). These categories, illustrated in Figure 1, are: Interior-One-Flange (IOF) loading, Interior-Two-Flange (ITF) loading, End-One-Flange (EOF) loading, and End-Two-Flange (ETF) loading. In the case of IOF loading there is generally an interaction of web crippling and bending possible. Web crippling and bending interaction need not be considered in the North American Specification (NAS, 2001) if the moment ratio, M/M_n , is ≤ 0.3 for single web members and 0.4 for built-up I-sections.

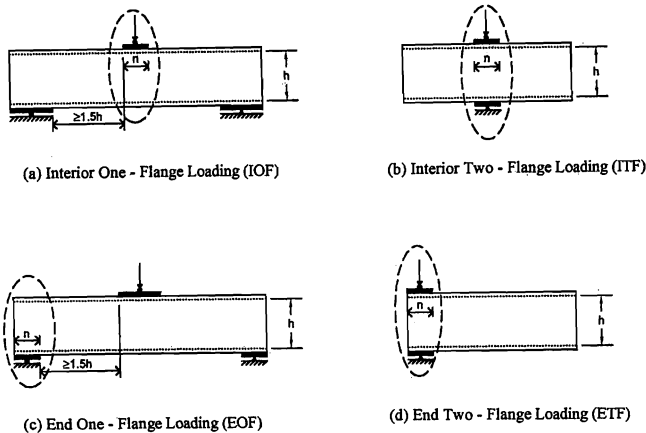

Figure 1: Load Categories for Web Crippling

The nominal web crippling strength of unreinforced webs is determined by the following equation:

$$P_n = Ct^2F_y \sin(\theta) \left\{ 1 - C_R \sqrt{\frac{R}{t}} \right\} \left\{ 1 + C_N \sqrt{\frac{N}{t}} \right\} \left\{ 1 - C_h \sqrt{\frac{h}{t}} \right\} \quad \text{Eq. C3.4.1-1 (NAS, 2001)}$$

The web crippling coefficients C , C_R , C_N and C_h are summarized by Tables C3.4.1-1 to C3.4.1-4, which were taken from the North American Specification (NAS, 2001).

**TABLE C3.4.1-1
BUILT-UP SECTIONS**

Support and Flange Conditions		Load Cases		C	C _R	C _N	C _h	Ω _w	φ _w	Limits
FASTENED TO SUPPORT	Stiffened or Partially Stiffened Flanges	One - Flange Loading or Reaction	End	10	0.14	0.28	0.001	2.00	0.75	R/t ≤ 5
			Interior	20	0.15	0.05	0.003	1.65	0.90	R/t ≤ 5
UNFASTENED	Stiffened or Partially Stiffened Flanges	One - Flange Loading or Reaction	End	10	0.14	0.28	0.001	2.00	0.75	R/t ≤ 5
			Interior	20.5	0.17	0.11	0.001	1.75	0.85	R/t ≤ 3
		Two - Flange Loading or Reaction	End	15.5	0.09	0.08	0.04	2.00	0.75	R/t ≤ 3
			Interior	36	0.14	0.08	0.04	2.00	0.75	
	Unstiffened Flanges	One - Flange Loading or Reaction	End	10	0.14	0.28	0.001	2.00	0.75	R/t ≤ 5
			Interior	20.5	0.17	0.11	0.001	1.75	0.85	R/t ≤ 3

Notes: (1) This Table applies to I-beams made from two channels connected back to back.
See Section C3.4 of Commentary for explanation.

(2) The above coefficients apply when $h/t \leq 200$, $N/t \leq 210$, $N/h \leq 1.0$ and $\theta = 90^\circ$.

**TABLE C3.4.1-2
SINGLE WEB CHANNEL AND C-SECTIONS**

Support and Flange Conditions		Load Cases		C	C _R	C _N	C _h	Ω _w	φ _w	Limits
FASTENED TO SUPPORT	Stiffened or Partially Stiffened Flanges	One - Flange Loading or Reaction	End	4	0.14	0.35	0.02	1.75	0.85	R/t ≤ 9
			Interior	13	0.23	0.14	0.01	1.65	0.90	R/t ≤ 5
		Two - Flange Loading or Reaction	End	7.5	0.08	0.12	0.048	1.75	0.85	R/t ≤ 12
			Interior	20	0.10	0.08	0.031	1.75	0.85	R/t ≤ 12
UNFASTENED	Stiffened or Partially Stiffened Flanges	One - Flange Loading or Reaction	End	4	0.14	0.35	0.02	1.85	0.80	R/t ≤ 5
			Interior	13	0.23	0.14	0.01	1.65	0.90	
		Two - Flange Loading or Reaction	End	13	0.32	0.05	0.04	1.65	0.90	R/t ≤ 3
			Interior	24	0.52	0.15	0.001	1.90	0.80	
	Unstiffened Flanges	One - Flange Loading or Reaction	End	4	0.40	0.60	0.03	1.80	0.85	R/t ≤ 2
			Interior	13	0.32	0.10	0.01	1.80	0.85	R/t ≤ 1
Two - Flange Loading or Reaction		End	2	0.11	0.37	0.01	2.00	0.75	R/t ≤ 1	
		Interior	13	0.47	0.25	0.04	1.90	0.80		

Notes: The above coefficients apply when $h/t \leq 200$, $N/t \leq 210$, $N/h \leq 2.0$ and $\theta = 90^\circ$.

For interior two-flange loading or reaction of members having flanges fastened to the support, the distance from the edge of bearing to the end of the member shall be extended at least 2.5h. For the unfastened case, the distance from the edge of bearing to the end of the member shall be extended at least 1.5h.

**TABLE C3.4.1-3
SINGLE WEB Z-SECTIONS**

Support and Flange Conditions		Load Cases		C	C _R	C _N	C _h	Ω _w	φ _w	Limits
FASTENED TO SUPPORT	Stiffened or Partially Stiffened Flanges	One - Flange Loading or Reaction	End	4	0.14	0.35	0.02	1.75	0.85	R/t ≤ 9
			Interior	13	0.23	0.14	0.01	1.65	0.90	R/t ≤ 5
		Two - Flange Loading or Reaction	End	9	0.05	0.16	0.052	1.75	0.85	R/t ≤ 12
			Interior	24	0.07	0.07	0.04	1.85	0.80	R/t ≤ 12
UNFASTENED	Stiffened or Partially Stiffened Flanges	One - Flange Loading or Reaction	End	5	0.09	0.02	0.001	1.80	0.85	R/t ≤ 5
			Interior	13	0.23	0.14	0.01	1.65	0.90	
		Two - Flange Loading or Reaction	End	13	0.32	0.05	0.04	1.65	0.90	R/t ≤ 3
			Interior	24	0.52	0.15	0.001	1.90	0.80	
	Unstiffened Flanges	One - Flange Loading or Reaction	End	4	0.40	0.60	0.03	1.80	0.85	R/t ≤ 2
			Interior	13	0.32	0.10	0.01	1.80	0.85	R/t ≤ 1
		Two - Flange Loading or Reaction	End	2	0.11	0.37	0.01	2.00	0.75	R/t ≤ 1
			Interior	13	0.47	0.25	0.04	1.90	0.80	

Notes: The above coefficients apply when $h/t \leq 200$, $N/t \leq 210$, $N/h \leq 2.0$ and $\theta = 90^\circ$.

For interior two-flange loading or reaction of members having flanges fastened to the support, the distance from the edge of bearing to the end of the member shall be extended at least $2.5h$. For the unfastened case, the distance from the edge of bearing to the end of the member shall be extended at least $1.5h$.

**TABLE C3.4.1-4
SINGLE HAT SECTIONS**

Support Conditions		Load Cases		C	C _R	C _N	C _h	Ω _w	φ _w	Limits
FASTENED TO SUPPORT	One - Flange Loading or Reaction	End	End	4	0.25	0.68	0.04	2.00	0.75	R/t ≤ 4
			Interior	17	0.13	0.13	0.04	1.90	0.80	R/t ≤ 10
		Two - Flange Loading or Reaction	End	9	0.10	0.07	0.03	1.75	0.85	R/t ≤ 10
			Interior	10	0.14	0.22	0.02	1.80	0.85	
UNFASTENED	One - Flange Loading or Reaction	End	4	0.25	0.68	0.04	2.00	0.75	R/t ≤ 4	
		Interior	17	0.13	0.13	0.04	1.70	0.90	R/t ≤ 4	

Note: The above coefficients apply when $h/t \leq 200$, $N/t \leq 200$, $N/h \leq 2$ and $\theta = 90^\circ$.

3.2 Bending Only

The nominal moment strength, M_{nxo} , of a cold-formed steel member is determined using the following expression:

$$M_{nxo} = S_e F_y$$

Eq. C3.1.1-1 (NAS, 2001)

3.3 Combined Web Crippling and Bending

The interaction of web crippling and bending is evaluated by Eqs. 1, 2 and 3. These nominal equations serve as the basis for the design equations contained in the North American Specification (NAS, 2001).

For shapes having single unreinforced webs

$$1.07\left(\frac{P_t}{P_n}\right) + \left(\frac{M_t}{M_n}\right) \leq 1.42 \quad \text{Eq. 1}$$

For I-sections such as two C-sections back-to-back

$$0.82\left(\frac{P_t}{P_n}\right) + \left(\frac{M_t}{M_n}\right) \leq 1.32 \quad \text{Eq. 2}$$

For two nested Z-shapes

$$0.85\left(\frac{P_t}{P_n}\right) + \left(\frac{M_t}{M_n}\right) \leq 1.65 \quad \text{Eq. 3}$$

4.0 Review of Data

The focus was on the following three geometric shapes:

- (1) Shapes having single unreinforced webs
- (2) Built-Up Sections such as I-sections
- (3) Two nested Z-shapes

Geometric properties including dimensional properties and material properties such as yield point are not included in this paper. The reader is referred to (Wallace et al., 2002) and (Hetrakul and Yu, 1978) for this data.

4.1 Review and Development of Interaction Equations

The accuracy of Equations 1, 2, and 3 was determined by using the ratios of the following relationships:

$$[A/1.42]; \text{ where } \mathbf{A} = 1.07\left(\frac{P_t}{P_n}\right) + \left(\frac{M_t}{M_n}\right) \quad \text{Eq. 4}$$

$$[B/1.32]; \text{ where } \mathbf{B} = 0.82\left(\frac{P_t}{P_n}\right) + \left(\frac{M_t}{M_n}\right) \quad \text{Eq. 5}$$

$$[C/1.65]; \text{ where } C = 0.85 \left(\frac{P_t}{P_n} \right) + \left(\frac{M_t}{M_n} \right) \quad \text{Eq. 6}$$

4.2 Proposed Interaction Equations:

Based on a review of the test data, the following interaction equations were developed:

(1) For shapes having single unreinforced webs; C-sections

Data - (Hetrakul and Yu, 1978; Ratliff, 1975; Young and Hancock, 2000)

$$0.89 \left(\frac{P_t}{P_n} \right) + \left(\frac{M_t}{M_n} \right) \leq 1.32 \quad \text{Eq. 7}$$

For C-sections and hat sections;

Data - (Hetrakul and Yu, 1978; Ratliff, 1975; Young and Hancock, 2000; Cornell, 1953)

$$0.91 \left(\frac{P_t}{P_n} \right) + \left(\frac{M_t}{M_n} \right) \leq 1.33 \quad \text{Eq. 8}$$

(2) For I-sections such as two C-sections back-to-back;

Data - (Hetrakul and Yu, 1978)

$$0.88 \left(\frac{P_t}{P_n} \right) + \left(\frac{M_t}{M_n} \right) \leq 1.46 \quad \text{Eq. 9}$$

The data from (Hetrakul and Yu, 1978) was based on double web I-sections. Using the data from (Hetrakul and Yu, 1978 and Winter and Pian, 1946)

$$0.64 \left(\frac{P_t}{P_n} \right) + \left(\frac{M_t}{M_n} \right) \leq 1.29 \quad \text{Eq. 10}$$

The (Winter and Pian 1946) data was based on single and double web I-sections.

(3) For two nested Z-shapes

Data - (LaBoube et al., 1994)

$$0.86 \left(\frac{P_t}{P_n} \right) + \left(\frac{M_t}{M_n} \right) \leq 1.65 \quad \text{Eq. 11}$$

A graphical representation of the above equations is included in the Appendix. The accuracy of Equations 7, 9 and 11 was determined by the following ratios:

$$[A'/1.32]; \text{ where } A' = 0.89 \left(\frac{P_t}{P_n} \right) + \left(\frac{M_t}{M_n} \right) \quad \text{Eq. 12}$$

$$[B'/1.46]; \text{ where } B' = 0.88 \left(\frac{P_t}{P_n} \right) + \left(\frac{M_t}{M_n} \right) \quad \text{Eq. 13}$$

$$[C'/1.65]; \text{ where } C' = 0.86 \left(\frac{P_t}{P_n} \right) + \left(\frac{M_t}{M_n} \right) \quad \text{Eq. 14}$$

The statistical accuracy of equations 8 and 10 was also determined by using ratios similar to Equations 12 and 13.

5.0 Calibrations

Resistance factors, ϕ , are used with the load and resistance factor design (LRFD) method in the USA and Mexico and with the limit states design (LSD) method in Canada (NAS, 2001). The resistance factors were determined in conformance with each country's respective load factors and dead to live load ratios to provide a target reliability index, β , value of 2.5 for the USA and Mexico and 3.0 for Canada (NAS, 2001).

A satisfactory design can be obtained by equating the factored resistance to the factored loads, as follows:

$$\phi R_n = c(\alpha_D D_n + \alpha_L L_n) \quad \text{Eq. 15}$$

Where R_n is the nominal resistance and α_D and α_L are the dead and live load factors, respectively, such that the load combinations are [1.2D + 1.6L] for the USA and Mexico and [1.25D + 1.5L] for Canada (NAS 2001). As well, the dead to live load ratios, D/L, are 1/5 for the USA and Mexico and 1/3 for Canada.

Considering Equation 15, it can be shown that the resistance factors, ϕ , can be determined as follows.

For USA and Mexico

$$\phi = \frac{1.521(P_m M_m F_m)}{e^{\beta \sqrt{V_R^2 + V_Q^2}}} \quad \text{Eq. 16}$$

For Canada

$$\phi = \frac{1.420(P_m M_m F_m)}{e^{\beta \sqrt{V_R^2 + V_Q^2}}} \quad \text{Eq. 17}$$

Where:

$$V_R = \sqrt{V_P^2 + V_M^2 + V_F^2} \quad \text{Eq. 18}$$

$$V_Q = \frac{\sqrt{(D_m V_D)^2 + (L_m V_L)^2}}{D_m + L_m} \quad \text{Eq. 19}$$

The values of $M_m = 1.10$, $V_M = 0.08$, $F_m = 1.00$, and $V_F = 0.05$ were taken from Table F1 – [Statistical Data for the Determination of Resistance Factor] (NAS, 2001). By knowing the resistance factor, ϕ , the corresponding factor of safety, Ω , can be computed as follows:

$$\text{For the USA and Mexico} \quad \Omega = \frac{1.2 \frac{D}{L} + 1.6}{\phi(\frac{D}{L} + 1)} = 1.533/\phi \quad \text{Eq. 20}$$

Summarized in Tables 1 to 3 are the statistical results, the corresponding factors of safety, Ω , and resistance factors, ϕ , calculated for the given test data.

6.0 Discussion of Results

The bending moment resistance values and web crippling resistance values have not been included in this paper. The reader is referred to (Wallace et al., 2002) for this information. Diagrams showing the interaction equations plotted with the data are shown in Figures A1 through A5 of Appendix A. The statistical data for the interaction equations are summarized in Tables 1 to 3. More specifically, shown in Table 1 are the results of single-unreinforced web sections, in Table 2 the results of I-sections such as two channel C-sections back to back and in Table 3 the results of nested Z-sections.

Table 1 - Shapes having Single-Unreinforced Webs

Equation	Data Source	Mean	COV	USA & Mexico		Canada ϕ
				Ω	ϕ	
Eq. 1 (Current)	Hetrakul (1978) Ratliff (1975) Young (2000)	1.025	0.097	1.69	0.907	0.782
Eq. 1 (Current)	Hetrakul (1978) Ratliff (1975) Young (2000) Cornell (1953)	1.021	0.097	1.70	0.903	0.779
Eq. 7 (Proposed)	Hetrakul (1978) Ratliff (1975) Young (2000)	1.004	0.101	1.73	0.885	0.762
Eq. 8 (Proposed)	Hetrakul (1978) Ratliff (1975) Young (2000) Cornell (1953)	0.999	0.101	1.74	0.880	0.759

In the case of I-sections such as two channel C-sections, the (Hetrakul and Yu, 1978) data was considered separately because the specimens were all double web I-sections made up of two channel C-sections, resulting in Eq. 9. The data from (Winter and Pian, 1946) on the other hand was made up of single and double web specimens. By considering both data sets, Eq. 10 was developed. By comparing Eq. 9 with Eq. 10, one can conclude that there is a noticeable difference in interaction coefficients. Since most of the I-sections used in practice today are double web sections, it would be logical to use Eq. 9 instead of Eq. 10.

Figures A1 to A5 of Appendix A show that the new interaction equations result in an increase in computed strength and the statistical data in Tables 1 to 3 indicates that the new interaction equations provide an improved assessment of the interaction of web crippling and bending strength when compared to the current interaction equations. Insufficient data exists to draw final conclusions for I-sections having unstiffened flanges.

Table 2 - Stiffened Flange I-Sections

Equation	Data Source	Mean	COV	USA & Mexico		Canada
				Ω	ϕ	ϕ
Eq. 2 (Current)	Hetrakul (1978)	1.071	0.094	1.61	0.950	0.820
Eq. 2 (Current)	Hetrakul (1978) Winter (1946)	1.097	0.104	1.59	0.964	0.830
Eq. 9 (Proposed)	Hetrakul (1978)	1.001	0.091	1.72	0.891	0.769
Eq. 10 (Proposed)	Hetrakul (1978) Winter (1946)	0.997	0.110	1.76	0.871	0.748

Table 3 - Nested Z-Sections

Equation	Data Source	Mean	COV	USA & Mexico		Canada
				Ω	ϕ	ϕ
Eq. 3 (Current)	LaBoube (1994)	0.991	0.034	1.68	0.914	0.798
Eq. 11 (Proposed)	LaBoube (1994)	0.998	0.033	1.66	0.921	0.804

7.0 Conclusions and Recommendations

The current web crippling and bending interaction equations in the North American Specification (NAS 2001) have been evaluated using the available data found in the literature. The objective of this study was to evaluate the current interaction equations in light of the recent changes in both the pure web crippling equations and the bending strength determination.

Based on this study, new web crippling and bending interaction equations have been developed. In each case, the typical statistical parameters have been established to substantiate the best data-fit interaction equations. Shown in Table 4 are the recommended interaction equations with their respective factors of safety and resistance factors rounded off to the nearest 0.05.

Table 4 – Recommended Interaction Equations

Equation	Mean	COV	USA & Mexico		Canada
			Ω	ϕ	ϕ
<u>C- and Hat Sections</u>					
$0.91 \left(\frac{P_t}{P_n} \right) + \left(\frac{M_t}{M_n} \right) \leq 1.33$	0.999	0.101	1.70	0.90	0.75
<u>I-Sections</u>					
$0.88 \left(\frac{P_t}{P_n} \right) + \left(\frac{M_t}{M_n} \right) \leq 1.46$	1.001	0.091	1.70	0.90	0.75
<u>Nested Z-Sections</u>					
$0.86 \left(\frac{P_t}{P_n} \right) + \left(\frac{M_t}{M_n} \right) \leq 1.65$	0.998	0.033	1.70	0.90	0.80

8.0 Acknowledgements

The authors wish to thank the American Iron and Steel Institute for their financial support and sponsorship of this research project. We wish to also thank the Canadian Cold Formed Steel Research Group of the Department of Civil Engineering at the University of Waterloo for having provided valuable resources during the course of the project.

9.0 Notation

- C = web crippling coefficient
- C_h = web slenderness coefficient
- C_N = bearing length coefficient
- C_R = inside bend radius coefficient
- D_m = mean dead load intensity ($= 1.05 D_n^*$)
- D_n = nominal dead load intensity
- F_m = mean ratio of actual to specified section modulus
- F_y = yield point of steel
- h = flat dimension of web measured in plane of web
- L_m = mean live load intensity ($= L_n^*$)
- L_n = nominal live load intensity
- N = bearing length [3/4 in. (19 mm) minimum]
- M_m = mean ratio of actual yield point to minimum specified value
- P_m = mean ratio of experimental to calculated results
- R = inside bend radius
- S_e = effective section modulus at $f = F_y$
- t = web thickness
- V_P = coefficient of variation of experimental to calculated results
- V_M = coefficient of variation reflecting material properties' uncertainties
- V_F = coefficient of variation reflecting geometric uncertainties
- V_D = coefficient of variation of the dead load intensities
- V_L = coefficient of variation of the live load intensities
- ϕ = resistance factor
- θ = angle between plane of web and plane of bearing surface $45^\circ \leq \theta \leq 90^\circ$
- Ω = factor of safety (ASD only)

* Values recommended by (Hsiao et al. 1998)

10.0 References

- AISI (1996) American Iron and Steel Institute, *Specification for the Design of Cold-Formed Steel Structural Members*, 1996 Edition, Washington, DC, USA, 1996– Including Supplement No.1, July 30, 1999.
- Cornell University, 65th and 66th Progress Papers on Light Gage Steel Beams of Cold-Formed Steel, September 1952 and January 1953, USA, respectively (unpublished).
- CSA (1994), *Cold Formed Steel Structural Members*, CSA-S136-94, Canadian Standards Association, Rexdale, Ontario, Canada, December 1994.
- Hetrakul, N. and W.W. Yu (1978), “Webs for Cold-Formed Steel Flexural Members Structural Behaviour of Beam Webs Subjected to Web Crippling and a Combination of Web Crippling and Bending,” Final Paper, University of Missouri-Rolla, Rolla, MO, USA, June 1978.
- Hsiao, L., Yu, W. W. and T.V. Galambos (1998), “Load and Resistance Factor Design of Cold-Formed Steel, Calibration of the AISI Design Provisions,” Ninth Progress Paper, Civil Engineering Study 88-2, University of Missouri-Rolla, Rolla, MO, USA, 1998.
- LaBoube, R.A., J. N. Nunnery, and R. E. Hodges (1994), “Web Crippling Behaviour of Nested Z-Purlins,” *Engineering Structures*, (G.J. Hancock, Guest Editor), Vol. 16, No. 5 Butterworth-Heinemann Ltd., London, July 1994.
- NAS (2001), *North American Specification for the Design of Cold-Formed Steel Structural Members*, November 9, 2001 Draft Edition, 1st Printing – February 2002, American Iron and Steel Institute, Washington, DC, USA.
- Ratliff, G.D. (1975), “Interaction of Concentrated Loads and Bending in C-shaped Beams,” *Proceedings of the Third Specialty Conference on Cold-Formed Steel Structures*, University of Missouri-Rolla Rolla, MO, USA.
- Wallace, J.A., R.A. LaBoube and R.M. Schuster (2002), “Web Crippling and Bending Interaction of Cold-Formed Steel Members,” *Canadian Cold Formed Steel Research Group*, Department of Civil Engineering, University of Waterloo, Waterloo, Ontario, Canada.
- Winter, G. and R.H.J. Pian (1946), “Crushing Strength of Thin Steel Webs,” Engineering Experiment Station, Bulletin No. 35, Part 1, Cornell University, April 1946, USA.
- Young, B, and G.J. Hancock (2000), “Experimental Investigation of Cold-Formed Channels Subjected to Combined Bending and Web Crippling,” *Proceedings of the 15th International Specialty Conference on Cold-Formed Steel Structures*, University of Missouri-Rolla, Rolla, MO, USA.

11.0 Appendix A

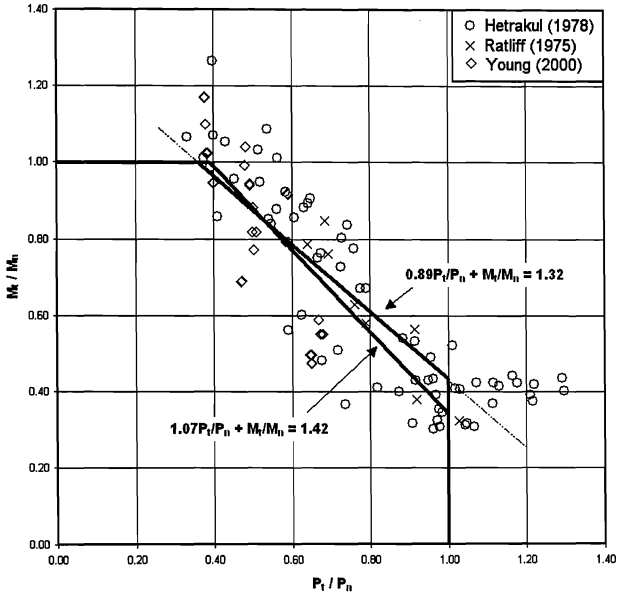

Figure A1: Interaction Diagram of Channel C-sections

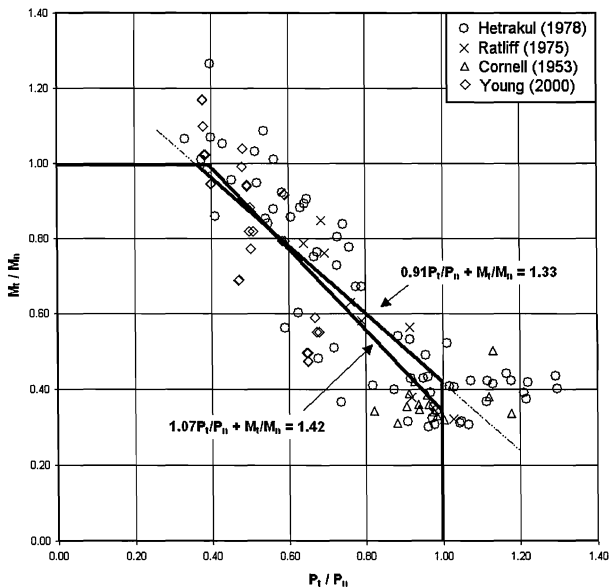

Figure A2: Interaction Diagram of C- and Hat Sections

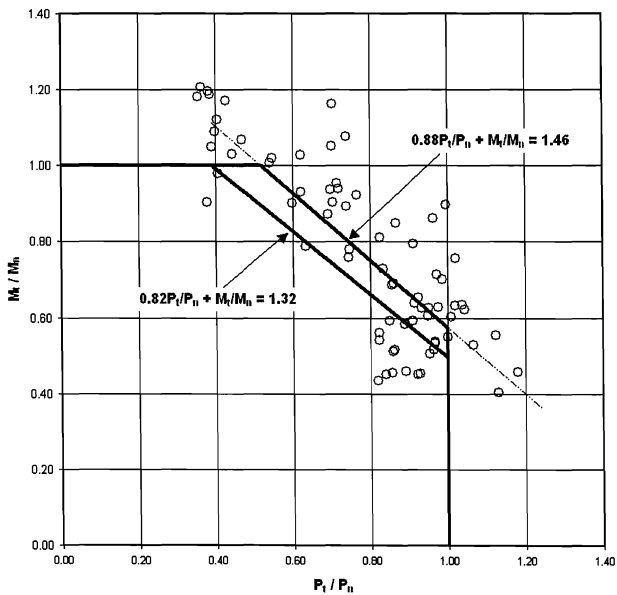

Figure A3: Interaction Diagram of I-sections (Hetrakul and Yu 1978)

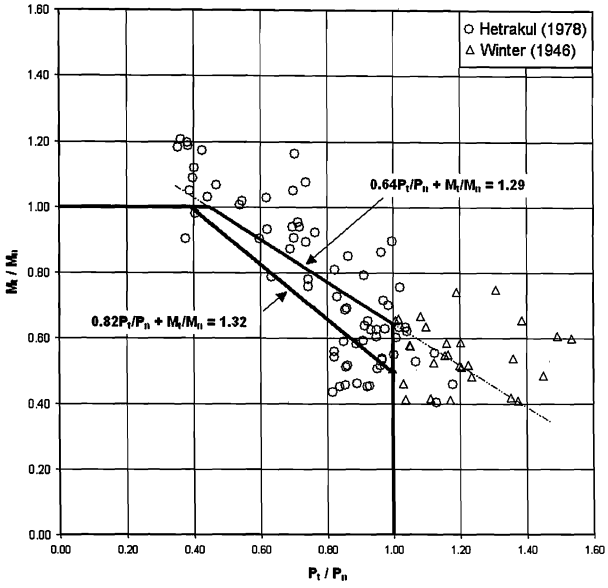

Figure A4: Interaction Diagram of I-sections

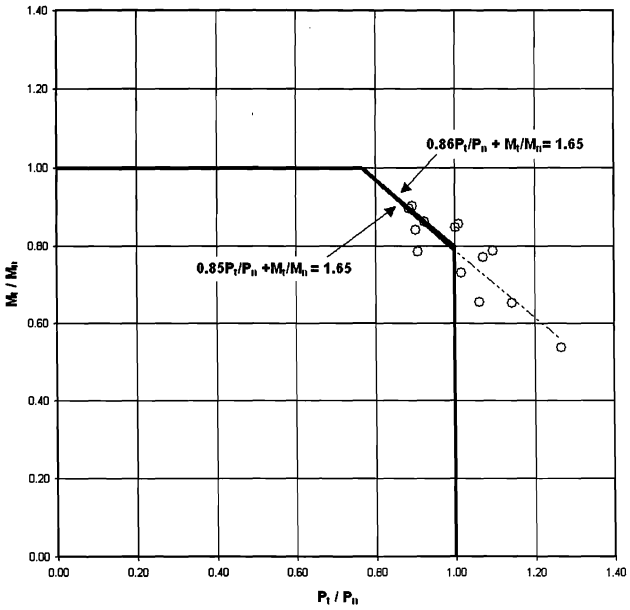

Figure A5: Interaction Diagram of Nested Z-sections (LaBoube et al., 1994)