



Oct 14th, 12:00 AM

## An Update on AISI Standards for Cold-formed Steel Framing

Jay W. Larson

Follow this and additional works at: <https://scholarsmine.mst.edu/isccss>



Part of the [Structural Engineering Commons](#)

---

### Recommended Citation

Larson, Jay W., "An Update on AISI Standards for Cold-formed Steel Framing" (2008). *International Specialty Conference on Cold-Formed Steel Structures*. 1.

<https://scholarsmine.mst.edu/isccss/19iccfss/19iccfss-session3/1>

This Article - Conference proceedings is brought to you for free and open access by Scholars' Mine. It has been accepted for inclusion in International Specialty Conference on Cold-Formed Steel Structures by an authorized administrator of Scholars' Mine. This work is protected by U. S. Copyright Law. Unauthorized use including reproduction for redistribution requires the permission of the copyright holder. For more information, please contact [scholarsmine@mst.edu](mailto:scholarsmine@mst.edu).

## **An Update on AISI Standards for Cold-Formed Steel Framing**

Jay W. Larson, P.E., F.ASCE<sup>1</sup>

### **Abstract**

The Committee on Framing Standards of the American Iron and Steel Institute (AISI) continues its mission to eliminate regulatory barriers and increase the reliability and cost competitiveness of cold-formed steel framing through improved design and installation standards. Its suite of eight ANSI-approved, building code adopted standards and its Code of Standard Practice for Cold-Formed Steel Structural Framing build upon AISI S100, the *North American Specification for the Design of Cold-Formed Steel Structural Members*. This paper provides an overview of the significant documents that have been produced by the AISI Committee on Framing Standards and describes the ongoing work of the committee.

### **Introduction**

AISI has long had a role in standards development. This began with the sponsorship of research at Cornell University under Professor George Winter and the first publication of the AISI *Specification* in 1946. This initial work was started because of difficulties faced in the acceptance and the development of cold-formed steel construction because there were no provisions for it in the U.S. building codes at that time. Since those early beginnings, AISI has engaged a committed group of professionals to expand the body of knowledge and enhance the *Specification* (Yu et al., 1996). The latest edition of the *Specification* is AISI S100, the *North American Specification for the Design of Cold-Formed Steel Structural Members* (AISI, 2007a). This document is adopted in Canada as CSA S136 (CSA, 2007).

---

<sup>1</sup> Managing Director, Construction Technical, AISI.

Standards development is the process of turning research and state-of-the-art practices into standards and building code provisions (Figure 1). The *Specification* and the various design and test standards developed by AISI are different than design guides, technical notes and other non-mandatory publications. Once adopted by building codes, these standards carry the weight of law. Therefore, as a standards developer AISI has an increased obligation and is held to higher scrutiny. Consequently, the standards development activities of AISI are conducted under the auspices of ANSI, the American National Standards Institute.

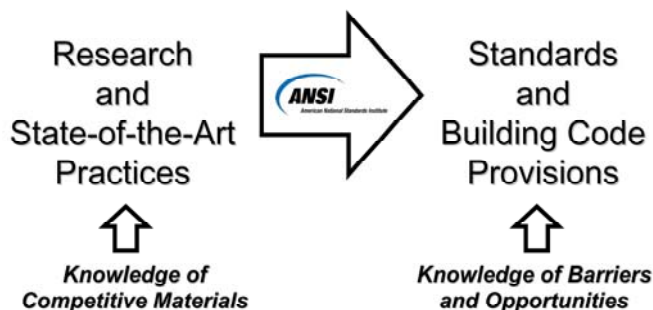

**Figure 1: AISI Standards Development Process**

AISI's standards development activities operate under strict operating procedures. These procedures earned AISI the approval of ANSI as a recognized consensus standards-writing organization. Specific requirements provide for balance between producer, user and general interest categories, voting, including the resolution of negatives, public review, interpretations, and appeals.

AISI serves as Secretariat to two committees (Figure 2). The Committee on Specifications (COS), which has responsibility for the *Specification*, as well as its test procedures, design manual and design guides, and the Committee on Framing Standards (COFS), which was formed in 1997 to take on the responsibility for the new standards needed for the light framing industry. This was done due to the "increased interest in cold-formed steel for residential and light commercial framing" and the sense that "there were a number of design issues that were not adequately addressed for this emerging market. (Bielat and Larson, 2002).



**Figure 2: AISI Consensus Committees**

The COFS established as its mission: “To eliminate regulatory barriers and increase the reliability and cost competitiveness of cold-formed steel framing in residential and light commercial building construction through improved design and installation standards.” The committee also established as its primary objective: “To develop and maintain consensus standards for cold-formed steel framing, manufactured from carbon or low alloy flat rolled steel, that describe reliable and economical design and installation practices for compliance with building code requirements.” A plan was developed to supplement the *Specification* with a series of design and installation standards, which would be used for engineered or prescriptive design.

By 2001, the COFS had completed four standards for cold-formed steel framing on *General Provisions*, *Truss Design*, *Header Design*, and a *Prescriptive Method for One and Two Family Dwellings*. In 2003, a commentary on the *Prescriptive Method*, including design examples, was completed. By the end of 2004 these initial ANSI-accredited documents were updated and new standards on *Wall Stud Design* and *Lateral Design* had been introduced. AISI was well on its way towards “effectively leveraging its experience and expertise in standards development to support the growing needs of the cold-formed steel framing industry” (Larson, 2004). The COFS continued to improve the existing standards and initiated new projects to develop an industry *Code of Standard Practice* and a *Product Data* standard (Larson 2006).

### AISI Framing Standards

In early 2007, AISI gained ANSI approval of a new *North American Standard for Cold-Formed Steel Framing – Product Data*, and updated North American editions of its standards on *General Provisions*, *Header Design* and *Truss Design*. These documents completed AISI editorial and administrative review, and were published in mid-2007 by the Steel Framing Alliance (SFA) as American National Standards. A most noteworthy change is that these were North American standards, intended for adoption and use in Canada and Mexico, as well as the United States. Also, a new numeric designation system was introduced to better reference the documents in codes and specifications. Later in 2007, AISI gained ANSI approval of a new *North American Standard for Cold-Formed Steel Framing – Floor and Roof System Design*, updated North American editions of its standards on *Lateral Design* and *Wall Stud Design*, and an updated edition of its *Prescriptive Method*. Likewise, these documents completed AISI editorial and administrative review, and were published in early 2008 by SFA, completing the suite of 2007 edition ANSI-approved documents (Figure 3).

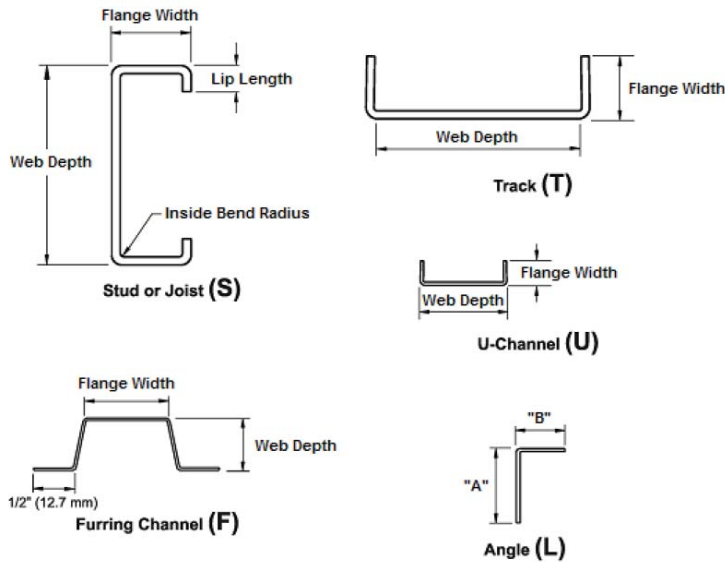

**Figure 3: 2007 Edition AISI Framing Standards**

**AISI S200-07** is the new designation for the revised *General Provisions* standard (AISI, 2007b). This standard addresses those things that are common to prescriptive and engineered design, and applies to the design, construction and installation of structural and non-structural cold-formed steel framing members where the specified minimum base metal thickness is between 18 mils (0.0179 inches) (0.457mm) and 118 mils (0.1180 inches) (3.00mm). It provides general requirements that are not addressed in the *Specification* for material, corrosion protection, products, member design, member condition, installation, and connections.

In this new North American edition, definitions for terms in all the various AISI standards for cold-formed steel framing have been centralized to assure consistency and better facilitate maintenance of the standards. Language was added to clarify that a dissimilar metal may be used in direct contact with steel framing members if approved for that application, and commentary language was added to provide guidance on when such applications might not be a problem. The minimum base metal thickness table was removed, and the thickness requirements now defer to an approved design or recognized product standard, such as the new *Product Data* standard, AISI S201 (below). A requirement was added that when specifying material for use in structural applications, the material used in design is identified on the contract documents and when ordering the material. Referenced document and product identification requirements were updated. Based on recent research, commentary language was also added to provide guidance on both the use of load bearing top track assemblies and the wall stud gap tolerance.

**AISI S201-07** is the designation for the new North American standard on *Product Data* (AISI, 2007c). This standard is intended to establish and encourage the production and use of standardized products in the United States, Canada and Mexico. It provides criteria, including material and product requirements for cold-formed steel C-shape studs, joists, track, U-channels, furring channels and angles intended to be utilized in structural and non-structural framing applications (Figure 4).



**Figure 4: Cold Formed Steel Framing Member Types**

This standard defines standard material grades and specifications, minimum base steel and design thickness, and coatings for corrosion protection. It also defines standard product designator, shapes, inside bend radius, lip length, punchouts, marking and manufacturing tolerances. This standard requires a properly documented quality control program and the proper application of quality assurance procedures.

**AISI S210-07** is the designation for the new North American standard on *Floor and Roof System Design* (AISI, 2007d). This standard is intended for the design and installation of cold-formed steel framing for floor and roof systems in buildings. The standard provides a methodology for continuously braced design; i.e., considering the structural bracing and/or composite-action contribution of attached sheathing or deck. The standard also includes provisions for clip angle bearing stiffeners, based on a recent testing program at the University of Waterloo.

**AISI S211-07** is the new designation for the revised *Wall Stud Design* standard (AISI, 2007e). This standard provides technical information and specifications for designing wall studs made from cold-formed steel. It addresses certain items not presently covered by the *Specification*, including load combinations specific

to wall studs, a rational approach for sheathing braced design, and methodologies to evaluate stud-to-track connections and deflection track connections.

In this new North American edition, the referenced document listing was updated, and the standard and commentary were revised for consistency with other standards and research findings, as well as clarity for the users of the document. There were no substantive changes to U.S. provisions.

**AISI S212-07** is the new designation for the revised *Header Design* standard (AISI, 2007f). This standard provides design and installation requirements for headers made from cold-formed steel for use over door and window openings. The standard covers box and back-to-back headers, as well as double and single L-headers used in single-span conditions for load carrying purposes in buildings. The design methodologies are based on testing at the NAHB Research Center, the University of Missouri-Rolla and industry.

In this new North American edition, the referenced document listing was updated, requirements for evaluating shear were added for back-to-back and box headers, and provisions were included for designing inverted L-header assemblies, based on rational engineering judgment, as a means to provide improved capacity for double and single L-headers (Figure 5).

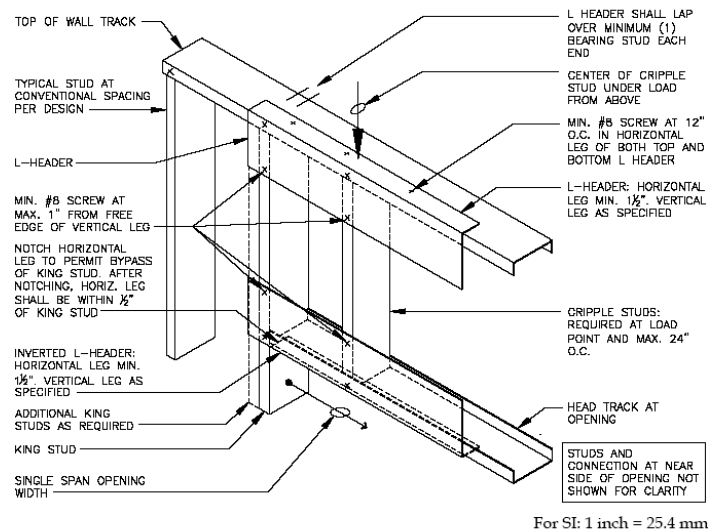

**Figure 5: Inverted L-Header Assembly**



**AISI S213-07** is the new designation for the revised *Lateral Design* standard (AISI, 2007g). This standard addresses the design of lateral force resisting systems to resist wind and seismic forces in a wide range of buildings constructed with cold-formed steel framing. It contains design requirements for shear walls, diagonal strap bracing (that is part of a structural wall) and diaphragms that provide lateral support to a building structure.

In this new North American edition, referenced documents were updated and editorial clarifications were made. Substantive changes were made to the standard and commentary, including provisions for other in-plane lateral loads, shear walls with fiberboard sheathing, and special seismic provisions for diagonal strap bracing, forces contributed by masonry and concrete walls and forces contributed by other concrete or masonry construction.

**AISI S214-07** is the new designation for the revised *Truss Design* standard (AISI, 2007h). This standard provides technical information and specifications on cold-formed steel truss construction, and applies to cold-formed steel trusses used for load carrying purposes in buildings. The standard is not just for design. It also applies to manufacture, quality criteria, installation and testing as they relate to the design of cold formed steel trusses. The requirements of the truss standard apply to both generic C-section trusses, as well as the various proprietary truss systems and were developed, in part, based on extensive research at the University of Missouri-Rolla.

In this new North American edition, the referenced document listing was updated, and the standard and commentary were revised to clarify when members are to be evaluated for axial load alone, bending alone, and combined axial load and bending, and clarify the requirements for trusses with C-shaped chord and web members. Provisions for designing gusset plates were added, based on based on a recent testing program. The required minimum number of test specimens for the full-scale structural performance load test was changed from two to three, and the special beta-factors for trusses were deleted and the user is deferred instead to AISI S100.

**AISI S230-07** is the new designation for the revised *Prescriptive Method* standard (AISI, 2007i). This standard provides prescriptive requirements for cold-formed steel-framed detached one- and two-family dwellings, townhouses, attached multi-family dwellings, and other attached single-family dwellings. It includes numerous tables and details to allow buildings complying with the limitations therein to be constructed. Alternatively such dwellings may be designed by a design professional.

In this new edition, the standard was updated to latest codes and standards, and enhanced in many ways. The allowable number of stories was increased from two to three, and provisions were added for clip angle bearing stiffeners, anchor bolt washers in high wind/seismic areas, gable endwall framing, hip roof framing, single L-headers, inverted L-header assemblies, and grade 50 headers and roof rafters

### **Other Resources**

As mentioned earlier, building code-adopted ANSI-approved standards are not the only documents needed to sustain the increased use of cold-formed steel framing. Practice guides, design guides and technical notes provide invaluable information to designers and building officials. AISI has a significant role in the development of these documents, as well.

#### Code of Standard Practice

Work towards an industry *Code of Standard Practice for the Cold-Formed Steel Structural Framing Industry* began in 2002. The latest edition (AISI, 2006), which includes Commentary, was developed by the COFS, reviewed by several peer committees within the industry, and endorsed by the Association of the Walls and Ceilings industry (AWCI), Steel Framing Alliance (SFA) and Steel Stud Manufacturers Association (SSMA). This document helps define the lines of responsibility in cold-formed steel framing design and construction, which have previously been vague and unclear. Among the many topics covered are general requirements, classification of materials, plans and specifications, installation drawings, materials, manufacture and delivery, installation requirements, quality control, and contractual relations. The document is loosely based on similar documents by the American Institute of Steel Construction (AISC) and Steel Joist Institute (SJI), and was guided by documents by the Steel truss and Component Association (STCA) and the Council of American Structural Engineers (CASE).

#### Cold-Formed Steel Framing Design Guide

In 2007, under the auspices of the COS, the *Cold-Formed Steel Framing Design Guide*, authored by Tom Trestain, was updated (AISI, 2007j). This document provides a basic introduction to design methods, loads and load combinations, design strength determination, member design as a function of bracing and design strength of connections. But the bulk of this document is devoted to the solution of four detailed design examples. Each example starts with the applied loads and illustrates how to analyze load paths, determine member and

connection forces, select members, establish proper bracing conditions, design bracing, and design connections. The detailed design examples cover wind bearing and axial load bearing stud walls and joists, and are based on the *Specification*. A number of methodologies are proposed to handle design problems not covered in the *Specification*, including a rational method to check the warping torsional stresses in channel members, an approximate method to check the bearing stresses under the bottom track of axial load bearing stud wall assemblies and a method to check the strength and stiffness of inner and outer top track assemblies for wind bearing applications. Changes from the previous edition of the design guide are numerous, including use of provisions from the updated *Specification* and COFS framing standards.

#### Steel Stud Brick Veneer Design Guide

In 2003, also under the auspices of the COS, AISI released the *Steel Stud Brick Veneer Design Guide* (AISI, 2003). This document, also authored by Tom Trestain, provides background on the key issues and industry references, provides definitions and explanations of terms, describes the function and behavior of the various components, and provides an understanding of overall system behavior and design considerations. Several design approaches are described and a clear set of recommendations is provided for the designer and installer. The recommendations in the guide are based on significant industry references, which are cited, with particular emphasis on a comprehensive long-term investigation funded by the Canada Mortgage and Housing Corporation. The recommendations include suggestions about the bracing of the stud system, the type of brick ties and what design load must be used for them, the amount of movement that is safely permitted for crack control, and insulating techniques in different climates to help prevent condensation within the wall and encourage drying of wall cavities that may experience some moisture. The document includes a very extensive bibliography. For the designer or builder preparing to install a brick veneer system over steel studs, this resource provides excellent insight into how the system should be designed, detailed and installed. Proper anticipation, mitigation and management of heat, air and moisture within the wall system can go a long way to preserving the integrity of the overall building.

#### CFSEI Technical Notes

The Cold-Formed Steel Engineers Institute (CFSEI) has as its mission; “*To enable and aid engineers in the efficient structural design of safe and cost effective cold-formed steel (CFS) framed structures.*” Of its eight key strategies, first and foremost is the production of technical documents that enable and aid engineers. The CFSEI Technical Note series is the focal point of this strategy.

These concise documents cover design, specification, installation and inspection on a broad range of design issues, including seismic, wind, fire, acoustic, bracing, fastening, deflection and durability. AISI works closely with CFSEI, through the COFS, to support and encourage the development of these Technical Notes and other design resources for the industry. Membership by design professionals in CFSEI is encouraged, as this organization offers local chapter activities, provides timely and competent response to technical inquiries, provides forums for the exchange of information and ideas, partners with aligned organizations, helps focus research spending on the needs of engineers and works to develop awareness of cold-formed steel framing through the formal education system.

### Conclusions

The AISI Committee on Framing Standards (COFS) has continued with earnest its mission to eliminate regulatory barriers and increase the reliability and cost competitiveness of cold-formed steel framing through improved design and installation standards.

The COFS has built on the internationally recognized AISI *Specification* and has developed and published eight ANSI-accredited consensus standards, including:

- AISI S200: General Provisions
- AISI S201: Product Data
- AISI S210: Floor and Roof System Design
- AISI S211: Wall Stud Design
- AISI S212: Header Design
- AISI S213: Lateral Design
- AISI S214: Truss Design
- AISI S230: Prescriptive Method

AISI has also facilitated the development of a much-appreciated industry code of standard practice and useful design guides for cold-formed steel framing and steel stud brick veneer construction. In addition, AISI supports and encourages the Cold Formed Steel Engineers Institute (CFSEI) in the development of technical notes on a broad range of design issues.

These documents are readily available from the Steel Framing Alliance ([www.steel framing alliance.com](http://www.steel framing alliance.com)).

### **Acknowledgements**

The members of the AISI committees, subcommittees and task groups responsible for bringing these documents to fruition are to be commended for their time and effort. It is through the participation of representatives from steel producers, fabricators, users, educators, researchers, and building code officials in this consensus process that such progress is made. The partner organizations; i.e., Steel Framing Alliance, Cold-Formed Steel Engineers Institute, Steel Stud Manufacturers Association, Canadian Sheet Steel Building Institute and Center for Cold Formed Steel Structures are to be thanked for their active participation. Particular gratitude is owed to the member companies of the American Iron and Steel Institute for their long-term vision for this market and financial support of this technical effort.

AISI's Construction Market Companies include AK Steel Corporation, ArcelorMittal Dofasco Inc., IPSCO Inc., ArcelorMittal, Nucor Corporation, Severstal North America Inc., Steelscape, Inc., Stelco Inc., United States Steel Corporation and USS-POSCO Industries.

### References

- (AISI, 2003), *Steel Stud Brick Veneer Design Guide*, CF03-1, American Iron and Steel Institute, Washington, D.C., 2003.
- (AISI, 2006), *Code of Standard Practice for Cold-Formed Steel Structural Framing*, CF-06-1, American Iron and Steel Institute, Washington, D.C., 2006.
- (AISI, 2007a), *North American Specification for the Design of Cold-Formed Steel Structural Members*, AISI S100-07, American Iron and Steel Institute, Washington, D.C., 2007.
- (AISI, 2007b), *North American Standard for Cold-Formed Steel Framing – General Provisions*, AISI S200-07, American Iron and Steel Institute Washington, D.C., 2007.
- (AISI, 2007c), *North American Standard for Cold-Formed Steel Framing – Product Data*, AISI S201-07, American Iron and Steel Institute, Washington, D.C., 2007.
- (AISI, 2007d), *North American Standard for Cold-Formed Steel Framing – Floor and Roof System Design*, AISI S210-07, American Iron and Steel Institute, Washington, D.C., 2007.
- (AISI, 2007e), *North American Standard for Cold-Formed Steel Framing – Wall Stud Design*, AISI S211-07, American Iron and Steel Institute, Washington, D.C., 2007.
- (AISI, 2007f), *North American Standard for Cold-Formed Steel Framing – Header Design*, AISI S212-07, American Iron and Steel Institute, Washington, D.C., 2007.
- (AISI, 2007g), *North American Standard for Cold-Formed Steel Framing – Lateral Design*, AISI S213-07, American Iron and Steel Institute Washington, D.C., 2007.
- (AISI, 2007h), *North American Standard for Cold-Formed Steel Framing – Truss Design*, AISI S214-07, American Iron and Steel Institute, Washington, D.C., 2007.
- (AISI, 2007i), *Standard for Cold-Formed Steel Framing – Prescriptive Method for One and Two Family Dwellings*, AISI S230-07, American Iron and Steel Institute Washington, D.C., 2007.
- (AISI, 2007j), *Cold-Formed Steel Framing Design Guide*, D110-07, American Iron and Steel Institute, Washington, D.C., 2007.

Bielat, K.R., Larson, J.W. (2002), "AISI Committee on Framing Standards – Enabling the Widespread and Economic Use of Steel Framing", *Proceedings of the 16<sup>th</sup> International Specialty Conference on Cold-Formed Steel Structures*, St. Louis, MO, 2002.

(CSA, 2007), *North American Specification for the Design of Cold-Formed Steel Structural Members*, CAN/CSA S136-07, Canadian Standards Association, Mississauga, Ontario, Canada, 2007.

Larson, J.W. (2004), "An Update on Cold-Formed Steel Framing Standards Development in the United States", *Proceedings of the 17<sup>th</sup> International Specialty Conference on Cold-Formed Steel Structures*, Orlando, FL, 2004.

Larson, J.W. (2006), "AISI Standards for Cold-Formed Steel Framing", *Proceedings of the 18<sup>th</sup> International Specialty Conference on Cold-Formed Steel Structures*, Orlando, FL, 2006.

Yu, W.W., Wolford, D.S., Johnson, A.L. (1996), "Golden Anniversary of the AISI Specification", *Proceedings of the 13<sup>th</sup> International Specialty Conference on Cold-Formed Steel Structures*, St. Louis, MO, 1996.



