

14 Apr 2010

Siding Attachment to Cold-Formed Steel Walls through Varying Layers of Foam Insulation

Newport Ventures, Inc.

Applied Residential Engineering Services

Follow this and additional works at: <https://scholarsmine.mst.edu/ccfss-library>



Part of the [Structural Engineering Commons](#)

Recommended Citation

Newport Ventures, Inc. and Applied Residential Engineering Services, "Siding Attachment to Cold-Formed Steel Walls through Varying Layers of Foam Insulation" (2010). *CCFSS Library (1939 - present)*. 241. <https://scholarsmine.mst.edu/ccfss-library/241>

This Technical Report is brought to you for free and open access by Scholars' Mine. It has been accepted for inclusion in CCFSS Library (1939 - present) by an authorized administrator of Scholars' Mine. This work is protected by U. S. Copyright Law. Unauthorized use including reproduction for redistribution requires the permission of the copyright holder. For more information, please contact scholarsmine@mst.edu.

REPORT

SIDING ATTACHMENT TO COLD-FORMED STEEL WALLS THROUGH VARYING LAYERS OF FOAM INSULATION

APRIL 2010

NEWPORT  VENTURES

ARES
CONSULTING SERVICES

SIDING ATTACHMENT TO COLD-FORMED STEEL WALLS THROUGH VARYING LAYERS OF FOAM INSULATION

**Final report on project funded cooperatively by the Steel Framing Alliance and
the New York State Energy Research and Development Authority**

Prepared by
Newport Ventures, Inc.
Schenectady, NY

And

Applied Residential Engineering Services
West River, MD

Prepared for
The Steel Framing Alliance
Washington, DC

April 14, 2010

SIDING ATTACHMENT TO COLD FORMED STEEL WALLS THROUGH VARYING LAYERS OF FOAM INSULATION

Introduction

When insulating an exterior wall, more and more codes are requiring continuous insulation on the exterior of the studs to reduce the effect of thermal bridging. As energy codes continue to become more stringent, the thickness of the continuous installation has increased. Although wood and steel are both impacted, the requirements generally are higher for steel framing.

A significant implementation challenge caused by increasingly higher levels of continuous insulation is the lack of specifications for the type of fastener and siding installation details that should be used when installing thicker levels of insulation. Thus, the engineer, architect, builder, and contractor are left to confront this challenge without clear guidance. Without clear building code requirements, the builder and code official also face the potential for conflicting code requirements between the building section of the code, which often cites manufacturer instructions, and the energy section of the code that goes beyond the scope of the same instructions.

The overall objective of this project was to develop attachment techniques for securing building cladding and continuous insulation to above-grade, steel framed walls of single family and multifamily buildings up to seven stories. The project was funded jointly by the Steel Framing Alliance (SFA) and the New York State Energy Research and Development Authority (NYSERDA), and thus considers requirements in national model codes produced by the International Code Council and the New York State Building Code.

The project consisted of three main tasks. Task 1 included a review of code requirements related to siding attachment. The findings were used to identify potential options for siding attachment. Task 2 is an assessment of the practical construction issues associated with the options identified in Task 1.

Task 3 includes the results of engineering analysis and structural tests conducted on the most promising options. The intention of this task was to develop a methodology and apply it to the development of prescriptive fastener requirements for steel framing. At the start of the project, an opportunity to work with the Foam Sheathing Coalition (FSC) was identified to accelerate the introduction of project findings into building codes through a Public Comment to the International Code Council (ICC) for consideration at their May 2010 Final Action hearings. Thus, Task 3 was expanded to work with the FSC to modify a comprehensive code change proposal they had previously submitted to the ICC.

The remaining sections of this report consist of the three task reports. A summary of the findings of each task is provided in the section on each task report. The most significant result of the project is prescriptive requirements for building codes. These are included at the end of the section on Task 3.

TASK 1

CODE REQUIREMENTS FOR CLADDING FASTENING

Introduction

Objective and scope

The amount of continuous insulation is dictated by building energy codes, and generally determined according to building type, framing material, and climate zone. For example, the New York Energy Conservation and Construction Code's (NYECCC) current requirements for R-values of continuous insulation for commercial and multi-family buildings range from zero to 7.5 depending on climate zone and building type. These values are based on prescriptive requirements of ASHRAE 90.1-2004 (the most widely referenced standard for building energy codes in the nation), which is referenced by the NYECCC. Looking forward, ASHRAE 90.1- 2007 requires a minimum of R-7.5 of continuous insulation for all above-grade steel framed walls in New York, regardless of climate zone. ASHRAE is now in process of drafting 90.1-2010, and is considering further substantial increases in the continuous insulation requirements for exterior walls – increases which are likely to eventually apply to New York State buildings.

Under this first task, a review of building codes has been conducted to identify requirements for fasteners. Emphasis was given to vinyl, fiber-cement, and wood siding because these are the predominant cladding types. Also, traditional stucco has been included within the scope of this study. EIFS (Exterior Insulation Finishing Systems – sometimes erroneously called synthetic stucco) were considered outside the scope of the project because these systems rely on different fastening technology and already have solutions for up to 4 inches of foam insulation.

Five codes were the subject of a review under this task. These include the 2007 New York Energy Conservation Construction Code (NYECCC), the 2007 New York Residential Code (NYRC), the 2009 International Residential Code (IRC), 2007 New York Building Code (NYBC), and the 2009 International Building Code (IBC). Of these, two codes contained language that directly impact fastener selection in New York State: the NYRC and the NYBC. Because the NYRC and NYBC are based on the 2006 IRC and 2006 IBC, it is assumed that as NY codes are updated in the future, those updates will continue to be based on future versions of the IRC and IBC. Further, future versions of the IRC and IBC are expected to continue to offer more informative text than previous versions. Therefore, to compile the most updated building code text on performance requirements for fasteners, excerpts were taken from the 2009 IRC and 2009 IBC.

Residential Code Language

Excerpts from applicable codes on language related to siding attachment are provided as follows:

2009 IRC - Section R703 Exterior Covering (ICC, 2009a)

R703.4 Attachments. Unless specified otherwise, all wall coverings shall be securely fastened in accordance with Table R703.4 or with other approved aluminum, stainless steel, zinc-coated or other approved corrosion-resistive fasteners. Where the basic wind speed per Figure R301.2 (4) is 110 miles per hour (49 m/s) or higher, the attachment of wall coverings shall be designed to resist the component and cladding loads...adjusted for height and exposure...

R703.1.2 Wind resistance. Wall coverings, backing materials and their attachments shall be capable of resisting wind loads... Wind-pressure resistance of the siding and backing materials shall be determined by ASTM E 330 or other applicable standard test methods. Where wind-pressure resistance is determined by design analysis, data from approved design standards and analysis conforming to generally accepted engineering practice shall be used to evaluate the siding and backing material and its fastening. All applicable failure modes including bending, rupture of siding, fastener withdrawal, and fastener head pull-through shall be considered in the testing or design analysis. Where the wall covering and the backing material resist wind load as an assembly, use of the design capacity of the assembly shall be permitted.

R703.10.1 (Fiber cement) Panel siding. ..Vertical and horizontal joints shall occur over framing members and shall be sealed with caulking, covered with battens or shall be designed to comply with Section R703.1. Panel siding shall be installed with fasteners according to Table R703.4 or approved manufacturer's installation instructions.

R703.10.2 (Fiber cement) Lap siding... Lap siding shall be lapped a minimum of 11/4 inches (32 mm) and lap siding not having tongue-and-groove end joints shall have the ends sealed with caulking, installed with an H-section joint cover, located over a strip of flashing or shall be designed to comply with Section R703.1. Lap siding courses may be installed with the fastener heads exposed or concealed, according to Table R703.4 or approved manufacturers' installation instructions.

R703.11.1 (Vinyl siding) Installation. Vinyl siding, soffit and accessories shall be installed in accordance with the manufacturer's installation instructions.

R703.11.2 Foam plastic sheathing. Vinyl siding used with foam plastic sheathing shall be installed in accordance with Section R703.11.2.1, R703.11.2.2, or R703.11.2.3.
Exception: Where the foam plastic sheathing is applied directly over wood structural panels, fiberboard, gypsum sheathing or other approved backing capable of independently resisting the design wind pressure, the vinyl siding shall be installed in accordance with Section R703.11.1.

R703.11.2.1 Basic wind speed not exceeding 90 miles per hour and Exposure Category B. Where the basic wind speed does not exceed 90 miles per hour (40 m/s), the Exposure Category is B and gypsum wall board or equivalent is installed on the side of the wall opposite the foam plastic sheathing, the minimum siding fastener penetration into wood framing shall be 11/4 inches (32 mm) using minimum 0.120-inch diameter nail (shank) with a minimum 0.313-inch diameter head, 16 inches on center. The foam plastic sheathing shall be minimum 1/2-inch-thick (12.7 mm) (nominal) extruded polystyrene per ASTM C578, 1/2-inch-thick (12.7 mm) (nominal) polyisocyanurate per ASTM C1289, or 1-inch-thick (25 mm)(nominal) expanded polystyrene per ASTM C578.

R703.11.2.2 Basic wind speed exceeding 90 miles per hour or Exposure Categories C and D. Where the basic wind speed exceeds 90 miles per hour (40 m/s) or the Exposure

Category is C or D, or all conditions of Section R703.11.2.1 are not met, the adjusted design pressure rating for the assembly shall meet or exceed the loads listed in Tables R301.2(2) adjusted for height and exposure using Section R301.2(3). The design wind pressure rating of the vinyl siding for installation over solid sheathing as provided in the vinyl siding manufacturer's product specifications shall be adjusted for the following wall assembly conditions:

1. For wall assemblies with foam plastic sheathing on the exterior side and gypsum wall board or equivalent on the interior side of the wall, the vinyl siding's design wind pressure rating shall be multiplied by 0.39.
2. For wall assemblies with foam plastic sheathing on the exterior side and no gypsum wall board or equivalent on the interior side of wall, the vinyl siding's design wind pressure rating shall be multiplied by 0.27.

R703.11.2.3 Manufacturer specification. Where the vinyl siding manufacturer's product specifications provide an approved design wind pressure rating for installation over foam plastic sheathing, use of this design wind pressure rating shall be permitted and the siding shall be installed in accordance with the manufacturer's installation instructions.

Residential Commentary: Table R703.4 is only relevant when selecting fasteners for attachment of wall coverings to wood framing, and does not apply to selection of fasteners for attachment of wall coverings directly to steel framing. While no prescriptive information is provided for attachment to steel framing, the 2009 IRC has identified relevant test methodology that should be pursued (e.g. ASTM E 330), deferring to engineering design regardless of the framing material when the basic wind speed exceeds 110 mph (R703.4). The IRC also provides some prescriptive fastener information for continuous insulation (i.e. foam plastic sheathing), but does not provide the same level of prescriptive detail for fasteners to attach siding over continuous insulation. In these cases, the IRC often defers to manufacturer recommendations for fastener selection. Finally, the IRC permits the IBC to be used as an alternative compliance path when using engineering analysis to demonstrate ability of the building to withstand design loads (R301.1.1).

Building Code Language (non-residential)

2009 IBC - Chapter 14 - Exterior Walls (ICC, 2009a)

1403.4 Structural. Exterior walls, and the associated openings, shall be designed and constructed to resist safely the superimposed loads required by Chapter 16 (*note: Chapter 16 addresses structural design, including dead, live, seismic, and wind loads*).

1405.14 Vinyl siding. Vinyl siding conforming to the requirements of this section and complying with ASTM D 3679 shall be permitted on exterior walls of buildings located in areas where the basic wind speed specified in Chapter 16 does not exceed 100 miles per hour (45 m/s) and the building height is less than or equal to 40 feet (12 192 mm) in Exposure C. Where construction is located in areas where the basic wind speed exceeds 100 miles per hour (45 m/s), or building heights are in excess of 40 feet (12 192 mm), tests or calculations indicating compliance with Chapter 16 shall be submitted. Vinyl siding shall be

secured to the building so as to provide weather protection for the exterior walls of the building.

1405.14.1 Application. The siding shall be applied over sheathing or materials listed in Section 2304.6... Siding and accessories shall be installed in accordance with approved manufacturer's instructions. Unless otherwise specified in the approved manufacturer's instructions, nails used to fasten the siding and accessories shall have a minimum 0.313-inch (7.9 mm) head diameter and 1/8-inch (3.18 mm) shank diameter. The nails shall be corrosion resistant and shall be long enough to penetrate the studs or nailing strip at least 3/4 inch (19 mm). Where the siding is installed horizontally, the fastener spacing shall not exceed 16 inches (406 mm) horizontally and 12 inches (305 mm) vertically. Where the siding is installed vertically, the fastener spacing shall not exceed 12 inches (305 mm) horizontally and 12 inches (305 mm) vertically.

1405.16 Fiber-cement siding. Fiber-cement siding complying with Section 1404.10 shall be permitted on exterior walls of Type I, II, III, IV and V construction for wind pressure resistance or wind speed exposures as indicated by the manufacturer's listing and label and approved installation instructions. Where specified, the siding shall be installed over sheathing or materials listed in Section 2304.6 and shall be installed to conform to the water-resistive barrier requirements in Section 1403. Siding and accessories shall be installed in accordance with approved manufacturer's instructions. Unless otherwise specified in the approved manufacturer's instructions, nails used to fasten the siding to wood studs shall be corrosion-resistant round head smooth shank and shall be long enough to penetrate the studs at least 1 inch (25 mm). For metal framing, all-weather screws shall be used and shall penetrate the metal framing at least three full threads.

1405.16.1 Panel siding... Vertical and horizontal joints shall occur over framing members and shall be sealed with caulking, covered with battens or shall be designed to comply with Section 1403.2. Panel siding shall be installed with fasteners in accordance with the approved manufacturer's instructions.

1405.17 Fastening. Weather boarding and wall coverings shall be securely fastened with aluminum, copper, zinc, zinc-coated or other approved corrosion-resistant fasteners in accordance with the nailing schedule in Table 2304.9.1 or the approved manufacturer's installation instructions. Shingles and other weather coverings shall be attached with appropriate standard- shingle nails to furring strips securely nailed to studs, or with approved mechanically bonding nails, except where sheathing is of wood not less than 1-inch (25 mm) nominal thickness or of wood structural panels as specified in Table 2308.9.3(3).

Discussion of Code Requirements

The preceding code excerpts focused on the specific sections dealing with fastener selection. There are numerous other sections related to siding and cladding that are not shown as they generally cover other design issues such as weather resistant coverings. This discussion focuses on the load requirements of fasteners.

Of the residential and building codes reviewed, the 2009 IRC provides the most guidance to a designer when specifying fasteners for attaching siding to steel framing, in that it specifies the relevant classes of loads (component and cladding) and the testing methodology to follow when determining wind loads (ASTM E330). Other than this guidance, the code generally defers to manufacturers to provide guidance on fasteners selection. Further, wind loads are only one of the loads that must be considered when designing a fastener. Codes generally prescribe minimum loads capacities for materials and assemblies based on flood, seismic, wind, dead, snow, and live loads (e.g. loads affected by building occupancy). For siding attachment within the scope of this study (vinyl or aluminum, traditional stucco, wood, and fiber-cement), only seismic, wind, and dead loads are relevant.

Seismic loads can be determined based on seismic maps supplied in the NYBC or IBC. Chapter 16 of the IBC requires cladding to resist seismic loads (1604.9) and provides a reference to calculation methodology for seismic loads on various building components. In general, ASCE 7-05, “Minimum Design Loads for Buildings and Other Structures”, is the source that the IBC references for determining seismic loads for all building components, including cladding. Based on a review of ASCE 7-05, resistance to seismic loads is provided by embedment of the fastener into substrate. Hence, increasing the depth of the continuous insulation installed under the cladding will not affect the standard methodology which is now followed for determining performance requirements of cladding fasteners.

Wind loads are determined based on wind zone maps supplied in both the NYBC and NYRC (see attachment 1 for wind zone maps). With fasteners, the primary concern with wind is the fastener’s ability to resist pull out forces that affect the embedment of the fastener in the stud or sheathing. Chapter 16 of the 2009 IBC also references ASCE 7-05 for the calculation of wind loads that are expected to be experienced by cladding. For the case of fasteners attached to steel framing, AISI S100-07, “North American Specification for the Design of Cold-Formed Steel Structural Members,” has provisions to determine the screw pull-out strength. Additionally, AISI S200-07, “North American Standard for Cold-Formed Steel Framing - General Provisions,” states that screw fasteners shall extend through the steel connection a minimum of three (3) exposed threads. The AISI S100-07 provisions are applicable to screws with 0.08 inch to 0.25 inch nominal diameter and the AISI S100-07 provisions are applicable to steel thicknesses from 0.018 inch to 0.118 inch. For the case of fasteners attached to wood based substrate combinations (e.g. sheathing or sheathing + stud), ANSI/AF&PA NDS-2005 “National Design Specification for Wood Construction”, which is referenced in the 2009 IRC, 2007 NYRC, 2009 IBC, and 2007 NYBC, provides guidance for resisting pull out forces. This standard provides a calculation procedure for specification of fasteners depth, size, and schedule as a function of depth of penetration into the wood substrate.

Thus, for most circumstances, wind and seismic loads on cladding can be identified by referencing current codes and standards. Because wind and seismic loads are resisted by embedment of fasteners into wood or steel structural members, and because methodology has been developed for determining the required embedment, conventional methods can be followed to develop prescriptive fastener requirements to resist wind and seismic loads or otherwise designed or tested to meet the required loads. Therefore, the only unresolved structural concern with adding a thick layer of continuous insulation to the wall assembly is whether the cladding fastener can withstand the dead

load from the weight of the siding and continuous insulation (which results in a shear load applied to the fastener). As shown in the previous code excerpts, the IBC and IRC typically defer either to engineering analysis or to manufacturer instructions for cladding fastener specification. A review of manufacturer recommendations is therefore necessary to understand prescriptive fastener requirements for siding.

Manufacturer Recommendations

Numerous siding manufacturers were contacted, and installation manuals were referenced to compile a listing of the fasteners typically referenced within specific siding installation instructions. As shown in Table 1.1, a list of six siding options are given in the first column with common fastener options listed to the right. These are suggested fastening recommendations only. Pull-out or withdrawal capacity of the selected fastener should be verified with respect to anticipated wind load, desired safety factor, and building code requirements. Although not part of the scope of this project, brick and stone requirements are shown for comparison purposes. Though nails are generally not used for attachment of siding directly to steel studs, they are included in the following table to allow for assemblies where siding could be fastened to wood furring strips which are fastened to steel studs. Note that many manufacturer installation instructions limit the thickness of continuous insulation to 1 inch. It is assumed that this current limitation is based on lack of knowledge of the shear resistance of a fastener when installed into framing through a layer of foam sheathing with a greater thicknesses. This project seeks to address this limitation by developing appropriate solutions.

Table 1.1: Industry or Manufacturer Fastener Recommendations

	Screws	Nails	Pins	Miscellaneous
Vinyl Siding (VSI, 2007)	<p>Use noncorrosive, self-tapping screws at least 1-1/8" long, with at least 3/8" dia. head and 1/8" dia. shaft.</p> <p>Screws should penetrate a minimum of 3/4" into framing or furring and should be size #8, truss head or pan head.</p>	<p>Nail heads should be 5/16" minimum in diameter. Shank should be 1/8" in diameter.</p> <p>Nails should penetrate a minimum of 3/4" into a nailable surface.</p>	<p>Staples must not be less than 16-gauge semi-flattened to an elliptical cross-section.</p> <p>Pins should penetrate not less than 3/4" into framing or furring.</p>	<p>ASTM D4756-06, Standard Practice for Installation of Rigid Poly(Vinyl Chloride) (PVC) Siding and Soffit, provides standard guidance, but also defers to manufacturer installation instructions.</p> <p>For all fasteners, allow approximately 1/32" clearance between the fastener head and the siding panel.</p>

	Screws	Nails	Pins	Miscellaneous
Fiber Cement (CT, 2008)	<p>Ribbed, bugle-head corrosive-resistant screws, (#8-18, 1-5/8" 16ga x 0.375" HD)</p> <p>Fiber cement must be attached to the metal framing members (recommended at 16" o.c.). Screws must penetrate into the metal framing a minimum of 1/4" or three threads.</p>	<p>Non-corrosive double hot-dipped galvanized or stainless steel nails.</p> <p>The nail head must lay on the surface of the siding – do not over-drive the nails or nail on angle.</p>	<p>Pneumatic pins are available for certain applications.</p> <p>ET & F Panelfast® nails or equivalent (0.10" shank x 0.313" HD x 1-1/2" long). Nails must penetrate minimum 1/4" into metal framing (JH, 2008)</p>	<p>Do not use D-head nails, staples and/or construction adhesives to install fiber cement siding.</p>
Wood Lap (WRCLA, 2007)	<p>0.23" dia. trim head with #3 drill point - tapping screw thread, threaded 2/3 of overall length</p> <p>“When wood siding is installed over metal studs, provide 2x nailers of sufficient spacing and size to meet the nailing requirements. This procedure is sometimes used when wood siding is installed over continuous insulation.”</p>	<p>The diameter of nail is dependent upon the type and thickness of siding. Use corrosion resistant nails with sufficient length to penetrate wood to a minimum depth of 1 ¼ inches.</p> <p>For best results, use “splitless” ring shank siding nails, which have thin shanks and blunt points to reduce splitting.</p>	<p>No recommendations found.</p>	<p>“Rigid foam sheathing can cause moisture to accumulate on the back of siding and cause staining, buckling and damage to finish coats. As a result, it is recommended that furring strips are used to create an air space between the sheathing and siding” (regardless of whether the structural framing is wood or steel)</p>

	Screws	Nails	Pins	Miscellaneous
Anchored Brick and Stone Veneer	<p>Attach drill bolt/U-clip/ triangle tie assembly anchor to the steel stud web with self-tapping 10-16 x 1-1/2" hex head screws with a 5/8" galvanized bonded E.P.D.M. washer and a 5/16" hex washer head.</p> <p>Various drill bolt and triangle tie lengths are available to accommodate sheathing up to 4-1/2" thick. Drill Bolts are 1/2" dia. U-Clip is 14 gage. (Heckman, 2009)</p>	No recommendations found.	No recommendations found.	Anchors and ties should connect directly to the steel stud framing without relying on the compressive strength of insulating sheathing to transfer positive wind pressure to the steel studs (Owens Corning, 2006)
Direct Adhered Brick and Stone Veneer (Environmental StoneWorks, 2008)	<p>Self tapping screws with minimum 3/8" head of sufficient length to penetrate at least 3/8" beyond metal surface. The lath must be anchored with corrosion resistant screws that have a minimum shank dia. of 0.190".</p> <p>Screws shall be an approved type long enough to penetrate into wood framing not less than 5/8"</p>	4D nail with a 1/4"-7/16" head depending on lath choice.	No recommendations found.	<p>Staples can be used to attach lath if the crown is a minimum of 7/8" with a leg length of 7/8"-1 5/8" dependent on lath choice.</p> <p>OSB or plywood should be attached securely to metal studs according to code requirements.</p>

	Screws	Nails	Pins	Miscellaneous
Stucco (Mediterranean Colors)	Minimum #8 Type S or S-12 wafer head, fully threaded, corrosion resistant screws with minimum 3/8" penetration into studs.	Wood Framing- -minimum 11 gauge, 7/16" dia. head, galvanized roofing nails with minimum 3/4" penetration into studs; or minimum #8 Type S wafer head, fully threaded, corrosion resistant screws with minimum 3/4" penetration into studs.	No recommendations found.	Tie wire—18 gauge galvanized and annealed low-carbon steel in compliance with ASTM A 641 with Class I coating.

In addition to the recommendations in the table above, some other installation instructions should be considered for specific siding types including:

Vinyl Siding

- “Vinyl siding must be applied over a rigid sheathing that provides a smooth, flat surface or an underlayment (such as wood, wood composition, rigid foam or fiber sheathing) that is no more than 1" thick. Vinyl siding cannot be applied directly to studs.” (CT, 2009)

Fiber Cement

- "Siding must be installed to structural framing when using non-structural sheathing. Non-structural sheathing thickness should not exceed 1"... Take extra care when installing fiber cement over foam sheathings. Foam sheathings may crush, especially when they are hand-nailed...If fiber cement siding is installed over a non-nailable substrate such as foam sheathing, pre-drill the holes at the corners to avoid accidental breakage. Panels must be nailed into structural framing (16" or 24" O.C.)." (CT, 2008)
- “It is recommended that siding be fastened into studs or framing. Refer to ICC-ES report ESR-1668...for specific fastening recommendations. Fastening into other structural materials may be acceptable if in accordance with local building codes and/or project conditions.” (CT 2008).

Wood Lap (WRCLA, 2007)

- “Stainless steel nails are the best choice, especially if the siding is to be finished with transparent or semitransparent stain. Use No. 304 stainless for general siding applications and

No. 316 for seacoast exposures... Hot-dipped galvanized, as per ASTM A 153, aluminum and stainless steel fasteners are corrosion-resistant and can be used to fasten Western Red Cedar. Other types of fasteners (including electroplated and mechanically galvanized) are not recommended.”

- Hand nailing is preferred over pneumatic nailers, and pre-drilling at mitered corners, near edges and near ends, may be necessary to avoid splitting.
- “Siding should be fastened to each stud or blocking with nails spaced at a maximum of 24 inches on center. Nail placement depends on the siding pattern and width...fasten the siding securely without preventing it from moving in response to the moisture content in the air.”

Dead Load of Siding

As mentioned previously, fastener choice is highly dependent on the weight of the siding material as foam sheathing thickness increases.. The table below contains the weights of common siding materials. Note that this project focuses on vinyl, fiber cement, wood lap, and three-coat stucco, although some adhered masonry veneer products fall under the applicability limits of 25 psf set in later parts of the project.

Siding Material	Typical Weight of Siding Material
Vinyl Siding	1.4-1.6 PSF
Fiber Cement	2.3 PSF
Wood Lap	2.5-3.1 PSF
Anchored Brick and Stone Veneer	47.0 PSF
Direct Adhered Brick and Stone Veneer	9.0-15.0 PSF
Stucco	10.4 PSF

The range of weights in the table above complicate the later task of developing recommendations for fastening siding over continuous insulation independent of siding type. Selecting the highest weight would be conservative but would penalize materials like vinyl at the lower end of the weight spectrum. A more reasonable approach for the later task would be to develop a range of fastener solutions according to a range of weights. For example, one set of fastener solutions could be developed for lightweight siding, perhaps 3 PSF or lower. Similarly, solutions for a middle range and for heavy materials could be developed.

Fastener Options

Taking the loads and current practices into consideration, there are several options that can be used for fastening cladding to steel framing. These include nails (with wood substrate), screws, and pins.

Generally, nails could be acceptable if some type of wood-based surface were used over or under the exterior insulation. OSB sheathing and wood furring strips should be investigated.

Screws are generally the preferred method for attaching cladding or furring strips to steel framed walls. In addition to Phillips-head screws, screws come with square-drive and star-drive heads that allow higher torque driving without stripping the head. Numerous mechanical fastener companies produce screws that meet these requirements and are long enough for installation purposes.

Pneumatic pin fasteners have the potential to speed installation for a variety of siding materials over continuous insulation. One current setback for pins is the limitation of the pneumatic fasteners themselves. Currently the most common maximum length that a framing gun can fire is up to 3 ½". Longer pins would need to be available, or this fastener type would be limited to assemblies with at most 2" of exterior continuous insulation.

Summary

Codes have historically left much of the prescriptive requirements for siding attachment to manufacturers' installation recommendations. Only recently have codes begun to question whether all applicable loads were being addressed. Further, the recommendations of manufacturers and code requirements have developed over the years based mostly on experience. These recommendations were never intended to apply to assemblies with thick layers of exterior continuous insulation.

The steel framing industry (as well as other industries) is in an interesting position. Many of the current prescriptive fastening requirements or methods could be judged as insufficient if subjected to a thorough engineering load analysis. At the same time, the practices in use today have been proven to work based on field application. Thus, updating current manufacturer fastener requirements for cladding installed on top of up to 1" of exterior continuous insulation is not necessary. However, the addition of greater than 1" of exterior continuous insulation typically takes designers outside the scope of traditional or accepted practice. Because this project seeks to develop fastener prescriptions that are beyond current building practice, engineering analysis and/or test methods must be employed to determine prescriptions that can be projected to satisfy expected seismic, wind, and dead loads, while achieving satisfactory performance (strength of connection and deflection).

In examining the code requirements and related issues, the only "new" load that needs to be considered in developing prescriptive requirements for cladding fasteners is the dead load induced by the weight of the siding/continuous insulation combination (which results in shear loading of the fastener). All other relevant loads on cladding fasteners (i.e. wind and seismic) can currently be determined following the methodologies outlined within codes and standards (e.g. 2009 IBC which references ASCE7-05) or by testing.

The next step in this project will be to identify the options that can be used to connect the siding through exterior continuous insulation and to calculate the adequacy of wood based sheathing to serve as an attachment substrate. A preliminary description of options is in Attachment 2. At the same time, the practical limitations of various options will be evaluated, and a test plan will be developed to confirm the performance of options deemed feasible for steel framing.

References

AF&PA American Forest and Paper Association
AISI American Iron and Steel Institute
ANSI American National Standards Institute
ASCE American Society of Civil Engineers
ASTM American Society for Testing and Materials
CT CertainTeed
ICC International Code Council
JH James Hardie
VSI The Vinyl Siding Institute
WRCLA Western Red Cedar Lumber Association

ASCE. 2005. *ASCE 7-05 Minimum Design Loads for Buildings and Other Structures*.

ANSI/AF&PA. 2005. *ANSI/AF&PA NDS-2005, National Design Specification for Wood Construction*.

AISI 2007a. *AISI S100-07 North American Specification for the Design of Cold-Formed Steel Structural Members*

AISI 2007b. *AISI S200-07 North American Standard for Cold-Formed Steel Structures - General Provisions*

ASTM. 2002. *ASTM E330 - 02 Standard Test Method for Structural Performance of Exterior Windows, Doors, Skylights and Curtain Walls by Uniform Static Air Pressure Difference*.

ASTM. 2006. *ASTM D4756 - 06 Standard Practice for Installation of Rigid Poly(Vinyl Chloride) (PVC) Siding and Soffit*.

ASTM. 2009a. *ASTM A153 / A153M - 09 Standard Specification for Zinc Coating (Hot-Dip) on Iron and Steel Hardware*.

ASTM. 2009b. *ASTM A641 / A641M - 09a Standard Specification for Zinc-Coated (Galvanized) Carbon Steel Wire*.

ASTM. 2009c. *ASTM E330 - 02 Standard Test Method for Structural Performance of Exterior Windows, Doors, Skylights and Curtain Walls by Uniform Static Air Pressure Difference*.

CT. 2008. *Fiber Cement Siding Installation Manual*. Code No. FC017. CertainTeed Corporation, Valley Forge, PA. <http://www.certainteed.com/resources/fc017.pdf>.

CT. 2009. *Vinyl Siding Installation Guide*. Code No. CTS205. CertainTeed Corporation, Valley Forge, PA. <http://www.certainteed.com/resources/CTS205.pdf>.

Environmental StoneWorks. 2008. *Manufactured Stone Veneer Installation Procedures*.
http://www.estoneworks.com/downloads/eStoneworks_InstallationProcedures.pdf

Heckman Building Products, Inc. 2009. *Drill Bolt™ Brick Veneer Shear Anchoring System*.
<http://www.heckmannbuildingprods.com/PDrillBolt.html>.

ICC. 2009a. 2009 International Building Code.

ICC. 2009b. 2009 International Residential Code.

JH. 2008. *HardiePlank Lap Siding Installation Requirements, North*. 91513SLN.
http://www.jameshardie.com/pdf/install/install_plank_north.pdf.

Mediterranean Colors, LLC. - Three Part Specification for Eco Stucco.
www.ecostucco.com/documents/Sustainable.pdf

Owens Corning. 2006. *FOAMULAR® Extruded Polystyrene Insulation, AIResist™ Thermal, Moisture and Air Barrier System FIBERGLAS® Insulation Commercial Steel Stud Framing with Brick Veneer, Product Data Sheet*.
<http://commercial.owenscorning.com/assets/0/144/172/174/d7a8d35c-e330-491c-b876-9ff0c8af5c55.pdf>.

VSI. 2007. *Vinyl Siding Installation Manual*. Washington, D.C.
http://www.vinylsiding.org/publications/0804_VSI_2007Manual.pdf.

WRCLA. 2007. *How to Install Western Red Cedar Siding*.
http://www.wrcla.org/pdf/WRCLA_Installing_Siding.pdf.

Attachments

Attachment 1: Wind and Seismic Zone Maps

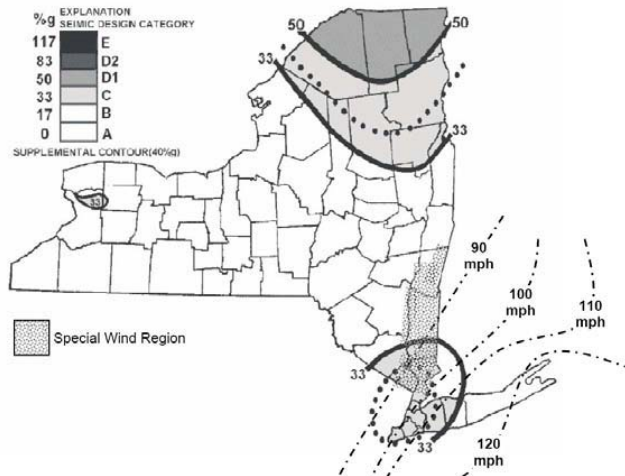

Figure 1: New York State design wind and seismic conditions, adapted from the 2007 Residential Building Code of New York.

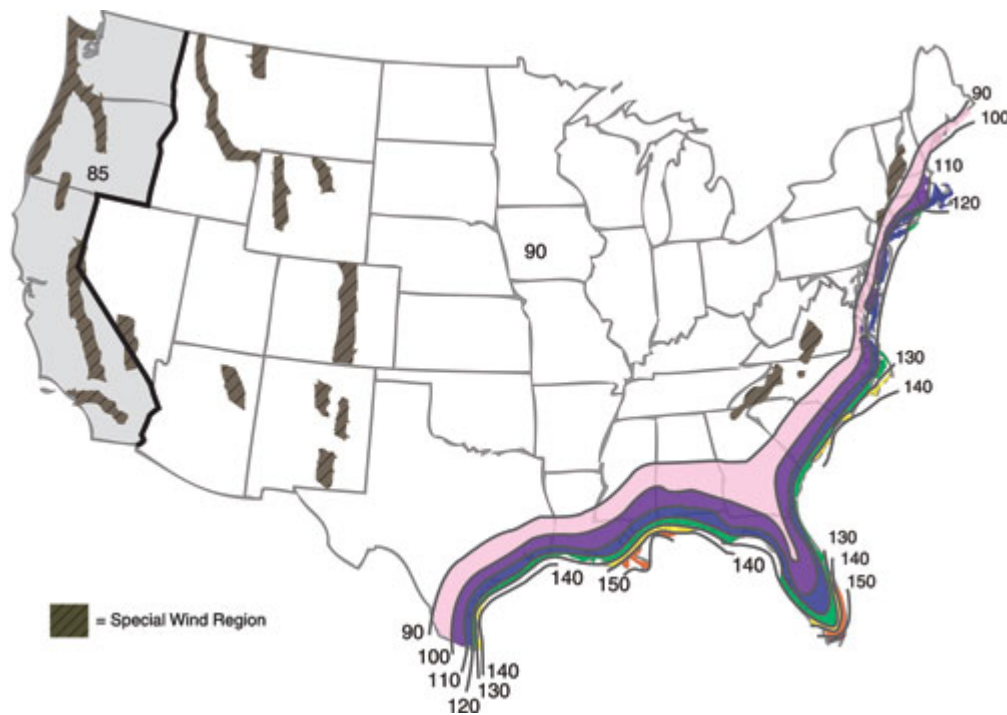
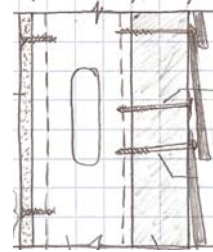

Figure 2: United States Wind Speed Conditions (ASCE 7-05)

Attachment 2: Wall Assembly Options (to be reduced as project proceeds)

Below are a number of wall assembly options to be considered for attaching siding to a steel framed structure. Some preliminary illustrations have been provided for clarity.

1. Continuous insulation attached directly to steel studs, with cladding attached to steel studs through continuous insulation. This will be needed for various commercial and residential wall applications, irrespective of the building/wall bracing methods that may be used on some exterior wall applications. This assembly is especially important for commercial buildings where the building is a concrete structure, and steel framing is used only within curtain walls.



2. Continuous insulation and siding directly attached to structural sheathing (nail base) only and structural sheathing attached to steel framing. In investigating this configuration, typical 7/16" OSB and also 3/4" OSB sheathing will be considered for nail base purposes.

3. 1x or 2x wood furring to steel stud without structural sheathing. Use of wood furring is a basic option that avoids many variables for siding attachment, as siding attachments to wood members are well known and developed. Data for this configuration could also be conservatively applied to walls with structural sheathing under the continuous insulation.

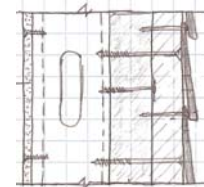

4. 1x or 2x wood furring to steel stud with structural sheathing. Having fastener penetration in structural sheathing and steel studs may tend to stiffen and strengthen the fastener so that it can cantilever through thicker foam and hold greater siding weight under shear. This may improve design values and limit fastener sizes and spacing requirements relative to option #3 above.
5. 1x or 2x wood furring to structural sheathing/nail base only. Allows furring to be attached anywhere and blindly to the wall, except steel studs may interfere with wood furring fastener installation. In this approach furring can be spaced at 16"oc (as limited by many siding options) whereas steel studs can be spaced at 24"oc. This would allow greater flexibility, but again the thickness of structural sheathing may need to be increased for adequate nail base.
6. Metal furring hat channels attached back to steel studs through continuous insulation, similar to the use of 1x or 2x wood furring. Benefits associated with the use of hat channels versus wood furring are lighter weight and longer lengths. The hat channels can also be attached to horizontal Z-channels allowing for ease of installation. However, use of Z-channels creates a thermal break through the continuous insulation. The Z-shape furring must be fastened to the framing or sheathing and extend through the foam sheathing in a continuous fashion for the length of the Z-shape furring member. Also, the furring penetration through the foam sheathing layer will require placement of a water-resistive barrier (WRB) behind the Z-shape furring on a separate sheathing layer installed in addition to the foam sheathing layer.

TASK 2

CONSTRUCTABILITY ISSUES

Introduction

Each time a building code or building technique is modified, builders have to adapt and overcome any construction issues that may arise. Often, solutions go through several stages until an acceptable and efficient solution is identified. An example of this process was illustrated when building codes began to require more insulation within the wall cavities. Builders adapted by increasing the wall width to 2x6 instead of 2x4 the norm at the time. Consequently, window and door jambs had to be adjusted in order to keep them flush with the finished wall. On-site window/door jamb extensions had to be built until the window and door manufacturers started offering extended jambs from the factory.

The use of rigid foam insulation of up to one inch does not generally create significant concerns for most buildings. However the use of more than 1 inch of foam (2 inches, 3 inches, and 4 inches of rigid foam and beyond) can lead to a number of constructability issues that need to be addressed during the early stages of the design process of the home and during construction. These issues are important to address so that builders understand proper application techniques of cladding and other outer shell items.



Image 2.1: Home covered with 2 inches of rigid foam in New York

Process

Anticipating all of the constructability issues while installing different types of cladding (vinyl, fiber cement, wood lap, brick/stone veneer, solid brick, and stucco) over continuous insulation up to four inches thick can be difficult. Newport Ventures conducted an assessment of the proposed solutions identified in Task 1 of this project to identify constructability problems and solutions. During the course of this investigation Newport conducted a thorough review of manufacturer literature, drew upon their own professional and technical knowledge, spoke with persons in the carpentry, electrical, plumbing and HVAC trades, and visited numerous construction sites to create a list of constructability issues. Much of the experience with thicker than one inch of foam insulation on exterior walls is limited to lower rise buildings such as housing. Thus, although there is a slight bias toward housing construction practices in the findings of this task, much of it can be extrapolated to larger buildings.

As part of the assessment, Newport also conducted a hands-on session with contractors to discuss issues related to the use of thicker rigid foam applications on the exterior of a steel framed wall. The session focused on extended length fasteners, other fastening needs, and the interaction of the foam with different structural features and external claddings.

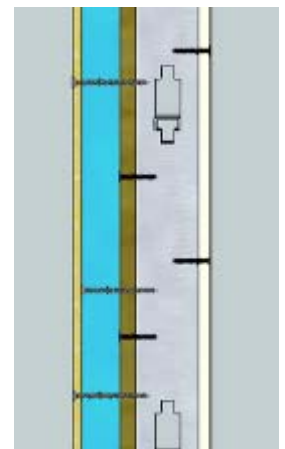

Image 2.2: Sectional view of a steel framed wall with continuous rigid foam

Contractor Session

The purpose of the contractor's discussion group was to examine constructability issues that may arise with the attachment of up to 4 inches of rigid foam insulation to the exterior side of a steel framed wall and test the theories and solutions identified in the first stages of research. The meeting occurred January 6, 2010 at Newport Ventures Schenectady, NY office complex. The discussion outline for the session is contained in Appendix A.

Four contractors were invited to provide insight and to gain useful feedback on issues that may arise during field applications of continuous installation. The group consisted of a carpenter, electrician, plumber and an HVAC contractor.

As an aid to discussion, Newport constructed a full sized model of a steel framed exterior wall, which had sections 8 feet in length and 8 feet tall and incorporated both inside and outside exterior corners, allowing room for fastening a variety of trim and siding materials. Also included in the model were a doorway and a window opening although actual windows and doors were not installed.



Image 2.1: Full Size Model

The model process provided a meaningful hands-on way to demonstrate different assembly aspects as they relate to on the job issues that may occur with the use of added continuous rigid foam insulation. It allowed for multiple assembly options with the ability to view the inside of the wall cavity for viewing screw penetration and other aspects of the construction.

Results

The main concern addressed by the contractors is that some of the longer fasteners are not available from local suppliers. This can be avoided early on by identifying and ordering the proper fasteners directly from manufacturers and having the fasteners delivered directly to the jobsite.

Another significant issue that was mentioned by the contractors was the ability to maintain production speed as the structure is being built. Changes to the home's outer shell such as added rigid insulation depth can slow this process. Nail guns are used to speed installation of some cladding materials but the fasteners are limited to 3 1/2" in length. This all but eliminates the use of air guns once foam board thickness surpasses the fastener reach point. What may have required one carpenter to install siding may require a second one. If installing insulation after the wall is already installed, one installer needs two hands to hold a longer screw on to the tip of their screw gun, while

the other person holds the siding in place. Unlike some new building techniques, contractors did not anticipate a decrease in this added labor after overcoming any learning curve. Thicker foam panels will require more than one person for the foreseeable future and accounted for in the total project costs. Follow up questions and answers were obtained from phone and email communications as contractors were asked to think more about attaching different siding types, fiber cement, vinyl, stucco, etc.

Along with prior research findings, the information gathered from the contractors was used to identify specific issue as shown in Table 2.1. The tables offer suggested solutions that account for structural and performance concerns, reduce site construction time, and minimize the necessity of impromptu solutions that may be different from builder to builder. A discussion of each issue is provided in the sections following the table.

Table 2.1 – Constructability issues

<i>Constructability Issues</i>	<i>Concerns</i>	<i>Solution #1</i>	<i>Solution #2</i>	<i>Solution #3</i>
Blind connection of fasteners to steel studs	Fasteners securing to the steel studs.	Transfer layout directly from wall framing to each attachment of rigid foam insulation.	Snap vertical chalk lines at each stud location after foam has been installed.	
Outside/Inside Corners	Fastening trim detail to the building.	½” or ¾” plywood ripped to proper width depending on the thickness of the foam used.	Aluminum flat stock bent 90 degrees screw to metal studs	
Windows/Door Jambs	Fastening windows/doors to the exterior of building.	Solid Lumber or plywood box attached back to wall framing (bucks). Openings should be wrapped with adhesive flashing.	Extended widow and door jambs to fit additional width of wall opening.	Metal Strapping/Brick Ties
Below Grade Wall transition to Above Grade Wall	Exposed rigid foam on the exterior of the building. Break in thermal envelope.	Cap rigid foam with metal flashing. Metal flashing can be attached to the front of the foam before siding is attached and attached back directly to the foundation.	Continue rigid foam insulation from AGW to BGW flush.	

Constructability Issues	Concerns	Solution #1	Solution #2	Solution #3
Gable End Transition	Finished appearance/aesthetics.	Continue rigid foam full length.	Frame out gable end wall with studs to flush up with rigid foam.	
Roof/Soffit/Wall Transition	Finished appearance/aesthetics. Break in thermal envelope.	Adjust preliminary drawings to reflect added rigid foam insulation.	Raised Heel Truss to allow for insulation to meet attic insulation levels and for the attic insulation to extend flush with rigid foam on the wall.	Accept reduced overhang as is.
Decks	Solid fastening of deck to the house.	Bolt solid wood blocking back to exterior wall. Avoid a built up solid ledger as this would create a thermal break.	Provide footings for deck along the house to keep deck separate from house.	
Peripherals				
Dryer vent, hose bib, direct vent appliances, doorbell, flower box, brackets, etc. (Not seen as major issues)	Solid attachment	Longer fastening screws to attach item to sheathing or stud. J-Blocks can be installed as well with a longer fastener.	Add in solid blocking at the location of the peripheral item.	

Blind connection of fasteners to steel studs

The first issue that arises from covering up the sheathing on a home is the visual loss of the stud layout. No longer can the carpenter see where the studs are located on the wall. This is important as many cladding manufacturer warranties require their product to be fastened directly to the framing. The visual loss can be overcome by transferring marks directly to the foam board as it is applied sequentially up the face of the wall. Another option is measuring over the rigid foam and placing marks to later snap a chalk line. Both options increase installation time but will ensure that the fasteners penetrate into the steel stud.

Outside/Inside Corners

Fastening foam and siding at the corners of a building can become an issue with the added thickness of rigid foam. On outside corners, the closest stud will be as much as four inches off of the corner, leaving no suitable way to secure a fastener. Furring strips, plywood, OSB, metal corners, or other suitable material can be applied over the corners to create a permanent attachment surface. The materials must be wide enough to allow them to be secured to the closest stud. Metal may prove to be the most practical material because it is very thin compared to wood and other materials, thus eliminating a potential problem of a change in the surface at corners. With thicker materials, some builders have also used wood or plywood on inside corners (see photo below) to eliminate the change in surface. Intermediate furring between the inside and outside corners may also be necessary if using thick corner materials.

On inside corners, the foam on an adjacent section of wall must stop short of the end of the wall to allow for corner studs in the intersecting walls to be attached. This is especially important to account for if the foam is added before the walls are tilted up into place. Further, an extra stud will need to be placed in the wall cavity 4 to 6 inches from the inside corner to provide a surface for attaching the foam and siding.



Image 2.3 – Siding plywood at inside (left) and outside (right) corners



Window/Door Openings

The exterior wall will be much thicker than a conventional wall if thick layers of rigid foam board are used. This creates a deeper than normal window and door opening.

The flange mounted on most windows is used to connect to a solid surface such as a stud. It cannot be secured to foam. Additional framing such as a wider stud can be used to box out openings and provide a solid surface for attaching windows and doors. This option will require extended window and door jambs to compensate for the additional wall thickness, or drywall returns on the inside. Another option is to mount the windows to the wall before the rigid foam is added. This will create a recessed window pocket that will need to be flashed and sealed properly to prevent any leaks. One drawback to this option is recessed windows are not a common look for many buildings. This option also changes the traditional sequence of construction. This may be particularly difficult for panelized construction if the panel manufacturer is charged with providing panels already sheathed with foam.



Image 2.4: Extension Jambs attached directly to a window

Foundation Wall transition to Above Grade Wall:

The transition from the foundation to the above grade wall is an area where the additional rigid foam board will need to be detailed. This detail creates an exposed area at the bottom of the wall that should be covered to protect the foam.

One option would be to cap the foam at the bottom of the wall with metal flashing. This metal flashing can be secured to the foundation and the exterior wall by using common fasteners.

Another option is to continue the rigid foam down to the ground level to create a smooth transition from the above grade wall to the foundation. The advantage to this method is creating an insulated foundation wall from the outside. It will, however, require a parge/stucco coating to protect the foam from sudden impacts such as a weed whacker or lawn mower. A disadvantage of this option is that it conceals termite tunnels.



Image2.5: Capped foam edge at the bottom of a wall with metal flashing

Gable End Transition

The gable ends of a house with an unconditioned attic space do not require the rigid foam board that would be in place on the rest of the building. This however would not create a smooth transition between conditioned space and unconditioned space on the exterior wall. One option to alleviate this concern is to run the rigid foam board completely to the roof line. Fiberboard or other alternative sheathing materials may be less expensive than foam for the gable end section of the wall.

A second option is to build the gable end so that the OSB or other sheathing lines up with the foam sheathing to eliminate any transition. This option will likely be more practical with thinner foam insulation. The gable end can't be offset more than an inch or two or there will not be a way to attach it to the wall below. It may be possible to fur out the gable end as a third alternative.



Image 2.6: Rigid foam applied to gable end on the ground than lifted into place with a crane



Image 2.7: Rigid foam continued over the gable end

Roof/Soffit/Wall transition

The addition of rigid foam reduces the roof overhang and the soffit area. If it is important to maintain specific dimensions for aesthetic reasons, the length of the overhang should be increased during the design of the building.

Decks

Decks are often attached through a continuous ledger board adhered to the structural frame of the building. With the introduction of foam, it is important to maintain the structural integrity of the ledger board's connection to the wall. If the ledger is to be placed over the foam, the fastening details should be designed by a qualified professional and approved by the code official. Another option is to cut the foam out, attach the ledger board to the structure, and then install foam between the bays of the joists of the deck. This option will minimize the surface area that can produce thermal bridging and allow the continued use of the traditional ledger board method. A third option for low-rise buildings is to build the deck as a stand-alone structure not secured to the house at all. There are trade-offs to each of these options, including significant extra costs for some.

Peripherals

Additional items that are not major concerns but that should receive attention are dryer vents, hose bibs, direct vent appliance, doorbells, flower box, brackets, etc. Blocking, longer fasteners, or extensions will need to be used for the peripheral items to be properly attached to exterior walls

The solutions for attaching siding identified in Task 1 include direct attachment to studs through foam, attachment through foam to structural sheathing, or connecting siding to steel hat channels or wood furring strips installed over the foam. It is important to note that the hat channel or furring strip approach solves at least a couple of the issues identified in Table 2.1. For example, if a hat channel is used, it can be extended to the end of the wall at outside corners to provide a fastening surface for siding without the need for a special corner. A hat channel can also provide a surface for attaching periphery items to walls with thick foam insulation.

Coordination with Task 3 Findings

Task 3 of this project has as its primary objective the evaluation of specific fastener types for use with the proposed solutions for attaching siding when foam up to 4 inches thick is used on exterior walls. This includes development of specific language acceptable for building codes.

Task 2 and 3 are somewhat inter-related in that laboratory testing and analysis from Task 3 revealed several constructability issues. These are provided as follows:

Overall, the Task 3 findings confirm that the direct attachment to studs and the hat channel/furring method offer technically justified solutions. Some specific findings related to these solutions are as follows:

1. It is important to order specialty screws (i.e., extra long length) for siding-to-steel connections well ahead of time in the construction schedule (even stock up if you have more than one construction project planned). The laboratory had trouble finding fasteners of adequate length for the four- inch thick foam assemblies. The five-inch fasteners that were originally ordered were long enough but the threaded section of the screw was not. The lab was eventually able to find a bugle head screw that did have the right length with a threaded length long enough to engage the studs. Although these screws were adequate for the testing, they may present problems for finishes or could damage hat channels when installed. Due to time constraints when waiting for the screws, the testing did proceed with the original screws on the wood furring application. However, the screws had to be countersunk into the wood effectively reducing its thickness to 3/8” at the fastener head location. This resulted in more conservative fastener requirements than if the thicker 3/4 furring had been used for the four-inch foam assemblies. For siding connections to steel framing and to avoid the need for specially designed or proprietary connection solutions, it may be that assemblies with up to 3 to 3-1/2 inches of foam represent a practical limit on exterior continuous insulation thickness until appropriate “off-the-shelf” fasteners become more widely available.
2. The torque setting on the screw driver needs to be set to ensure that connected parts are adequately compressed together without any gaps, yet also without over-tightening causing damage to siding or furring materials.
3. Where possible and depending on the type of siding used, use wing-tipped, self-drilling/tapping screws to prevent the fastener threads from engaging in the connected parts and causing separation of the foam sheathing and furring/siding from the steel framing.

More research is needed to further assess the advantages and disadvantages of attachment directly into OSB or other structural sheathing. It is unlikely that we will be able to rely on connection to wood sheathing materials to support heavy siding materials (e.g., greater than 3 psf) with an intervening layer of foam sheathing of substantial thickness. Based on limited testing these connections appear to be subject to much greater creep (long term movement) than with direct connection to steel framing. Also, when using fasteners of greater diameter than 0.120", there appears to be an increasing loss of withdrawal capacity relative to "normal" withdrawal capacity of the fastener (due to break-out of wood fiber/chips on the back side of typical thickness sheathing). For the time being, the language for code adoption developed under Task 3 will not include the solutions that include direct attachment to sheathing.

Task 2 Appendix: Discussion Guide from the Contractor Session.

1. Introductions and ground rules (2 minutes)
 - a. Introductions – Name, company, what you do
 - b. Ground rules – Don't be afraid to give your opinion, work for equal speaking opportunity for everyone
2. Explanation of the overall issue – (2 minutes on the issue, the siding types, the wall, etc)
3. Brainstorming Session (general guidance of average of 5 minutes an issue)
 - a. Ask participants what immediate issues come to mind when trying to attach the following sidings over up to 4 inches of foam insulation – vinyl siding, fiber cement, wood lap, stone/brick veneer, anchored stone/brick, and stucco.
 - b. For each issue, ask for suggestions of possible solutions
 - c. For any issues already identified in our list, after discussing their solutions, ask: “what do you think of [solution x]?” Will it work? Is the issue solved or is it still a problem even if that solution helps.
 - d. Ask if any suggested solutions could be combined to come up with a complete solution or are they standalone solutions.
4. After Brainstorming session, continue through the list of identified issues following the same format as above. (again, general guidance of 5 minutes an issue) See Example Questions Below:
 - a. How would you handle the fastening trim detail for siding on the outside corner?
 - i. Would ½” or ¾” plywood ripped to the proper width work? How about aluminum flat stock bent 90 degrees and screwed to the stud?
5. Ask if any additional issues have come to mind after going through that list.

TASK 3

DEVELOPMENT OF PRESCRIPTIVE CODE REQUIREMENTS

Introduction

Recent and ongoing changes in model energy codes to improve energy efficiency of buildings have created an urgent need to address technological gaps in methods of attaching cladding to steel framed wall assemblies when various thicknesses of continuous insulation (foam sheathing) are applied to the wall assembly. Solutions to address this need are currently under consideration for wood frame wall assemblies in the U.S. model building code development process. Similar solutions also are needed for cold-formed steel framed wall assemblies.

Model building codes and standards are expected to require a much more extensive use of foam sheathing on steel framed wall assemblies in the near future. The required thickness of foam sheathing may vary from 1” to 4” depending on the type of foam sheathing used and the climate, among other things. Obviously, such requirements necessitate rational and practical solutions for attachment of cladding to walls through a potentially thick layer of foam sheathing. These solutions must also provide safe and serviceable installations of cladding and continuous insulation.

The purpose of Task 3 of this project was to identify prescriptive requirements for fasteners in attaching cladding to steel framing. Multiple scenarios were to be evaluated, including synthetic stucco, fiber-cement, wood, and vinyl siding applied over various thicknesses of foam. The outcome is a prescriptive-based set of requirements for fastening siding that could be incorporated into building codes.

The activities necessary to address the objectives were multifaceted involving several research and development steps as follows:

1. Consideration of building code requirements related to cladding connections as identified in Task 1,
2. Development of viable connection strategies in coordination with constructability issues identified in Task 2,
3. Assessment of methods for developing fastener requirements based on accepted engineering practices. Based on early findings of this task, it was expanded to include preparation of a test plan to resolve technological gaps in understanding and predicting the performance of cladding connections to steel framing with an intervening layer of continuous insulation
4. Execution of the test plan with adjustments to respond opportunistically as “real-time” findings revealed new information,
5. Analysis of test results to develop a rational means of predicting connection performance for a variety of conditions or cladding assembly variables addressed by the test plan, including coordination with research and testing and analysis methods being developed by others,
6. Preparation of building code proposals to implement and integrate findings within the context of current model building code provisions for siding attachment and foam sheathing.

This Task 3 report documents the outcome of the above activities. First, a Background section reviews the various siding connection strategies considered for the Task 3 effort. Second, the Technical Approach section presents an overview of research and testing plans (see Appendix A). Next, the Summary of Testing Results summarizes and discusses test results based on a separate laboratory report (PEI, 2010a) included as Appendix B. The Analysis of Results section discloses

the evaluation of test data (see also Appendix C) to derive or confirm rationalized design methodologies for calculating cladding connection performance when the fastener must span through an intervening layer of foam sheathing. This design methodology together with building code performance requirements was used to derive a proposal for building codes included in Appendix D. Finally, conclusions and recommendations are presented.

Background

Among various possibilities identified in Task 1, and in consideration of constructability issues identified in Task 2, four cladding connection strategies were identified for further consideration in the Task 3 effort. These strategies are shown in Figure 3.1 and are described as follows:

1. Attachment of cladding to a sheathing fastener base (Option #1) located behind the foam sheathing by way of a direct siding condition (Means (a)) or by way of a steel or wood furring member (Means (b)).
2. Attachment of cladding to a framing member (Option #2), again by way of a direct siding connection (Means (a)) or by way of a steel or wood furring member (Means (b)).

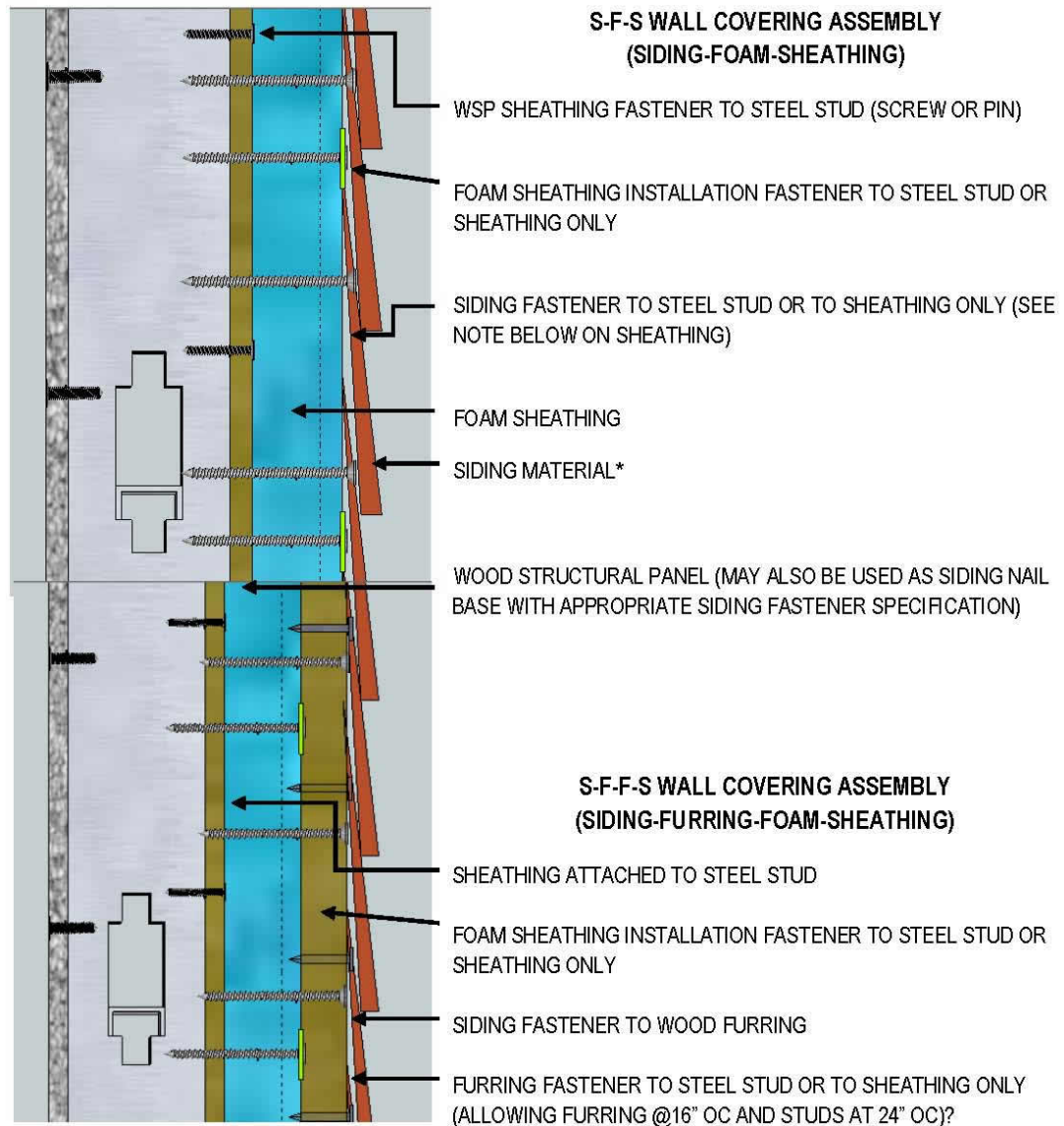

- ← WOOD FURRING (SEE NOTE ON DETAIL B)
- FOAM SHEATHING
- ⌊ WOOD STRUCTURAL PANEL (SEE NOTE ON DETAIL C)
- ⌊ STEEL STUD

Figure 3.1. Siding attachment strategies.

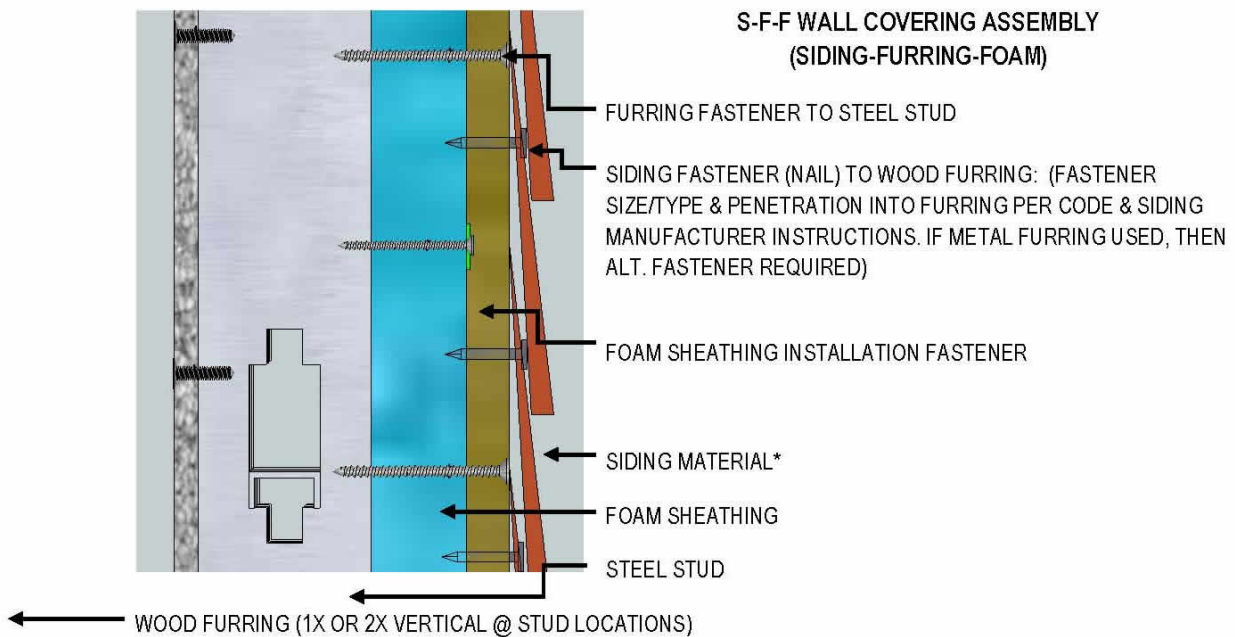
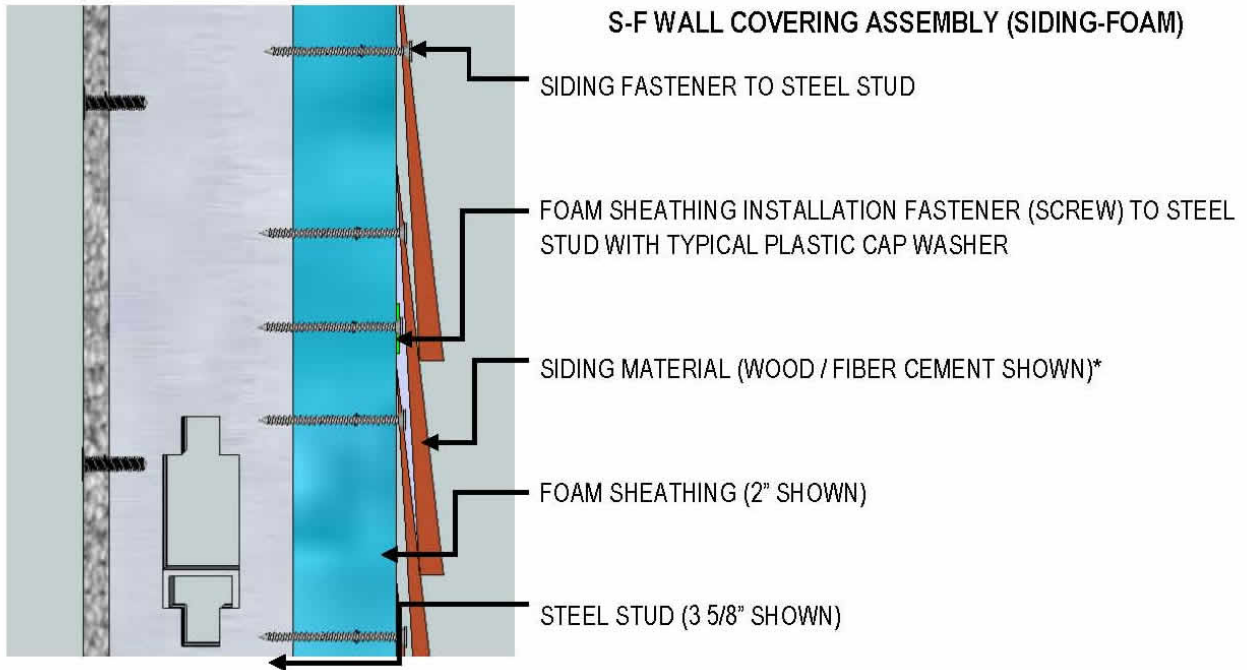

Figure 3.1. Siding attachment strategies (continued).

The Task 3 effort addresses structural requirements for the four siding attachment strategies shown in Figure 3.1 by testing and analysis to ensure capability to:

1. adequately support siding dead load (i.e., transfer shear forces from siding weight through a thickness of foam sheathing into the structural framing members or sheathing), and
2. resist wind pressure and seismic forces¹ (i.e., transfer out-of-plane forces from wind pressure or seismic accelerations acting on siding through connections and into the structural framing members or sheathing).

While the details in Figure 3.1 indicate a lapped type of siding, various types of sidings may be applied with identification of a siding fastener with appropriate diameter and head shape/size compatible with the siding manufacturer's installation instructions and building code requirements. Where wood furring or steel hat channels are used, typical siding fasteners may be applied and this research focuses mainly on how to attach the furring or hat channel over foam sheathing to support the siding. For direct cladding attachment over foam sheathing to steel framing using self-drilling tapping screws, availability of "extra-long" fasteners was faced with some supply problems caused by low demand in current market conditions. However, fasteners (manufactured by Grabber) were found to allow up to 4 inches of foam sheathing thickness with the above strategies. Other fasteners for steel and wood connections were identified through common distributors such as Fastenal. For direct attachment to a base sheathing such as OSB, various fasteners may be used to make this connection (i.e., screws or nails) which are generally available in a reasonable variety of non-standard (extra-long) lengths. For example, a 6-inch-long "foundry nail" of 0.135-inch diameter was readily available (manufactured by Maze Nails). However, this research identified some concern with creep (long-term movement or settling of the connection) with connections directly to sheathing. This concern is addressed later based on results of testing.

Finally, cladding materials designed to be separately supported (such as brick veneer) are not addressed in this project. These materials may be attached to continuously insulated walls without concern for the fastening needing to support the weight of the cladding. Thus, the connection need only resist the out-of-plane forces from wind or seismic actions. These cladding connection solutions are readily available with or without continuous insulation on wall assemblies and can be designed with existing technology.

Technical Approach

With completion of the background investigation as described in the previous section, a comprehensive research plan was developed to provide a means of characterizing and predicting the performance of connections similar to those shown in Figure 3.1. Existing engineering knowledge was used when available to predict connection capacities and a test plan was developed to verify the ability to make accurate predictions of actual performance. Existing knowledge regarding this type of connection (with a gap between the connect parts occupied by a material like foam insulation) was found to be limited to a wood-to-wood or steel-to-wood connection design theory, known as the NDS or European Yield Theory for wood connections resisting shear loads (AFPA/NDS, 2005;

¹ Seismic forces are mainly a concern for heavy siding materials.

USDA/FPL, 1986(a)). This design theory has the capability of estimating connection shear strength when connections have a gap, or, an intervening layer of foam sheathing (AFPA/TR-12, 1999). In fact, the “gap parameter” as used with this design theory was developed by the U.S.D.A. Forest Products Laboratory based on limited testing of wood-to-wood connections with an intervening layer of foam sheathing up to 1” thick (USDA/FPL, 1986(b)). The method has also been generalized for use with a variety of other materials (such as concrete or steel), but only for specific configurations for connections to wood members (AFPA/TR-12, 1999). Unfortunately, a similar mechanics-based design theory for steel-to-steel and wood-to-steel connections (or various other materials to steel) does not exist for connections with or without a gap between the connected parts. Instead, equations used for the design of these types of connections are aimed at connection of steel parts only and rely on empirical relations and the assumption of no gap in the connection (AISI S100, 2007). Thus, there is no existing rational means of predicting the shear-resistance performance or designing these types of connections with a gap or, more specifically, a layer of foam sheathing between the connected parts.

While strength of connection may be considered a primary concern in predicting connection performance, other matters were considered in relation to acceptable performance. For example, siding connections must support the weight of siding without excessive deflection. Thus, connection strength should be limited to ensure not only safety but also adequate deflection performance. In addition to deflection caused by immediate load application, wood connections and members as well as plastics, such as foam, exhibit a plastic behavior and plastics “creep” over time. Thus, creep effects were additionally considered in the Task 3 effort. No prior research was identified which addressed these concerns for the types of connections considered in this study.

Based on the connection options identified for consideration in Task 3 (see Figure 3.1), the technical approach was aimed at verifying appropriate use of the NDS Yield Theory for connections with foam sheathing thicknesses up to 4 inches thick and for wood-based substrates (sheathing) as thin as 7/16-inch-thick (i.e., typical oriented strand board (OSB) sheathing). For these same connections, the withdrawal resistance of fasteners in thin wood-based sheathing was considered technically important as this application is beyond the limitations of existing codified design knowledge and, therefore, also is in need of verification. Also, the technical approach was aimed at developing a means of predicting connection performance for steel-to-steel (i.e., hat channel to steel stud) and wood-to-steel (i.e., 1x wood furring or siding to steel stud) connections with an intervening gap (layer of foam sheathing). Finally, creep effects under sustained loading also were considered in the technical approach.

To implement the above-described technical objectives, a testing plan was developed and is included in Appendix A. The reader is referred to Appendix A for details of the test plan and to the laboratory test report (PEI, 2010a) included as Appendix B for detailed results from the tests conducted in accordance with the test plan. Originally, the test plan included individual fastener tests of screws in steel framing in the interest of attempting to develop a connection design theory similar to that of the NDS Yield Theory. However, during the course of testing it was determined that assembly tests provided a more valuable use of limited resources and provided a more realistic basis for empirically understanding connection performance within the immediate objectives of the Task 3 effort.

Summary of Testing Results

This section presents a summary of the findings from the testing effort and is based on more detailed information and data found in the laboratory test report (PEI, 2010a) included as Appendix B. For a detailed accounting of the test results, including test methods, load deflection plots, various material properties (i.e., wood density, steel tensile strength, fastener bending yield, foam density, etc.), and other related information, refer to Appendix B. An image of a typical connection shear test set-up is shown in Figure 3.2.



Figure 3.2. Typical shear test set-up (PEI, 2010a).

Cladding Connection Assembly Shear Tests – Table 3.1 summarizes shear test results for the tests conducted with steel furring (33mil hat channel), 1x wood furring, and cladding connections to steel framing (C-shaped studs). Typical cladding connections were emulated by using a wood furring thickness reduced to 3/8-inch-thick at the fastener locations by use of a 2-inch-diameter boring bit. Shear tests simulate the lateral force and displacement that a cladding connection would experience due to the weight of the supported cladding material. Table 3.2 provides a summary of shear test results for steel furring (33 mil hat channel) and wood furring connections to 7/16-inch-thick and 3/4-inch-thick OSB sheathing used as a fastening base. Because the connection was to a wood-based sheathing material, nails and screws were used for steel furring (with pre-drilled holes) and wood furring connections. In all these tests, foam sheathing thicknesses of 1”, 2”, and 4” were included. A few tests also included no foam sheathing between the connected parts and these tests formed a baseline or control group for comparison of existing connection design theory based on the absence of a gap (no foam sheathing) in the connection. Analysis of these results is addressed in the next section. Two typical shear load-deflection plots are shown in Figure 3.3.

TABLE 3.1 – Cladding Connections to Steel Framing

33 mil steel hat channel to steel stud shear tests (steel-to-steel connections with and without gap):									
Test ID	Description	gap (foam) inches	Max Load	Defl. @	Average Load (lbs) per Screw at Deflections:				Failure Mode
			per Screw (lbs)	Max. Load (in.)	0.015"	0.125"	0.250"	0.375"	
3.1-(b1)	33mil hat, 1"EPS, 33mil stud, (2) #8x2-3/8" screws w/1/4" washer	1	242.5	0.653	21	40.5	73.5	125.5	II (rotation)
3.1-(b2)	33mil hat, 4"EPS, 54mil stud, (2) #10x5" screws w/1/4" washer	4	557.5	2.079	68	84.5	102	120.5	II (rotation)
3.1-(b3)	33mil hat, no EPS, 33mil stud, (2) #8x2-3/8" screws w/1/4" washer	0	624	0.146	260	594.5	624	624	Im (bearing)
3.1-(b4)	33mil hat, 2"EPS, 33mil stud, (2) #10x3.5" screws w/1/4" washer	2	194.5	0.875	30.5	43.5	60.5	83.5	II (rotation)
3.1-(b5)	33mil hat, 2"EPS, 54mil stud, (2) #10x3.5" screws w/1/4" washer	2	964	1.619	69	96	124.5	157	Im (bearing)

wood furring to steel stud shear tests (wood-to-steel connections with and without gap):									
Test ID	Description	gap (foam) inches	Max Load	Defl. @	Average Load (lbs) per Screw at Deflections:				Failure Mode
			per Screw (lbs)	Max. Load (in.)	0.015"	0.125"	0.250"	0.375"	
3.2-(b1-1)	3/4" wood furring, 1"EPS, 33mil stud, (2) #8 screws	1	175	0.387	45	98.5	137	168.5	IIIIm
3.2-(b1-3)	3/8" wood furring, 1"EPS, 33mil stud, (2) #8 screws	1	220.5	0.661	41	73.5	103.5	140.5	II (rotation)
3.2-(b1-4)	3/4" wood furring, no EPS, 33mil stud, (2) #8 screws	0	437	0.501	162.5	315	164.5	412	Im (bearing)
3.2-(b1-5)	3/4" wood furring, 2"EPS, 33mil stud, (2) #10 screws	2	205	0.867	33.5	54.5	78.5	98.5	IIIIm
3.2-(b2-4)	3/4" wood furring, 2"EPS, 54mil stud, (2) #10 screws	2	411.5	1.599	57	94.5	127.5	159.5	II (rotation)
3.2-(b2-3)	3/8" wood furring, 4"EPS, 54mil stud, (2) #10 screws	4	286.5	1.442	62.5	79	96.5	114.5	II (rotation)

Key to failure modes reported in Tables 3.1 to 3.4 based on AFPA/NDS (2005)	
Mode Im	Bearing failure in the connected part receiving the fastener point (main member)
Mode II	Rotation of fastener in both connected parts without yielding of the fastener
Mode IIIs	Rotation of fastener in connected part at the fastener head (side member) and bending yield of fastener at interface with connected part receiving the fastener point (main member)
Mode IIIIm	Rotation of fastener in connected part receiving fastener point (main member) and bending yield of fastener at interface with connected part at the fastener head (side member)
Mode IV	Bending yield of fastener at interface with both connected parts (main member as side member)

TABLE 3.2 – Cladding Connections to OSB Sheathing

33 mil steel hat channel to OSB wood structural panel sheathing (steel-to-wood connections with and without gap):									
Test ID	Description	Max Load per Nail (lbs)	Defl. @ Max. Load (in.)	Average Load (lbs) per Nail at Deflections:				Failure Mode	
				0.015"	0.125"	0.250"	0.375"		
3.1-(a1)	33mil hat, 1"EPS, 7/16" OSB, (4) 0.099"x2.25" nails	83	1.295	15.5	37.75	50.25	58.75	IV	
3.1-(a2)	33mil hat, 4"EPS, 23/32" OSB, (4) 0.135" (10g) x 6" nails	192.75	3.372	19.75	37.5	53.5	67	III	
3.1-(a3)	33mil hat, no EPS, 7/16"OSB, (4) 0.099"x2.25" nails	200.5	0.101	81	200.25	200.5	200.5	III	

wood furring to OSB wood structural panel sheathing (wood-to-wood connections with and without gap):									
Test ID	Description	gap (foam) inches	Max Load per Fastener (lbs)	Defl. @ Max. Load (in.)	Average Load (lbs) per Fastener at Deflections:				Failure Mode
					0.015"	0.125"	0.250"	0.375"	
3.2-(a1-1)	3/4" wood furring, 1" EPS, 7/16" OSB, (2) #8 x 3" wood screws	1	192	0.463	68	122	159	182	III
3.2-(a1-3)	3/8" wood furring, 1"EPS, 7/16" OSB, (2) 0.099"x2-1/4" nails	1	72	0.898	24.5	43	53.5	62	III
3.2-(a1-4)	3/4" wood furring, no EPS, 7/16" OSB, (2) #8 x 1.5" wood screws	0	319	0.296	176.5	254.5	311	278	III
3.2-(a2-1)	3/4" wood furring, 4" EPS, 23/32" OSB, (2) 1/4"x6" lags	4	344	1.437	78	109.5	133	156.5	III
3.2-(a2-3)	3/4" wood furring, 4" EPS, 23/32" OSB, (2) 0.135"x6" nails	4	162.5	2.863	41.5	57.5	73	72.5	IV
3.2-(a2-4)	3/4" wood furring, no EPS, 23/32" OSB, (2) 1/4"x2" lags	0	814	0.679	199.5	499	610.5	702.5	II
3.2-(a2-5)	3/4" wood furring, 2" EPS, 23/32" OSB, (2) 1/4"x4" lags	2	418.5	0.988	99	175.5	238	278	II

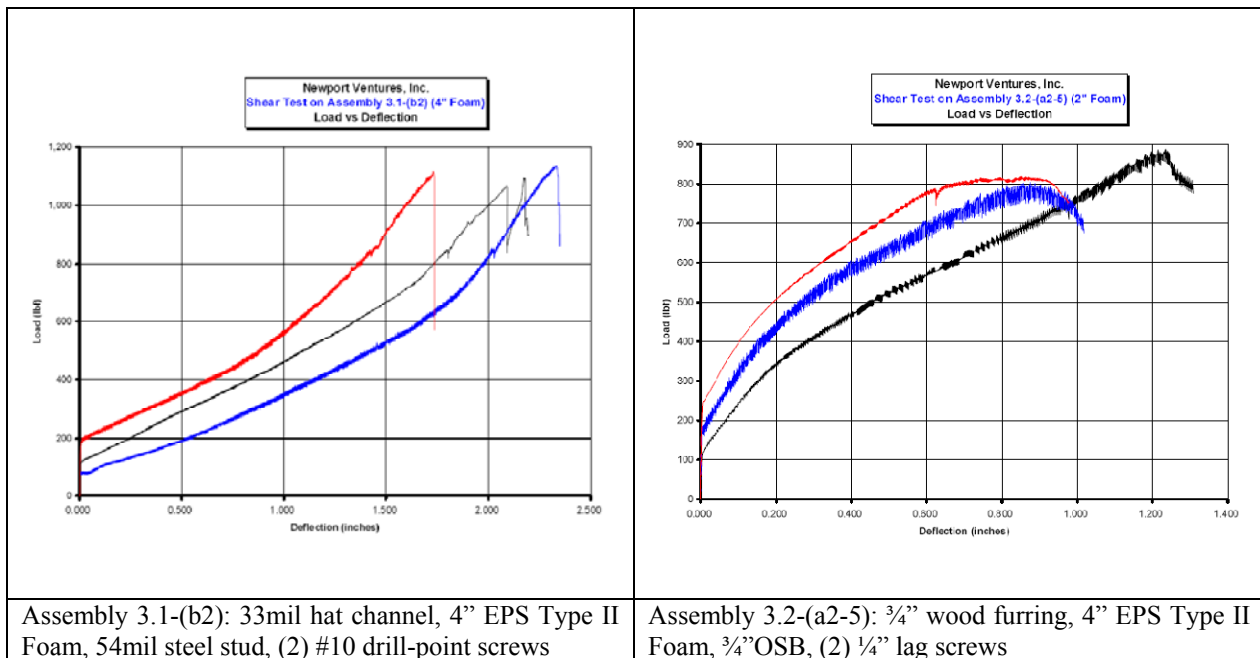

**Figure 3.3. Typical Shear Load-Deflection Plots (PEI, 2010a)
(3 assembly specimens tested for each assembly condition)**

Wood Frame Cladding Connection Baseline Tests – To provide insight into comparable performance of similar connections made to wood studs, additional tests were performed as shown in Table 3.3. These tests together with tests in Table 3.2 provide a basis for evaluating steel-to-wood and wood-to-wood connection performance as predicted by the NDS Yield Theory with application of the aforementioned gap parameter. These tests were also supplemented by a number of similar tests using a wider variety of fasteners and foam thicknesses conducted for the Foam Sheathing Coalition by the same test lab (PEI, 2010b). Results are similar and are shown in Table 3.4.

TABLE 3.3 – Comparative Wood Frame Cladding Connection Tests

<i>wood furring to wood studs (wood-to-wood connections with and without gap):</i>									
Test ID	Description	gap (foam) inches	Max Load	Defl. @	Average Load (lbs) per Fastener at Deflections:				Failure Mode
			per Fastener (lbs)	Max. Load (in.)	0.015"	0.125"	0.250"	0.375"	
3.2-(c1)	3/4" wood furring, 1" EPS, 2x4 wood stud, (2) 0.135"x3.5" nails	1	508	1.753	98	184	236.5	291	IV
3.2-(c2)	3/4" wood furring, 4" EPS, 2x4 wood stud, (2) 1/4"x7" Lags	4	549.5	2.207	64	101	137.5	171.5	IIIs

TABLE 3.4 – Supplemental Wood Frame Cladding Tests (Foam Sheathing Coalition)

<i>FSC TESTING -- wood furring to wood studs (wood-to-wood connections with and without gap):</i>									
Test ID	Description	gap (foam) inches	Max Load	Defl. @	Average Load (lbs) per Fastener at Deflections:				Failure Mode
			per Fastener (lbs)	Max. Load (in.)	0.015"	0.125"	0.250"	0.375"	
a1-screw	3/4" wood furring, (2) #8 wood screw, no foam	0	470	0.67	190	321	377	415	IIIs
a2-screw	3/4" wood furring, (2) #8 wood screw, 1" EPS foam	1	428	1.116	60	119	169	215	IIIs
a3-nail	3/4" wood furring, (2) 16d box (0.135"x3.5") nail, no foam	0	686	1.126	177	362	460	538	IIIs
a4-nail	3/4" wood furring, (2) 16d box (0.135"x3.5") nail, 1" EPS	1	503	1.515	51	128	183	242	IIIIm
a5-nail	3/4" wood furring, (2) 0.135x4" foundry nail, 2" EPS	2	179	1.532	70	100	116	127	IIIIm
a6-nail	3/4" wood furring, (2) 0.135x6" foundry nails, 4" EPS	4	184	1.87	46	71	98	119	IIIIm
a7-lag	3/4" wood furring, (2) 1/4x2" lag screws, no foam	0	933	0.639	170	505	654	784	II
a8-lag	3/4" wood furring, (2) 1/4x3" lag screws, 1" EPS	1	745	1.225	69	168	243	309	IV
a9-lag	3/4" wood furring, (2) 1/4x4" lag screws, 2" EPS	2	649	1.536	91	161	209	248	IIIs
a10-lag	3/4" wood furring, (2) 1/4x6" lag screws, 4" EPS	4	551	2.505	48	78	103	127	IIIs
b1-nail	3/8" wood furring, (2) 8d box (0.113x2.5") nails, no foam	0	221	0.238	98	204	219	221	IIIIm
b2-nail	3/8" wood furring, (2) 8d box (0.113x2.5") nails, 1/2" EPS	0.5	161	0.982	77	120	138	144	IV
b3-nail	3/8" wood furring, (2) 8d box (0.113x2.5") nails, 1" EPS	1	125	1.036	39.5	67	86	94	IIIs
b4-nail	3/8" wood furring, (2) 16d box (0.135x3.5") nails, 1" EPS	1	288	0.73	55	96	125	168	IIIs
b5-nail	3/8" wood furring, (2) 16d (0.135x4") foundry nails, 2" EPS	2	155	1.121	56	77	95	104	IIIs

Cladding Connection Assembly Shear Creep Tests – Table 3.5 reports data on 1-month-long creep tests of selected cladding connection assemblies. These tests show a creep effect for connections to 7/16" and 3/4" OSB sheathing. However, creep effects with connections to steel studs appear negligible.

TABLE 3.5 – Cladding Connection Shear Creep Tests (PEI, 2010a)

<p>Assembly 3.2-(a1-2): 3/4” wood furring, 1” EPS Type II Foam, 7 /16” OSB, (2) #8x3” wood screws (104.3 lbs for 32 days)</p>	<p>Assembly 3.2-(a2-2): 3/4” wood furring, 4” EPS Type II Foam, 3/4” OSB, (2) 1/4” lag screws (126.5 lbs for 32 days)</p>
<p>Assembly 3.2-(b1-2): 3/4” wood furring, 1” EPS Type II Foam, 33mil steel stud, (2) #8 drill-point screws (60 lbs for 21 days)</p>	<p>Assembly 3.2-(b2-2): 3/8” wood furring, 4” EPS Type II Foam, 54mil steel stud, (2) #10 drill-point screws (80 lbs for 27days)</p>

Fastener Withdrawal Tests in OSB Sheathing – Table 3.6 presents results from fastener withdrawal tests in OSB sheathing. These results indicate a decreasing performance trend in comparison with predicted (AF&PA/NDS 2005) withdrawal capacity for nail fasteners with increasing nail diameter and decreasing sheathing thickness. Thus, additional testing should be

conducted to more fully characterize these effects for design purposes. For this reason and for reasons addressed above regarding creep effects, use of OSB sheathing as a means of cladding connection was considered premature and in need of further study before appropriate use within the scope and intent of this study can be determined. The need for this additional work is also relevant to other applications such as siding connections to Structural Insulated Panels (SIP) which use OSB skins on a foam core as a structural wall system (i.e., there is limited framing only at panel splices to which cladding materials can be connected).

TABLE 3.6 – Fastener Withdrawal Tests in OSB

<i>Withdrawal Test Data in OSB Sheathing</i>					
Fastener	OSB Thickness	Pre-drilled		Not Pre-drilled	
		Test W (lbs)-avg	Test W COV	Test W (lbs)-avg	Test W COV
7d box	7/16	37.7	0.09	36.6	0.36
	3/4	64.1	0.11	62.3	0.32
16d box	7/16	84.8	0.17	55.9	0.17
	3/4	174.7	0.24	100	0.23
16d com	7/16	64.3	0.21		
	3/4	114.9	0.12		
#8 wd.sc.	7/16	214.4	0.24		
	3/4	387	0.18		
1/4"lg.sc.	7/16	321.3	0.22		
	3/4	521.2	0.21		

Analysis of Results

Design Performance Criteria – Based on the test results and reviewed precedents for cladding connection performance criteria (Task 1), it was decided that a minimum safety factor of 2.0 (relative to average shear strength) and a maximum short-term load deflection of 0.015-inch would be the basis of applying the results to develop model building code requirements (Appendix D). The 2.0 safety factor was selected from precedents considered most applicable to building envelope component applications (e.g., siding, windows & doors, etc.). Safety factors were found to range from as low as 1.5 (based on a single proof test of a window product as per ASTM E330 or siding wind pressure tests per ASTM D3679, Annex A) to as high as 3.0 (e.g., for structural connections using screws per AISI S100-07 the required safety factor is 3.0). The 0.015-inch deflection limit is a long-standing basis for wood connection design values as used in AFPA/NDS (2005) and this basis for design has a long history of successful performance with materials like wood which demonstrate creep effects under sustained load. Because any connection with an intervening layer of foam may exhibit creep effects or increased tendency for displacement under load (including steel-to-steel connections with an intervening layer of foam), the 0.015-inch deflection criterion provided a logical and consistent basis for design based on current knowledge. In all cases for gapped connections, the 0.015-inch deflection limit controlled design values and thus prediction of connection performance was based on predicting shear load capacity of the connections at a 0.015-inch deflection limit.

For siding connections to steel framing (see Appendix C for analysis of test data), designing to meet a 0.015-inch deflection limit resulted in a safety margin (relative to the tested ultimate capacity) of about 7 on average (range of 4 to 14 for gapped connections). For connections to wood materials (i.e., OSB sheathing or studs), the safety margin relative to the targeted 0.015-inch deflection limit

was about 5.6 on average (range of 3 to 15 for gapped connections). However, an additional safety factor of 1.5 for connections to wood materials was applied to account for potential creep effects (as only evaluated for connections to OSB sheathing, not wood studs, per Table 5). Consequently, the net safety factor is about 8.3 relative to tested ultimate shear load capacities of assemblies with connections to wood materials. Overall, this approach resulted in a reasonably consistent basis of connection performance and durability (long term deflection control) being applied to all connection options and materials considered. Analyses of the test data with respect to these performance criteria are addressed next.

As shown in Appendix C, the 5% offset yield prediction of cladding connections to wood-based materials using the NDS Yield Theory (AFPA/NDS, 2005; AFPA/TR-12, 1999) with the gap parameter resulted in a reasonably accurate prediction of the shear load at a deflection of 0.015 inch based on the connection assembly tests. The prediction had a slight non-conservative bias of about 7% in over-predicting tested shear loads at a 0.015-inch deflection. Thus, for calculation purposes in deriving building code requirements (see Appendix D), the use of a 5% offset yield prediction was considered an adequate basis of designing for a 0.015-inch deflection limit, especially with an additional safety factor of 1.5 applied to the calculated result for purpose of controlling potential long-term creep effects.

Design Methodology for Cladding Connections to Steel Framing – As mentioned, a suitable design theory for gapped connections (i.e., with foam sheathing in between the connected parts) does not currently exist for cold-formed steel framing. Thus, the test data were evaluated to develop an empirical “gap reduction factor” approach to be applied with the screw fastener connection design approach found in AISI S100 (2007), Section E4. Evaluating the data in Appendix B for cladding connections to steel framing resulted in empirical gap reduction factor equations to be applied as a reduction factor adjustment to Equation E4.3.1-1 in AISI S100-07 (Section E4.3.1) to account for gap effects due to the presence of foam sheathing between the connected parts. This approach was at least in part modeled after a similar strength-based approach proposed for much smaller gaps (Bambach and Rasmussen, 2007). However, the approach used in this study provided gap reduction factors that controlled shear strength to a 0.015-inch deflection limit for reasons mentioned earlier. Thus, when calculating P_{ns} (nominal connection shear resistance) per AISI S100-07 Equation E4.3.1-1 (tilting failure mode) and applying the required safety factor of 3 per AISI S100-07 Section E4, the resulting factored design value provides a design resistance value approximating that for a 0.015-inch deflection (slip).

To implement the gap reduction factor procedure described above and provide a means of calculating siding connection requirements discussed in the next section, the screw fastener design method in AISI S100-07 Section E4.3.1 was modified as follows (modifications shown as underlined):

E4.3.1 Shear Strength [Resistance] Limited by Tilting and Bearing

The nominal shear strength [resistance] per screw, P_{ns} , shall be determined in accordance with this section.

For $t_2/t_1 \leq 1.0$, P_{ns} shall be taken as the smallest of

$$P_{ns} = 4.2 (t_2^3 d)^{1/2} F_{u2} \quad (\text{Eq. E4.3.1-1})$$

$$P_{ns} = 2.7 t_1 d F_{u1} \quad (\text{Eq. E4.3.1-2})$$

$$P_{ns} = 2.7 t_2 d F_{u2} \quad (\text{Eq. E4.3.1-3})$$

For $t_2/t_1 \geq 2.5$, P_{ns} shall be taken as the smallest of

$$P_{ns} = 2.7 t_1 d F_{u1} \quad (\text{Eq. E4.3.1-4})$$

$$P_{ns} = 2.7 t_2 d F_{u2} \quad (\text{Eq. E4.3.1-5})$$

For $1.0 < t_2/t_1 < 2.5$, P_{ns} shall be calculated by linear interpolation between the above two cases.

For connections with a gap between the connected steel parts filled with a material with properties at least equivalent to Type II Expanded Polystyrene Foam (ASTM C578), Eq. 4.3.1-1 shall be multiplied by one of the following gap effect reduction factors, G_r , as appropriate:

$$\underline{G_r = 0.17 - 0.0048(r)} \quad (\text{for \#10 self-drilling, tapping screw in minimum 54 mil and 50 ksi steel})$$

$$\underline{G_r = 0.19 - 0.0068(r)} \quad (\text{for \#10 screw in minimum 43 mil and 33ksi steel})$$

$$\underline{G_r = 0.16 - 0.0061(r)} \quad (\text{for \#8 or \#10 screw in minimum 33 mil and 33ksi steel})$$

where,

G_r = gap effect reduction factor for Eq. E4.3.1-1

$r = d_{sep}/d$

d_{sep} = the distance between the connected steel parts (i.e., gap)

The above G_r equations apply only to joints where r is 21 or less resulting in a minimum joint deflection after application of the required ASD safety factor of 0.015 inch at the ASD design load. The material placed against the fastener head must be minimum 33mil and 33 ksi steel or minimum 3/8-inch thick wood based or similar material with a specific gravity of not less than 0.42. For small gaps with $0 < r < 2$, the value of G_r need not be less than $(1 - r/2)$.

The G_r factor equations as applied above are shown in Figure 3.4 relative to test data for tested assemblies with 33 mil hat channel and various thicknesses of foam sheathing (range of 'r' values), steel thicknesses (33 mil and 54 mil), and screw sizes (#8 and #10). Not shown in Figure 4 are data for wood furring, although the results are very similar. Because the results were similar and a means of predicting connections of wood-to-steel parts (i.e., wood furring to steel studs) was not separately developed, it was deemed sufficient to permit substitution of a wood furring or cladding material for design value predictions based on the 33 mil hat channel.

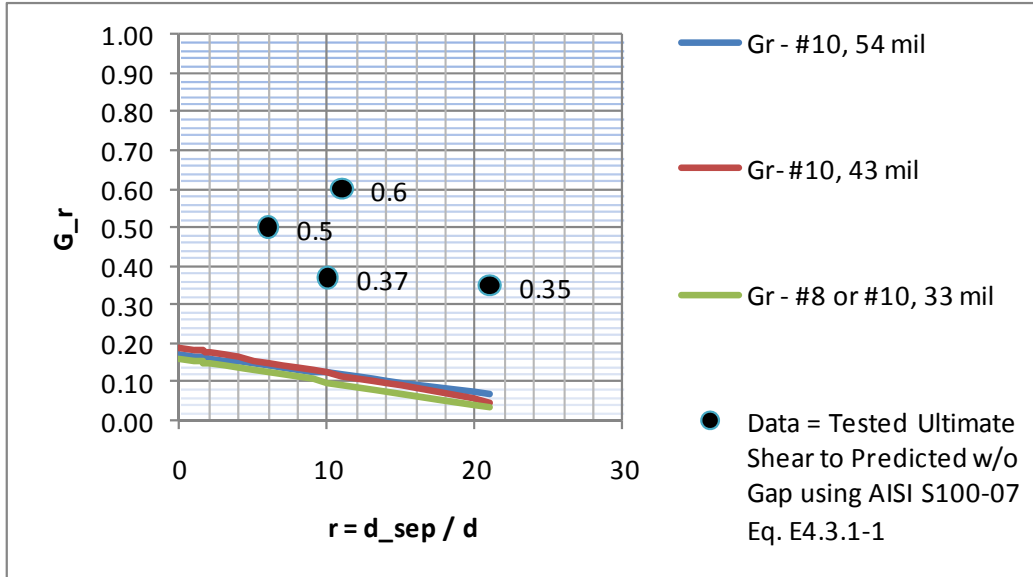

Figure 3.4. Plot of gap reduction factor equations vs. test data at failure load.

The plotted data points (●) in Figure 3.4 represent the ratio of tested ultimate capacity to the predicted nominal capacity using AISI S100-07 Eq. 4.3.1-1 for tested joints with gaps resulting in values of ‘r’ as shown on the x-axis. The G_r lines at the bottom of the plot are the linear gap effect reduction factor equations applied to AISI S100-07 Eq. 4.3.1-1 at the nominal strength level as presented above in the modified design methodology. The actual design result, after application of a safety factor of 3, would result in connection design shear values that fall below these G_r lines by a factor of 3 which correspond to a 0.015-inch deflection limit as discussed previously. Thus, Figure 3.4 illustrates the margin of safety and relationship between actual tested performance and the design method discussed above.

Prescriptive Requirements for Building Codes

Tables 3.7 and 3.8 present recommended building code requirements for siding attachments to steel framing and wood framing with an intervening layer of continuous insulation. Permissible thicknesses of continuous insulation range up to 4 inches depending on the fastener type, framing type, fastener spacing, and siding weight. These tables are extracted from a more comprehensive building code proposal included in Appendix D. The reader is cautioned that Tables 3.7 and 3.8 should be used with consideration of the additional requirements included in Appendix D.

The siding attachments to steel framing in Tables 3.7 and 3.8 were analyzed using the modified AISI S100-07 design method discussed in the previous section as derived from test data. The attachments to wood framing were derived using the AFPA/NDS (2005) and AFPA/TR-12 (1999) yield equations (5% offset yield values) with gap parameter discussed previously. In both cases, the analysis approach limited siding deflection to no more than about 0.015-inch deflection due to weight of the siding acting on the connection.

To facilitate prescribing connection requirements in Tables 3.7 and 3.8, three siding weight classes were used. The 3psf siding weight class covers products like fiber-cement siding (and also conservatively applies to light-weight siding products such as vinyl siding). The 11 psf category is meant to address medium weight siding materials such as Portland cement plaster. The 25 psf siding weight class addresses heavy weight siding materials such as adhered masonry veneers. In all cases, only standardized or code-recognized fasteners were considered to avoid problems with including proprietary (sole source) solutions in model building codes or state and local building codes. However, the design approaches discussed earlier in this report which serve as the basis of Tables 3.7 and 3.8 are potentially applicable to a variety of proprietary fasteners.

**TABLE 3.7
SIDING MINIMUM FASTENING REQUIREMENTS
FOR DIRECT SIDING ATTACHMENT OVER FOAM PLASTIC SHEATHING
TO SUPPORT SIDING DEAD LOAD¹**

Siding Fastener Through Foam Sheathing into:	Siding Fastener -Type and Minimum Size ²	Siding Fastener Vertical Spacing (inches)	Maximum Foam Sheathing Thickness (inches)					
			16"oc Fastener Horizontal Spacing			24"oc Fastener Horizontal Spacing		
			Siding Weight:			Siding Weight:		
			3 psf	11 psf	25 psf	3 psf	11 psf	25 psf
Wood Framing (minimum 1-1/4 inch penetration)	0.113" diameter nail	6	4	3	1	4	2	0.75
		8	4	2	0.75	4	1.5	DR
		12	4	1.5	DR	3	0.75	DR
	0.120" diameter nail	6	4	3	1.5	4	2	0.75
		8	4	2	1	4	1.5	0.5
		12	4	1.5	0.5	3	1	DR
	0.131" diameter nail	6	4	4	1.5	4	3	1
		8	4	3	1	4	2	0.75
		12	4	2	0.75	4	1	DR
Steel Framing (minimum penetration of steel thickness + 3 threads)	#8 screw into 33 mil steel or thicker	6	3	3	1.5	3	2	DR
		8	3	2	0.5	3	1.5	DR
		12	3	1.5	DR	3	0.75	DR
	#10 screw into 33 mil steel	6	4	3	2	4	3	0.5
		8	4	3	1	4	2	DR
		12	4	2	DR	3	1	DR
	#10 screw into 43 mil steel or thicker	6	4	4	3	4	4	2
		8	4	4	2	4	3	1.5
		12	4	3	1.5	4	3	DR

For SI: 1 inch = 25.4 mm; 1 pound per square foot (psf) = 0.0479 kPa

DR = design required

1. Tabulated requirements are based on wood framing of Spruce-Pine-Fir or any wood species with a specific gravity of 0.42 or greater in accordance with AFPA/NDS and

minimum 33 ksi steel for 33 mil and 43 mil steel and 50 ksi steel for 54 mil steel or thicker.

2. Fasteners shall comply with appropriate standards and manufacturer's installation instructions, or be otherwise approved for the intended application.
3. Refer to Appendix D for additional requirements related to use of this table.

**TABLE 3.8
FURRING MINIMUM FASTENING REQUIREMENTS
FOR APPLICATION OVER FOAM PLASTIC SHEATHING
TO SUPPORT SIDING WEIGHT^{1,2}**

Furring Material	Framing Member	Fastener Type and Minimum Size	Minimum Penetration into Wall Framing (inches)	Fastener Spacing in Furring (inches)	Maximum Thickness of Foam Sheathing (inches)						Allowable Design Wind Pressure (psf)	
					16"oc Furring ⁴			24"oc Furring ⁴				
					Siding Weight:			Siding Weight:			16"oc Furring	24"oc Furring
					3 psf	11 psf	25 psf	3 psf	11 psf	25 psf		
Minimum 1x Wood Furring ³	Minimum 2x Wood Stud	Nail (0.120" shank; 0.271" head)	1-1/4	8	4	4	1.5	4	2	1	42.6	28.4
				12	4	2	1	4	1.5	0.5	28.4	18.9
				16	4	2	0.5	4	1	DR	21.3	14.2
		Nail (0.131" shank; 0.281" head)	1-1/4	8	4	4	2	4	3	1	46.5	31.0
				12	4	3	1	4	2	0.75	31.0	20.7
				16	4	2	0.75	4	1.5	DR	23.3	15.5
	#8 wood screw ⁵	1	1-1/2	12	4	4	1.5	4	3	1	98.9	66.0
				16	4	3	1	4	2	0.5	74.2	49.5
				24	4	2	0.5	4	1	DR	35.1	23.4
		1/4" lag screw ⁵	1-1/2	12	4	4	3	4	4	1.5	140.4	93.6
				16	4	4	2	4	3	1	79.0	52.7
				24	4	3	1	4	2	0.5	35.1	23.4
Minimum 33mil Steel Hat Channel or Minimum 1x Wood Furring ³	33 mil Steel Stud	#8 screw (0.285" head)	Steel thickness +3 threads	12	3	1.5	DR	3	0.5	DR	52.9	35.3
				16	3	1	DR	2	DR	DR	39.7	26.5
				24	2	DR	DR	2	DR	DR	26.5	17.6
		#10 screw (0.333" head)	Steel thickness +3 threads	12	4	2	DR	4	1	DR	62.9	41.9
				16	4	1.5	DR	3	DR	DR	47.1	31.4
				24	3	DR	DR	2	DR	DR	31.4	21.0
	43 mil or thicker Steel Stud	#8 screw (0.285" head)	Steel thickness +3 threads	12	3	1.5	DR	3	0.5	DR	69.0	46.0
				16	3	1	DR	2	DR	DR	51.8	34.5
				24	2	DR	DR	2	DR	DR	34.5	23.0
		#10 screw (0.333" head)	Steel thickness +3 threads	12	4	3	1.5	4	3	DR	81.9	54.6
				16	4	3	0.5	4	2	DR	61.5	41.0
				24	4	2	DR	4	0.5	DR	35.1	23.4

For SI: 1" = 25.4 mm; 1 pound per square foot (psf) = 0.0479 kPa. DR = design required

1. Table values are based on: (1) minimum 3/4-inch (19.1 mm) thick wood furring and wood studs of Spruce-Pine-Fir or any softwood species with a specific gravity of 0.42 or greater per AFPA/NDS, (2) minimum 33 mil steel hat channel furring of 33 ksi steel, and (3) steel framing

of indicated nominal steel thickness and minimum 33 ksi steel for 33mil and 43 mil steel and 50 ksi steel for 54 mil steel or thicker. Steel hat channel shall have a minimum 7/8-inch (22.2 mm) depth.

2. Fasteners shall comply with appropriate standards and manufacturer's installation instructions, or be otherwise approved for the intended application.
3. Where the required siding fastener penetration into wood material exceeds $\frac{3}{4}$ inch (19.1 mm) and is not more than 1-1/2 inches (38.1 mm), a minimum 2x wood furring shall be used unless approved deformed shank siding nails or siding screws are used to provide equivalent withdrawal strength allowing connection to 1x wood furring.
4. Furring shall be spaced a maximum of 24"oc in a vertical or horizontal orientation. In a vertical orientation, furring shall be located over wall studs and attached with the required fastener spacing. In a horizontal orientation, furring strips shall be fastened at each stud intersection with a number of fasteners equivalent to the required fastener spacing. In no case shall fasteners be spaced more than 24 inches (0.6 m) apart.
5. Lag screws shall be installed with a standard cut washer. Lag screws and wood screws shall be pre-drilled in accordance with AF&PA/NDS. Approved self-drilling screws of equal or greater shear and withdrawal strength shall be permitted without pre-drilling.
6. Refer to Appendix D for additional requirements related to use of this table.

Conclusions

In general, all of the objectives of Task 3 were achieved. In particular, useful applications of the data have resulted in new means of designing cladding or similar connections to steel framing when a gap exists between the joined parts, such as required for continuous (rigid foam) insulation. Furthermore, the NDS Yield Theory for general wood connections has been verified and extended for appropriate application to cladding connections over foam sheathing. In both cases, practical solutions for continuous insulation thicknesses up to 4 inches were achieved as represented in model building code proposals included in Appendix D and the excerpted siding attachment tables included in this report (see Tables 3.7 and 3.8).

Recommendations

Additional work is recommended in the area of cladding connections to wood-based sheathing materials, such as OSB. While the research indicated feasibility, areas of concern needing further investigation include effects of limited penetration lengths of screw and nail fasteners on withdrawal capacity and effects of creep on long term cladding fastener performance in wood-based sheathing materials. In addition, research is recommended for steel framing to develop a generalized, mechanics-based connection theory similar to the NDS Yield Theory for wood connections. Such a connection design approach for cold-formed steel framing would promote a wider variety of connection solutions and innovation.

References

- AFPA/NDS (2005). National Design Specification for Wood Construction, ANSI/AF&PA NDS-2005, American Forest and Paper Association, Washington, DC.
- AFPA/TR-12 (1999). General Dowel Equations for Calculating Lateral Connection Values. Technical Report 12. American Forest and Paper Association, Washington, DC.
- AISI S100 (2007). North American Specification for the Design of Cold-Formed Steel Structural Members, AISI/COS/NASPEC 2007. American Iron and Steel Institute, Washington, DC.
- Bambach, M. R. and Rasmussen, K. J. R.(2007). Behavior of Self-Drilling Screws in Light-Gauge Steel Construction, *J. of Struct. Engr.*, 133:6 (895), American Society of Civil Engineers, Reston, VA.
- PEI (2010a). Evaluation of Siding Attachment Methods using Various Materials, Report No. 2009-1407, Progressive Engineering, Inc., Goshen, IN
- PEI (2010b). Evaluation of Siding Attachment Methods using Various Materials, Report No. 2010-128, Progressive Engineering, Inc., Goshen, IN (revised 3/9/2010)
- USDA/FPL (1986a). Lateral Load-Bearing Capacity of Nailed Joints Based on the Yield Theory (Theoretical Development). Research Paper FPL 469. U.S. Department of Agriculture, Forest Service, Forest Products Laboratory, Madison, WI.
- USDA/FPL (1986b). Lateral Load-Bearing Capacity of Nailed Joints Based on the Yield Theory (Experimental Verification). Research Paper FPL 470. U.S. Department of Agriculture, Forest Service, Forest Products Laboratory, Madison, WI.

TASK 3 APPENDICES

APPENDIX A – TEST PLAN

November 25, 2009

(revised to exchange 280 single fastener shear tests for 48 additional assembly tests, 1/10/10)

Introduction and Background Information

The purpose of this test program is to provide data to determine the shear and withdrawal performance of siding connections through thick foam sheathing (up to 4” thickness) and to confirm appropriate use or modification of existing connection design theory (i.e., AISI S100 and AF&PA-NDS) for predicting performance (strength and stiffness or joint slip).

Two methods of siding attachment are considered in this test program: (1) connection of siding or furring to a sheathing material, such as OSB, rather than directly to studs and (2) connection of siding or furring directly to wall framing (studs). These configurations are illustrated in Figure 1 (see Figure 1 in report). Screws and nails will be evaluated for this purpose. Cold-formed steel framing is the primary focus of this project, so testing of siding connections will focus on attachments to wood structural panel sheathing (i.e., OSB) and to steel studs. However, some tests of connections to wood framing are also included for benchmarking purposes.

Tests will include (1) single fastener tests with fasteners alone installed into the substrate material (i.e., OSB sheathing or steel stud) such that they act as cantilevers and (2) full mock-up assemblies so that actual assembly performance of the connection can be assessed (see assemblies in Figure 1). Testing methods and rigging shall follow accepted industry standards (i.e., ASTM D1761) for testing of connections with modifications as necessary to accommodate the special conditions of this test plan. Tests of material properties (i.e., density of wood materials, tension yield strength of steel materials, bending yield stress of fasteners, etc.), as required, shall also follow accepted industry testing methods (i.e., ASTM E8, ASTM D6395, ASTM F1575, etc.).

SCOPE OF WORK

PART 1 – Single Fastener Tests in OSB Sheathing

Figure 2 illustrates the test configuration and loading conditions intended for the fastener withdrawal and shear tests outlined separately in Tasks 1 and 2 below. In conducting the shear tests (Task 1.1), attachment of rigging to the fastener head shall allow free rotation of the fastener head and shank such that the fastener behaves as a true cantilever, fixed only at the base.

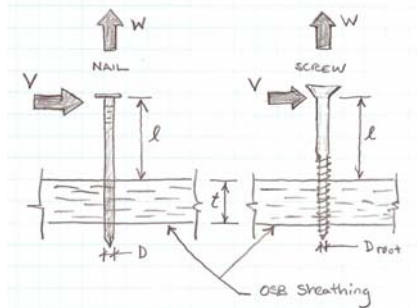

Figure 2. Test Configuration for Fasteners in Sheathing

Task 1.1: Single Fastener Shear Tests in OSB Sheathing

NOTE: Task 1.1 shear tests as shown below were not conducted because initial testing of full assemblies in Part 3 indicated greater benefit in conducting additional assembly tests in lieu of these single fastener tests. However, material property testing in accordance with this task was conducted for materials used in the other tasks.

Single Fastener Shear Tests (V)

- Screw Size/Types (3): #6 drywall/deck screw (0.099” root diam.);
#8 wood screw (0.131” root diam.);
1/4” lag screw (0.173” root diameter)
- Nail Size/Types (3): 0.099”, 0.135”
- Sheathing Thicknesses (2): 7/16”, 3/4” (OSB, G=0.5)
- Fastener Cantilever (4): 0”, 1/2”, 1”, 2”, 4”
- No. of reps: 5

A maximum total of 160 tests are planned using a combination of the above test variables as follows:

Fastener Type/Size	Cantilever Lengths	Sheathing Thicknesses	No. of Tests
#7 x 2” bugle head, coarse, exterior drywall screw (www.grabberman.com , Item # VB500RG) (*)	0”, 1/2”, 1” (3)	7/16”, 3/4” (2)	3x2x5reps = 30
#8 x 1” standard wood screw per ANSI B18.6.1 (Fastenal Catalogue)	0”		1x2x5reps = 10
#8 x 2” standard wood screw per ANSI B18.6.1 (Fastenal Catalogue)	1”		1x2x5reps = 10
#8 x 3” standard wood screw per ANSI B18.6.1 (Fastenal Catalogue) (*)	2”		1x2x5reps = 10
1/4”x1” standard lag screw per ANSI B18.2.1	0”		1x2x5reps = 10
1/4”x2” standard lag screw per ANSI B18.2.1	1”		1x2x5reps = 10
1/4”x3” standard lag screw per ANSI B18.2.1	2”		1x2x5reps = 10
1/4”x6” standard lag screw per ANSI B18.2.1 (*)	4”		1x2x5reps = 10
7d box nail (0.099”x2-1/4”) bright,smooth per ASTM F1667 (*)	0”, 1/2”, 1” (3)		3x2x5reps = 30
16d box nail (0.135”x3-1/2”) bright,smooth per ASTM F1667 (*)	0”, 1”, 2” (4)		3x2x5reps = 30

(*) fastener bending strength tests required only on these indicated fasteners/sizes for Part 1. See Parts 2 and 3 for additional fastener types/sizes requiring bending strength tests.

Load-deflection plots to peak shear capacity (or lateral deflections of not less than 3/8") shall be reported for each fastener, including a tabulation of results for average peak capacity, average deflection at peak capacity, and average capacities at deflections of 0.015", 1/8", 1/4", and 3/8". The coefficient of variation (COV) associated with each average shall also be reported. In addition, failure modes in accordance with AF&PA/NDS 2005 connection failure (yield) modes shall be reported.–The bending yield and ultimate stress by 3-point loading shall be determined for a representative sample (5 ea) of the fasteners tested, including fastener diameter to 0.001" precision. Also, the density of a representative sample (5) of the two OSB material thicknesses shall be determined and reported. Where the same materials are used in subsequent tasks, additional material property testing shall not be required.

Task 1.2: Single Fastener Withdrawal in OSB Sheathing

Fastener Withdrawal Tests (W)

Fastener Types (6): 7d box nail (0.099"x2-1/4") bright, smooth per ASTM F1667;
 16d box nail (0.135"x3-1/2") bright, smooth per ASTM F1667;
 #8 x 3" standard wood screws* per ANSI B18.6.1 (Fastenal Cat.);
 1/4"x3" standard lag screw per ANSI B18.2.1
 Sheathing Types (2): 7/16" OSB, 3/4" OSB
 No. of Reps: 6

Total No. of Tests = 4x2x6 = 48 fastener withdrawal tests

Load deflection plots for each fastener shall be reported, including a tabulation of average peak withdrawal capacity and COV. All nails shall be smooth shank and uncoated (or with coating removed).

PART 2 – Single Fastener Shear Tests in Steel Studs

NOTE: Part 2 tests as shown below were not conducted because initial testing of full assemblies in Part 3 indicated greater benefit in conducting additional assembly tests in lieu of these single fastener tests. However, material property testing in accordance with this task was conducted for materials used in the other tasks. If pursued in future research, these tests may be useful in fulfilling the report’s recommendation to develop a mechanics-based shear connection design methodology for connections to steel framing that account for joint gap effects and connection of various other materials to steel framing.

The single-fastener shear test configuration envisioned for this research is shown in Figure 3. This test configuration will be applied to the following test conditions or variables:

Single Fastener Shear Test Parameters:

Screw Cantilever (4): 0", 1/2", 1", 2", 4"
 Screw Sizes (2): #8 and #10, self-drilling/tapping screws (see table below)
 Screw Type (1): one type with a given head style (see table below)
 Stud Size (1): 1-5/8" wide flange with 1/2" lip length
 Stud Yield Stress(1): as received (33 ksi or 50 ksi)
 Stud Steel Thickness(3): 33mil, 43 mil, and 54 mil

No. of Reps: 5

Total No. of Tests = $4 \times 2 \times 3 \times 5 = 120$ single fastener shear tests

Test Plan for Part 2 (5 reps each)

Fastener	Cantilever Lengths (inches)	Stud Thicknesses	No. of Tests
#8 x 2-3/8" bugle-head, self-drilling/tapping screw (www.grabberman.com , Item 30SRG)	0", 1/2", 1", 2" (4)	33 mil (20 g) 43 mil (18 g) 54 mil (16 g) (3)	4x3x5reps = 60
#10 x 3-1/2" bugle-head, self-drilling/tapping screw (www.grabberman.com , Item B10350SDL2RG)	0", 1", 2" (3)		3x3x5reps = 45
#10 x 5" bugle-head, self-drilling/tapping screw (www.grabberman.com , Item B10500SDRG)	4"		1x3x5reps = 15

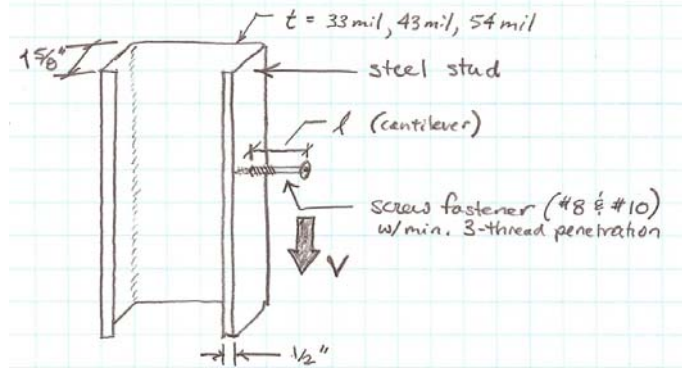

Figure 3. Test configuration for cantilevered screw fastener into the center of the flange of a steel stud.

Load-deflection plots to peak shear capacity (or lateral deflections of not less than 3/8") shall be reported for each fastener, including a tabulation of results for average peak capacity, average deflection at peak capacity, and average capacities at deflections of 0.015", 1/8", 1/4", and 3/8". The coefficient of variation (COV) associated with each average shall also be reported. In addition, failure modes shall be reported. The primary failure modes expected from the above tests include: (1) fastener bending, and (2) local rotational buckling of the stud flange element due to a point moment at the base of the fastener. The bending yield and ultimate stress of each fastener type (#8 x 2-3/8" and #10 x 5") shall be determined by three-point loading for a representative sample (5 ea.) and the fastener diameter shall also be measured to a 0.001 precision. Also, steel coupon tests for yield and ultimate stress shall be determined for a representative sample (3 ea.) of each stud thickness.

PART 3 – Connection Assembly Shear Tests

Task 3.1 – Steel Hat Channel Assembly Tests

Two assembly configurations are considered in this section – see Figure 4. The first assembly (a) involves a 33mil steel hat channel attached to sheathing and the second (b) involves 33mil hat channel attached to a steel stud, both with an intervening layer of foam sheathing. A total of four assembly specimens will be tested as described below.

Assembly (a) – Two specimen configurations for Assembly (a) are as follows (one specimen each):

- Assembly (a1) = 7/16” OSB sheathing, 1” EPS (Type II, 1.35 lbs/cuft per ASTM C578) foam, and (4) 7d box nails* (0.099”x2-1/4”) bright, smooth per ASTM F1667
- Assembly (a2) = 3/4” OSB sheathing, 4” EPS (Type II, 1.35 lbs/cuft per ASTM C578) foam, and (4) 0.135”(10g) x 6” foundry nails*, bright smooth (www.mazenails.com cat. p.29)

ADD ASSEMBLY TESTS (1/10/10):

2 more reps of Assembly (a1), total of 3 reps

2 more reps of Assembly (a2), total of 3 reps

3 reps of Assembly (a1), but with no foam sheathing

Assembly (b) – Two specimen configurations for Assembly (b) are as follows (one specimen each):

- Assembly (b1) = 33mil stud (33 or 50 ksi) with 1-5/8” flange and 1/2” lip, 1” EPS (Type II, 1.35 lbs/cuft per ASTM C578) foam, 33mil hat channel, and (2) #8 x 2-3/8” bugle-head, self-drilling/tapping screws* (www.grabberman.com, Item 30SRG)
- Assembly (b2) = 54 mil stud (33 or 50 ksi) with 1-5/8” flange and 1/2” lip, 4” EPS (Type II, 1.35 lbs/cuft per ASTM C578) foam, 33mil hat channel, and (2) #10 x 5” bugle-head, self-drilling/tapping screws* (www.grabberman.com, Item B10500SDRG)

ADD ASSEMBLY TESTS (1/10/10):

2 more reps of Assembly (b1)

3 reps of Assembly (b1), but with no foam sheathing

3 reps of Assembly (b1), but with 2” foam sheathing and use #10 x 5” screw per Assembly (b2)

2 more reps of Assembly (b2)

3 reps of Assembly (b2), but with 2” foam sheathing

() Pre-drill hat channel with bit matching outside diameter of screw or nail shank. For screws in assembly (b), also pre-drill foam to prevent threads from engaging foam. Ensure all components are “snugly” attached with no voids between layers. PLACE SMALL WASHER UNDER HEAD OF BUGLE HEAD SCREWS TO PREVENT COUNTERSINK OF SCREW HEAD INTO HAT CHANNEL TO PREVENT DEFORMATION OF HAT CHANNEL AT SCREW HEAD.*

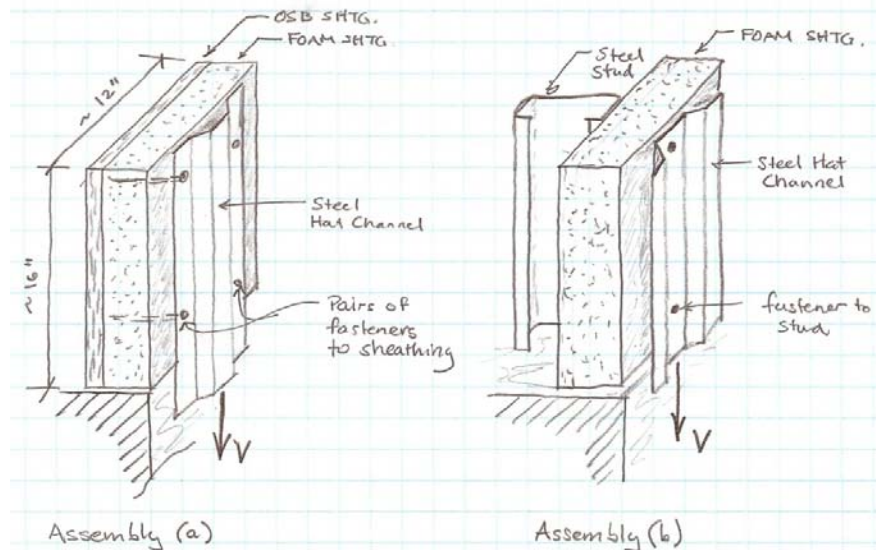

Figure 4. Steel Hat Channel Assembly Shear Test Configurations

Load-slip plots for the hat channel relative to the sheathing or stud base shall be provided for all tested assemblies with a tabulation of peak capacity, deflection at peak capacity, and force at deflections of 0.015", 1/8", 1/4", and 3/8" for each assembly. Material properties of the fasteners and sheathing shall be determined as described previously unless the same lot of materials are used. The 33mil steel hat channel is the only new material added in this task.

Task 3.2 Wood Furring Strip Assembly Tests

Two assembly configurations are considered in this section – see Figure 5. The first assembly (a) involves use of 1x wood furring attached to sheathing and the second assembly (b) involves 1x furring attached to a steel stud, both with an intervening layer of foam sheathing. A third assembly (c) (not shown in Figure 5) shall be like Assembly (b) except a wood stud shall be substituted for the steel stud. Three specimens of each assembly condition will be constructed and tested as follows:

- one for short term (e.g., <10-minute) loading to failure;
- the second for longer term loading (for a duration not to exceed 1 month with displacement readings taken at 1 day, 1 week, 2 weeks, and 4 weeks after sustained load application) at a loading representative of siding dead load (to be provided by the client) to evaluate potential creep effects; and
- the third specimen shall be tested for short term loading, but with the thickness of the furring strip at the fastener location reduced to 3/8" to emulate a minimal siding thickness.

Thus, a total of 14 assembly specimens will be constructed and tested as described below (4 – short term load tests of Assemblies (a) and (b); 4 – long-term load tests of Assemblies (a) and (b); 4 – short term loading tests with reduced furring thickness at fastener head for Assemblies (a) and (b); and, 2 – short term load tests of Assembly (c) with wood stud in lieu of steel stud):

Assembly (a) – Two configurations for Assembly (a) with three specimen conditions each are as follows:

- Assembly (a1-1) – short term loading = 7/16” OSB sheathing, 1” EPS (Type II, 1.35 lbs/cuft per ASTM C578) foam, 3/4” wood furring (G=0.42), and use (2) #8 x 3” standard wood screws* per ANSI B18.6.1 (Fastenal Cat.)
- Assembly (a1-2) – long term loading = 7/16” OSB sheathing, 1” EPS (Type II, 1.35 lbs/cuft per ASTM C578) foam, 3/4” wood furring (G=0.42), and use (2) #8 x 3” standard wood screws* per ANSI B18.6.1 (Fastenal Cat.)
- Assembly (a1-3) – short term loading with furring reduced to 3/8” (for 1-1/2” diameter at fastener location) = 7/16” OSB sheathing, 1” EPS (Type II, 1.35 lbs/cuft per ASTM C578) foam, 3/4” wood furring (G=0.42), and use (2) 7d box nails (0.099”x2-1/4”) bright, smooth per

ASTM
F1667

ADD ASSEMBLY TESTS (1/10/10):

2 more reps of Assembly (a1-1)

3 reps Assembly (a1-1), but with no foam sheathing and #8 x 1-1/2” wood screw

- Assembly (a2-1) – short term loading = 3/4” OSB sheathing, 4” EPS (Type II, 1.35 lbs/cuft per ASTM C578) foam, 3/4” wood furring (G=0.42), and use (2) 1/4”x6” lag screws* per ANSI B18.2.1 with cut washer
- Assembly (a2-2) – long term loading = 3/4” OSB sheathing, 4” EPS (Type II, 1.35 lbs/cuft per ASTM C578) foam, 3/4” wood furring (G=0.42), and use (2) 1/4”x6” lag screws* per ANSI B18.2.1 with cut washer
- Assembly (a2-3) – short term loading with furring reduced to 3/8” (for 1-1/2” diameter at fastener location) = 3/4” OSB sheathing, 4” EPS (Type II, 1.35 lbs/cuft per ASTM C578) foam, 3/4” wood furring (G=0.42), and use (2) 0.135”(10g) x 6” foundry nails*, bright smooth (www.mazenails.com cat. p.29)

ADD ASSEMBLY TESTS (1/10/10):

2 more reps Assembly (a2-1)

3 reps of Assembly (a2-1), but no foam sheathing and 1/4” x 2” lag screws

3 reps of Assembly (a2-1), but 2” foam sheathing and 1/4” x 4” lag screws

(NOTE: where different length fasteners of a given type are used in the added tests, fastener bending property tests are only required for the length of fastener used in the original test plan)

() Pre-drill wood screws and lags for threaded portion and shank separately as required for proper installation. Install nails to prevent splitting of furring strip (pre-drill only if necessary and with bit diameter 20% smaller than nail diameter). Ensure all components are “snugly” attached with no voids between layers.*

Assembly (b) – Two configurations for Assembly (b) with three specimen conditions each are as follows:

- Assembly (b1-1) – short term loading = 33 mil stud (33 or 50 ksi) with 1-5/8” flange and 1/2” lip, 1” EPS (Type II, 1.35 lbs/cuft) foam, 3/4” wood furring (G=0.42), and use (2) #8 x 2-3/8” bugle-head, self-drilling/tapping screws* (www.grabberman.com, Item 30SRG)
- Assembly (b1-2) – long term loading = 33 mil stud (33 or 50 ksi) with 1-5/8” flange and 1/2” lip, 1” EPS (Type II, 1.35 lbs/cuft) foam, 3/4” wood furring (G=0.42), and use (2) #8 x 2-3/8” bugle-head, self-drilling/tapping screws* (www.grabberman.com, Item 30SRG)
- Assembly (b1-3) – short term loading with furring reduced to 3/8” (for 1-1/2” diameter at fastener location) = 33 mil stud (33 or 50 ksi) with 1-5/8” flange and 1/2” lip, 1” EPS (Type II, 1.35 lbs/cuft) foam, 3/4” wood furring (G=0.42), and use (2) #8 x 2-3/8” bugle-head, self-drilling/tapping screws* (www.grabberman.com, Item 30SRG)

ADD ASSEMBLY TESTS (1/10/10):

2 more reps of Assembly (b1-1)

2 more reps of Assembly (b1-3)

3 reps of Assembly (b1-1), but no foam sheathing

3 reps of Assembly (b1-1), except 2” foam sheathing and (2) #10 x 5” screws per Assembly (b2-1)

- Assembly (b2-1) – short term loading = 54 mil stud (33 or 50 ksi) with 1-5/8” flange and 1/2” lip, 4” EPS (Type II, 1.35 lbs/cuft) foam, 3/4” wood furring (G=0.42), and (2) #10 x 5” bugle-head, self-drilling/tapping screws* (www.grabberman.com, Item B10500SDRG)
- Assembly (b2-2) – long term loading = 54 mil stud (33 or 50 ksi) with 1-5/8” flange and 1/2” lip, 4” EPS (Type II, 1.35 lbs/cuft) foam, 3/4” wood furring (G=0.42), and (2) #10 x 5” bugle-head, self-drilling/tapping screws* (www.grabberman.com, Item B10500SDRG)
- Assembly (b2-3) – short term loading with furring reduced to 3/8” (for 1-1/2” diameter at fastener location) = 54 mil stud (33 or 50 ksi) with 1-5/8” flange and 1/2” lip, 4” EPS (Type II, 1.35 lbs/cuft) foam, 3/4” wood furring (G=0.42), and (2) #10 x 5” bugle-head, self-drilling/tapping screws* (www.grabberman.com, Item B10500SDRG)

ADD ASSEMBLY TESTS (1/10/10):

2 more reps of Assembly (b2-1)

3 reps of Assembly (b2-1), but 2” thick foam sheathing

() Pre-drill furring and foam using bit sized to match screw outside diameter to prevent screw threads from engaging in foam and wood furring. Use screw to drill and tap metal stud. Ensure all components are “snugly” attached with no voids between layers.*

Assembly (c) – Two specimen configurations for Assembly (c) are as follows (one specimen each)

- Assembly (c1) = 2x4 stud (SPF, G=0.42), 1” EPS (Type II) foam, 3/4” wood furring (G=0.42), and (2) 0.135” x 3-1/2” 16d sinker nails*, bright smooth per ASTM F1667.
- Assembly (c2) = 2x4 stud (SPF, G=0.42), 4” EPS (Type II) foam, 3/4” wood furring (G=0.42), and (2) 1/4”x7” lag screws* per ANSI B18.2.1 with cut washer.

(*) Pre-drill lag screws for threaded portion and shank separately as required for proper installation. Install nails to prevent splitting of furring strip (pre-drill only if necessary and with bit diameter 20% smaller than nail diameter). Ensure all components are “snugly” attached with no voids between layers.

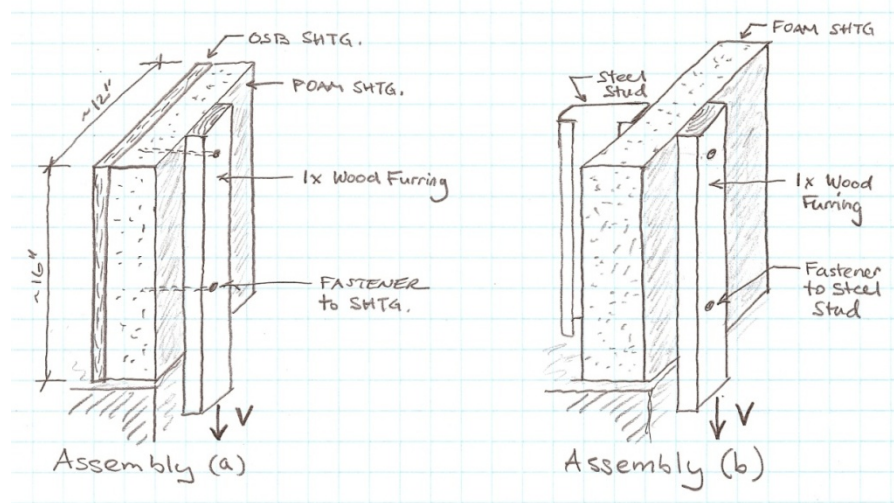

Figure 5. Wood Furring Assembly Shear Test Configurations

Load-slip plots for the hat channel relative to the sheathing or stud base shall be provided for all tested assemblies with a tabulation of peak capacity, deflection at peak capacity, and force at deflections of 0.015”, 1/8”, 1/4”, and 3/8” for each assembly. Material properties of the fasteners and sheathing shall be determined as described previously unless the same lot of materials is used for this task. The 1x wood furring strips and 2x4 wood studs are the only new materials added in this task.

APPENDIX B
TEST LAB REPORT (PEI,2010a)

APPENDIX C TO SECTION 4 - TEST LAB REPORT (PEI, 2010A)



Progressive Engineering Inc.

NEWPORT VENTURES, INC.

Evaluation of Siding Attachment Methods
using Various Materials

1/28/2010



This test report contains eighty-six (86) pages, including the cover sheet. Any additions to, alterations of, or unauthorized use of excerpts from this report are expressly forbidden.

2009-1407

58640 State Road 15 - Goshen, IN 46528
Phone: 574-533-0337 - Fax: 574-533-9736
www.p-e-i.com

1. TITLE

Evaluation of Siding Attachment Methods using Various Materials

2. OBJECTIVE

- 1) To determine the withdrawal capacity of various fasteners in 7/16" and 3/4" OSB.
- 2) To determine the shear capacity of various assemblies simulating siding or furring strips attached directly to framing (steel or wood), to OSB sheathing, or varying thicknesses of EPS foam board.
- 3) To determine the long-term creep characteristics of shear assemblies tested in Objective 2.

The above objectives were based on the Newport Ventures test plan.

This test report pertains only to the specimens tested. It remains the sole responsibility of the manufacturer to provide a product consistent to that which was tested.

3. TESTED FOR

Newport Ventures, Inc.
3760 Tanglewood Lane
Davidsonville, MD 21035

4. TESTING ORGANIZATION

Progressive Engineering Inc.
58640 State Road 15
Goshen, IN 46528
www.p-e-i.com

See IAS Evaluation Report No. TL-178 for ISO 17025 Accreditation.

5. TESTING PERSONNEL

Laboratory Manager - Jason R. Holdeman
Technician - Jacob Bontrager
Technician - Chris Stutzman



6. REFERENCE STANDARDS

ASTM D1761-06 - Standard Test Methods for Mechanical Fasteners in Wood

7. TESTING EQUIPMENT

- PEI Data Acquisition System (*PEI* #566)
- Dial Indicators (*PEI* #574 and *PEI* #676)
- Linear Transducer (*PEI* # 653)
- Load Cell (*PEI* # 122)

8. TEST SPECIMEN

A. Siding / Furring Strip

- Steel Hat Channel - Part No. DWC-7/8 20, manufactured by Dietrich Industries.
- Wood Siding / Furring Strip - 1x4 Spruce-Pine-Fir lumber, ungraded. 3/8" siding simulated by reducing the 1x4 thickness to 3/8" at the fastener locations using a 2" diameter boring drill.

B. Framing

- Wood - 2x4 Spruce-Pine-Fir, Stud Grade lumber
- Steel - 3.5" deep x 1-5/8" flange with 1/2" return leg, 33 mil or 54 mil thickness. Part No. CSJ20 and CSJ16 manufactured by Dietrich Industries.

C. Foam Board

- Expanded Polystyrene (EPS) boards 48" x 96" with thicknesses of 1", 2", and 4". (Type II, 1.35 pcf) Material purchased at Keypac Industries.

D. Sheathing

- 7/16" OSB Rated Sheathing, 24/16, DEC 09 mfd. by LP.
- 23/32" OSB Rated STURD-I-FLOOR, 24 oc, OCT-09 mfd. by GP.

8. TEST SPECIMEN (con't)

E. Fasteners

1. Nails

- 7d x 2-1/4" long Box Nails, Bright, Smooth. Manufacturer unknown.
- 16d x 3-1/2" long Common Nails, Bright, Smooth. Manufactured by X-Cell Fasteners.
- 16d x 3-1/2" long Box Nails, Hot Dipped Gavanized. Manufactured by Grip Rite, Part No. 16HGBX1. Galvanized Layer removed for testing.
- 10 Ga. x 6" long Foundry Nails, Bright, Smooth. Manufactured by Maze Nails, Part No. XFN600135.

2. Screws

- #8 x 3" long standard wood screw. Manufactured by Fastenal, Part No. 30144.
- #8 x 2" long standard wood screw. Manufactured by Fastenal, Part No. 1129733.
- 1/4" x 2" long standard lag screw. Manufactured by Fastenal, Part No. 1122061.
- 1/4" x 3" long standard lag screw. Manufactured by Fastenal, Part No. 1122065.
- 1/4" x 4" long standard lag screw. Manufactured by Hillman, Part No. HS14ZP4.
- 1/4" x 6" long standard lag screw. Manufactured by Fastenal, Part No. 1122075.
- 1/4" x 7" long standard lag screw. Manufactured by Fastenal, Part No. 22077.
- #8 x 2-3/8" bugle-head, self-drilling/tapping screws. Manufactured by Grabber, Part No. 30SRG.
- #10 x 3-1/2" bugle-head, self-drilling/tapping screws. Manufactured by Grabber, Part No. B10350SDL2RG.
- #10 x 5" bugle-head, self-drilling/tapping screws. Manufactured by Grabber, Part No. B10500SDRG.
- 1/4" Flat Washers. Manufactured by Hillman, Part No. 490687. The average measured inner diameter was .285". The average measured outer diameter was .623". The average measured thickness was .053".

A sufficient quantity of each of the materials listed were purchased to perform all of the tests. Samples were taken for each material to verify critical properties (as defined in the Newport Ventures Test Plan dated 1/10/10) and this information can be found in the Appendix section of this report.

9. TEST SPECIMEN CONSTRUCTION

A. Fastener Withdrawal Test

The sheathing was cut into 3" x 6" pieces. A hole was predrilled thru the center of the 3" x 6" area for ALL of the SCREW Withdrawal samples tested. The hole was 50% of the root diameter. A portion of the NAIL Withdrawal samples were not predrilled, as requested by the client. The NAIL Withdrawal samples labeled "Predrilled" had a hole 60% of the shank diameter predrilled thru the center of the 3" x 6" area. ALL of the fasteners were inserted into the OSB with a minimum distance of .5" from the underside of the fastener head to the sheathing surface. Care was taken to ensure that the long-axis of the fastener was perpendicular to the sheathing surface and minimal damage occurred to the sheathing during the insertion of the fastener. (Nails did cause breakout on the backside.)

B. Assembly Shear Tests

Each of the assemblies were constructed using the prescriptive method provided in Newport Ventures Test Plan dated 1/10/10. An assembly consisted of a 12" x 16" piece of foam and/or OSB, in some cases a 16" long piece of framing material, and a 20" long siding/furring strip. The siding/furring strip was oriented parallel with the 16" dimension of the backing material and flush on one end. Fasteners were inset 4" from each end of the 16" dimension, resulting in a 8" separation. The assembly construction is outlined on each data page. All nails were hand-driven, by a PEI technician, such that the head of the fastener was tight to the siding/furring strip. In the case of screws or lags, they were driven using pneumatic or electric tools until the head was tight to the siding/furring strip or flush with the siding/furring strip for buglehead or wood screws. The fasteners were tightened or hammered such that the siding/furring strip caused minimal indentation to the foam, with no voids between layers.

C. Long-Term Creep Tests

Each of the assemblies were constructed using the prescriptive method provided in Newport Ventures Test Plan dated 1/10/10. The assembly construction is outlined on each data page and utilized the same guidelines stated in Section 9B of this report.

10. TEST SET-UP

A. Fastener Withdrawal Test

The sample was positioned in a test fixture as shown in Figure 1 of ASTM D1761 . A loading fixture was slid under the fastener head.

B. Assembly Shear Tests

The sample was positioned vertically on a rigid test platform such that the siding/furring strip was not over the support and the non-flush end was at the top. (The support platform was adjusted to accommodate the various assembly depths.) The 12" x 16" backing material portion of the test sample was clamped to a rigid member located opposite the siding/furring strip. A linear transducer was connected to the siding furring strip at one end and to a formed steel plate that was clamped or fastened to the supporting member (i.e. frame, sheathing). The linear transducer was oriented parallel with the long-axis of the siding/furring strip. The top of the siding/furring strip was reinforced with a steel plate or angle to prevent splitting or crushing at the load point. A load cell was positioned over the top of the siding/furring strip and was attached to a fixed crosshead in the test machine.

C. Long-Term Creep Tests

The sample was positioned vertically on a rigid test platform such that the siding/furring strip was not over the support and the non-flush end was at the top. (The support platform was adjusted to accommodate the various assembly depths.) The 12" x 16" backing material portion of the test sample was clamped to a rigid member located opposite the siding/furring strip. A dial indicator was positioned over the top of the siding/furring strip with its base connected to the backing material. The dial indicator was oriented parallel with the long-axis of the siding/furring strip. A hole was drilled thru the siding/furring strip 2" from the bottom end. A threaded rod was set thru the hole.

The siding/furring strip was restrained from out-of-plane movement by the fasteners into the backing material. No additional restraints were provided.

11. TEST PROCEDURE

A. Fastener Withdrawal Test

The test machine was set to a load rate of .100" inches per minute. The data acquisition system recorded the load and displacement throughout the test. The test was stopped when the load was no longer increasing due to the fastener slipping. The maximum load and observations were recorded.

B. Assembly Shear Test

The test machine was set to a load rate of .200" inches per minute. This load rate was selected due to the excessive deflection before failure. The data acquisition system recorded the load and displacement throughout the test. The test was stopped when the load was no longer increasing due to the fastener withdrawal or the fasteners broke. The maximum load and failure mode(s) were recorded by the technician.

C. Long-Term Creep Test

An initial dial indicator reading was recorded. Weights were added to the threaded rod equivalent to 66% of the average load at .015" deflection when the identical assembly was tested in accordance with Section 11B of this report. Immediately after application of the weights another dial indicator reading was recorded. The dial indicator was read and recorded at a minimum of 1 day, 1 week, 2 weeks, and 4 weeks.

12. TEST RESULTS

See attached data pages and charts for details.

Progressive Engineering Inc.

ASTM D1761 Shear Testing

Date: 1/13/2010
Client: Newport Ventures, Inc.
Test: ASTM D1761 Shear Testing
Specimen Assembly No.: 3.1-(a1)

Project No.: 2009-1407
Temp.: 70.0 °F
Humidity: 21% R.H.
Load Rate: .2" per minute

Specimen Construction

Furring: Steel Hat Channel (33 mil)	Fastener: (4) 7d box nails (.099" x 2-1/4") bright, smooth
Foam: 1" EPS	Furring Pre-drill: 1/8" dia.
Sheathing: 7/16" OSB	Remaining Material Pre-drill: N/A
Stud: N/A	

Test Results

Sample	Maximum Load (lbf)	Deflection at Max. Load	Load (lbf) at:				*Connection Yield Mode
			.015" Defl.	.125" Defl.	.250" Defl.	.375" Defl.	
1	345	1.356"	78	186	243	283	IV
2	324	1.258"	64	136	182	215	IV
3	328	1.272"	44	132	177	208	IV
Average	332	1.295"	62	151	201	235	
COV	3%	4%	28%	20%	18%	18%	

*Based on Single Shear Connection in Figure 1 of the AF&PA, NDS, Technical Report 12.

8 of 86

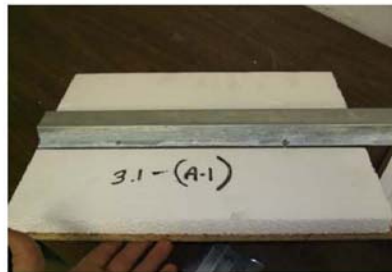

Specimen Construction



Typical Test Set-up



Typical Failure

Newport Ventures, Inc.
Shear Test on Assembly 3.1-(a1) (1" Foam)
Load vs Deflection

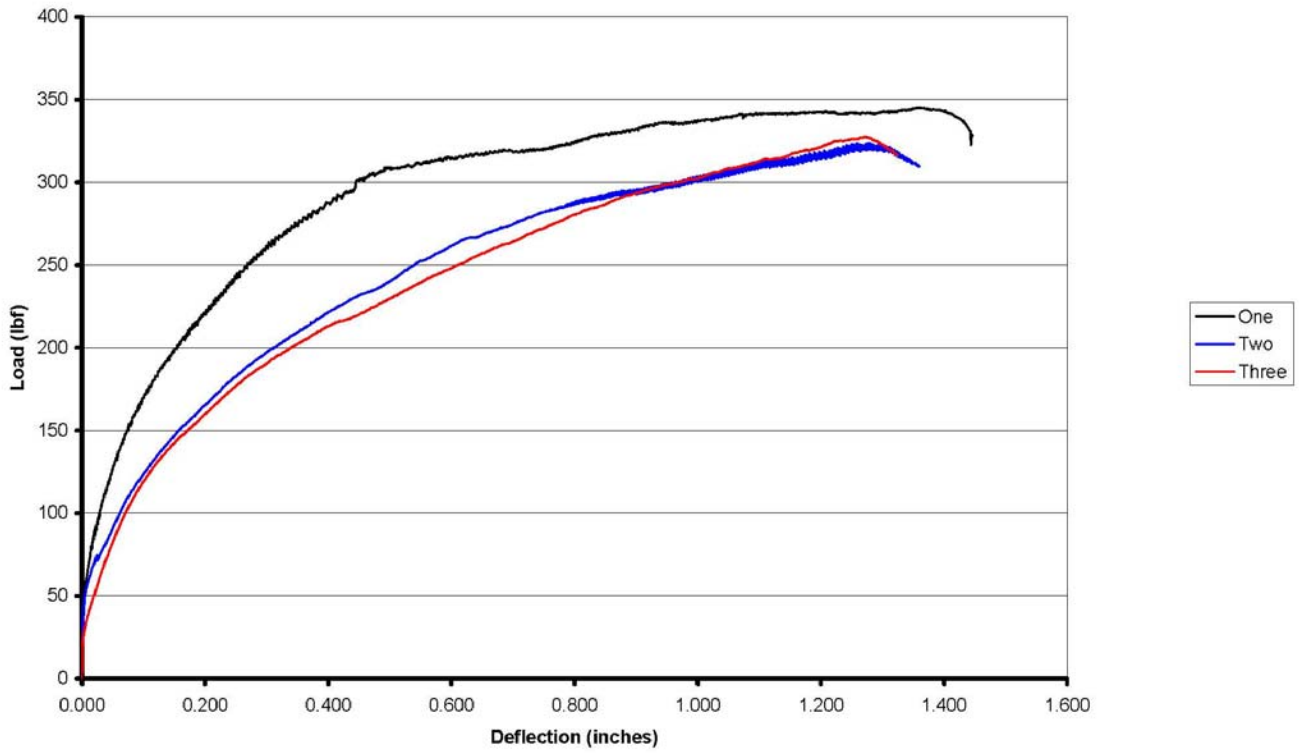

9 of 86

Progressive Engineering Inc.

ASTM D1761 Shear Testing

Date: 1/13/2010
Client: Newport Ventures, Inc.
Test: ASTM D1761 Shear Testing
Specimen Assembly No.: 3.1-(a2)

Project No.: 2009-1407
Temp.: 70.0 °F
Humidity: 21% R.H.
Load Rate: .2" per minute

Specimen Construction

Furring: Steel Hat Channel (33 mil)	Fastener: (4) .135" (10g) x 6" Foundry nails, bright, smooth
Foam: 4" EPS	Furring Pre-drill: 3/16" dia.
Sheathing: 3/4" OSB	Remaining Material Pre-drill: N/A
Stud: N/A	

Test Results

Sample	Maximum Load (lbf)	Deflection at Max. Load	Load (lbf) at:				*Connection Yield Mode
			.015" Defl.	.125" Defl.	.250" Defl.	.375" Defl.	
1	811	3.545"	58	135	220	281	III _s
2	714	3.203"	70	135	201	249	III _s
3	788	3.369"	108	179	220	273	III _s
Average	771	3.372"	79	150	214	268	
COV	7%	5%	33%	17%	5%	6%	

*Based on Single Shear Connection in Figure 1 of the AF&PA, NDS, Technical Report 12.

10 of 86



Specimen Construction



Typical Test Set-up



Typical Failure

Newport Ventures, Inc.
Shear Test on Assembly 3.1-(a2) (4" Foam)
Load vs Deflection

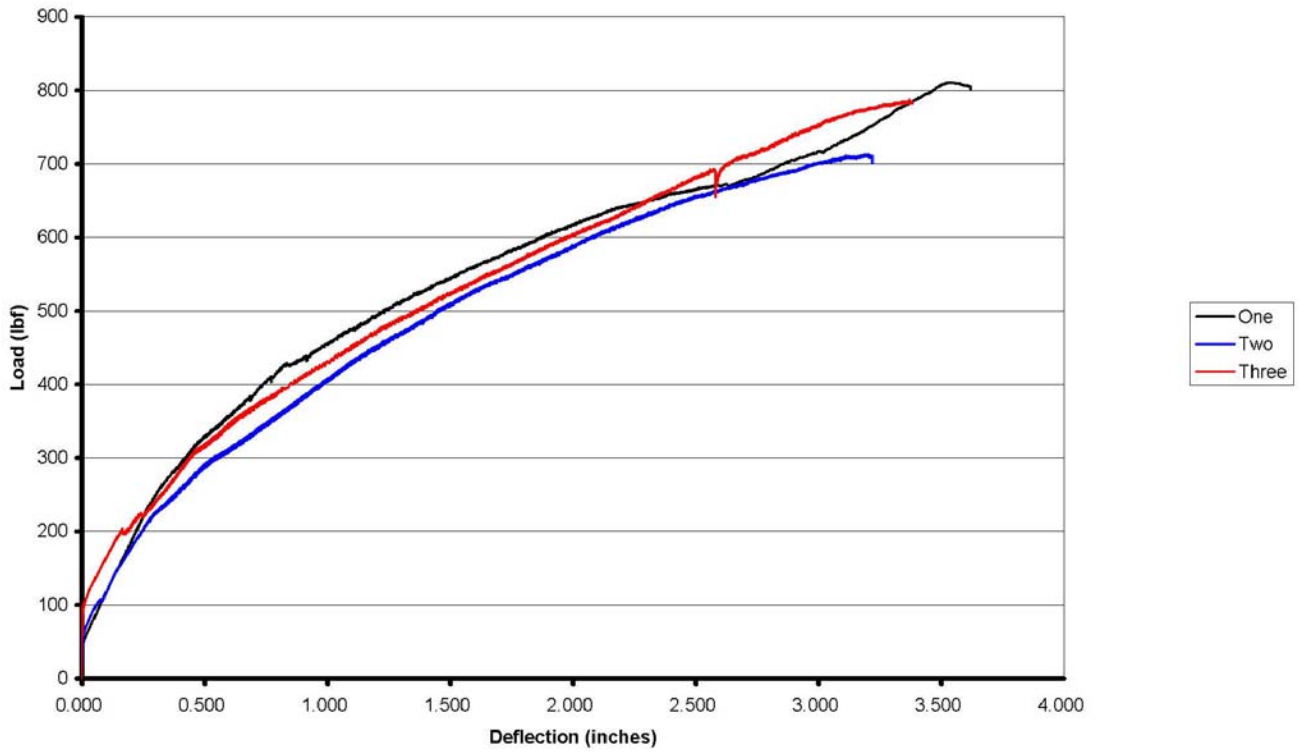

11 of 86

Progressive Engineering Inc.

ASTM D1761 Shear Testing

Date: 1/13/2010
Client: Newport Ventures, Inc.
Test: ASTM D1761 Shear Testing
Specimen Assembly No.: 3.1-(a3)

Project No.: 2009-1407
Temp.: 70.0 °F
Humidity: 21% R.H.
Load Rate: .2" per minute

Specimen Construction

Furring: Steel Hat Channel (33 mil)	Fastener: (4) 7d box nails (.099" x 2-1/4") bright, smooth
Foam: N/A	Furring Pre-drill: 1/8" dia.
Sheathing: 7/16" OSB	Remaining Material Pre-drill: N/A
Stud: N/A	

Test Results

Sample	Maximum Load (lbf)	Deflection at Max. Load	Load (lbf) at:				*Connection Yield Mode
			.015" Defl.	.125" Defl.	.250" Defl.	.375" Defl.	
1	722	.094"	360	722	722	722	III _s
2	749	.080"	350	749	749	749	III _s
3	934	.129"	241	932	934	934	III _s
Average	802	.101"	324	801	802	802	
COV	14%	25%	23%	14%	14%	14%	

*Based on Single Shear Connection in Figure 1 of the AF&PA, NDS, Technical Report 12.

12 of 86



Specimen Construction



Typical Test Set-up



Typical Failure

Progressive Engineering Inc.

Newport Ventures, Inc.
Shear Test on Assembly 3.1-(a3) (No Foam)
Load vs Deflection

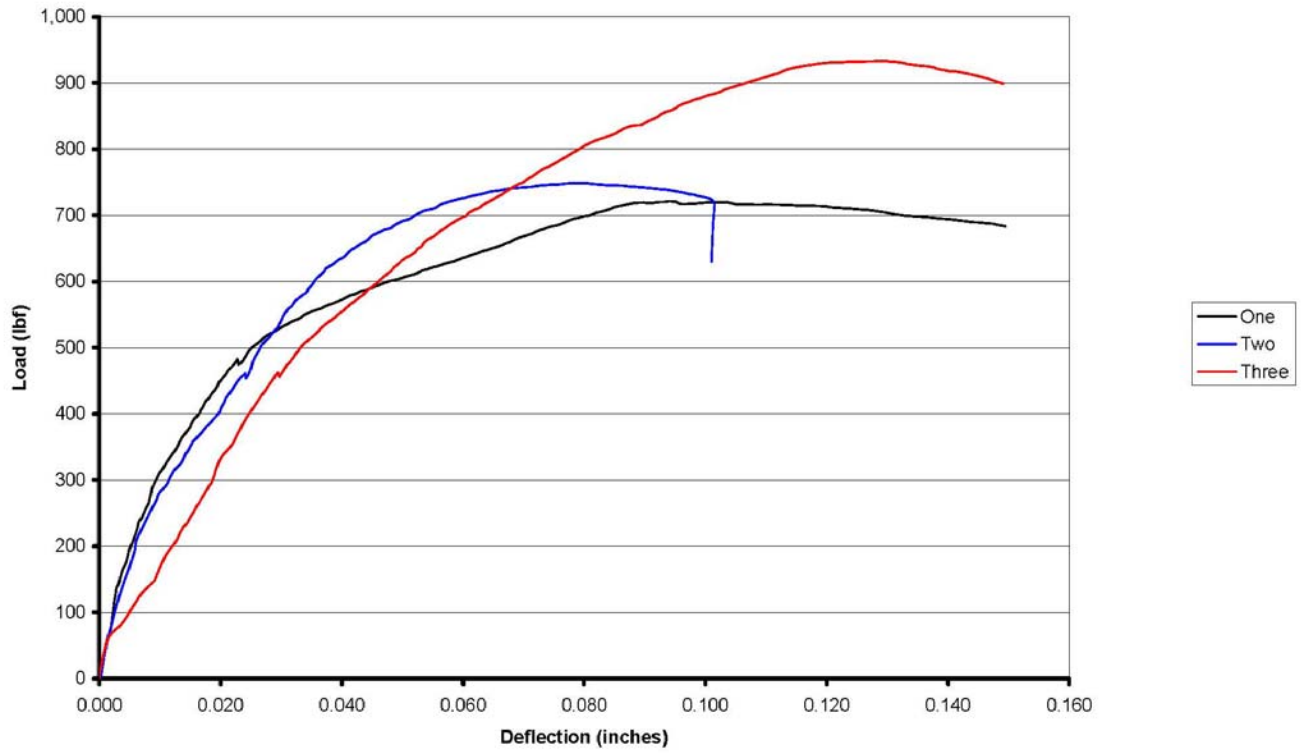

13 of 86

Progressive Engineering Inc.

ASTM D1761 Shear Testing

Date: 1/26/2010
Client: Newport Ventures, Inc.
Test: ASTM D1761 Shear Testing
Specimen Assembly No.: 3.1-(b1)

Project No.: 2009-1407
Temp.: 66.0 °F
Humidity: 24% R.H.
Load Rate: .2" per minute

Specimen Construction

Furring: Steel Hat Channel (33 mil)	Fastener: (2) #8 x 2-3/8" bugle-head screws, Item 30SRG
Foam: 1" EPS	Furring Predrill: 3/16" dia.
Sheathing: N/A	Remaining Material Predrill: 1/16" dia.
Stud: Steel (33 mil)	

Test Results

Sample	Maximum Load (lbf)	Deflection at Max. Load	Load (lbf) at:				*Connection Yield Mode
			.015" Defl.	.125" Defl.	.250" Defl.	.375" Defl.	
1	494	.801"	35	57	100	185	II
2	536	.558"	40	105	204	329	II
3	426	.600"	50	80	137	238	II
Average	485	.653"	42	81	147	251	
COV	11%	20%	18%	30%	36%	29%	

*Based on Single Shear Connection in Figure 1 of the AF&PA, NDS, Technical Report 12.

14 of 86



Specimen Construction



Typical Test Set-up



Typical Failure

Newport Ventures, Inc.
Shear Test on Assembly 3.1-(b1) (1" Foam)
Load vs Deflection

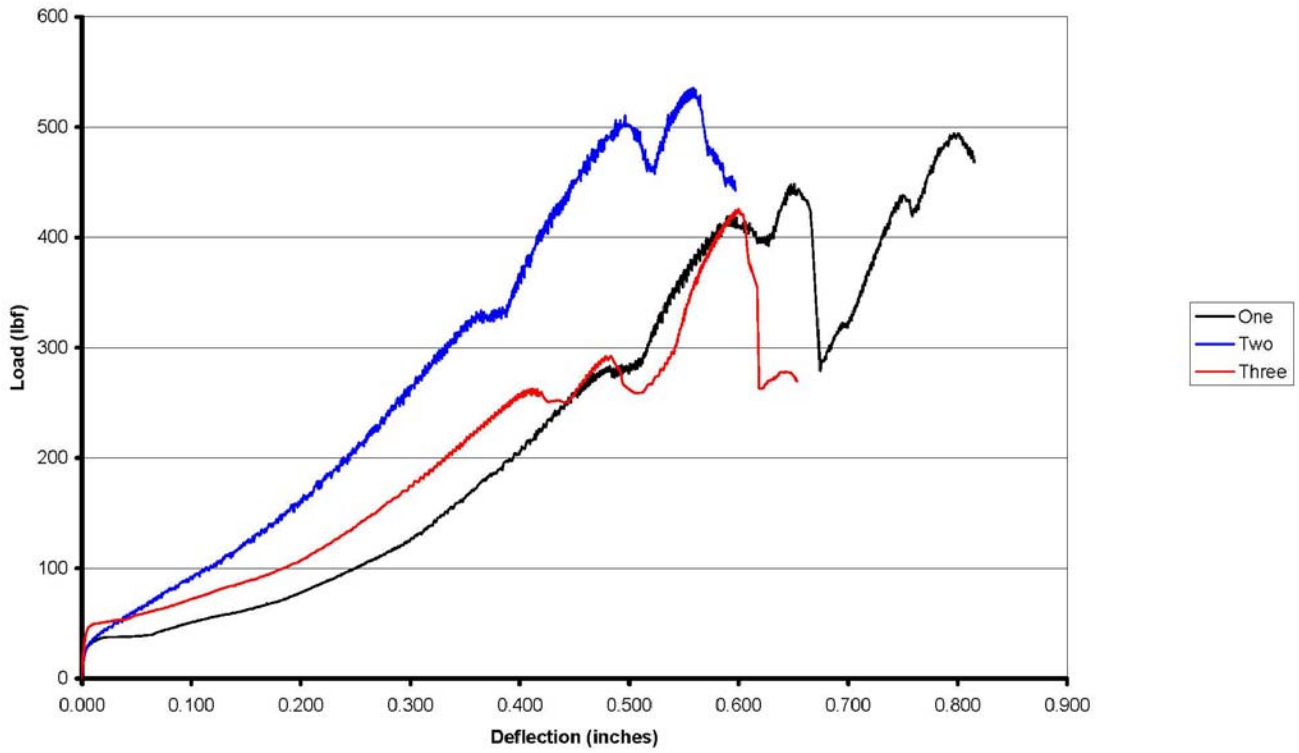

15 of 86

Progressive Engineering Inc.

ASTM D1761 Shear Testing

Date: 1/25/2010
Client: Newport Ventures, Inc.
Test: ASTM D1761 Shear Testing
Specimen Assembly No.: 3.1-(b2)

Project No.: 2009-1407
Temp.: 70.0 °F
Humidity: 23% R.H.
Load Rate: .2" per minute

Specimen Construction

Furring: Steel Hat Channel (33 mil)	Fastener: (2) #10 x 5" bugle-head screws, Item B10500SDRG
Foam: 4" EPS	Furring Predrill: 3/16" dia.
Sheathing: N/A	Remaining Material Predrill: 3/32" dia.
Stud: Steel (54 mil)	

Test Results

Sample	Maximum Load (lbf)	Deflection at Max. Load	Load (lbf) at:				*Connection Yield Mode
			.015" Defl.	.125" Defl.	.250" Defl.	.375" Defl.	
1	1092	2.175"	123	158	201	245	II
2	1136	2.333"	84	109	133	161	II
3	1116	1.730"	201	240	278	316	II
Average	1115	2.079"	136	169	204	241	
COV	2%	15%	44%	39%	36%	32%	

*Based on Single Shear Connection in Figure 1 of the AF&PA, NDS, Technical Report 12.

16 of 86



Specimen Construction



Typical Test Set-up



Typical Failure

Newport Ventures, Inc.
Shear Test on Assembly 3.1-(b2) (4" Foam)
Load vs Deflection

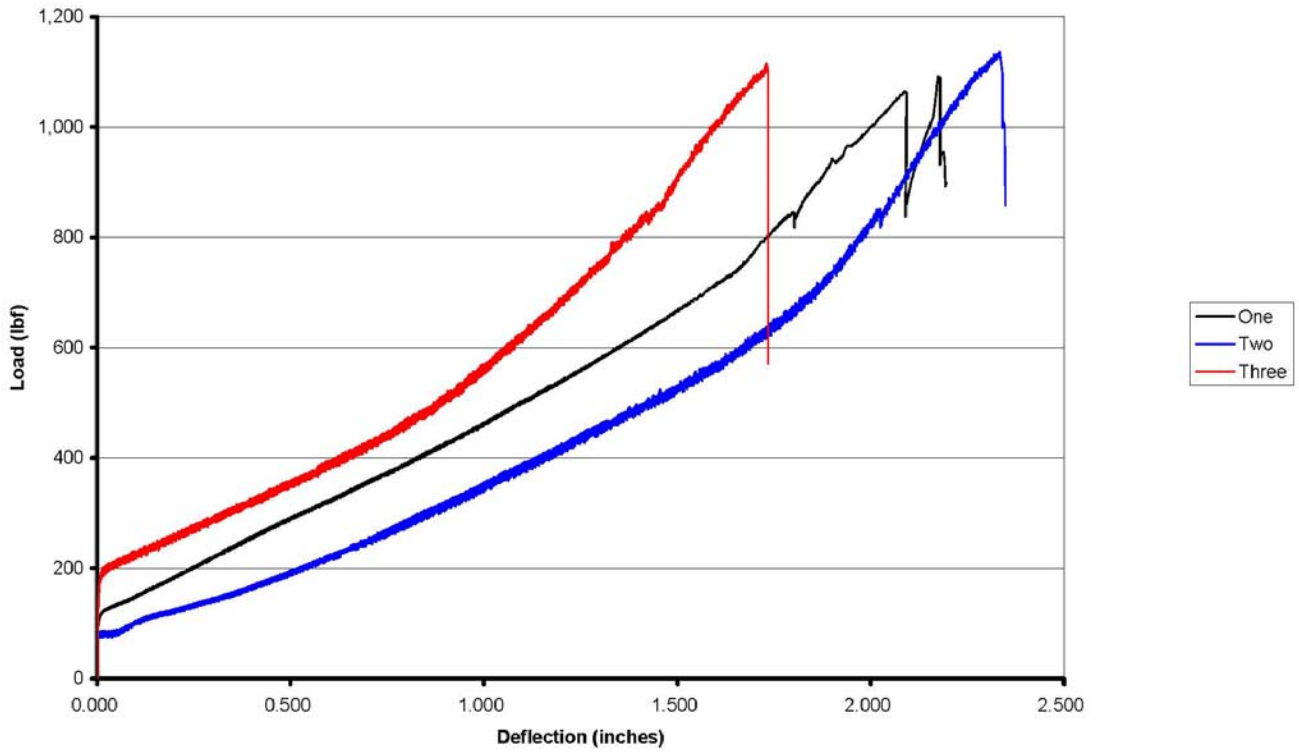

17 of 86

Progressive Engineering Inc.

ASTM D1761 Shear Testing

Date: 1/26/2010
Client: Newport Ventures, Inc.
Test: ASTM D1761 Shear Testing
Specimen Assembly No.: 3.1-(b3)

Project No.: 2009-1407
Temp.: 66.0 °F
Humidity: 24% R.H.
Load Rate: .2" per minute

Specimen Construction

Furring: Steel Hat Channel (33 mil)	Fastener: (2) #8 x 2-3/8" bugle-head screws, Item 30SRG
Foam: N/A	Furring Predrill: 1/16" dia.
Sheathing: N/A	Remaining Material Predrill: 1/16" dia.
Stud: Steel (33 mil)	

Test Results

Sample	Maximum Load (lbf)	Deflection at Max. Load	Load (lbf) at:				*Connection Yield Mode
			.015" Defl.	.125" Defl.	.250" Defl.	.375" Defl.	
1	1344	.163"	483	1239	1344	1344	I _M
2	1186	.126"	502	1186	1186	1186	I _M
3	1214	.148"	575	1142	1214	1214	I _M
Average	1248	.146"	520	1189	1248	1248	
COV	7%	13%	9%	4%	7%	7%	

*Based on Single Shear Connection in Figure 1 of the AF&PA, NDS, Technical Report 12.

18 of 86



Specimen Construction



Typical Test Set-up



Typical Failure

Progressive Engineering Inc.

Newport Ventures, Inc.
Shear Test on Assembly 3.1-(b3) (No Foam)
Load vs Deflection

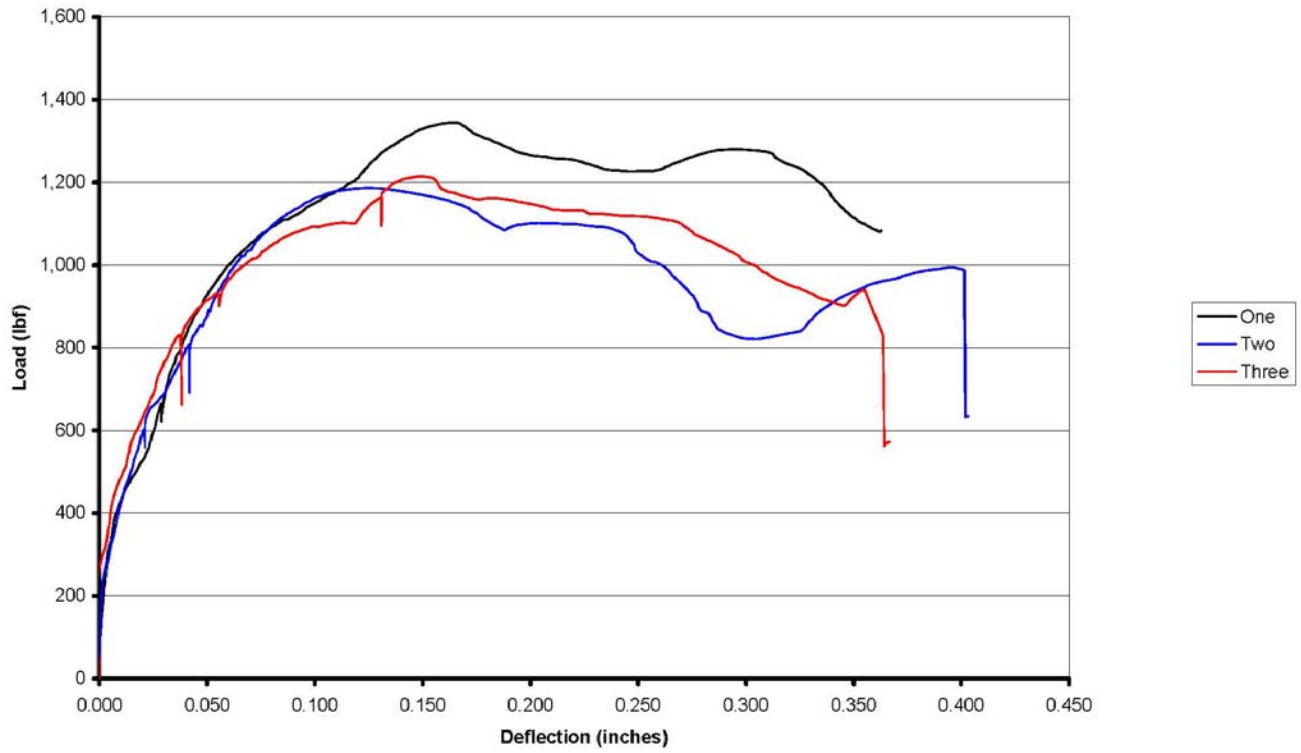

19 of 86

Progressive Engineering Inc.

ASTM D1761 Shear Testing

Date: 1/22/2010
Client: Newport Ventures, Inc.
Test: ASTM D1761 Shear Testing
Specimen Assembly No.: 3.1-(b4)

Project No.: 2009-1407
Temp.: 66.0 °F
Humidity: 24% R.H.
Load Rate: .2" per minute

Specimen Construction

Furring: Steel Hat Channel (33 mil)	Fastener: (2) #10 x 5" bugle-head screws, Item B10500SDRG
Foam: 2" EPS	Furring Predrill: 3/16" dia.
Sheathing: N/A	Remaining Material Predrill: 3/32" dia.
Stud: Steel (33 mil)	

Test Results

Sample	Maximum Load (lbf)	Deflection at Max. Load	Load (lbf) at:				*Connection Yield Mode
			.015" Defl.	.125" Defl.	.250" Defl.	.375" Defl.	
1	414	.964"	60	86	115	156	II
2	357	.780"	46	73	107	157	II
3	396	.881"	76	102	142	187	II
Average	389	.875"	61	87	121	167	
COV	7%	11%	25%	17%	15%	11%	

*Based on Single Shear Connection in Figure 1 of the AF&PA, NDS, Technical Report 12.

20 of 86



Specimen Construction

Similar to other set-ups. No picture available.

Typical Test Set-up



Typical Failure

Progressive Engineering Inc.

Newport Ventures, Inc.
Shear Test on Assembly 3.1-(b4) (2" Foam)
Load vs Deflection

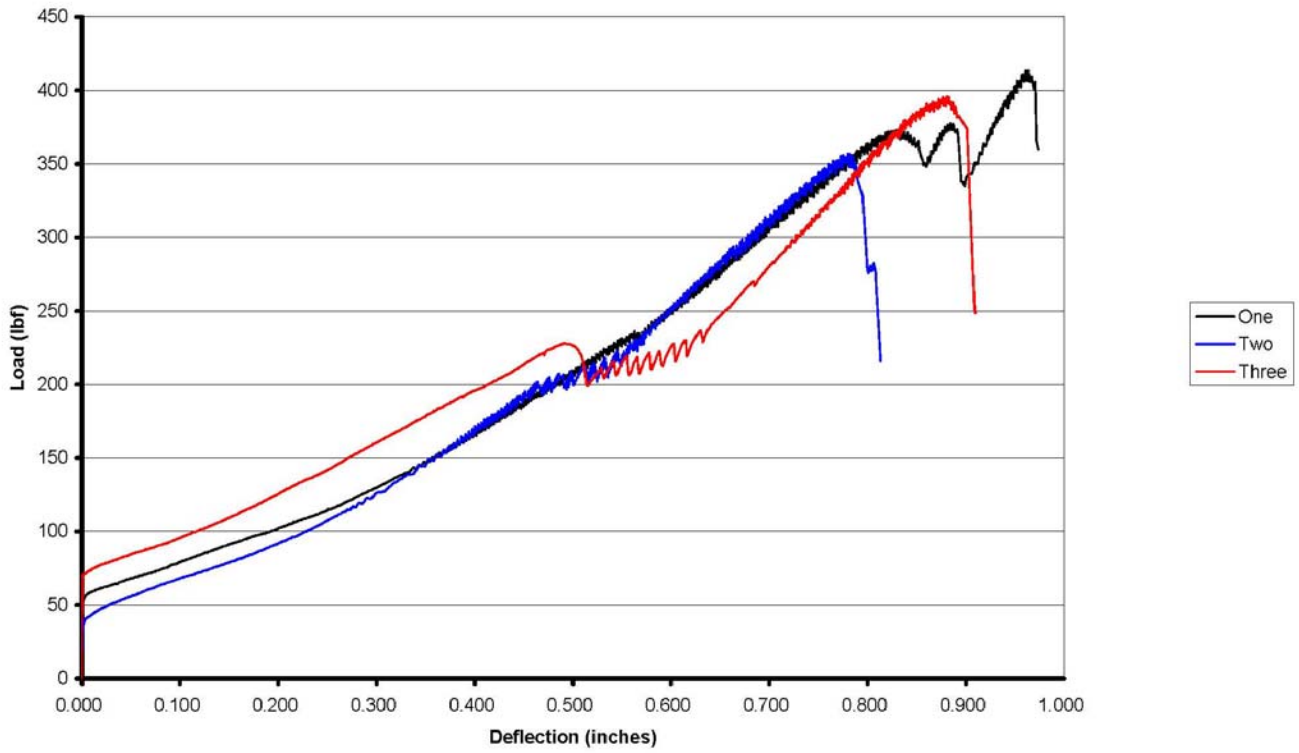

21 of 86

Progressive Engineering Inc.

ASTM D1761 Shear Testing

Date: 1/26/2010
Client: Newport Ventures, Inc.
Test: ASTM D1761 Shear Testing
Specimen Assembly No.: 3.1-(b5)

Project No.: 2009-1407
Temp.: 66.0 °F
Humidity: 24% R.H.
Load Rate: .2" per minute

Specimen Construction

Furring: Steel Hat Channel (33 mil)	Fastener: (2) #10 x 5" bugle-head screws, Item B10500SDRG
Foam: 2" EPS	Furring Pre-drill: 3/16" dia.
Sheathing: N/A	Remaining Material Pre-drill: 3/32" dia.
Stud: Steel (54 mil)	

Test Results

Sample	Maximum Load (lbf)	Deflection at Max. Load	Load (lbf) at:				*Connection Yield Mode
			.015" Defl.	.125" Defl.	.250" Defl.	.375" Defl.	
1	2012	1.686"	120	182	235	295	I _M
2	1884	1.613"	141	196	258	331	I _M
3	1889	1.557"	152	198	255	317	I _M
Average	1928	1.619"	138	192	249	314	
COV	4%	4%	12%	5%	5%	6%	

*Based on Single Shear Connection in Figure 1 of the AF&PA, NDS, Technical Report 12.

22 of 86



Specimen Construction



Typical Test Set-up



Typical Failure

Progressive Engineering Inc.

Newport Ventures, Inc.
Shear Test on Assembly 3.1-(b5) (2" Foam)
Load vs Deflection

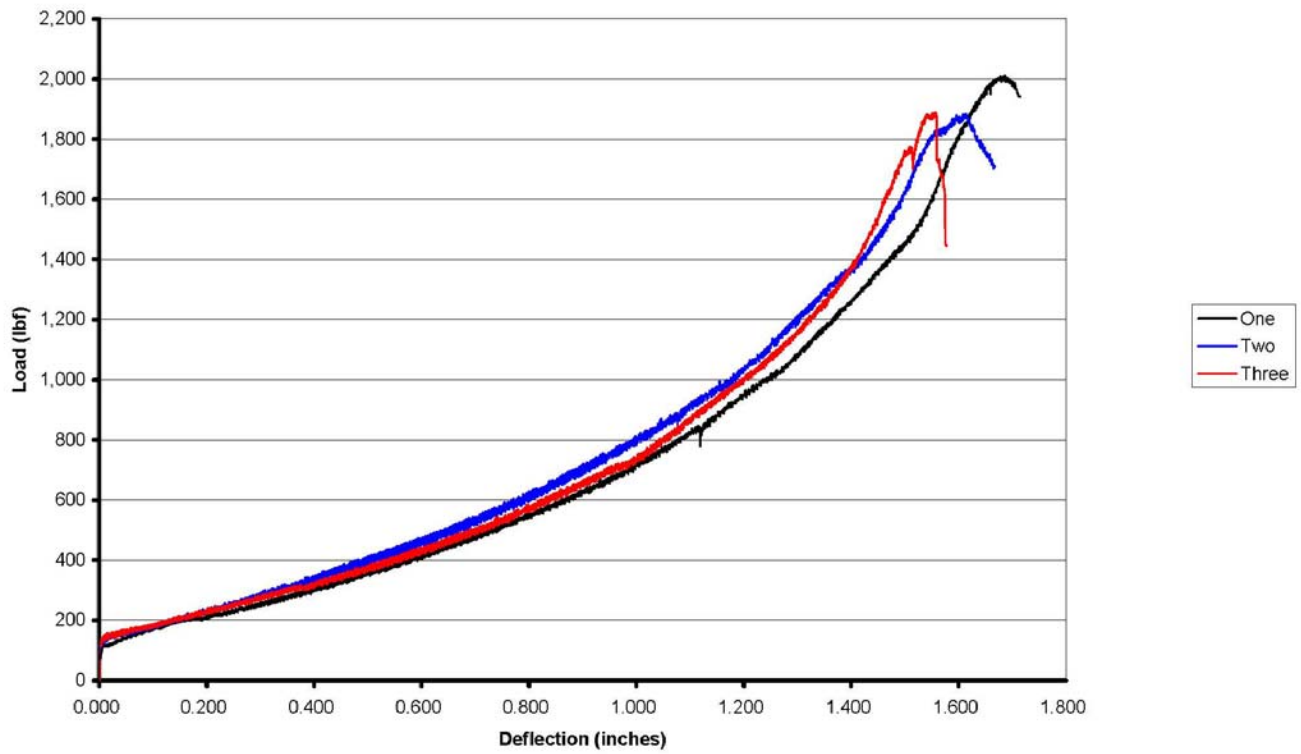

23 of 86

Progressive Engineering Inc.

ASTM D1761 Shear Testing

Date: 1/19/2010
Client: Newport Ventures, Inc.
Test: ASTM D1761 Shear Testing
Specimen Assembly No.: 3.2-(a1-1)

Project No.: 2009-1407
Temp.: 70.0 °F
Humidity: 21% R.H.
Load Rate: .2" per minute

Specimen Construction

Furring: 3/4" Wood	Fastener: (2) #8 x 3" standard wood screws
Foam: 1" EPS	Furring Predrill: 1/16" dia.
Sheathing: 7/16" OSB	Remaining Material Predrill: 1/16" dia.
Stud: N/A	

Test Results

Sample	Maximum Load (lbf)	Deflection at Max. Load	Load (lbf) at:				*Connection Yield Mode
			.015" Defl.	.125" Defl.	.250" Defl.	.375" Defl.	
1	398	.367"	158	280	368	398	III _M
2	308	.536"	112	200	248	299	III _M
3	447	.487"	138	251	337	395	III _M
Average	384	.463"	136	244	318	364	
COV	18%	19%	17%	17%	20%	15%	

*Based on Single Shear Connection in Figure 1 of the AF&PA, NDS, Technical Report 12.

24 of 86



Specimen Construction



Typical Test Set-up



Typical Failure

Progressive Engineering Inc.

Newport Ventures, Inc.
Shear Test on Assembly 3.2-(a1-1) (1" Foam)
Load vs Deflection

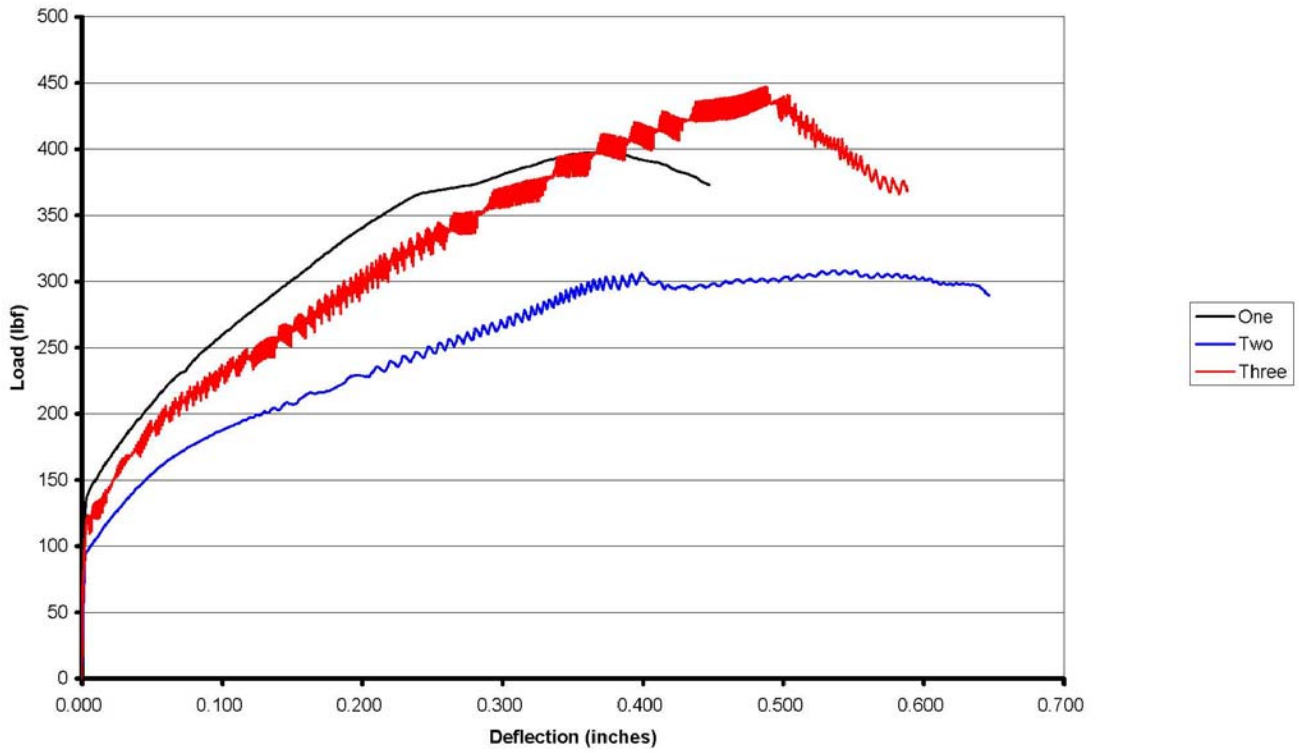

25 of 86

Progressive Engineering Inc.

ASTM D1761 Shear Testing

Date: 1/25/2010
Client: Newport Ventures, Inc.
Test: ASTM D1761 Shear Testing (Long Term Loading)
Specimen Assembly No.: 3.2-(a1-2)

Project No.: 2009-1407
Temp.: 70.0 °F
Humidity: 24% R.H.
Load Rate: NA

Specimen Construction

Furring: 3/4" Wood	Fastener: (2) #8 x 3" standard wood screws
Foam: 1" EPS	Furring Predrill: 1/16" dia.
Sheathing: 7/16" OSB	Remaining Material Predrill: 1/16" dia.
Stud: N/A	

Test Results

Sample	Applied Load (lbs)	Deflection at 1 Day	Deflection at 1 Week	Deflection at 1 Month
1	104.3	.008"	.018"	.029"

26 of 86



Specimen Construction



Typical Test Set-up

Newport Ventures, Inc.
Duration of Load Test on Assembly 3.2-(a1-2)
Deflection vs Time

Part 3.2 a1-2 (104.3 Pounds)

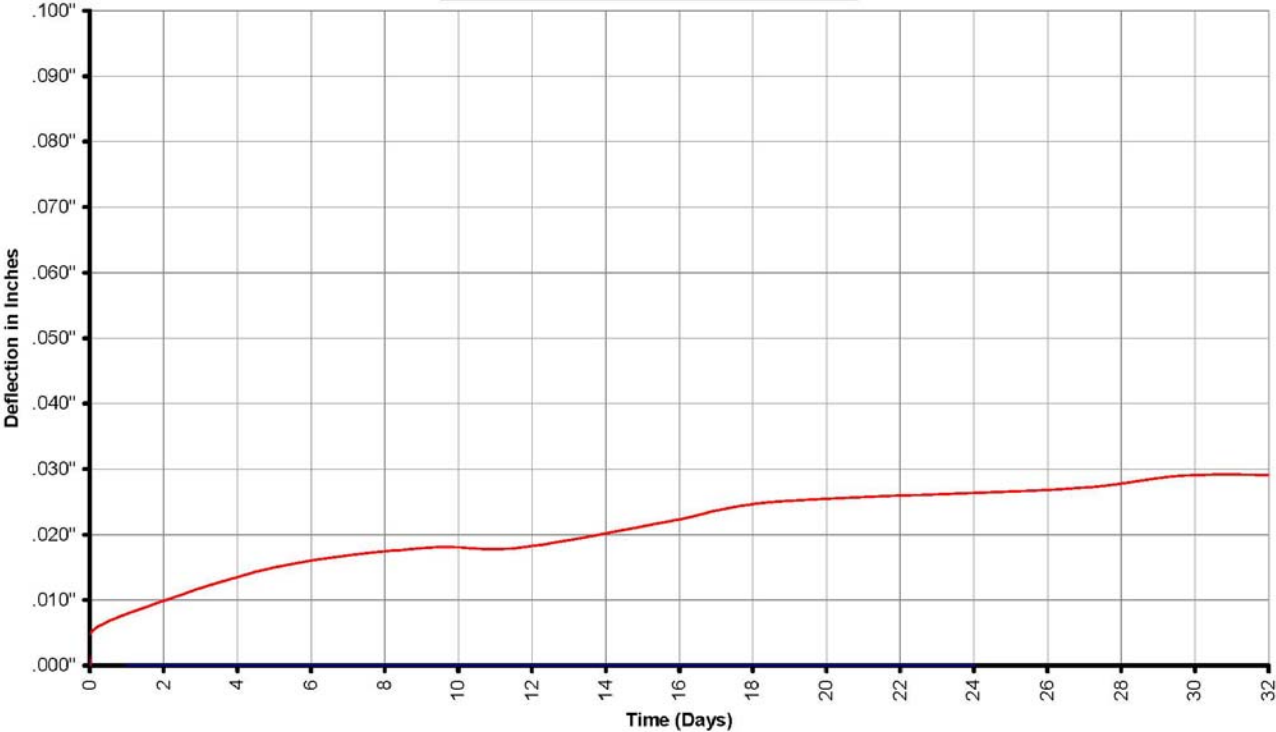

27 of 86

Progressive Engineering Inc.

ASTM D1761 Shear Testing

Date: 12/28/2009
Client: Newport Ventures, Inc.
Test: ASTM D1761 Shear Testing
Specimen Assembly No.: **3.2-(a1-3)**

Project No.: 2009-1407
Temp.: 70.0 °F
Humidity: 21% R.H.
Load Rate: .2" per minute

Specimen Construction

Furring: 3/8" Wood	Fastener: (2) 7d box nails (.099" x 2-1/4") bright, smooth
Foam: 1" EPS	Furring Predrill: N/A
Sheathing: 7/16" OSB	Remaining Material Predrill: N/A
Stud: N/A	

Test Results

Sample	Maximum Load (lbf)	Deflection at Max. Load	Load (lbf) at:				*Connection Yield Mode	*Based on Single Shear Connection in Figure 1 of the AF&PA, NDS, Technical Report 12.
			.015" Defl.	.125" Defl.	.250" Defl.	.375" Defl.		
1	144	.898"	49	86	107	124	III _M	

28 of 86



Specimen Construction



Typical Test Set-up



Typical Failure

Progressive Engineering Inc.

Newport Ventures, Inc.
Shear Test on Assembly 3.2-(a1-3) (1" Foam)
Load vs Deflection

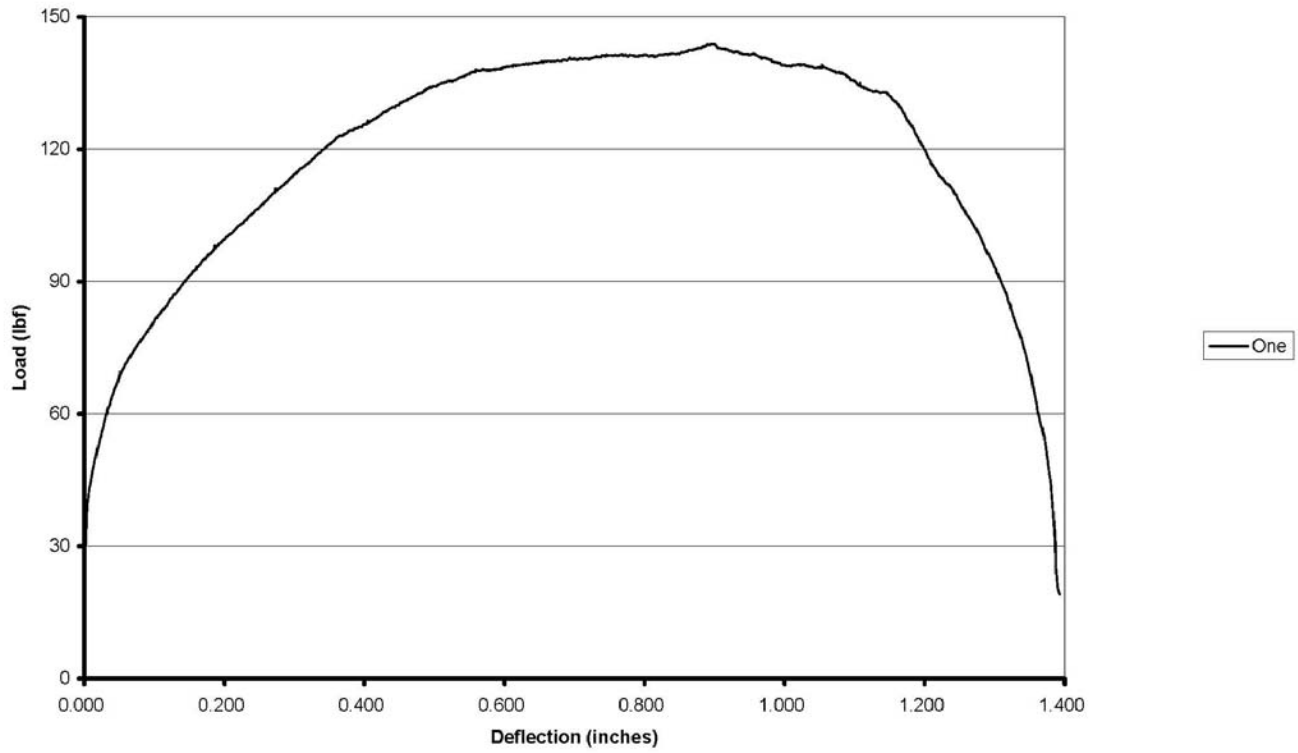

29 of 86

Progressive Engineering Inc.

ASTM D1761 Shear Testing

Date: 1/21/2010
Client: Newport Ventures, Inc.
Test: ASTM D1761 Shear Testing
Specimen Assembly No.: 3.2-(a1-4)

Project No.: 2009-1407
Temp.: 70.0 °F
Humidity: 23% R.H.
Load Rate: .2" per minute

Specimen Construction

Furring: 3/4" Wood	Fastener: (2) #8 x 1-1/2" standard wood screws
Foam: N/A	Furring Predrill: 3/32" dia.
Sheathing: 7/16" OSB	Remaining Material Predrill: 3/32" dia.
Stud: N/A	

Test Results

Sample	Maximum Load (lbf)	Deflection at Max. Load	Load (lbf) at:				*Connection Yield Mode
			.015" Defl.	.125" Defl.	.250" Defl.	.375" Defl.	
1	575	.209"	415	516	575	575	III _M
2	784	.343"	351	566	764	784	III _M
3	556	.336"	292	444	527	556	III _M
Average	638	.296"	353	509	622	638	
COV	20%	25%	17%	12%	20%	20%	

*Based on Single Shear Connection in Figure 1 of the AF&PA, NDS, Technical Report 12.

30 of 86



Specimen Construction



Typical Test Set-up



Typical Failure

Newport Ventures, Inc.
Shear Test on Assembly 3.2-(a1-4) (No Foam)
Load vs Deflection

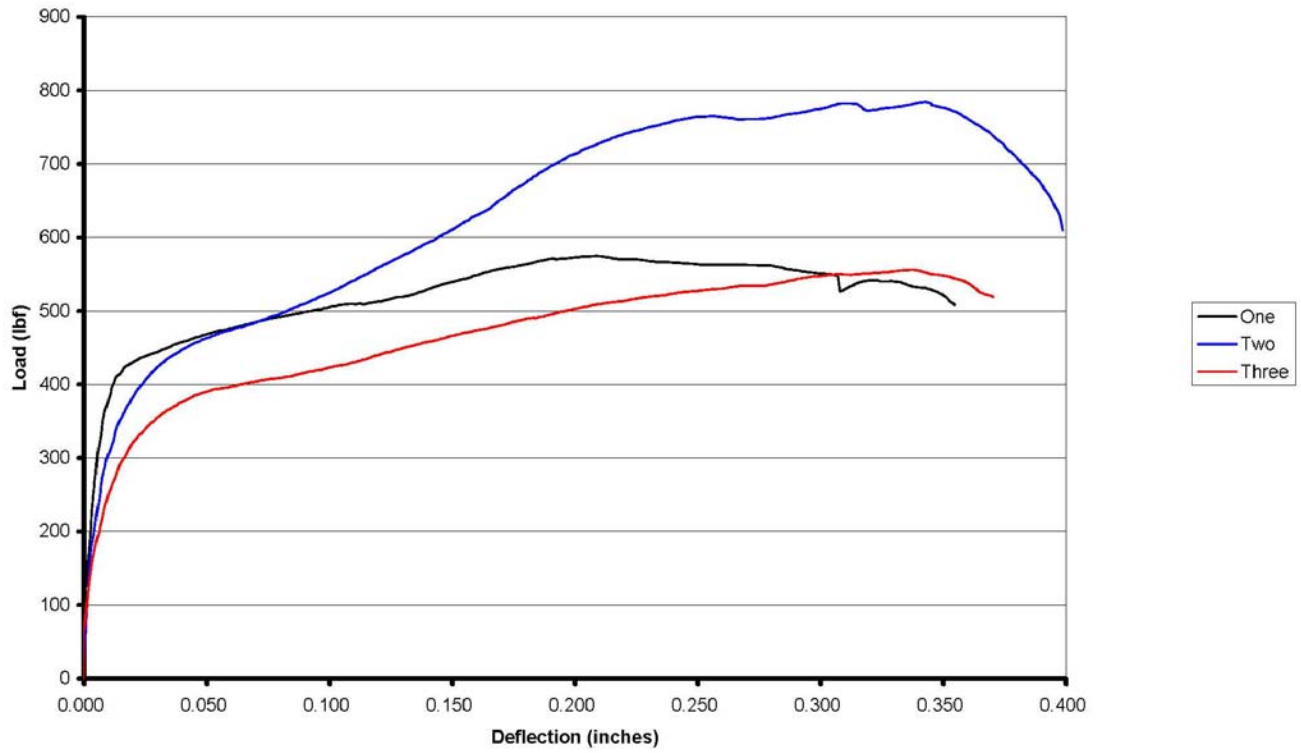

31 of 86

Progressive Engineering Inc.

ASTM D1761 Shear Testing

Date: 1/19/2010
Client: Newport Ventures, Inc.
Test: ASTM D1761 Shear Testing
Specimen Assembly No.: 3.2-(a2-1)

Project No.: 2009-1407
Temp.: 70.0 °F
Humidity: 21% R.H.
Load Rate: .2" per minute

Specimen Construction

Furring: 3/4" Wood	Fastener: (2) 1/4" x 6" lag screws
Foam: 4" EPS	Furring Pre-drill: 1/8" dia.
Sheathing: 3/4" OSB	Remaining Material Pre-drill: 15/64" dia.
Stud: N/A	

Test Results

Sample	Maximum Load (lbf)	Deflection at Max. Load	Load (lbf) at:				*Connection Yield Mode
			.015" Defl.	.125" Defl.	.250" Defl.	.375" Defl.	
1	711	1.212"	174	265	333	381	III _M
2	761	1.793"	115	146	183	230	III _M
3	592	1.305"	180	247	283	328	III _M
Average	688	1.437"	156	219	266	313	
COV	13%	22%	23%	29%	29%	24%	

*Based on Single Shear Connection in Figure 1 of the AF&PA, NDS, Technical Report 12.

32 of 86



Specimen Construction



Typical Test Set-up



Typical Failure

Newport Ventures, Inc.
Shear Test on Assembly 3.2-(a2-1) (4" Foam)
Load vs Deflection

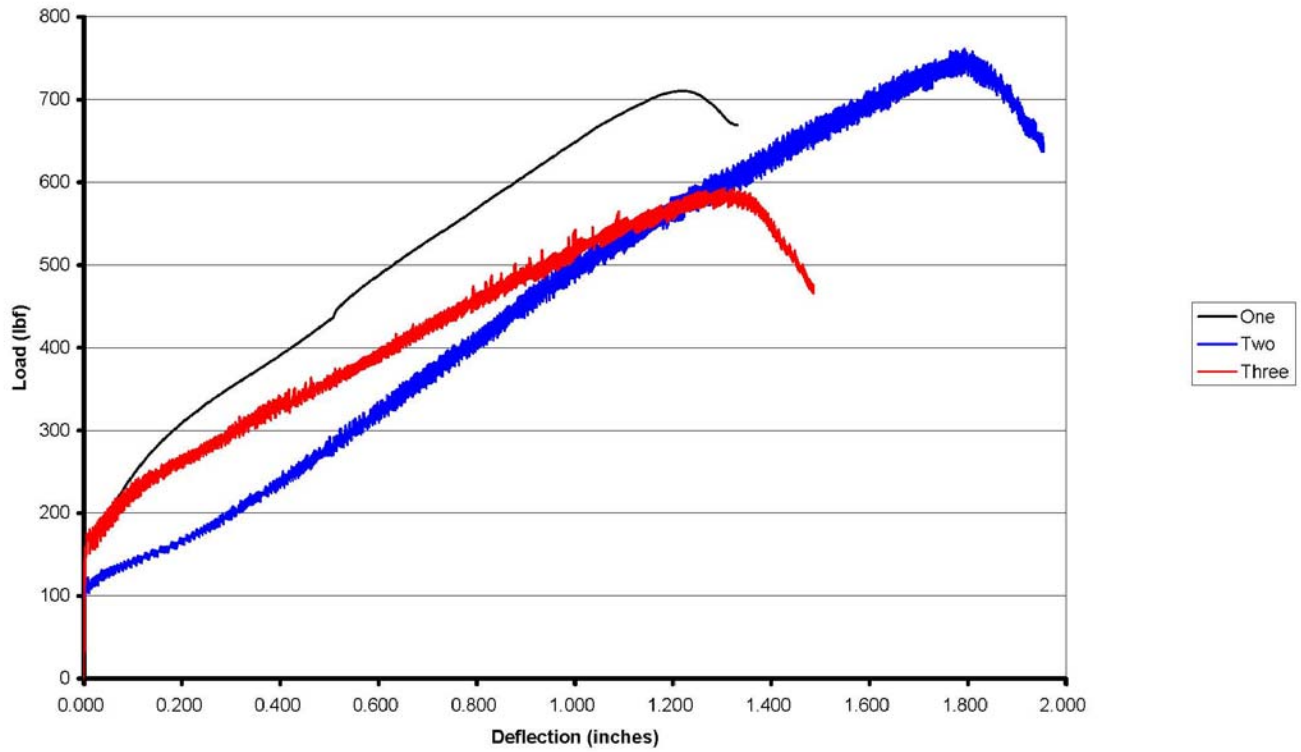

33 of 86

Progressive Engineering Inc.

ASTM D1761 Shear Testing

Date: 1/25/2010
Client: Newport Ventures, Inc.
Test: ASTM D1761 Shear Testing (Long Term Loading)
Specimen Assembly No.: 3.2-(a2-2)

Project No.: 2009-1407
Temp.: 70.0 °F
Humidity: 24% R.H.
Load Rate: .2" per minute

Specimen Construction

Furring: 3/4" Wood	Fastener: (2) 1/4" x 6" lag screws
Foam: 4" EPS	Furring Pre-drill: 1/8" dia.
Sheathing: 3/4" OSB	Remaining Material Pre-drill: 15/64" dia.
Stud: N/A	

Test Results

Sample	Applied Load (lbs)	Deflection at 1 Day	Deflection at 1 Week	Deflection at 1 Month
1	126.5	.029"	.115"	.167"

34 of 86



Specimen Construction



Typical Test Set-up

Newport Ventures, Inc.
Duration of Load Test on Assembly 3.2-(a2-2)
Deflection vs Time

Part 3.2 a2-2 (126.5 Pounds)

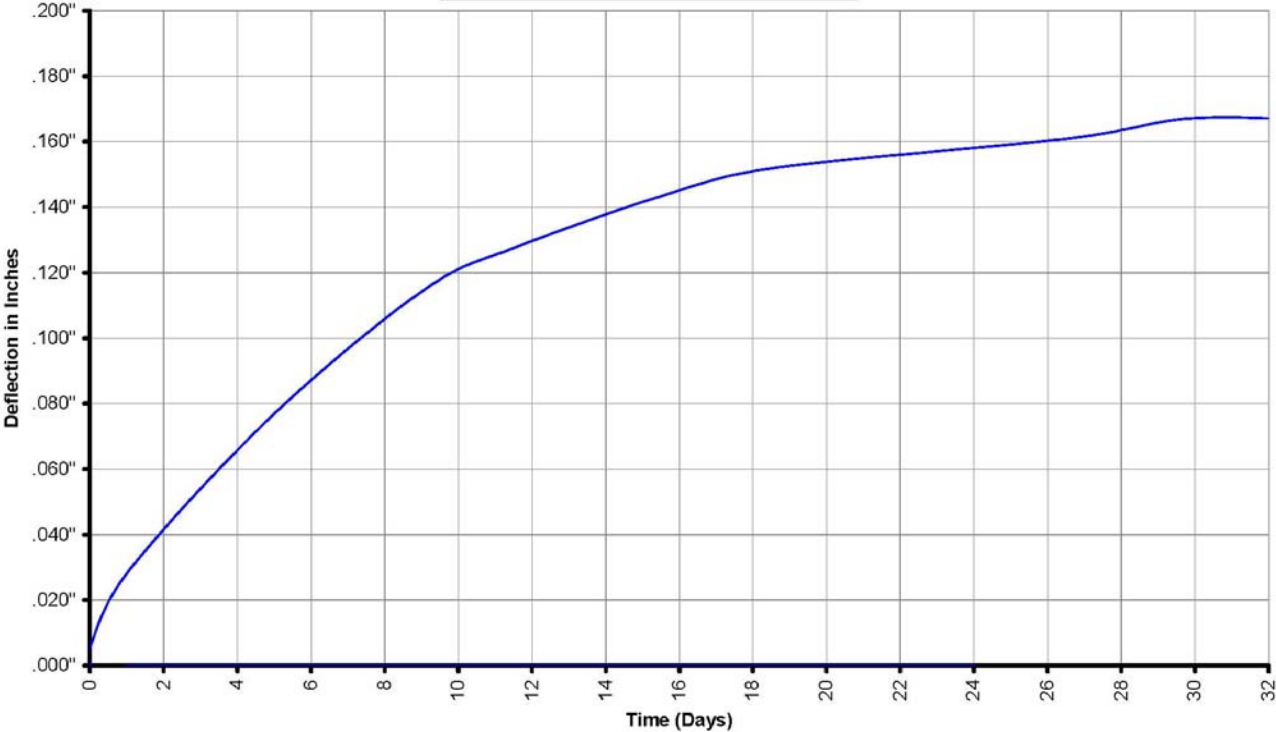

35 of 88

Progressive Engineering Inc.

ASTM D1761 Shear Testing

Date: 12/29/2009
Client: Newport Ventures, Inc.
Test: ASTM D1761 Shear Testing
Specimen Assembly No.: 3.2-(a2-3)

Project No.: 2009-1407
Temp.: 70.0 °F
Humidity: 21% R.H.
Load Rate: .2" per minute

Specimen Construction

Furring: 3/4" Wood	Fastener: (2) .135" (10g) x 6" Foundry nails
Foam: 4" EPS	Furring Pre-drill: N/A
Sheathing: 3/4" OSB	Remaining Material Pre-drill: N/A
Stud: N/A	

Test Results

Sample	Maximum Load (lbf)	Deflection at Max. Load	Load (lbf) at:				*Connection Yield Mode
			.015" Defl.	.125" Defl.	.250" Defl.	.375" Defl.	
1	325	2.863"	83	115	146	145	IV

*Based on Single Shear Connection in Figure 1 of the AF&PA, NDS, Technical Report 12.

36 of 86



Specimen Construction



Typical Test Set-up



Typical Failure

Progressive Engineering Inc.

Newport Ventures, Inc.
Shear Test on Assembly 3.2-(a2-3) (4" Foam)
Load vs Deflection

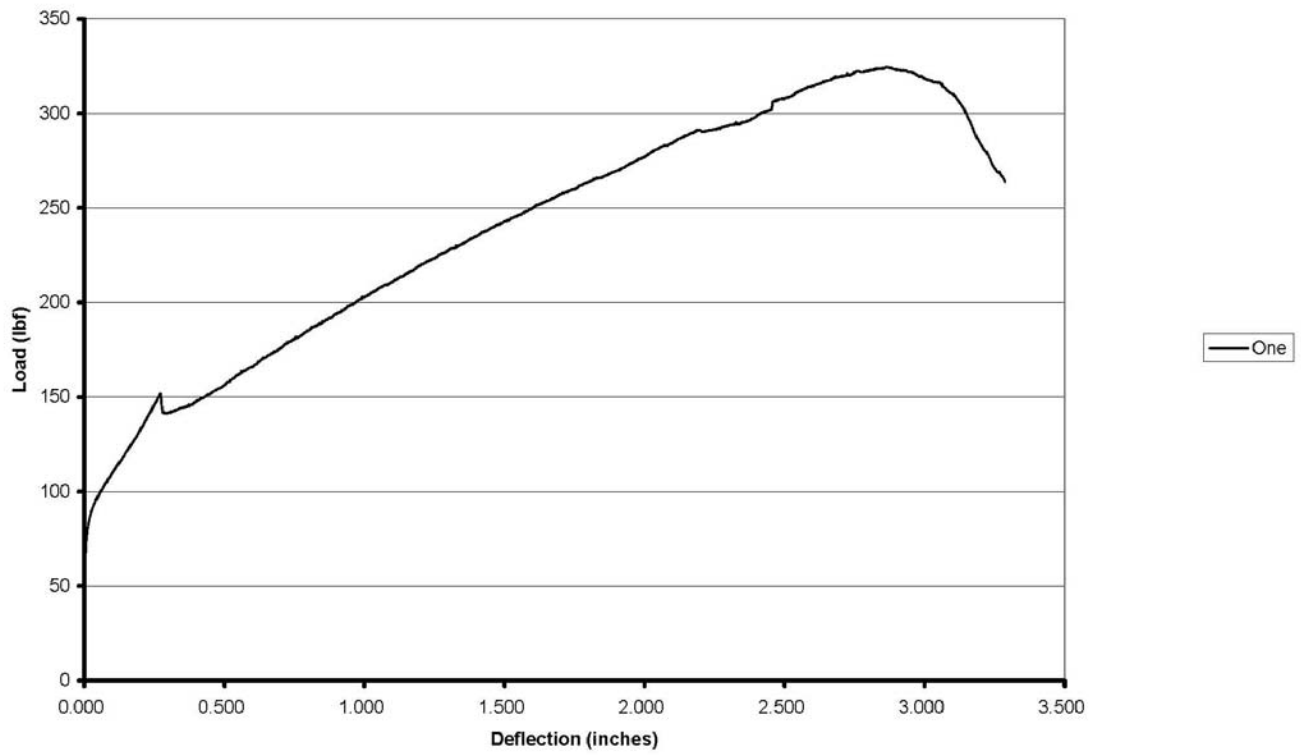

37 of 86

Progressive Engineering Inc.

ASTM D1761 Shear Testing

Date: 1/19/2010
Client: Newport Ventures, Inc.
Test: ASTM D1761 Shear Testing
Specimen Assembly No.: 3.2-(a2-4)

Project No.: 2009-1407
Temp.: 70.0 °F
Humidity: 21% R.H.
Load Rate: .2" per minute

Specimen Construction

Furring: 3/4" Wood	Fastener: (2) 1/4" x 2" lag screws
Foam: N/A	Furring Predrill: 15/64" dia.
Sheathing: 3/4" OSB	Remaining Material Predrill: 1/8" dia.
Stud: N/A	

Test Results

Sample	Maximum Load (lbf)	Deflection at Max. Load	Load (lbf) at:				*Connection Yield Mode
			.015" Defl.	.125" Defl.	.250" Defl.	.375" Defl.	
1	1740	.752"	370	977	1210	1440	II
2	1775	.520"	463	1145	1379	1588	II
3	1369	.766"	365	871	1075	1188	II
Average	1628	.679"	399	998	1221	1405	
COV	14%	20%	14%	14%	12%	14%	

*Based on Single Shear Connection in Figure 1 of the AF&PA, NDS, Technical Report 12.

38 of 86



Specimen Construction



Typical Test Set-up



Typical Failure

Newport Ventures, Inc.
Shear Test on Assembly 3.2-(a2-4) (No Foam)
Load vs Deflection

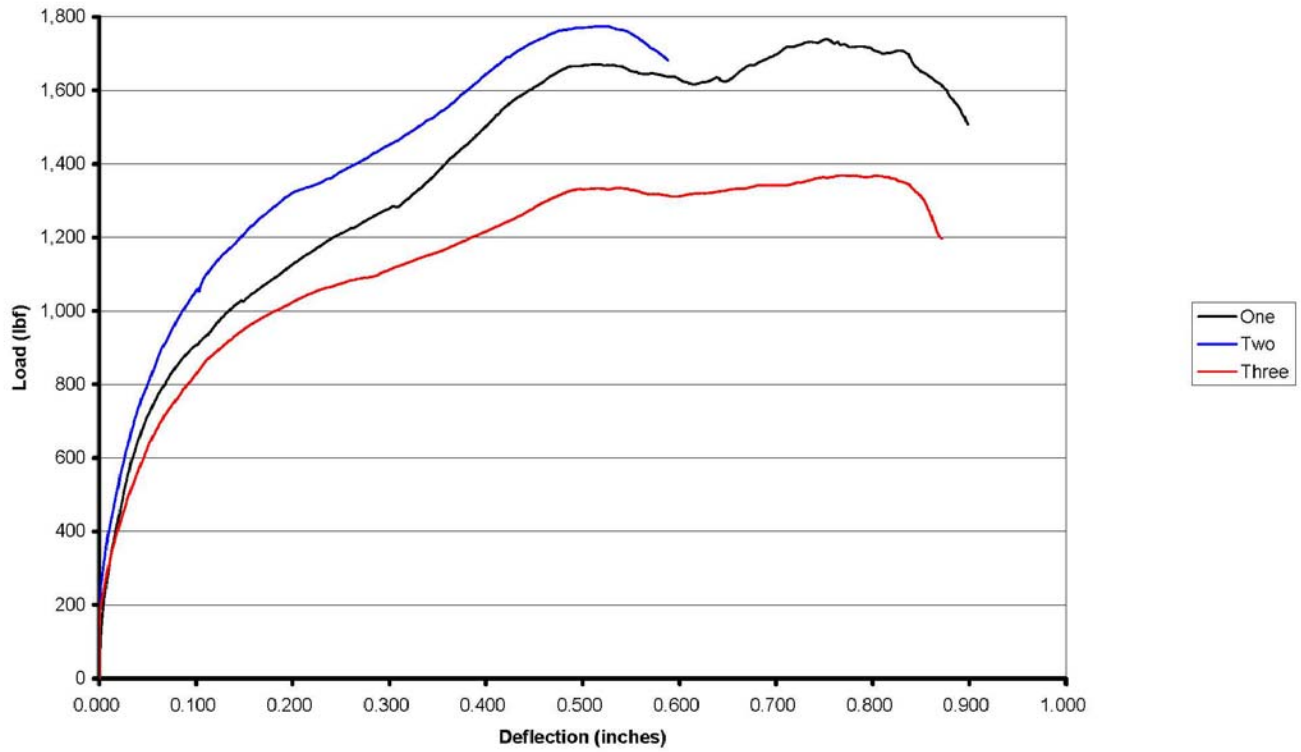

39 of 86

Progressive Engineering Inc.

ASTM D1761 Shear Testing

Date: 1/21/2010
Client: Newport Ventures, Inc.
Test: ASTM D1761 Shear Testing
Specimen Assembly No.: 3.2-(a2-5)

Project No.: 2009-1407
Temp.: 70.0 °F
Humidity: 23% R.H.
Load Rate: .2" per minute

Specimen Construction

Furring: 3/4" Wood	Fastener: (2) 1/4" x 4" lag screws
Foam: 2" EPS	Furring Pre-drill: 15/64" dia.
Sheathing: 3/4" OSB	Remaining Material Pre-drill: 1/8" dia.
Stud: N/A	

Test Results

Sample	Maximum Load (lbf)	Deflection at Max. Load	Load (lbf) at:				*Connection Yield Mode
			.015" Defl.	.125" Defl.	.250" Defl.	.375" Defl.	
1	888	1.235"	133	269	380	447	II
2	804	.876"	202	354	497	582	II
3	818	.852"	259	429	551	639	II
Average	837	.988"	198	351	476	556	
COV	5%	22%	32%	23%	18%	18%	

*Based on Single Shear Connection in Figure 1 of the AF&PA, NDS, Technical Report 12.

40 of 86



Specimen Construction



Typical Test Set-up



Typical Failure

Newport Ventures, Inc.
Shear Test on Assembly 3.2-(a2-5) (2" Foam)
Load vs Deflection

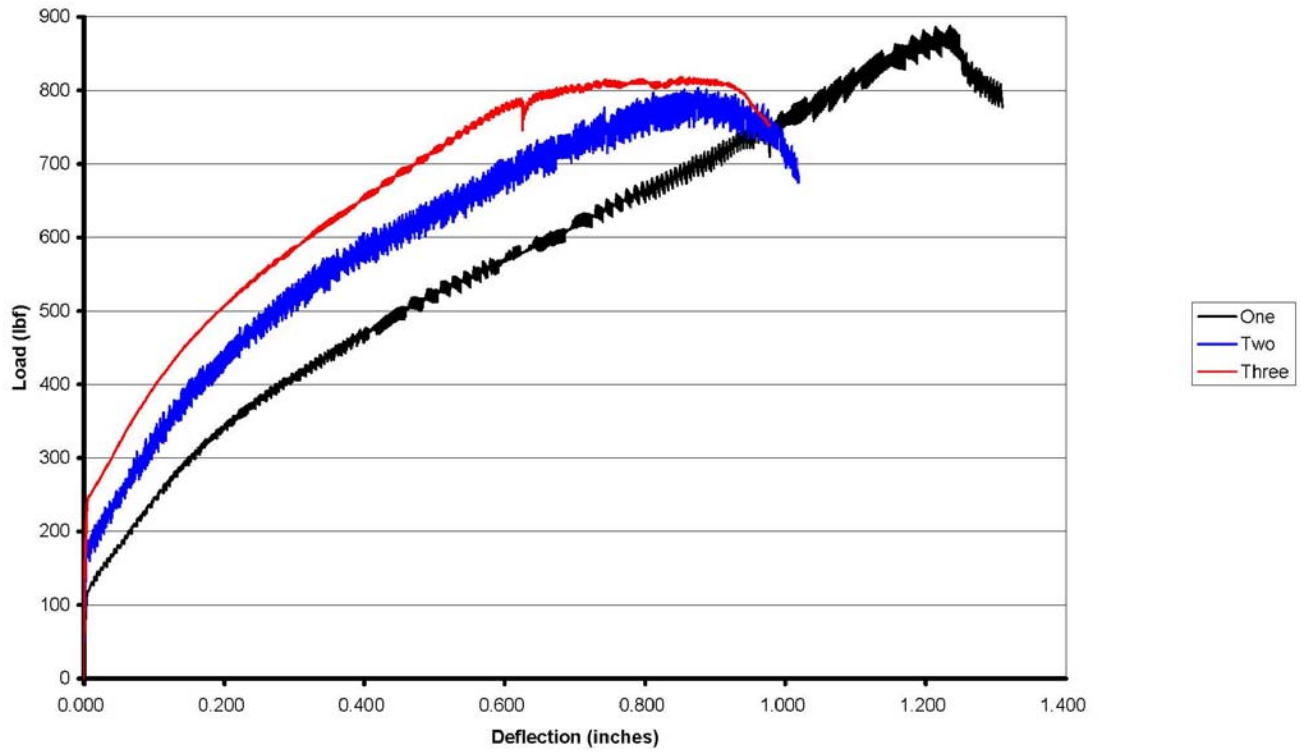

41 of 86

Progressive Engineering Inc.

ASTM D1761 Shear Testing

Date: 1/25/2010
Client: Newport Ventures, Inc.
Test: ASTM D1761 Shear Testing
Specimen Assembly No.: **3.2-(b1-1)**

Project No.: 2009-1407
Temp.: 70.0 °F
Humidity: 21% R.H.
Load Rate: .2" per minute

Specimen Construction

Furring: 3/4" Wood	Fastener: (2) #8 x 2-3/8" bugle-head screws, Item 30SRG
Foam: 1" EPS	Furring Predrill: 3/32" dia.
Sheathing: N/A	Remaining Material Predrill: 1/16" dia.
Stud: Steel (33 mil)	

Test Results

Sample	Maximum Load (lbf)	Deflection at Max. Load	Load (lbf) at:				*Connection Yield Mode
			.015" Defl.	.125" Defl.	.250" Defl.	.375" Defl.	
1	297	.295"	64	163	260	297	III _M
2	402	.528"	96	217	269	362	III _M
3	351	.338"	109	212	293	351	III _M
Average	350	.387"	90	197	274	337	
COV	15%	32%	26%	15%	6%	10%	

*Based on Single Shear Connection in Figure 1 of the AF&PA, NDS, Technical Report 12.

42 of 86



Specimen Construction

Similar to other set-ups. No picture available.

Typical Test Set-up



Typical Failure

Progressive Engineering Inc.

Newport Ventures, Inc.
Shear Test on Assembly 3.2-(b1-1) (1" Foam)
Load vs Deflection

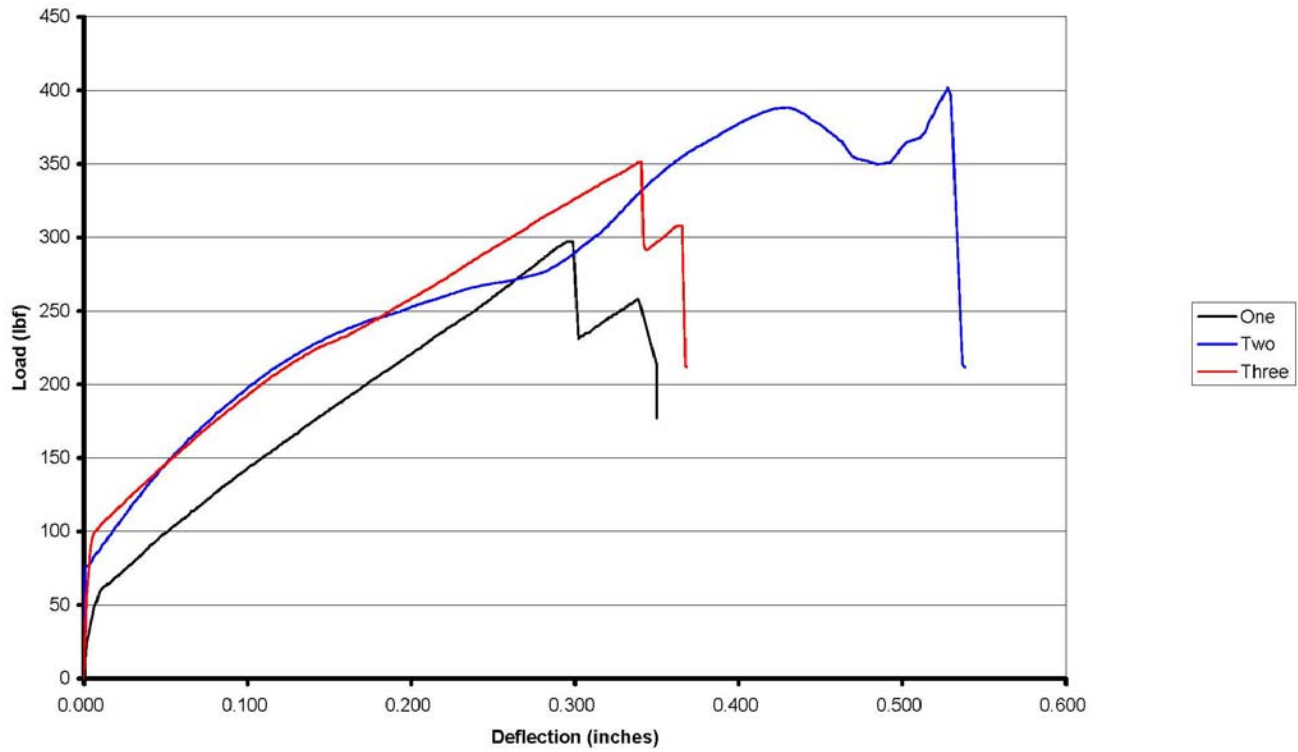

43 of 86

Progressive Engineering Inc.

ASTM D1761 Shear Testing

Date: 2/25/2010
Client: Newport Ventures, Inc.
Test: ASTM D1761 Shear Testing (Long Term Loading)
Specimen Assembly No.: 3.2-(b1-2)

Project No.: 2009-1407
Temp.: 62.6 °F
Humidity: 34.6% R.H.
Load Rate: NA

Specimen Construction

Furring: 3/4" Wood	Fastener: (2) #8 x 2-3/8" bugle-head screws, Item 30SRG
Foam: 1" EPS	Furring Predrill: 3/32" dia.
Sheathing: NA	Remaining Material Predrill: 1/16" dia.
Stud: Steel (33 mil)	

Test Results

Sample	Applied Load (lbs)	Deflection at 1 Day	Deflection at 1 Week	Deflection at 1 Month
1	60	.033"	.034"	*

* After several days without increased deflection, the testing was discontinued (see graph for details).



Typical Test Set-up



Typical Test Set-up

**Newport Ventures, Inc.
Duration of Load Test on Assembly 3.2-(b1-2)
Deflection vs. Time**

— Part 3.2-b1-2 (60 Pounds)

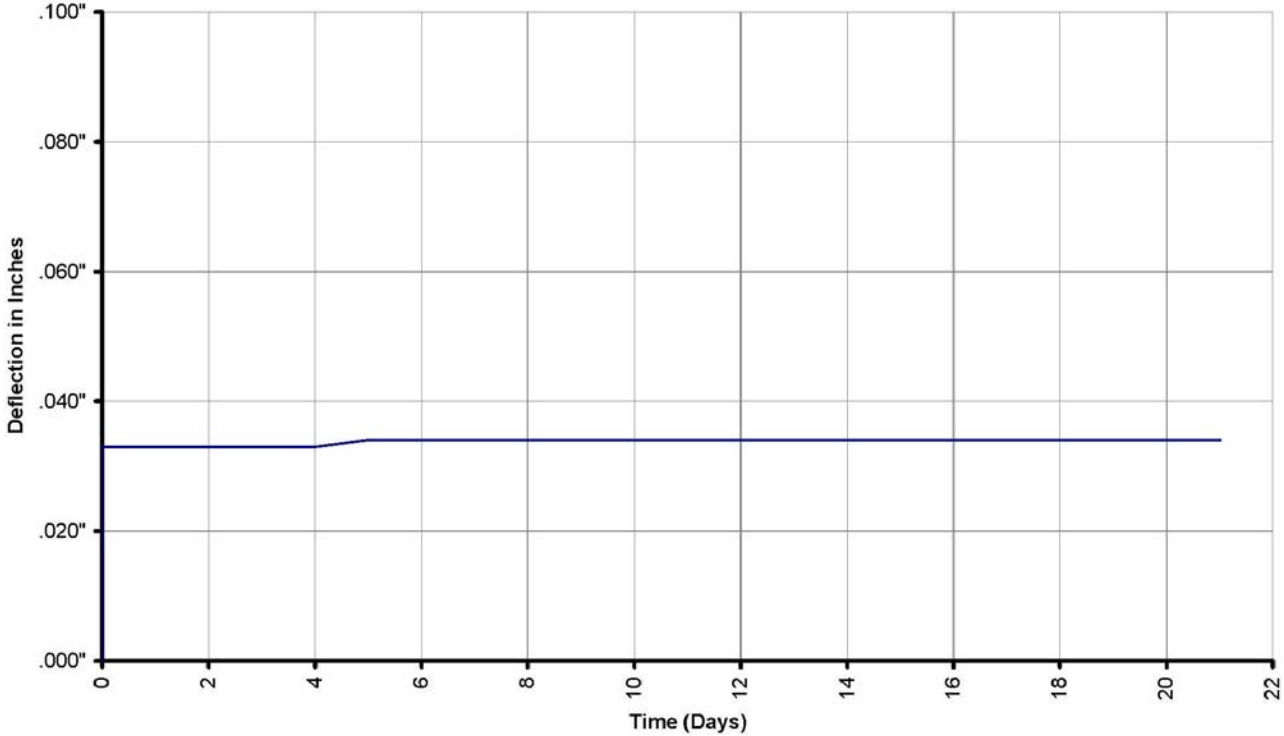

45 of 86

Progressive Engineering Inc.

ASTM D1761 Shear Testing

Date: 1/26/2010
Client: Newport Ventures, Inc.
Test: ASTM D1761 Shear Testing
Specimen Assembly No.: 3.2-(b1-3)

Project No.: 2009-1407
Temp.: 66.0 °F
Humidity: 24% R.H.
Load Rate: .2" per minute

Specimen Construction

Furring: 3/4" Wood (reduced to 3/8")	Fastener: (2) #8 x 2-3/8" bugle-head screws, Item 30SRG
Foam: 1" EPS	Furring Pre-drill: 3/32" dia.
Sheathing: N/A	Remaining Material Pre-drill: 1/16" dia.
Stud: Steel (33 mil)	

Test Results

Sample	Maximum Load (lbf)	Deflection at Max. Load	Load (lbf) at:				*Connection Yield Mode
			.015" Defl.	.125" Defl.	.250" Defl.	.375" Defl.	
1	537	.792"	67	135	189	258	II
2	409	.647"	95	156	221	285	II
3	376	.543"	84	151	212	299	II
Average	441	.661"	82	147	207	281	
COV	19%	19%	17%	7%	8%	7%	

*Based on Single Shear Connection in Figure 1 of the AF&PA, NDS, Technical Report 12.

46 of 86



Specimen Construction



Typical Test Set-up

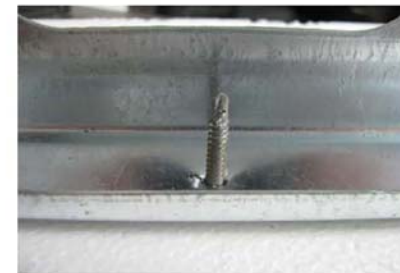

Typical Failure

Progressive Engineering Inc.

Newport Ventures, Inc.
Shear Test on Assembly 3.2-(b1-3) (1" Foam)
Load vs Deflection

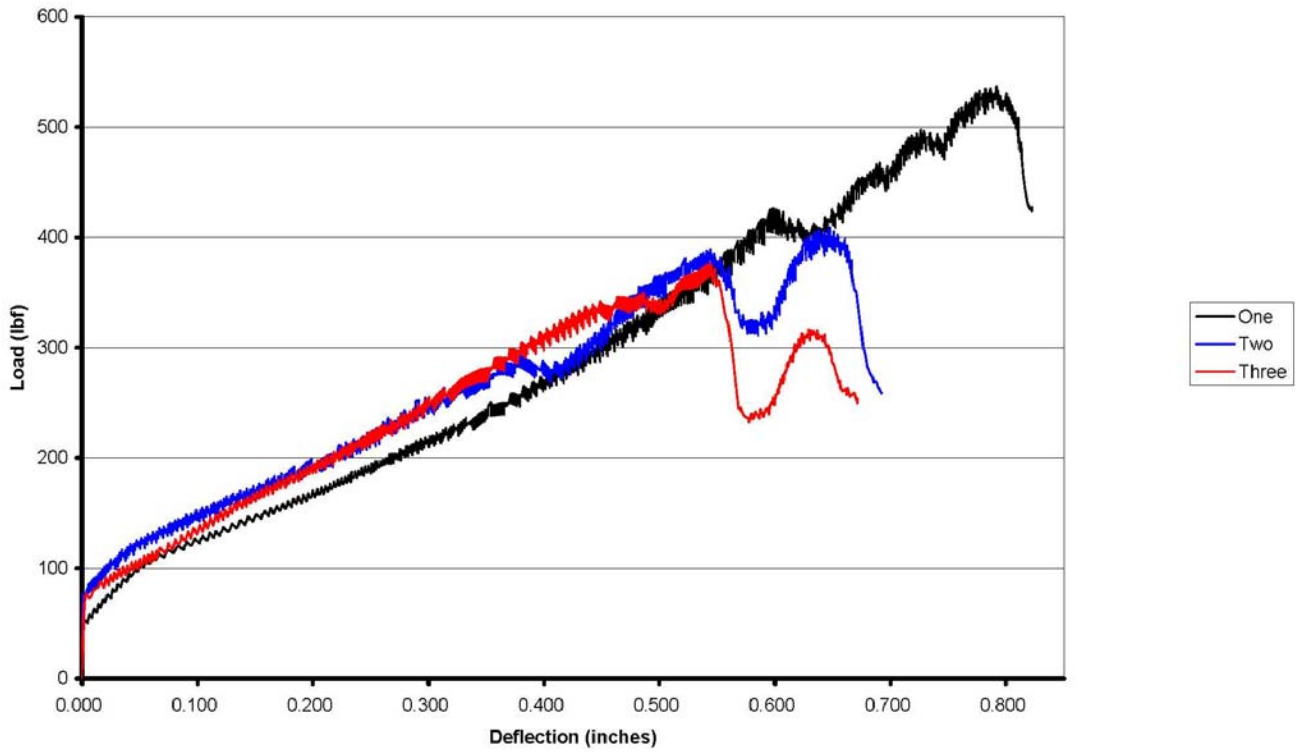

47 of 86

Progressive Engineering Inc.

ASTM D1761 Shear Testing

Date: 1/26/2010
Client: Newport Ventures, Inc.
Test: ASTM D1761 Shear Testing
Specimen Assembly No.: 3.2-(b1-4)

Project No.: 2009-1407
Temp.: 66.0 °F
Humidity: 24% R.H.
Load Rate: .2" per minute

Specimen Construction

Furring: 3/4" Wood	Fastener: (2) #8 x 2-3/8" bugle-head screws, Item 30SRG
Foam: N/A	Furring Predrill: 3/32" dia.
Sheathing: N/A	Remaining Material Predrill: 1/16" dia.
Stud: Steel (33 mil)	

Test Results

Sample	Maximum Load (lbf)	Deflection at Max. Load	Load (lbf) at:				*Connection Yield Mode
			.015" Defl.	.125" Defl.	.250" Defl.	.375" Defl.	
1	904	.773"	325	602	676	759	I _M
2	904	.381"	316	630	736	898	I _M
3	814	.349"	333	658	774	814	I _M
Average	874	.501"	325	630	729	824	
COV	6%	47%	3%	4%	7%	8%	

*Based on Single Shear Connection in Figure 1 of the AF&PA, NDS, Technical Report 12.

48 of 86



Specimen Construction



Typical Test Set-up

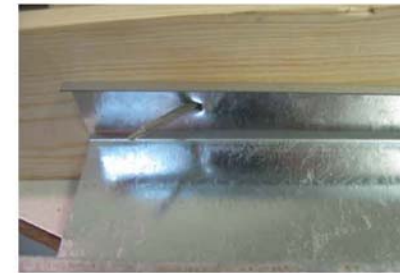

Typical Failure

Progressive Engineering Inc.

Newport Ventures, Inc.
Shear Test on Assembly 3.2-(b1-4) (No Foam)
Load vs Deflection

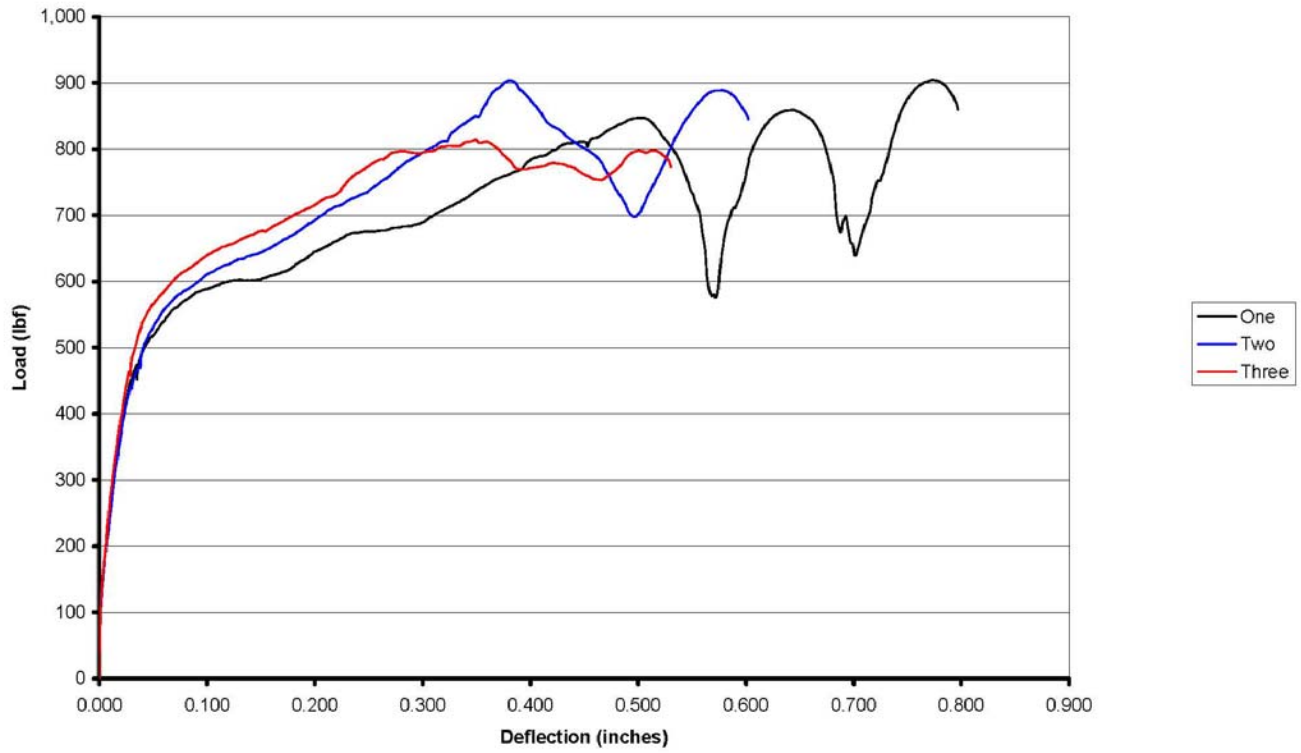

49 of 86

Progressive Engineering Inc.

ASTM D1761 Shear Testing

Date: 1/19/2010
Client: Newport Ventures, Inc.
Test: ASTM D1761 Shear Testing
Specimen Assembly No.: **3.2-(b1-5)**

Project No.: 2009-1407
Temp.: 70.0 °F
Humidity: 21% R.H.
Load Rate: .2" per minute

Specimen Construction

Furring: 3/4" Wood	Fastener: (2) #10 x 5" bugle-head screws, Item B10500SDRG
Foam: 2" EPS	Furring Pre-drill: 3/32" dia.
Sheathing: N/A	Remaining Material Pre-drill: 3/32" dia.
Stud: Steel (33 mil)	

Test Results

Sample	Maximum Load (lbf)	Deflection at Max. Load	Load (lbf) at:				*Connection Yield Mode
			.015" Defl.	.125" Defl.	.250" Defl.	.375" Defl.	
1	354	.807"	76	102	146	182	III _M
2	430	.837"	93	141	188	221	III _M
3	447	.957"	31	85	136	189	III _M
Average	410	.867"	67	109	157	197	
COV	12%	9%	48%	26%	18%	11%	

*Based on Single Shear Connection in Figure 1 of the AF&PA, NDS, Technical Report 12.

50 of 86



Specimen Construction



Typical Test Set-up



Typical Failure

Newport Ventures, Inc.
Shear Test on Assembly 3.2-(b1-5) (2" Foam)
Load vs Deflection

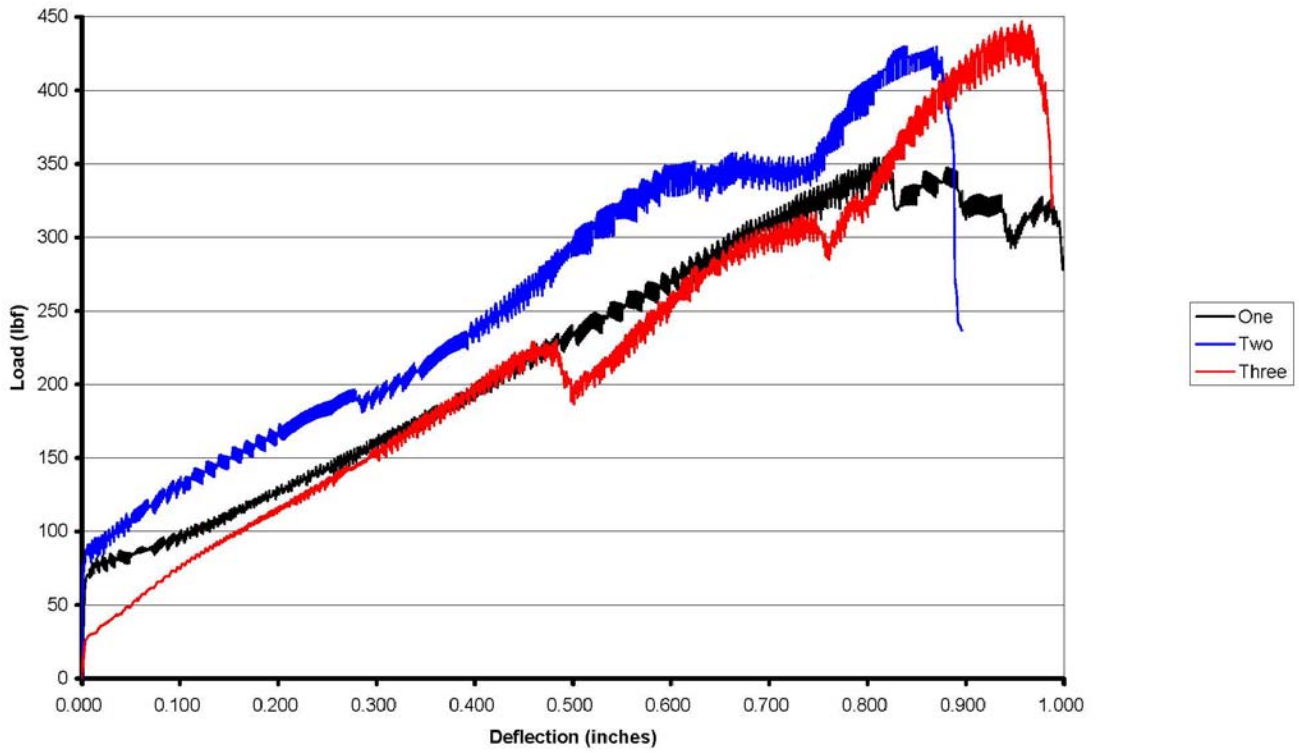

51 of 86

Progressive Engineering Inc.

ASTM D1761 Shear Testing

Date: 2/25/2010
Client: Newport Ventures, Inc.
Test: ASTM D1761 Shear Testing (Long Term Loading)
Specimen Assembly No.: 3.2-(b2-2)

Project No.: 2009-1407
Temp.: 62.6 °F
Humidity: 34.6% R.H.
Load Rate: NA

Specimen Construction

Furring: 3/4" Wood (reduced to 3/8")	Fastener: (2) #10 x 5" bugle-head screws, Item B10500SDRG
Foam: 4" EPS	Furring Predrill: 3/32" dia.
Sheathing: N/A	Remaining Material Predrill: 3/32" dia.
Stud: Steel (54 mil)	

Test Results

Sample	Applied Load (lbs)	Deflection at 1 Day	Deflection at 1 Week	Deflection at 1 Month
1	80	.006"	.006"	*

* After several days without increased deflection, the testing was discontinued (see graph for details).



Typical Test Set-up



Typical Test Set-up

52 of 86

Newport Ventures, Inc.
Duration of Load Test on Assembly 3.2-(b2-2)
Deflection vs. Time

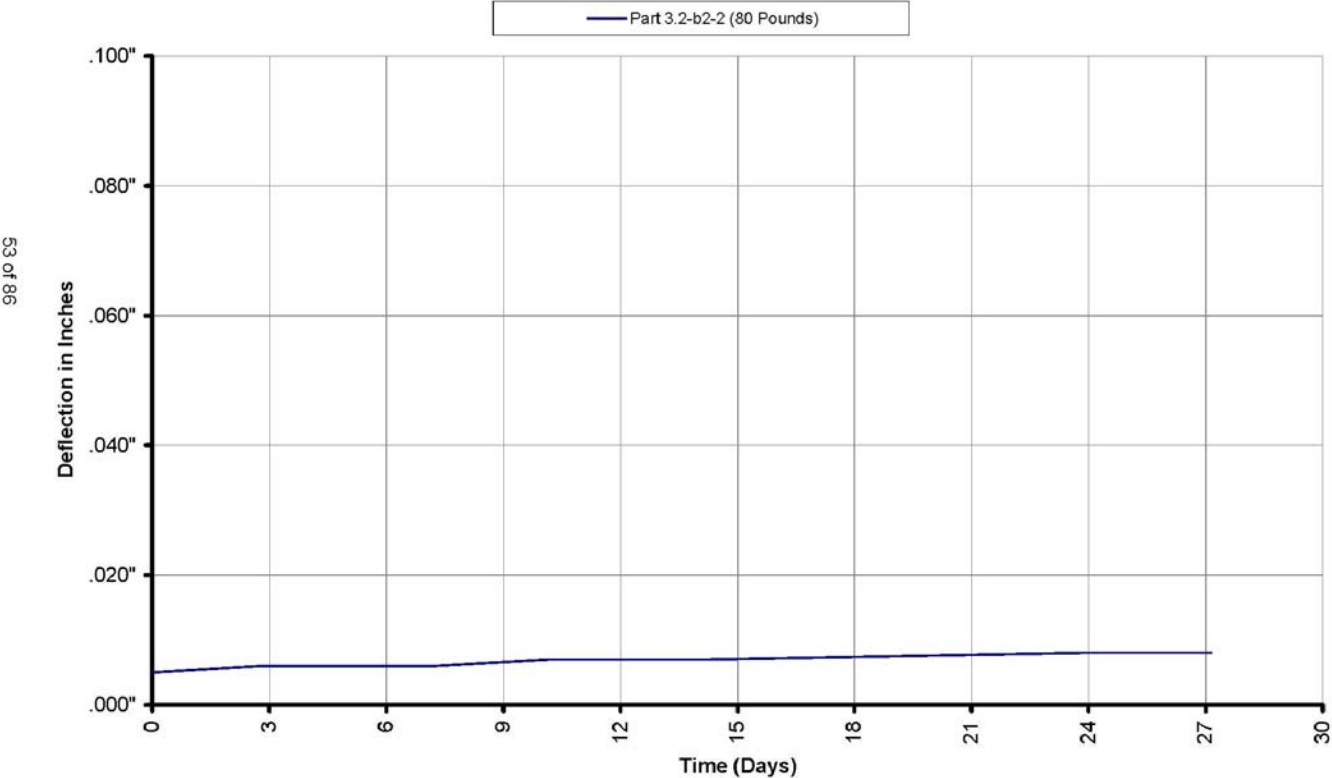

Progressive Engineering Inc.

ASTM D1761 Shear Testing

Date: 1/28/2010
Client: Newport Ventures, Inc.
Test: ASTM D1761 Shear Testing
Specimen Assembly No.: **3.2-(b2-3)**

Project No.: 2009-1407
Temp.: 68.0 °F
Humidity: 21% R.H.
Load Rate: .2" per minute

Specimen Construction

Furring: 3/4" Wood (reduced to 3/8")	Fastener: (2) #10 x 5" bugle-head screws, Item B10500SDRG
Foam: 4" EPS	Furring Pre-drill: 3/32" dia.
Sheathing: N/A	Remaining Material Pre-drill: 3/32" dia.
Stud: Steel (54 mil)	

Test Results

Sample	Maximum Load (lbf)	Deflection at Max. Load	Load (lbf) at:				*Connection Yield Mode
			.015" Defl.	.125" Defl.	.250" Defl.	.375" Defl.	
1	602	1.341"	150	191	239	280	II
2	580	1.501"	99	134	162	191	II
3	537	1.485"	126	148	179	216	II
Average	573	1.442"	125	158	193	229	
COV	6%	6%	20%	19%	21%	20%	

*Based on Single Shear Connection in Figure 1 of the AF&PA, NDS, Technical Report 12.

54 of 86



Specimen Construction



Typical Test Set-up

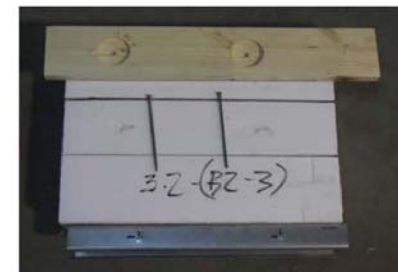

Typical Failure

Newport Ventures, Inc.
Shear Test on Assembly 3.2-(b2-3) (4" Foam)
Load vs Deflection

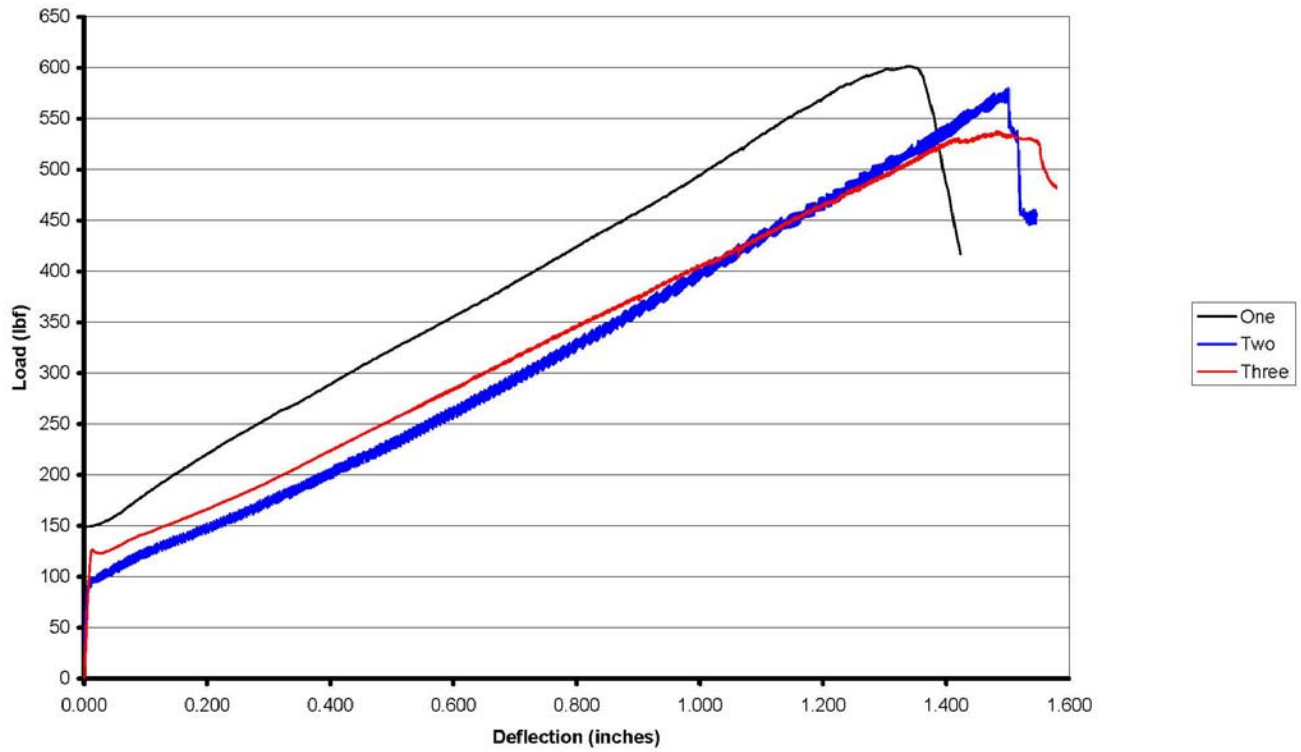

55 of 86

Progressive Engineering Inc.

ASTM D1761 Shear Testing

Date: 1/22/2010
Client: Newport Ventures, Inc.
Test: ASTM D1761 Shear Testing
Specimen Assembly No.: 3.2-(b2-4)

Project No.: 2009-1407
Temp.: 69.0 °F
Humidity: 23% R.H.
Load Rate: .2" per minute

Specimen Construction

Furring: 3/4" Wood	Fastener: (2) #10 x 3-1/2" bugle-head screws, Item B10350SDL2RG
Foam: 2" EPS	Furring Predrill: 3/32" dia.
Sheathing: N/A	Remaining Material Predrill: 3/32" dia.
Stud: Steel (54 mil)	

Test Results

Sample	Maximum Load (lbf)	Deflection at Max. Load	Load (lbf) at:				*Connection Yield Mode
			.015" Defl.	.125" Defl.	.250" Defl.	.375" Defl.	
1	812	1.635"	110	179	250	321	II
2	831	1.486"	126	215	294	362	II
3	825	1.677"	105	174	220	275	II
Average	823	1.599"	114	189	255	319	
COV	1%	6%	10%	12%	15%	14%	

*Based on Single Shear Connection in Figure 1 of the AF&PA, NDS, Technical Report 12.

56 of 86



Specimen Construction



Typical Test Set-up



Typical Failure

Progressive Engineering Inc.

Newport Ventures, Inc.
Shear Test on Assembly 3.2-(b2-4) (2" Foam)
Load vs Deflection

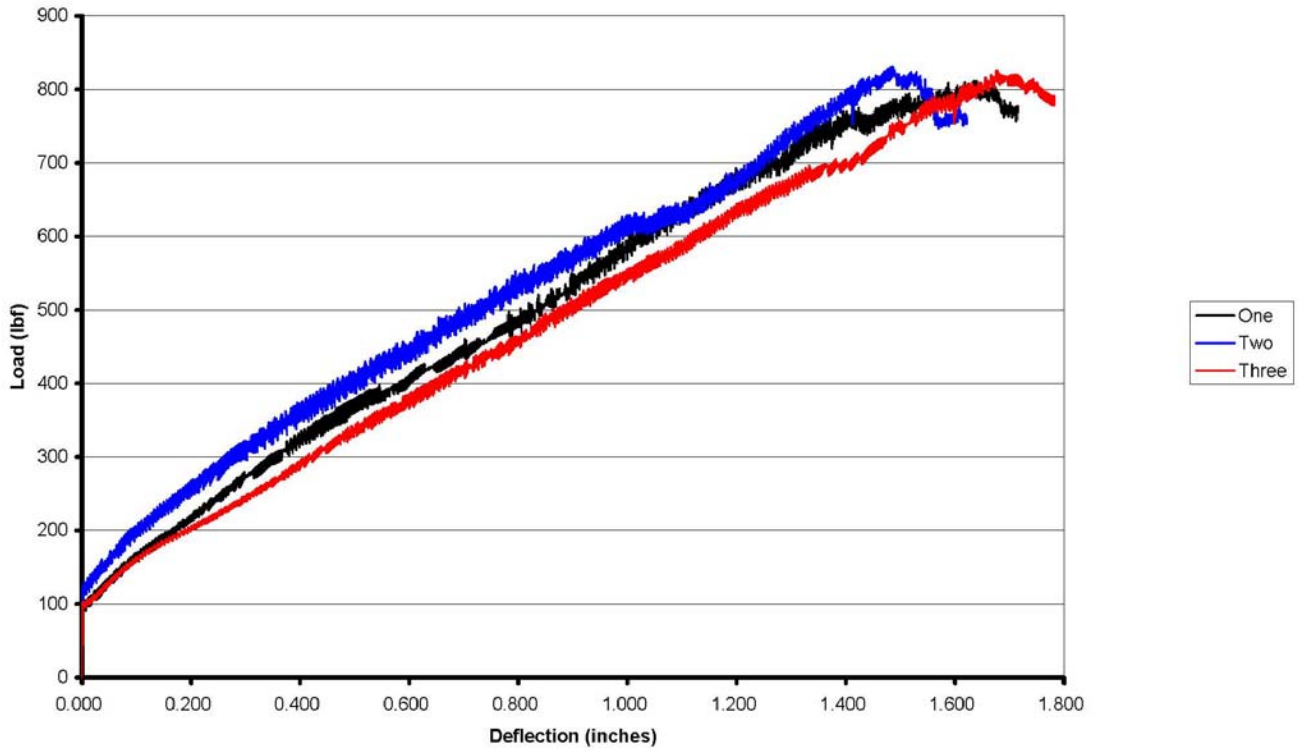

57 of 86

Progressive Engineering Inc.

ASTM D1761 Shear Testing

Date: 12/28/2009
Client: Newport Ventures, Inc.
Test: ASTM D1761 Shear Testing
Specimen Assembly No.: 3.2-(c1)

Project No.: 2009-1407
Temp.: 70.0 °F
Humidity: 21% R.H.
Load Rate: .2" per minute

Specimen Construction

Furring: 3/4" Wood	Fastener: (2) 0.135" x 3-1/2" 16d sinker nails
Foam: 1" EPS	Furring Predrill: N/A
Sheathing: N/A	Remaining Material Predrill: N/A
Stud: Wood 2x4	

Test Results

Sample	Maximum Load (lbf)	Deflection at Max. Load	Load (lbf) at:				*Connection Yield Mode
			.015" Defl.	.125" Defl.	.250" Defl.	.375" Defl.	
1	1016	1.753"	196	368	473	582	IV

*Based on Single Shear Connection in Figure 1 of the AF&PA, NDS, Technical Report 12.

58 of 86



Specimen Construction



Typical Test Set-up



Typical Failure

Newport Ventures, Inc.
Shear Test on Assembly 3.2-(c1) (1" Foam)
Load vs Deflection

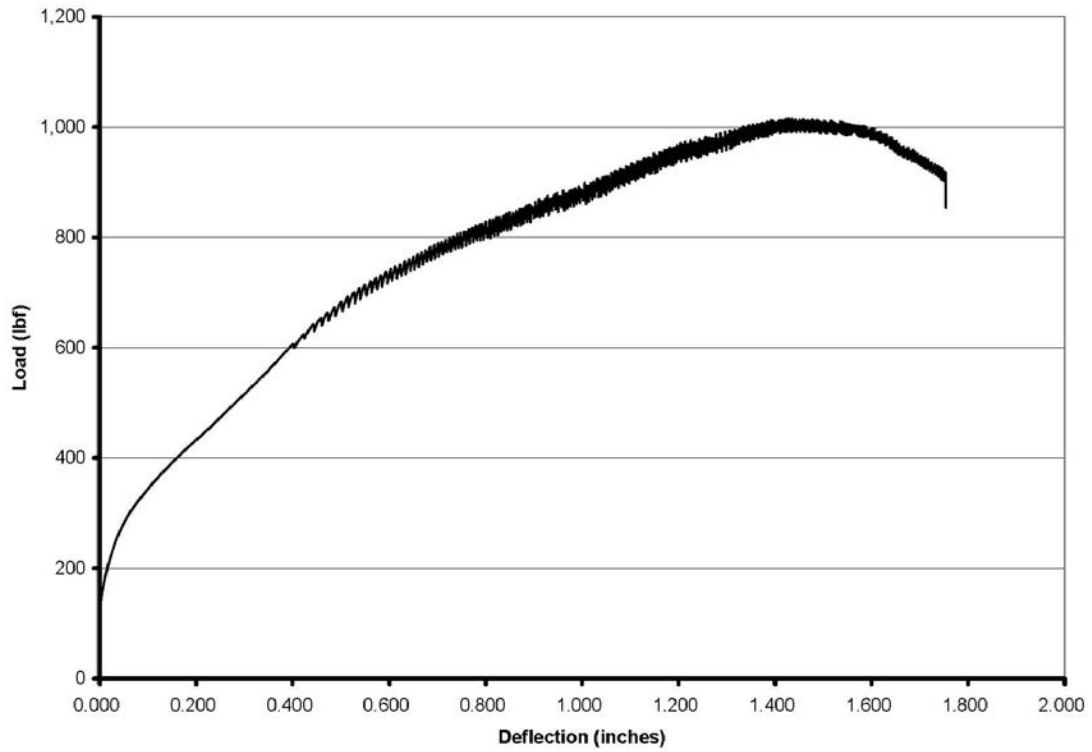

59 of 86

Progressive Engineering Inc.

ASTM D1761 Shear Testing

Date: 12/28/2009
Client: Newport Ventures, Inc.
Test: ASTM D1761 Shear Testing
Specimen Assembly No.: 3.2-(c2)

Project No.: 2009-1407
Temp.: 70.0 °F
Humidity: 21% R.H.
Load Rate: .2" per minute

Specimen Construction

Furring: 3/4" Wood	Fastener: (2) 1/4" x 7" lag screws
Foam: 4" EPS	Furring Predrill: 1/8" dia.
Sheathing: N/A	Remaining Material Predrill: 15/64" dia.
Stud: Wood 2x4	

Test Results

Sample	Maximum Load (lbf)	Deflection at Max. Load	Load (lbf) at:				*Connection Yield Mode
			.015" Defl.	.125" Defl.	.250" Defl.	.375" Defl.	
1	1099	2.207"	128	202	275	343	III _s

*Based on Single Shear Connection in Figure 1 of the AF&PA, NDS, Technical Report 12.

60 of 86



Specimen Construction



Typical Test Set-up



Typical Failure

Progressive Engineering Inc.

Newport Ventures, Inc.
Shear Test on Assembly 3.2-(c2) (4" Foam)
Load vs Deflection

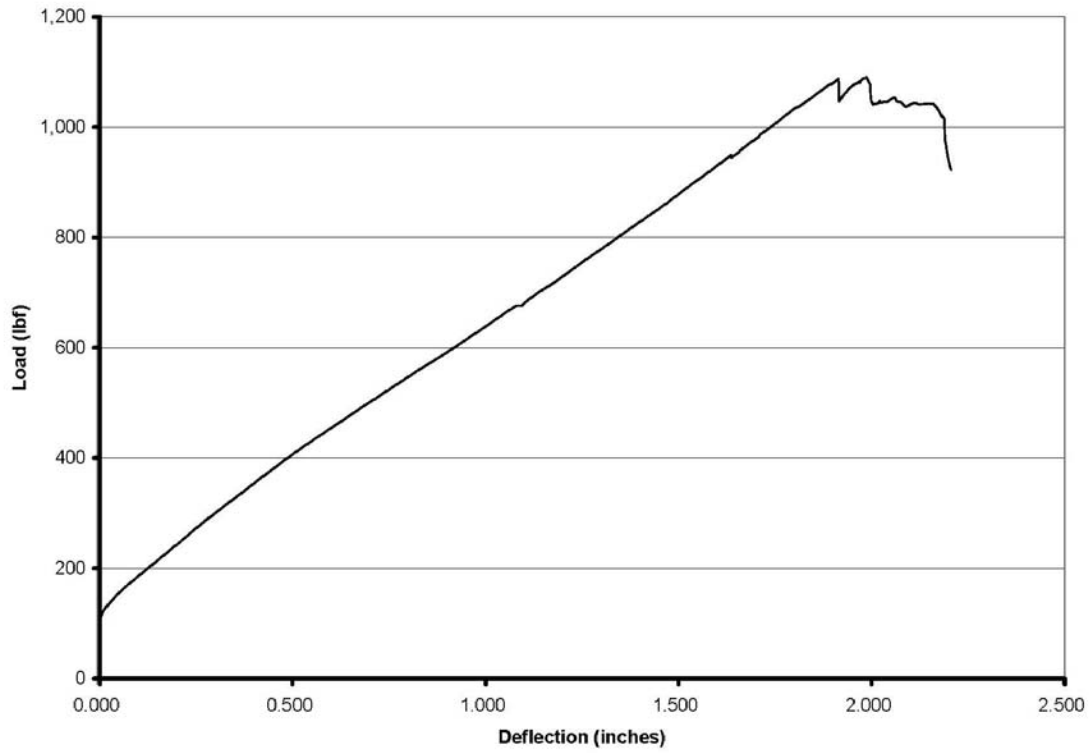

61 of 86

Progressive Engineering Inc.
ASTM D1761 Fastener Withdrawal Testing

Date: 1/28/2010
Client: Newport Ventures, Inc.
Test: ASTM D1761 Mechanical Fasteners in Wood

Project No.: 2009-1407
Temp.: 67.0 °F
Humidity: 24% R.H.
Load Rate: .1" per minute

Unit of measure = Pounds Force

Sample No.	Predrilled				Not Predrilled			
	7d Nail .100" shank dia.		16d Box Nail* .134" shank dia.		7d Box Nail .100" shank dia.		16d Box Nail .134" Shank dia.	
	7/16" OSB	3/4" OSB	7/16" OSB	3/4" OSB	7/16" OSB	3/4" OSB	7/16" OSB	3/4" OSB
1	33.5	59.4	98.4	109.9	20.7	77.8	55.9	134.9
2	37.5	53.7	89.4	183	32.3	54.1	48.4	66.3
3	35.6	63	99.5	211	43.3	91.8	66.8	93
4	39.5	72.4	81.4	146.5	33	46	51.6	112.9
5	43.4	63.9	60	172.8	30.8	39.2	67.1	92.3
6	36.9	72.1	79.9	225	59.4	65.1	45.5	100.3
Average (lbf):	37.7	64.1	84.8	174.7	36.6	62.3	55.9	100.0
COV:	9%	11%	17%	24%	36%	32%	17%	23%

Unit of measure = Pounds Force

Sample No.	#8 x 3" Wood Screw (Predrilled) .124" shank dia.		1/4" x 3" Lag Screw (Predrilled) .180" shank dia.		Bright Common Nails 16d Nail (Predrilled) .160" shank dia.	
	7/16" OSB	3/4" OSB	7/16" OSB	3/4" OSB	7/16" OSB	3/4" OSB
	1	245	403	296	352	46.3
2	170.5	445	392	528	66.2	107
3	298	346	420	541	56.8	106.6
4	211	359	289	587	86.4	96.3
5	158	292	234	674	64.2	123.7
6	204	477	297	445	65.6	114.9
Average (lbf):	214.4	387.0	321.3	521.2	64.3	105.9
COV:	24%	18%	22%	21%	21%	12%

Note: Shank Diameter was the average measured diameter.

* Surface roughness noted.

APPENDIX

Newport Ventures, Inc.
2009-1407

63 of 86

Progressive Engineering Inc.

ASTM D2395-07a Specific Gravity of Wood Test

Date: 1/8/10
 Client: **Newport Ventures, Inc.**
 Test Specimen: 1x4 SPF (Siding/Furring Strips)

PEI Project No.: 2009-1407

AVERAGE								
Specimen No.	Size @ Test Moisture Content			Specimen Mass (g)		Volume ² at Test (in ³)	Specific Gravity ³	Moisture Content ⁴ (%)
	Width	Length	Depth	At Test	Oven Dry ¹			
3.2 A1-1	2.027"	2.965"	0.745"	38.92 g	35.75 g	4.48	0.49	9%
3.2 A1-2	2.029"	2.979"	0.746"	39.85 g	36.53 g	4.51	0.49	9%
3.2 A1-3	2.029"	2.982"	0.746"	40.89 g	37.46 g	4.51	0.51	9%
3.2 C1-1	2.032"	2.963"	0.740"	38.09 g	35.05 g	4.46	0.48	9%
3.2 C1-2	2.030"	2.987"	0.744"	37.13 g	33.71 g	4.51	0.46	10%
3.2 C1-3	2.031"	2.973"	0.743"	37.36 g	33.92 g	4.49	0.46	10%
Average							0.48	9%

Notes: Samples cut from lumber used for siding and furring strips in Assembly Shear and Long-Term Creep Testing.

¹. The Oven Dry weight is based on drying at 103°C until two consecutive readings, 3 hour intervals, differ less than 0.01g.

². The Volume at Test is based on the average measurements taken at the original moisture content.

³. The Specific Gravity shown is based on the Oven-Dry mass and the Volume at Test using the constant (K=0.61) as defined in Section 13.2.1 of ASTM D2395.

⁴. The Moisture Content was calculated using the equation described in Section 13.1.1 of ASTM D2395.

Progressive Engineering Inc.

ASTM D2395-07a Specific Gravity of Wood Test

Date: 1/8/10

PEI Project No.: 2009-1407

Client: Newport Ventures, Inc.

Test Specimen: 2x4 SPF Framing

AVERAGE										
Specimen No.	Size @ Test			Moisture Content		Specimen Mass (g)		Volume ²	Specific Gravity ³	Moisture Content ⁴ (%)
	Width	Length	Depth	At Test	Oven Dry ¹	at Test (in ³)				
3.2 A2-1-1	2.027"	2.986"	1.459"	77.64 g	70.64 g	8.83			0.49	10%
3.2 A2-1-2	2.025"	2.992"	1.467"	76.38 g	68.89 g	8.89			0.47	11%
3.2 A2-1-3	2.020"	2.991"	1.465"	77.12 g	69.59 g	8.85			0.48	11%
3.2 C1-21	2.029"	2.912"	1.468"	64.11 g	58.64 g	8.67			0.41	9%
3.2 C1-22	2.024"	2.978"	1.488"	62.10 g	56.19 g	8.97			0.38	11%
3.2 C1-23	2.023"	2.996"	1.480"	65.19 g	58.90 g	8.97			0.40	11%
Average									0.44	10%

Notes: Samples cut from lumber used for framing in Assembly Shear and Long-Term Creep Testing.

¹. The Oven Dry weight is based on drying at 103°C until two consecutive readings, 3 hour intervals, differ less than 0.01g.

². The Volume at Test is based on the average measurements taken at the original moisture content.

³. The Specific Gravity shown is based on the Oven-Dry mass and the Volume at Test using the constant (K=.061) as defined in Section 13.2.1 of ASTM D2395.

⁴. The Moisture Content was calculated using the equation described in Section 13.1.1 of ASTM D2395.

Progressive Engineering Inc.

ASTM D2395-07a Specific Gravity of Wood Test

Date: 1/11/10

PEI Project No.: 2009-1407

Client: Newport Ventures, Inc.

Test Specimen: 7/16" OSB

Specimen No.	AVERAGE			Specimen Mass (g)		Volume ²	Specific Gravity ³	Moisture Content ⁴ (%)
	Size @ Test	Moisture Content		At Test	Oven Dry ¹	Oven-Dry (cm ³)		
	Width	Length	Depth					
A1	1.990"	3.020"	0.438"	28.94 g	27.61 g	41.89	0.66	5%
A2	1.991"	3.020"	0.433"	27.18 g	25.89 g	41.33	0.63	5%
A3	2.003"	3.020"	0.428"	29.95 g	28.52 g	41.31	0.69	5%
A11	1.992"	2.993"	0.450"	29.58 g	28.31 g	43.21	0.66	4%
A12	1.999"	2.989"	0.450"	30.20 g	28.93 g	43.22	0.67	4%
A13	1.999"	2.988"	0.446"	27.41 g	26.18 g	42.28	0.62	5%
Average							0.65	5%

Notes: Samples cut from OSB used for Assembly Shear and Long-Term Creep Testing. Samples dipped in paraffin wax prior to volume measurement.

¹. The Oven Dry weight is based on drying at 103°C until two consecutive readings, 3 hour intervals, differ less than 0.01g.

². The Volume at Oven-Dry is based on Volume by Water Displacement (Method B-III of D2395).

³. The Specific Gravity shown is based on the Oven-Dry mass and the Volume at Test using the constant (K=1) as defined in Section 13.2.1 of ASTM D2395.

⁴. The Moisture Content was calculated using the equation described in Section 13.1.1 of ASTM D2395.

Progressive Engineering Inc.

ASTM D2395-07a Specific Gravity of Wood Test

Date: 1/11/10

PEI Project No.: 2009-1407

Client: Newport Ventures, Inc.

Test Specimen: 23/32" OSB

AVERAGE										
Specimen No.	Size @ Test			Moisture Content		Specimen Mass (g)		Volume ²	Specific Gravity ³	Moisture Content ⁴ (%)
	Width	Length	Depth	At Test	Oven Dry ¹	Oven-Dry (cm ³)				
B1	2.005"	3.021"	0.719"	48.88 g	46.96 g	69.21			0.68	4%
B2	2.007"	3.022"	0.713"	45.94 g	44.18 g	68.51			0.64	4%
B3	2.001"	3.024"	0.716"	47.71 g	45.73 g	68.96			0.66	4%
B11	1.999"	2.999"	0.713"	43.05 g	41.33 g	67.54			0.61	4%
B12	2.003"	3.003"	0.711"	43.93 g	42.17 g	67.58			0.62	4%
B13	1.997"	2.991"	0.711"	44.96 g	43.26 g	67.12			0.64	4%
Average									0.64	4%

Notes: Samples cut from OSB used for Assembly Shear and Long-Term Creep Testing. Samples dipped in paraffin wax prior to volume measurement.

¹. The Oven Dry weight is based on drying at 103°C until two consecutive readings, 3 hour intervals, differ less than 0.01g.

². The Volume at Oven-Dry is based on Volume by Water Displacement (Method B-III of D2395).

³. The Specific Gravity shown is based on the Oven-Dry mass and the Volume at Test using the constant (K=1) as defined in Section 13.2.1 of ASTM D2395.

⁴. The Moisture Content was calculated using the equation described in Section 13.1.1 of ASTM D2395.

Progressive Engineering Inc.

ASTM C303 Foam Density Test

Date: 1/8/10

PEI Project No.: 2009-1407

Client: Newport Ventures, Inc.

Test Specimen: 1" EPS Foam (Type II)

Specimen No.	AVERAGE Size @ Test Moisture Content			Specimen Mass (g)		Volume ² (in ³)	Volume (ft ³)	Density ³ (lb/ft ³)
	Width	Length	Depth	At Test	Conditioned ¹			
A1	4.016"	7.987"	1.022"	11.67 g	11.53 g	32.78	0.019	1.34
A2	4.018"	7.997"	1.020"	11.69 g	11.54 g	32.77	0.019	1.34
A3	4.019"	7.984"	1.021"	11.83 g	11.62 g	32.76	0.019	1.35
Average								1.34

Notes: Samples cut from foam used in Assembly Shear and Long-Term Creep Testing.

¹- The Conditioned weight is based on equilibrium at 73°F and 50% R.H. per ASTM C578.

²- The Volume at Test is based on the average measurements taken at the original moisture content.

³- Density is based on Conditioned Mass. The density was converted to pounds per cubic foot as required by ASTM C578.

Progressive Engineering Inc.

ASTM C303 Foam Density Test

Date: 1/8/10

PEI Project No.: 2009-1407

Client: Newport Ventures, Inc.

Test Specimen: 2" EPS Foam (Type II)

Specimen No.	AVERAGE			Specimen Mass (g)		Volume ² (in ³)	Volume (ft ³)	Density ³ (lb/ft ³)
	Size @ Test	Moisture Content		At Test	Conditioned ¹			
C1	3.994"	8.015"	1.995"	22.31 g	22.01 g	63.86	0.037	1.31
C2	3.982"	8.011"	1.996"	22.60 g	22.07 g	63.67	0.037	1.32
C3	3.984"	8.002"	1.995"	22.67 g	22.07 g	63.60	0.037	1.32
Average								1.32

Notes: Samples cut from foam used in Assembly Shear and Long-Term Creep Testing.

¹- The Conditioned weight is based on equilibrium at 73°F and 50% R.H. per ASTM C578.

²- The Volume at Test is based on the average measurements taken at the original moisture content.

³- Density is based on Conditioned Mass. The density was converted to pounds per cubic foot as required by ASTM C578.

Progressive Engineering Inc.

ASTM C303 Foam Density Test

Date: 1/8/10

PEI Project No.: 2009-1407

Client: Newport Ventures, Inc.

Test Specimen: 4" EPS Foam (Type II)

Specimen No.	AVERAGE Size @ Test Moisture Content			Specimen Mass (g)		Volume ² (in ³)	Volume (ft ³)	Density ³ (lb/ft ³)
	Width	Length	Depth	At Test	Conditioned ¹			
A41	4.016"	7.995"	3.972"	42.61 g	42.39 g	127.53	0.074	1.26
A42	4.022"	7.992"	3.972"	42.68 g	42.45 g	127.68	0.074	1.26
A43	4.019"	7.984"	3.968"	43.07 g	42.77 g	127.32	0.074	1.28
Average								1.27

Notes: Samples cut from foam used in Assembly Shear and Long-Term Creep Testing.

¹- The Conditioned weight is based on equilibrium at 73°F and 50% R.H. per ASTM C578.

²- The Volume at Test is based on the average measurements taken at the original moisture content.

³- Density is based on Conditioned Mass. The density was converted to pounds per cubic foot as required by ASTM C578.

Progressive Engineering Inc.
ASTM E8 Tensile Test

Date: 1/29/2010
Client: Newport Ventures, Inc.

Project No.: 2009-1407

Specimen: Steel Coupons. See Below
Test: ASTM E8 Tensile Test

Sample ID	Sample No.	Width (in)	Thickness (in)	Area (in ²)	Tensile Yield Strength		Tensile Ultimate	
					OS @ .2 (lbf)	OS @ .2 (psi)	Ultimate (lbf)	Ultimate (psi)
33 mil stud	1	.483	.032	.01546	328	21,222	727	47,037
33 mil stud	2	.499	.031	.01547	319	20,622	754	48,743
33 mil stud	3	.500	.031	.01550	344	22,194	754	48,645
54 mil stud	1	.507	.053	.02687	1492	55,525	1824	67,880
54 mil stud	2	.502	.054	.02711	1463	53,969	1801	66,438
54 mil stud	3	.503	.054	.02716	1500	55,224	1833	67,484
33 mil hat channel	1	.500	.034	.01700	1195	70,294	1381	81,235
33 mil hat channel	2	.497	.034	.01690	1173	69,416	1384	81,903
33 mil hat channel	3	.494	.034	.01680	1164	69,302	1379	82,103

Progressive Engineering Inc.
ASTM F1575 Fastener Bending Yield Moment

Date: 2/2/2010
 Client: Newport Ventures, Inc.

Project No.: 2009-1407

Fastener: 16D Hot Dipped Box Nails*

Measured Fastener Dimensions

Ten Specimen Average (inch)		
Shank Dia.	Head Dia.	Length
.142 / .134	.347 / .345	3.542 / 3.535

* Measurements taken before and after the galvanized layer was removed.

Fastener Bending Yield Moment

Sample No.	Yield Load P (lbf) ¹	Yield Strength F _y (psi) ²
1	111	103,799
2	114	106,604
3	117	109,409
4	118	110,344
5	115	107,539
Average	115	107,539
COV	2.4%	2.4%

Test Span (in)= 1.5
 Load Rate = .25"/min

¹ - Fastener Yield Load is derived from the load/deflection curve at a point offset 5% of the fastener diameter, as described in Section 10 of ASTM F1575.

² - Fastener Yield Strength is calculated with the equation found in Annex A1 of ASTM F1575 using the average shank diameter.

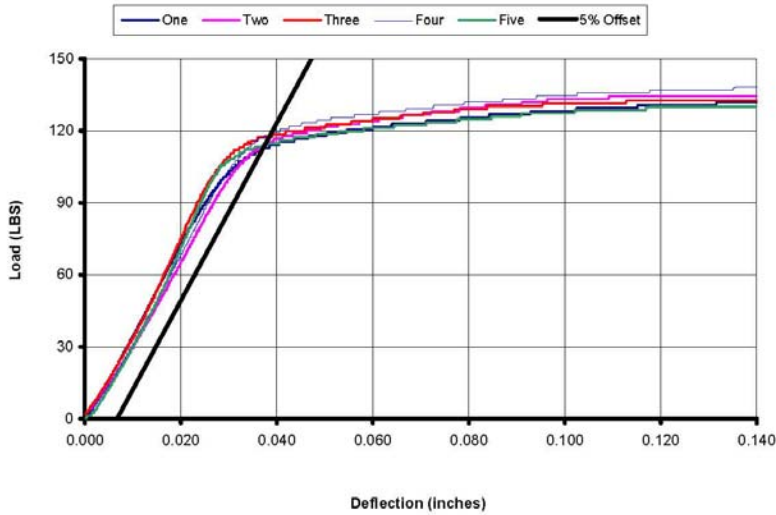

Progressive Engineering Inc.
ASTM F1575 Fastener Bending Yield Moment

Date: 2/2/2010
 Client: Newport Ventures, Inc.

Project No.: 2009-1407

Fastener: 7d Box Nails

Measured Fastener Dimensions

Ten Specimen Average (inch)		
Shank Dia.	Head Dia.	Length
0.100	0.244	2.323

Fastener Bending Yield Moment

Sample No.	Yield Load P (lbf) ¹	Yield Strength F _y (psi) ²
1	83	136,950
2	80	132,000
3	78	128,700
4	79	130,350
5	75	123,750
Average	79	130,350
COV	3.7%	3.7%

Test Span (in)= 1.1
 Load Rate = .25"/min

¹- Fastener Yield Load is derived from the load/deflection curve at a point offset 5% of the fastener diameter, as described in Section 10 of ASTM F1575.

²- Fastener Yield Strength is calculated with the equation found in Annex A1 of ASTM F1575 using the average shank diameter.

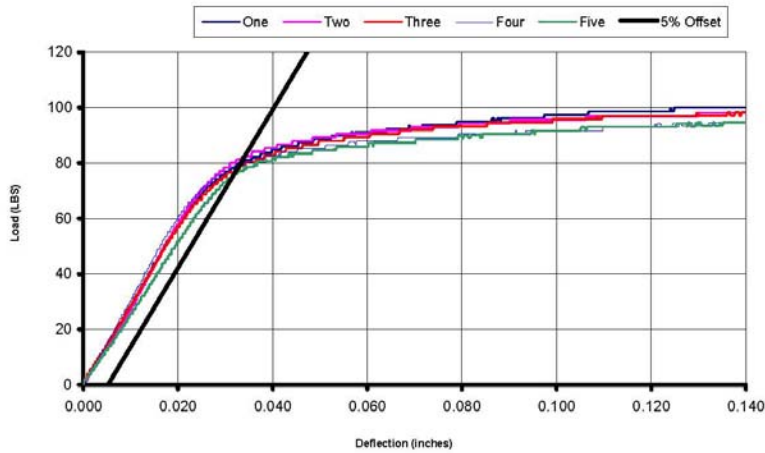

Progressive Engineering Inc.

ASTM F1575 Fastener Bending Yield Moment

Date: 2/2/2010

Project No.: 2009-1407

Client: Newport Ventures, Inc.

Fastener: 10 Ga x 4" Long Maze Foundry Nail

Measured Fastener Dimensions

Ten Specimen Average (inch)		
Shank Dia.	Head Dia.	Length
0.135	0.362	4.067

* Measurements taken before and after the galvanized layer was removed.

Fastener Bending Yield Moment

NOTE: Insufficient fasteners available for Bending Yield Testing. See 10 Ga x 6" Long Maze Foundry Nails for Comparable Results.

Progressive Engineering Inc.
ASTM F1575 Fastener Bending Yield Moment

Date: 2/2/2010
 Client: Newport Ventures, Inc.

Project No.: 2009-1407

Fastener: 10 Ga x 6" Long Maze Foundry Nail

Measured Fastener Dimensions

Ten Specimen Average (inch)		
Shank Dia.	Head Dia.	Length
0.135	0.337	6.047

* Measurements taken before and after the galvanized layer was removed.

Fastener Bending Yield Moment

Sample No.	Yield Load P (lbf) ¹	Yield Strength F _y (psi) ²
1	127	116,141
2	131	119,799
3	135	123,457
4	127	116,141
5	138	126,200
Average	132	120,348
COV	3.7%	3.7%

Test Span (in)= 1.5
 Load Rate = .25"/min

¹ - Fastener Yield Load is derived from the load/deflection curve at a point offset 5% of the fastener diameter, as described in Section 10 of ASTM F1575.

² - Fastener Yield Strength is calculated with the equation found in Annex A1 of ASTM F1575 using the average shank diameter.

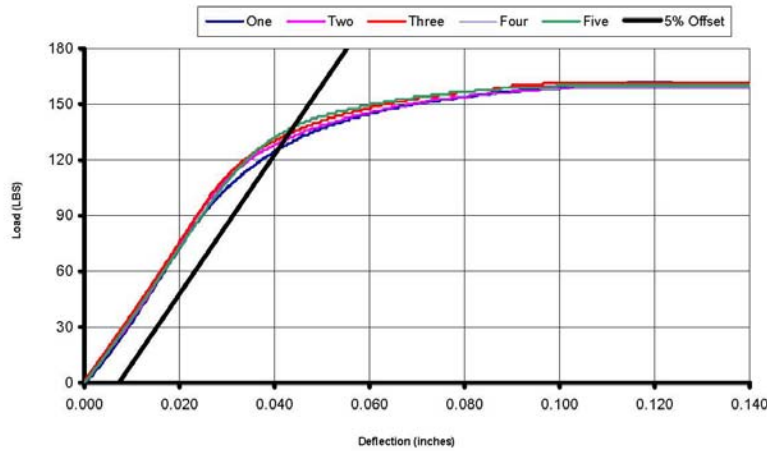

Progressive Engineering Inc.

ASTM F1575 Fastener Bending Yield Moment

Date: 2/2/2010

Project No.: 2009-1407

Client: Newport Ventures, Inc.

Fastener: #8 x 1-1/2" Standard Wood Screws

Measured Fastener Dimensions

Ten Specimen Average (inch)				
Root Dia.	Thread Dia.	Length	Shoulder Dia.	Head Dia.
0.111	0.157	1.480	0.121	0.303

Fastener Bending Yield Moment

NOTE: The wood screw was too short to be tested at the 1.1" required span.

Progressive Engineering Inc.

ASTM F1575 Fastener Bending Yield Moment

Date: 2/2/2010

Project No.: 2009-1407

Client: Newport Ventures, Inc.

Fastener: #8 x 2" Standard Wood Screws

Measured Fastener Dimensions

Ten Specimen Average (inch)				
Root Dia.	Thread Dia.	Length	Shoulder Dia.	Head Dia.
0.106	0.165	1.972	0.121	0.301

Fastener Bending Yield Moment

Sample No.	Yield Load P (lbf) ¹	Yield Strength F _y (psi) ²
1	152	210,577
2	147	203,650
3	140	193,952
4	149	206,420
5	149	206,420
Average	147	204,204
COV	3.1%	3.1%

Test Span (in)= 1.1
Load Rate = .25"/min

¹- Fastener Yield Load is derived from the load/deflection curve at a point offset 5% of the fastener diameter, as described in Section 10 of ASTM F1575.

²- Fastener Yield Strength is calculated with the equation found in Annex A1 of ASTM F1575 using the average root diameter or the average shoulder diameter, based on the location of the loading nose.

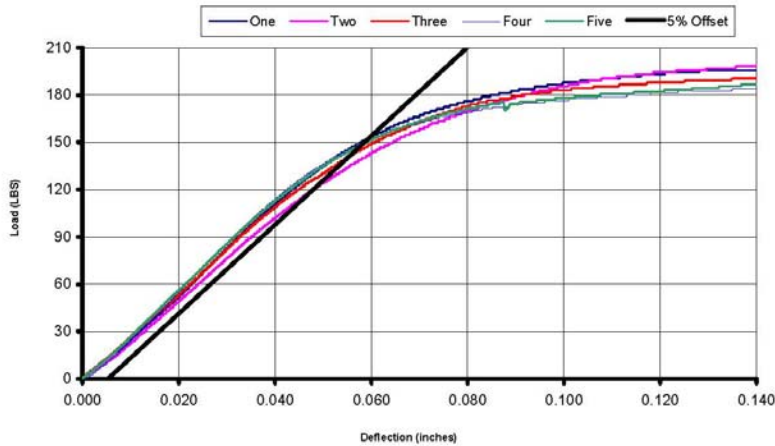

Progressive Engineering Inc.

ASTM F1575 Fastener Bending Yield Moment

Date: 2/22/2010

Project No.: 2009-1407

Client: Newport Ventures, Inc.

Fastener: #8 x 3" Standard Wood Screws

Measured Fastener Dimensions

Ten Specimen Average (inch)				
Root Dia.	Thread Dia.	Length	Shoulder Dia.	Head Dia.
0.115	0.160	2.977	0.126	0.305

Fastener Bending Yield Moment

Sample No.	Yield Load P (lbf) ¹	Yield Strength F _y (psi) ²
1	100	108,490
2	111	120,424
3	114	123,679
4	106	115,000
5	99	107,405
Average	106	115,000
COV	6.2%	6.2%

Test Span (in)= 1.1
Load Rate = .25"/min

¹- Fastener Yield Load is derived from the load/deflection curve at a point offset 5% of the fastener diameter, as described in Section 10 of ASTM F1575.

²- Fastener Yield Strength is calculated with the equation found in Annex A1 of ASTM F1575 using the average root diameter or the average shoulder diameter, based on the location of the loading nose.

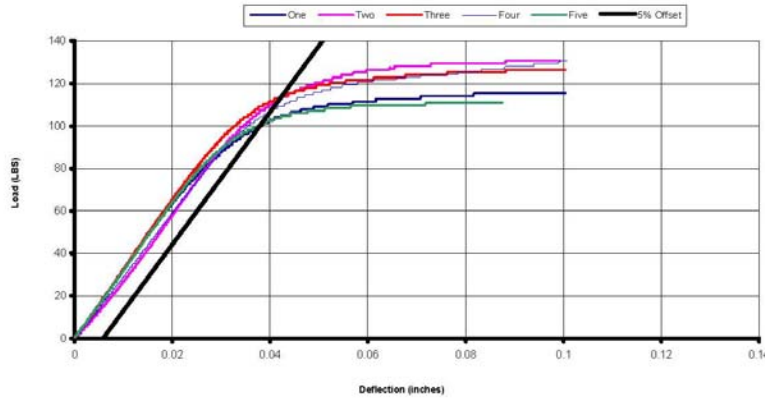

Progressive Engineering Inc.

ASTM F1575 Fastener Bending Yield Moment

Date: 2/2/2010

Project No.: 2009-1407

Client: Newport Ventures, Inc.

Fastener: 1/4" x 2" Hex Head Lag

Measured Fastener Dimensions

Ten Specimen Average (inch)				
Root Dia.	Thread Dia.	Length	Shoulder Dia.	Head Size*
0.182	0.242	1.974	0.238	0.429

*-Perpendicular dimension from opposing flat surfaces on hexagon head.

Fastener Bending Yield Moment

NOTE: The lag screw was too short to be tested at the 2.2" required span.

Progressive Engineering Inc.

ASTM F1575 Fastener Bending Yield Moment

Date: 2/2/2010

Project No.: 2009-1407

Client: Newport Ventures, Inc.

Fastener: 1/4" x 3" Hex Head Lag

Measured Fastener Dimensions

Ten Specimen Average (inch)				
Root Dia.	Thread Dia.	Length	Shoulder Dia.	Head Size*
0.180	0.247	2.975	0.241	0.431

*-Perpendicular dimension from opposing flat surfaces on hexagon head.

Fastener Bending Yield Moment

Sample No.	Yield Load P (lbf) ¹	Yield Strength F _y (psi) ²
1	163	92,233
2	162	91,667
3	153	86,574
4	150	84,877
5	156	88,272
Average	157	88,724
COV	3.6%	3.6%

Test Span (in)= 2.2
Load Rate = .25"/min

¹- Fastener Yield Load is derived from the load/deflection curve at a point offset 5% of the fastener diameter, as described in Section 10 of ASTM F1575.

²- Fastener Yield Strength is calculated with the equation found in Annex A1 of ASTM F1575 using the average root diameter or the average shoulder diameter, based on the location of the loading nose.

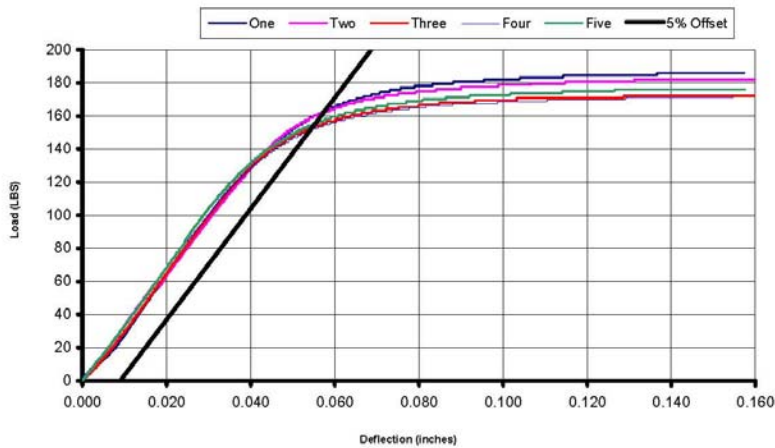

Progressive Engineering Inc.

ASTM F1575 Fastener Bending Yield Moment

Date: 2/2/2010

Project No.: 2009-1407

Client: Newport Ventures, Inc.

Fastener: 1/4" x 4" Hex Head Lag

Measured Fastener Dimensions

Ten Specimen Average (inch)				
Root Dia.	Thread Dia.	Length	Shoulder Dia.	Head Size*
0.178	0.245	3.944	0.234	0.431

*-Perpendicular dimension from opposing flat surfaces on hexagon head.

Fastener Bending Yield Moment

Sample No.	Yield Load P (lbf) ¹	Yield Strength F _y (psi) ²
1	193	112,930
2	188	110,005
3	183	107,079
4	182	106,494
5	195	114,101
Average	188	110,122
COV	3.1%	3.1%

Test Span (in)= 2.2
Load Rate = .25"/min

¹- Fastener Yield Load is derived from the load/deflection curve at a point offset 5% of the fastener diameter, as described in Section 10 of ASTM F1575.

²- Fastener Yield Strength is calculated with the equation found in Annex A1 of ASTM F1575 using the average root diameter or the average shoulder diameter, based on the location of the loading nose.

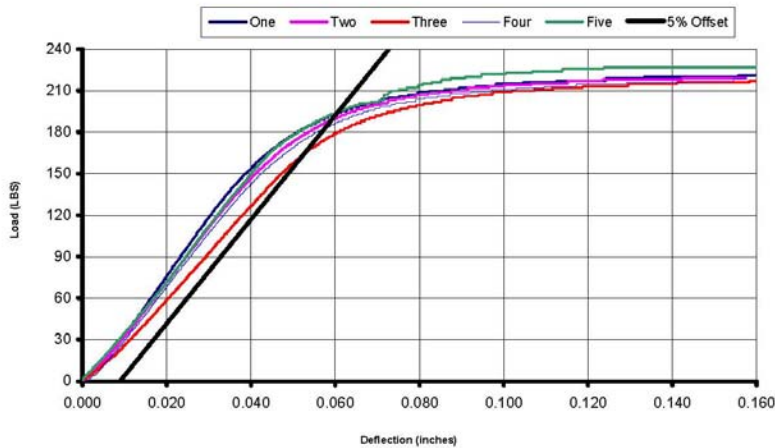

Progressive Engineering Inc.

ASTM F1575 Fastener Bending Yield Moment

Date: 2/2/2010

Project No.: 2009-1407

Client: Newport Ventures, Inc.

Fastener: 1/4" x 6" Hex Head Lag

Measured Fastener Dimensions

Ten Specimen Average (inch)				
Root Dia.	Thread Dia.	Length	Shoulder Dia.	Head Size*
0.181	0.249	6.099	0.239	0.431

*-Perpendicular dimension from opposing flat surfaces on hexagon head.

Fastener Bending Yield Moment

Sample No.	Yield Load P (lbf) ¹	Yield Strength F _y (psi) ²
1	151	84,034
2	137	76,243
3	136	75,686
4		
5		
Average	141	78,654
COV	5.9%	5.9%

Test Span (in)= 2.2
Load Rate = .25"/min

NOTE: Insufficient fasteners available for a complete set of Fastener Bending Tests.

¹ - Fastener Yield Load is derived from the load/deflection curve at a point offset 5% of the fastener diameter, as described in Section 10 of ASTM F1575.

² - Fastener Yield Strength is calculated with the equation found in Annex A1 of ASTM F1575 using the average root diameter or the average shoulder diameter, based on the location of the loading nose.

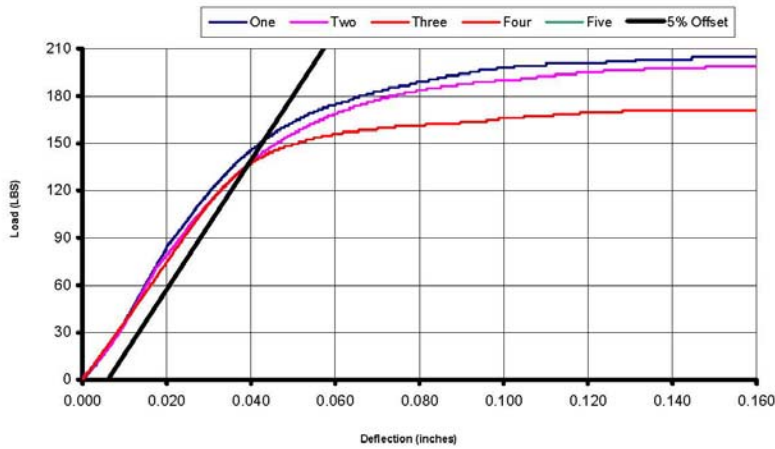

Progressive Engineering Inc.

ASTM F1575 Fastener Bending Yield Moment

Date: 2/2/2010

Project No.: 2009-1407

Client: Newport Ventures, Inc.

Fastener: 1/4" x 7" Hex Head Lag

Measured Fastener Dimensions

Ten Specimen Average (inch)				
Root Dia.	Thread Dia.	Length	Shoulder Dia.	Head Size*
0.179	0.247	7.049	0.239	0.432

*-Perpendicular dimension from opposing flat surfaces on hexagon head.

Fastener Bending Yield Moment

Sample No.	Yield Load P (lbf) ¹	Yield Strength F _y (psi) ²
1	170	97,815
2	166	95,513
3	166	95,513
4	169	97,239
5	167	96,088
Average	168	96,434
COV	1.1%	1.1%

Test Span (in)= 2.2
Load Rate = .25"/min

¹- Fastener Yield Load is derived from the load/deflection curve at a point offset 5% of the fastener diameter, as described in Section 10 of ASTM F1575.

²- Fastener Yield Strength is calculated with the equation found in Annex A1 of ASTM F1575 using the average root diameter or the average shoulder diameter, based on the location of the loading nose.

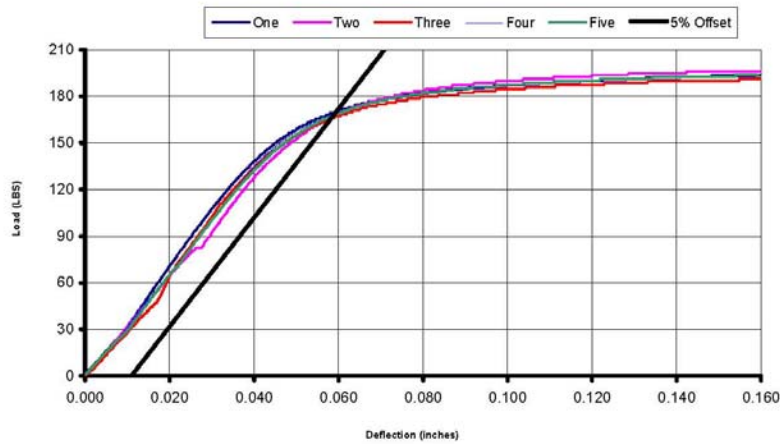

Progressive Engineering Inc.

ASTM F1575 Fastener Bending Yield Moment

Date: 2/2/2010

Project No.: 2009-1407

Client: Newport Ventures, Inc.

Fastener: #8 x 2-3/8" Long self-drilling, Grabber Screw

Measured Fastener Dimensions

Ten Specimen Average (inch)				
Root Dia.	Thread Dia.	Length	Shoulder Dia.	Head Dia.
0.108	0.159	2.345	0.131	0.325

Fastener Bending Yield Moment

Sample No.	Yield Load P (lbf) ¹	Yield Strength F _y (psi) ²
1	200	261,965
2	193	252,796
3	206	269,824
4	209	273,753
5	193	252,796
Average	200	262,227
COV	3.7%	3.7%

Test Span (in)= 1.1
Load Rate = .25"/min

¹ - Fastener Yield Load is derived from the load/deflection curve at a point offset 5% of the fastener diameter, as described in Section 10 of ASTM F1575.

² - Fastener Yield Strength is calculated with the equation found in Annex A1 of ASTM F1575 using the average root diameter or the average shoulder diameter, based on the location of the loading nose.

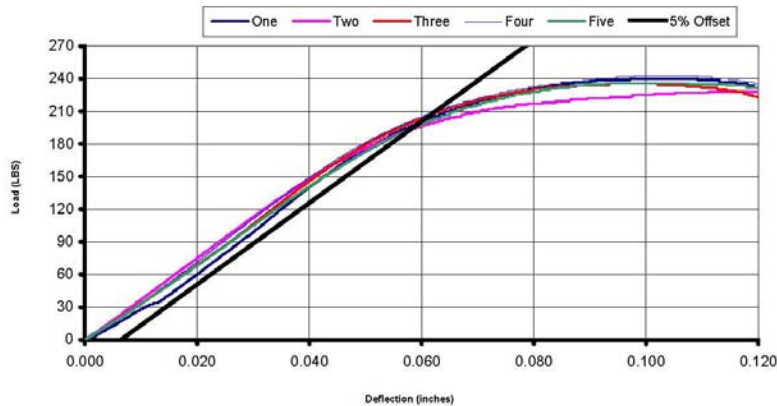

Progressive Engineering Inc.

ASTM F1575 Fastener Bending Yield Moment

Date: 2/2/2010

Project No.: 2009-1407

Client: Newport Ventures, Inc.

Fastener: #10 x 3.5" Long self-drilling, Grabber Screw

Measured Fastener Dimensions

Ten Specimen Average (inch)				
Root Dia.	Thread Dia.	Length	Shoulder Dia.	Head Dia.
0.131	0.184	3.486	0.151	0.341

Fastener Bending Yield Moment

Sample No.	Yield Load P (lbf) ¹	Yield Strength F _y (psi) ²
1	225	225,191
2	225	225,191
3	224	224,190
4	235	235,200
5	231	231,196
Average	228	228,194
COV	2.1%	2.1%

Test Span (in)= 1.5
Load Rate = .25"/min

¹- Fastener Yield Load is derived from the load/deflection curve at a point offset 5% of the fastener diameter, as described in Section 10 of ASTM F1575.

²- Fastener Yield Strength is calculated with the equation found in Annex A1 of ASTM F1575 using the average root diameter or the average shoulder diameter, based on the location of the loading nose.

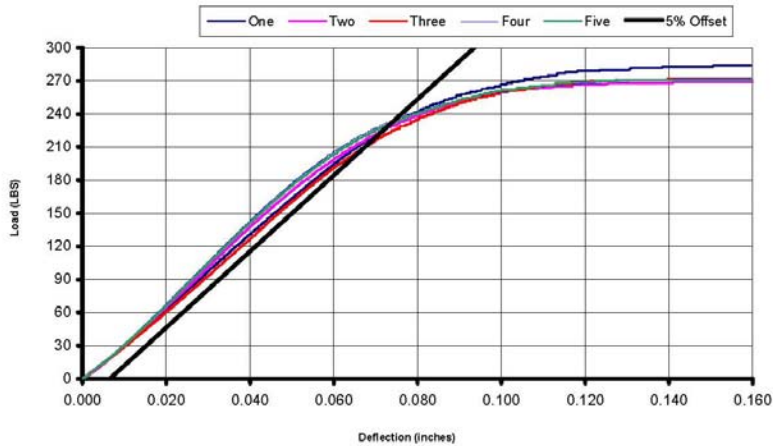

Progressive Engineering Inc.

ASTM F1575 Fastener Bending Yield Moment

Date: 2/2/2010

Project No.: 2009-1407

Client: Newport Ventures, Inc.

Fastener: #10 x 5" Long self-drilling, Grabber Screw

Measured Fastener Dimensions

Ten Specimen Average (inch)				
Root Dia.	Thread Dia.	Length	Shoulder Dia.	Head Dia.
0.130	0.185	4.986	0.151	0.342

Fastener Bending Yield Moment

Sample No.	Yield Load P (lbf) ¹	Yield Strength F _y (psi) ²
1	203	263,336
2	187	242,581
3	208	269,822
4	-	-
5	-	-
Average	199	258,580
COV	5.5%	5.5%

Test Span (in)= 1.9
Load Rate = .25"/min

NOTE: Insufficient fasteners available for a complete set of Fastener Bending Tests.

¹ - Fastener Yield Load is derived from the load/deflection curve at a point offset 5% of the fastener diameter, as described in Section 10 of ASTM F1575.

² - Fastener Yield Strength is calculated with the equation found in Annex A1 of ASTM F1575 using the average root diameter or the average shoulder diameter, based on the location of the loading nose.

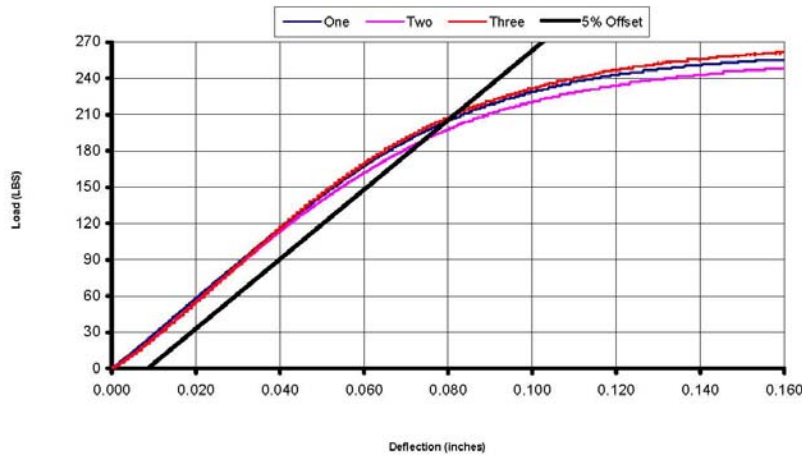

APPENDIX C
ANALYSIS OF CLADDING CONNECTIONS

Appendix C – Analysis of Cladding Connections

Cladding Connections to Cold-formed Steel Studs:																		
<i>33 mil steel hat channel to steel stud shear tests (steel-to-steel connections with and without gap):</i>																		
Test ID	Description	gap (foam) inches	Max Load per Screw (lbs)	Defl. @ Max. Load (in.)	Average Load (lbs) per Screw at Deflections:				Failure Mode	Material Properties & Dimensions (averaged)						nominal Fyb (screw) psi	Design Load at 0.015" Defl.	Safety Margin 0.015" / Max Load
					0.015"	0.125"	0.250"	0.375"		t1 (hat) inches	t2 (stud) inches	Fu (hat) psi	Fu (stud) psi	d-min inches	d-max inches			
3.1-(b1)	33mil hat, 1"EPS, 33mil stud, (2) #8x2-3/8" screws w/1/4" washer	1	242.5	0.653	21	40.5	73.5	125.5	II (rotation)	0.034	0.0313	81747	48142	0.108	0.159	273991	21	11.5
3.1-(b2)	33mil hat, 4"EPS, 54mil stud, (2) #10x5" screws w/1/4" washer	4	557.5	2.079	68	84.5	102	120.5	II (rotation)	0.034	0.0537	81747	67267	0.13	0.185	258580	68	8.2
3.1-(b3)	33mil hat, no EPS, 33mil stud, (2) #8x2-3/8" screws w/1/4" washer	0	624	0.146	260	594.5	624	624	Im (bearing)	0.034	0.0313	81747	48142	0.108	0.159	262227	n/a -- use AISI E4.3.1	
3.1-(b4)	33mil hat, 2"EPS, 33mil stud, (2) #10x3.5" screws w/1/4" washer	2	194.5	0.875	30.5	43.5	60.5	83.5	II (rotation)	0.034	0.0313	81747	48142	0.131	0.184	228194	30.5	6.4
3.1-(b5)	33mil hat, 2"EPS, 54mil stud, (2) #10x3.5" screws w/1/4" washer	2	964	1.619	69	96	124.5	157	Im (bearing)	0.034	0.0537	81747	67267	0.131	0.184	228194	69	14.0
NOTE: 3 reps were performed for each assembly All screws were bugle head, self-drilling tapping screws; 1/4" washer was standard cut washer; d-min is root diameter at threads, d-max is diameter of unthreaded portion.																		
<i>wood furring to steel stud shear tests (wood-to-steel connections with and without gap):</i>																		
Test ID	Description	gap (foam) inches	Max Load per Screw (lbs)	Defl. @ Max. Load (in.)	Average Load (lbs) per Screw at Deflections:				Failure Mode	Material Properties & Dimensions (averaged)						nominal Fyb (screw) psi	Design Load at 0.015" Defl.	Safety Margin 0.015" / Max Load
					0.015"	0.125"	0.250"	0.375"		t1 (furring) inches	t2 (stud) inches	G (furring) sp.grav.	Fu (stud) psi	d-min inches	d-max inches			
3.2-(b1-1)	3/4" wood furring, 1"EPS, 33mil stud, (2) #8 screws	1	175	0.387	45	98.5	137	168.5	IIIIm	0.75	0.0313	0.48	48142	0.108	0.159	273991	45	3.9
3.2-(b1-3)	3/8" wood furring, 1"EPS, 33mil stud, (2) #8 screws	1	220.5	0.661	41	73.5	103.5	140.5	II (rotation)	0.375	0.0313	0.48	48142	0.108	0.159	273991	41	5.4
3.2-(b1-4)	3/4" wood furring, no EPS, 33mil stud, (2) #8 screws	0	437	0.501	162.5	315	164.5	412	Im (bearing)	0.75	0.0313	0.48	48142	0.108	0.159	273991	162.5	2.7
3.2-(b1-5)	3/4" wood furring, 2"EPS, 33mil stud, (2) #10 screws	2	205	0.867	33.5	54.5	78.5	98.5	IIIIm	0.75	0.0313	0.48	48142	0.131	0.184	228194	33.5	6.1
3.2-(b2-4)	3/4" wood furring, 2"EPS, 54mil stud, (2) #10 screws	2	411.5	1.599	57	94.5	127.5	159.5	II (rotation)	0.75	0.0537	0.48	67267	0.131	0.184	228194	57	7.2
3.2-(b2-3)	3/8" wood furring, 4"EPS, 54mil stud, (2) #10 screws	4	286.5	1.442	62.5	79	96.5	114.5	II (rotation)	0.375	0.0537	0.48	67267	0.13	0.185	144606	62.5	4.6
NOTE: 3 reps were performed for each assembly																		
																AVG =	7.0	

Cladding Connections to Wood Materials (OSB Sheathing and Wood Studs):

33 mil steel hat channel to OSB wood structural panel sheathing (steel-to-wood connections with and without gap):

Test ID	Description	Max Load per Nail (lbs)	Defl. @ Max. Load (in.)	Average Load (lbs) per Nail at Deflections:				Failure Mode	Material Properties & Dimensions (averaged)						NDS/TR12 RATIO		Safety Margin	
				0.015"	0.125"	0.250"	0.375"		t1 (hat) inches	t2 (OSB) inches	Fu (hat) psi	G (OSB) sp grav.	d (nail) inches	Fyb (nail) psi	gap (foam) inches	5% offset (lbs)		5% offset to 0.015"
3.1-(a1)	33mil hat, 1"EPS, 7/16" OSB, (4) 0.099"x2.25" nails	83	1.295	15.5	37.75	50.25	58.75	IV	0.034	0.441	81747	0.65	0.1	130350	1	23	1.48	3.61
3.1-(a2)	33mil hat, 4"EPS, 23/32" OSB, (4) 0.135" (10g) x 6" nails	192.75	3.372	19.75	37.5	53.5	67	III	0.034	0.714	81747	0.64	0.135	120348	4	13	0.66	14.83
3.1-(a3)	33mil hat, no EPS, 7/16" OSB, (4) 0.099"x2.25" nails	200.5	0.101	81	200.25	200.5	200.5	III	0.034	0.441	81747	0.65	0.1	130350	0	133	1.64	1.51

NOTE: 3 reps were performed for each assembly

wood furring to OSB wood structural panel sheathing (wood-to-wood connections with and without gap):

Test ID	Description	gap (foam) inches	Max Load per Fastener (lbs)	Defl. @ Max. Load (in.)	Average Load (lbs) per Fastener at Deflections:				Failure Mode	Material Properties & Dimensions (averaged)						Fyb (fastener) psi	5% offset (lbs)	5% offset to 0.015"	Safety Margin
					0.015"	0.125"	0.250"	0.375"		t1 (furring) inches	t2 (OSB) inches	G (furring) sp. Grav.	G (OSB) sp. grav.	d-min inches	d-max inches				
3.2-(a1-1)	3/4" wood furring, 1" EPS, 7/16" OSB, (2) #8 x 3" wood screws	1	192	0.463	68	122	159	182	III	0.75	0.441	0.48	0.65	0.115	0.16	115000	84	1.24	2.29
3.2-(a1-3)	3/8" wood furring, 1"EPS, 7/16" OSB, (2) 0.088"x2-1/4" nails	1	72	0.898	24.5	43	53.5	62	III	0.375	0.441	0.48	0.65	n/a	0.1	130350	30	1.22	2.40
3.2-(a1-4)	3/4" wood furring, no EPS, 7/16" OSB, (2) #8 x 1.5" wood screws	0	319	0.296	176.5	254.5	311	278	III	0.75	0.441	0.48	0.65	0.111	0.157	115000	188	1.07	1.70
3.2-(a2-1)	3/4" wood furring, 4" EPS, 23/32" OSB, (2) 1/4"x6" lags	4	344	1.437	78	109.5	133	156.5	III	0.75	0.714	0.48	0.64	0.179	0.245	78854	51	0.65	6.75
3.2-(a2-3)	3/4" wood furring, 4" EPS, 23/32" OSB, (2) 0.135"x6" nails	4	162.5	2.863	41.5	57.5	73	72.5	IV	0.75	0.714	0.48	0.64	n/a	0.135	120348	24	0.58	6.77
3.2-(a2-4)	3/4" wood furring, no EPS, 23/32" OSB, (2) 1/4"x2" lags	0	814	0.679	199.5	499	610.5	702.5	II	0.75	0.714	0.48	0.64	0.179	0.245	90000	356	1.78	2.29
3.2-(a2-5)	3/4" wood furring, 2" EPS, 23/32" OSB, (2) 1/4"x4" lags	2	418.5	0.988	99	175.5	238	278	II	0.75	0.714	0.48	0.64	0.179	0.245	110122	104	1.05	4.02

NOTE: 3 reps each assembly, except 1 rep for 3.2-(a1-3) and 3.2-(a2-3)

Long term creep test 3.2-(a1-2), same as 3.2-(a1-1), at 104.3lbs applied load(52 lbs per #8 wood screw), resulted in about 0.025" increase in total deflection over 30 days and was levelling off.

Long term creep test 3.2-(a2-2), same as 3.2-(a2-1), at 126.5 lbs applied load (63 lbs per lag), resulted in about 0.15" increase in total deflection over 30 days and was levelling off.

wood furring to wood studs (wood-to-wood connections with and without gap):

Test ID	Description	gap (foam) inches	Max Load per Fastener (lbs)	Defl. @ Max. Load (in.)	Average Load (lbs) per Fastener at Deflections:				Failure Mode	Material Properties & Dimensions (averaged)						Fyb (fastener) psi	5% offset (lbs)	5% offset to 0.015"	Safety Margin
					0.015"	0.125"	0.250"	0.375"		t1 (furring) inches	t2 (stud) inches	G (furring) sp. Grav.	G (stud) sp. grav.	d-min inches	d-max inches				
3.2-(c1)	3/4" wood furring, 1" EPS, 2x4 wood stud, (2) 0.135"x3.5" nails	1	508	1.753	98	184	236.5	291	IV	0.75	1.75	0.48	0.44	n/a	0.134	107539	77	0.79	6.60
3.2-(c2)	3/4" wood furring, 4" EPS, 2x4 wood stud, (2) 1/4"x7" Lags	4	549.5	2.207	64	101	137.5	171.5	III	0.75	2.25	0.48	0.44	0.179	0.238	98434	53	0.83	10.37

NOTE: 1 rep each assembly (comparatives with wood studs)

Supplemental Tests by Foam Sheathing Coalition of Cladding Connections to Wood Studs (PEI, 2010b)																			
FSC TESTING -- wood furring to wood studs (wood-to-wood connections with and without gap):																			
Test ID	Description	gap (foam) inches	Max Load per Fastener (lbs)	Defl. @ Max. Load (in.)	Average Load (lbs) per Fastener at Deflections:				Failure Mode	Material Properties & Dimensions (averaged)						Fyb (fastener) psi	Predicted RATIO NDS/TR1 Predicted Safety Margin		
					0.015"	0.125"	0.250"	0.375"		t1 (furring) inches	t2 (stud) inches	G (furring) sp. Grav.	G (stud) sp. grav.	d-min inches	d-max inches		5% yield	5% offset	5% offset Margin
a1-screw	3/4" wood furring, (2) #8 wood screw, no foam	0	470	0.67	190	321	377	415	III	0.75	1.25	0.44	0.46	0.106	0.165	204204	187	0.98	2.51
a2-screw	3/4" wood furring, (2) #8 wood screw, 1" EPS foam	1	428	1.116	60	119	169	215	III	0.75	1.25	0.44	0.46	0.115	0.16	115000	79	1.32	5.42
a3-nail	3/4" wood furring, (2) 16d box (0.135"x3.5") nail, no foam	0	686	1.126	177	362	460	538	III	0.75	2.75	0.44	0.46	0.134	0.134	107539	178	1.01	3.85
a4-nail	3/4" wood furring, (2) 16d box (0.135"x3.5") nail, 1" EPS	1	503	1.515	51	128	183	242	III	0.75	1.75	0.44	0.46	0.134	0.134	107539	75	1.47	6.71
a5-nail	3/4" wood furring, (2) 0.135x4" foundry nail, 2" EPS	2	179	1.532	70	100	116	127	III	0.75	1.25	0.44	0.46	0.135	0.135	120348	47	0.67	3.81
a6-nail	3/4" wood furring, (2) 0.135x6" foundry nails, 4" EPS	4	184	1.87	46	71	98	119	III	0.75	1.25	0.44	0.46	0.135	0.135	120348	24	0.52	7.67
a7-lag	3/4" wood furring, (2) 1/4x2" lag screws, no foam	0	933	0.639	170	505	654	784	II	0.75	1.25	0.44	0.46	0.18	0.238	90000	309	1.82	3.02
a8-lag	3/4" wood furring, (2) 1/4x3" lag screws, 1" EPS	1	745	1.225	69	168	243	309	IV	0.75	1.25	0.44	0.46	0.18	0.238	88724	138	2.00	5.40
a9-lag	3/4" wood furring, (2) 1/4x4" lag screws, 2" EPS	2	649	1.536	91	161	209	248	III	0.75	1.25	0.44	0.46	0.18	0.238	110122	93	1.02	6.98
a10-lag	3/4" wood furring, (2) 1/4x6" lag screws, 4" EPS	4	551	2.505	48	78	103	127	III	0.75	1.25	0.44	0.46	0.18	0.238	78,654	45	0.94	12.24
b1-nail	3/8" wood furring, (2) 8d box (0.113x2.5") nails, no foam	0	221	0.238	98	204	219	221	III	0.375	2.13	0.44	0.46	0.114	0.114	124512	117	1.19	1.89
b2-nail	3/8" wood furring, (2) 8d box (0.113x2.5") nails, 1/2" EPS	0.5	161	0.982	77	120	138	144	IV	0.375	1.63	0.44	0.46	0.114	0.114	124512	58	0.75	2.78
b3-nail	3/8" wood furring, (2) 8d box (0.113x2.5") nails, 1" EPS	1	125	1.036	39.5	67	86	94	III	0.375	1.13	0.44	0.46	0.114	0.114	124512	36	0.91	3.47
b4-nail	3/8" wood furring, (2) 16d box (0.135x3.5") nails, 1" EPS	1	288	0.73	55	96	125	168	III	0.375	2.13	0.44	0.46	0.134	0.134	107539	48	0.87	6.00
b5-nail	3/8" wood furring, (2) 16d (0.135x4") foundry nails, 2" EPS	2	155	1.121	56	77	95	104	III	0.375	1.63	0.44	0.46	0.135	0.135	120348	30	0.54	5.17

**APPENDIX D
ICC MODEL BUILDING CODE PROPOSALS FOR 2012 IBC AND IRC**

APPENDIX D – ICC Model Building Code Proposals for 2012 IBC and IRC

The following code proposals seek to amend the 2009 editions of the following model codes: International Building Code (IBC) and International Residential Code (IRC) available at www.iccsafe.org. These proposals are public comments modifying the original proposals which include additional items as noted below in the public comments. The tables in each proposal with specific fastener requirements reflect the work conducted under this project. The other text is necessary to fit the tables into the ICC code formats. Similarly, the tables should be fit into a format consistent with the New York State Building and Residential Codes.

FS156-09/10 (PART 1) – IBC
202

Individual Consideration Agenda

This item is on the agenda for individual consideration because a public comment was submitted.

Public Comment:

Name: Jay H. Crandell, P.E. (ARES Consulting, representing Foam Sheathing Coalition) & Mark Nowak (representing Steel Framing Alliance)

Modify the proposal as follows (Only if AMPC is desired. If no modification is requested, enter your reason statement in “Commenter’s Reason”):

1. *Revise Item 1 in original proposal as follows:*

1404.12 Foam plastic sheathing. Foam plastic sheathing shall comply with requirements for foam plastic insulation in Section 2603. When used as a water-resistive barrier, the foam plastic sheathing material and installation shall be approved in accordance with Section 1404.2. When used in exterior wall covering assemblies in accordance with Table 1405.18.1 of Section 1405.18.1, foam sheathing shall be identified by the trademarks of an approved testing and inspection agency in accordance with Section 1703 and 2603.2 indicating compliance with the wind pressure resistance requirements of Table 1405.18.1 where not already addressed in the applicable material standards.

2. *(No change to Item 2 of original proposal)*

3. *Revise Item 3 of original proposal as follows:*

1405.18 Foam plastic sheathing. Foam plastic sheathing used in exterior wall covering assemblies shall comply with this section, Section 2603, Chapter 13, and the foam sheathing manufacturer’s approved installation instructions. Wall assemblies with foam plastic sheathing that are intended to serve as part of the lateral force resisting system of a structure shall be braced with approved materials designed to resist the in-plane shear force determined in accordance with Chapter 16. Wall assemblies with foam plastic sheathing attached to gravity load supporting members that require buckling restraint shall have such restraint provided by other approved

materials. The use of foam plastic sheathing in accordance with this section shall not be permitted where the basic wind speed exceeds 110 mph.

~~1405.18.1 Minimum thickness. The thickness of foam plastic sheathing shall comply with Table 1405.18.1.~~

Exceptions:

1. Where foam plastic sheathing is covered with applied directly over or behind wall sheathing or other solid material substrate capable of separately resisting the required wind pressure, the limitations of Section 1405.18.1 and the basic wind speed limit of 110 mph Table 1405.18.1 shall not apply.
2. Where foam plastic sheathing is covered with cladding and applied directly over wall sheathing or other solid material, all capable of separately resisting the full design wind pressure, the limitations of Section 1405.18.1 and the basic wind speed limit of 110 mph shall not apply.

1405.18.1 Minimum thickness. The thickness of foam plastic sheathing shall comply with Table 1405.18.1. The components and cladding design wind pressure determined in accordance with Section 1609 shall not exceed the allowable wind pressure value in accordance with Table 1405.18.1.

(Delete and replace Table 1405.18.1 with the following):

**TABLE 1405.18.1
ALLOWABLE WIND PRESSURE VALUE (PSF) FOR FOAM PLASTIC SHEATHING
IN EXTERIOR WALL COVERING ASSEMBLIES¹**

<u>Foam Plastic Sheathing Material²</u>	<u>Foam Sheathing Thickness (in)</u>	<u>Allowable (ASD) Components and Cladding Design Wind Pressure (psf)</u> <u>(basic wind speed not to exceed 110 mph per Section 1405.18)</u>			
		<u>Walls with Interior Finish³</u>		<u>Walls without Interior Finish</u>	
		<u>16"oc framing</u>	<u>24"oc framing</u>	<u>16"oc framing</u>	<u>24"oc framing</u>
<u>EPS</u>	<u>3/4"</u>	<u>21.8</u>	<u>NP</u>	<u>15.3</u>	<u>NP</u>
	<u>1"</u>	<u>38.8</u>	<u>19.4</u>	<u>27.2</u>	<u>13.6</u>
	<u>≥1-1/2"</u>	<u>89.0</u>	<u>39.5</u>	<u>62.3</u>	<u>27.7</u>
<u>Polyiso-cyanurate</u>	<u>1/2" (faced)</u>	<u>33.3</u>	<u>14.8</u>	<u>23.3</u>	<u>10.4</u>
	<u>3/4" (faced)</u>	<u>56.4</u>	<u>25.1</u>	<u>39.5</u>	<u>17.6</u>
	<u>1" (faced)</u>	<u>67.5</u>	<u>30.0</u>	<u>47.2</u>	<u>21.0</u>
	<u>≥1-1/2" (faced)</u>	<u>77.4</u>	<u>34.4</u>	<u>54.1</u>	<u>24.1</u>
<u>XPS</u>	<u>1/2" (faced)</u>	<u>28.3</u>	<u>12.6</u>	<u>19.8</u>	<u>NP</u>
	<u>3/4"</u>	<u>21.4</u>	<u>NP</u>	<u>15.0</u>	<u>NP</u>
	<u>1"</u>	<u>38.0</u>	<u>29.0</u>	<u>26.6</u>	<u>20.3</u>
	<u>≥1-1/2"</u>	<u>78.2</u>	<u>34.7</u>	<u>54.7</u>	<u>24.3</u>

For SI: 1 inch = 25.4 mm, 1 pound per square foot (psf) = 0.0479 kPa.

NP = not permitted (allowable design wind pressure less than 10 psf)

1. Foam plastic sheathing panels shall be permitted to be oriented parallel or perpendicular to framing members.
2. Foam plastic sheathing shall meet or exceed the following material standards: Expanded Polystyrene (EPS) – ASTM C578 (Type II, min.1.35 lb/ft³ density), Polyisocyanurate – ASTM C1289 (Type 1, min.), and extruded polystyrene (XPS) – ASTM C578 (Type X, min. 1.30 lb/ft³ density). Where a “faced” product is indicated, a facer shall be provided on both faces of the foam plastic sheathing. Where facing is not indicated in the table, faced and unfaced foam plastic sheathing shall be permitted. For all foam plastic sheathing products, approved manufacturer data shall be permitted in lieu of the table requirements.
3. Interior finish shall be minimum 1/2-inch (12.7 mm) thick gypsum wall board or an approved product with equivalent or greater out-of-plane bending strength and stiffness.

1405.18.2 Siding attachment over foam sheathing. Siding shall be attached over foam sheathing in accordance with Section 1405.18.2.1, Section 1405.18.2.2, or an approved design. In no case shall the siding material be used in a manner that exceeds its application limits. When required by the basic wind speed and wind exposure applicability of Section 1706, wall cladding installation over foam sheathing shall be subject to special inspection in accordance with Section 1706.4.

Exception: Where the siding manufacturer has provided approved installation instructions for application over foam sheathing, those requirements shall apply.

1405.18.2.1 Direct siding attachment. Approved weather coverings installed directly over foam sheathing without separation by an air space shall comply with Table 1405.18.2.1 in regard to minimum fastening requirements nail diameter, penetration, and nail spacing and maximum foam sheathing thickness limitations to support siding dead load for the applicable foam sheathing thickness and wind speed condition. The siding fastener and siding installation shall otherwise comply with Chapter 14, shall be capable of resisting all other applicable design loads determined in accordance with Chapter 16, and in no case shall result in a less stringent fastening requirement than required by Chapter 14 or the manufacturer’s installation instructions for the specific siding material used.

Exceptions:

- ~~1. For adhered masonry veneer, refer to Section 1405.10.~~
- ~~2. For vinyl siding, refer to Section 1405.14.~~
- ~~3. For exterior insulation and finish systems, refer to Section 1408.~~

Replace Table 1405.18.2.1 and footnotes with the following:

**TABLE 1405.18.2.1
SIDING MINIMUM FASTENING REQUIREMENTS
FOR DIRECT SIDING ATTACHMENT OVER FOAM PLASTIC SHEATHING
TO SUPPORT SIDING DEAD LOAD¹**

Siding Fastener Through Foam Sheathing into:	Siding Fastener Type and Minimum Size ²	Siding Fastener Vertical Spacing (inches)	Maximum Foam Sheathing Thickness (inches)					
			16"oc Fastener Horizontal Spacing			24"oc Fastener Horizontal Spacing		
			Siding Weight:			Siding Weight:		
			3 psf	11 psf	25 psf	3 psf	11 psf	25 psf
Wood Framing (minimum 1-1/4 inch penetration)	0.113" diameter nail	6	4	3	1	4	2	0.75
		8	4	2	0.75	4	1.5	DR
		12	4	1.5	DR	3	0.75	DR
	0.120" diameter nail	6	4	3	1.5	4	2	0.75
		8	4	2	1	4	1.5	0.5
		12	4	1.5	0.5	3	1	DR
	0.131" diameter nail	6	4	4	1.5	4	3	1
		8	4	3	1	4	2	0.75
		12	4	2	0.75	4	1	DR
Steel Framing (minimum penetration of steel thickness + 3 threads)	#8 screw into 33 mil steel or thicker	6	3	3	1.5	3	2	DR
		8	3	2	0.5	3	1.5	DR
		12	3	1.5	DR	3	0.75	DR
	#10 screw into 33 mil steel	6	4	3	2	4	3	0.5
		8	4	3	1	4	2	DR
		12	4	2	DR	3	1	DR
	#10 screw into 43 mil steel or thicker	6	4	4	3	4	4	2
		8	4	4	2	4	3	1.5
		12	4	3	1.5	4	3	DR

For SI: 1 inch = 25.4 mm; 1 pound per square foot (psf) = 0.0479 kPa

DR = design required

4. Tabulated requirements are based on wood framing of Spruce-Pine-Fir or any wood species with a specific gravity of 0.42 or greater in accordance with AFPA/NDS and minimum 33 ksi steel for 33 mil and 43 mil steel and 50 ksi steel for 54 mil steel or thicker.
5. Nail fasteners shall comply with ASTM F1667, except nail length shall be permitted to exceed ASTM F1667 standard lengths. Self-drilling tapping screw fasteners for connection of siding to steel framing shall comply with the requirements of AISI S200. Specified fasteners in accordance with Chapter 1405 or the siding manufacturer's approved installation instructions shall meet all other requirements in ASTM F1667, AISI S200 or be otherwise approved for the intended application.

1405.18.2.2 Offset siding attachment. When an airspace separates the siding from direct contact with the foam plastic sheathing, the approved weather coverings shall be attached in accordance with Chapter 14 to minimum 1x3 wood or minimum 33 mil steel hat channel furring strips placed over the foam sheathing. Furring shall be attached through the foam sheathing to wall framing in accordance with Table 1405.18.2.2 in regard to minimum fastening requirements and maximum foam sheathing thickness limitations to support siding dead load. Furring and connections shall be separately designed to resist all other applicable loads determined in accordance with Chapter 16. When placed horizontally, wood furring strips shall be preservative treated wood in accordance with Section 2303.1.8 or naturally durable wood and fasteners shall be corrosion resistant in accordance with Section 2304.9.5. Steel hat channel furring shall have a minimum G60 galvanized coating.

Exception: Furring strips shall not be required over foam plastic sheathing behind anchored stone and masonry veneer installed in accordance with Section 1405.6. Veneer ties shall be installed on the surface of the foam plastic sheathing with fasteners of sufficient length to pass through the thickness of foam plastic sheathing and penetrate framing to provide required pull-out resistance determined in accordance with Chapter 16.

Replace Table 1405.18.2.2 and footnotes with the following:

TABLE 1405.18.2.2
FURRING MINIMUM FASTENING REQUIREMENTS FOR APPLICATION
OVER FOAM PLASTIC SHEATHING TO SUPPORT SIDING DEAD LOAD^{1,2}

Furring Material	Framing Member	Fastener Type and Minimum Size	Minimum Penetration into Wall Framing (inches)	Fastener Spacing in Furring (inches)	Maximum Thickness of Foam Sheathing (inches)					
					16"oc FURRING ⁴			24"oc FURRING ⁴		
					Siding Weight:			Siding Weight:		
					3 psf	11 psf	25 psf	3 psf	11 psf	25 psf
Minimum 1x Wood Furring ³	Minimum 2x Wood Stud	0.120" diameter nail	1-1/4	8	4	4	1.5	4	2	1
				12	4	2	1	4	1.5	0.5
				16	4	2	0.5	4	1	DR
		0.131" diameter nail	1-1/4	8	4	4	2	4	3	1
				12	4	3	1	4	2	0.7/5
				16	4	2	0.7/5	4	1.5	DR
		#8 wood screw ⁵	1	12	4	4	1.5	4	3	1
				16	4	3	1	4	2	0.5
				24	4	2	0.5	4	1	DR
		1/4" lag screw ⁵	1-1/2	12	4	4	3	4	4	1.5
				16	4	4	2	4	3	1
				24	4	3	1	4	2	0.5
Minimum 33mil Steel Hat Channel or Minimum 1x Wood Furring ³	33 mil Steel Stud	#8 screw	Steel thickness + 3 threads	12	3	1.5	DR	3	0.5	DR
				16	3	1	DR	2	DR	DR
				24	2	DR	DR	2	DR	DR
		#10 screw	Steel thickness + 3 threads	12	4	2	DR	4	1	DR
				16	4	1.5	DR	3	DR	DR
				24	3	DR	DR	2	DR	DR
	43 mil or thicker Steel Stud	#8 Screw	Steel thickness + 3 threads	12	3	1.5	DR	3	0.5	DR
				16	3	1	DR	2	DR	DR
				24	2	DR	DR	2	DR	DR
		#10 screw	Steel thickness + 3 threads	12	4	3	1.5	4	3	DR
				16	4	3	0.5	4	2	DR
				24	4	2	DR	4	0.5	DR

For SI: 1" = 25.4 mm; 1 pound per square foot (psf) = 0.0479 kPa.

DR = design required

1. Table values are based on: (1) minimum 3/4-inch (19.1 mm) thick wood furring and wood studs of Spruce-Pine-Fir or any softwood species with a specific gravity of 0.42 or greater per AFPA/NDS, (2) minimum 33 mil steel hat channel furring of 33 ksi steel, and (3) steel framing of indicated nominal steel thickness and minimum 33 ksi steel for 33mil and 43 mil steel and 50 ksi steel for 54 mil steel or thicker.
2. Nail fasteners shall comply with ASTM F1667, except nail length shall be permitted to exceed ASTM F1667 standard lengths. Self-drilling tapping screw fasteners for connection of siding to steel framing shall comply with the requirements of AISI S200. Specified fasteners in accordance with Chapter 1405 or the siding manufacturer's approved installation instructions shall meet all other requirements in ASTM F1667 or AISI S200 or be otherwise approved for the intended application.
3. Where the required siding fastener penetration into wood material exceeds 3/4 inch (19.1 mm) and is not more than 1-1/2 inches (38.1 mm), a minimum 2x wood furring shall be used unless approved deformed shank siding nails or siding screws are used to provide equivalent withdrawal strength allowing connection to 1x wood furring.
4. Furring shall be spaced a maximum of 24"oc in a vertical or horizontal orientation. In a vertical orientation, furring shall be located over wall studs and attached with the required fastener spacing. In a horizontal orientation, furring strips shall be fastened at each stud intersection with a number of fasteners equivalent to the required fastener spacing. In no case shall fasteners be spaced more than 24 inches (0.6 m) apart.
5. Lag screws shall be installed with a standard cut washer. Lag screws and wood screws shall be pre-drilled in accordance with AF&PA/NDS. Approved self-drilling screws of equal or greater shear and withdrawal strength shall be permitted without pre-drilling.

4. *(No change to Item 4 of original proposal)*

5. *Revise Item 5 of original proposal as follows:*

1405.14.2 Foam Plastic Sheathing. Vinyl siding used with foam plastic sheathing shall be installed in accordance with 1405.14.2.1, 1405.14.2.2, 1405.14.2.3.

Exception: Where the foam plastic sheathing is applied directly over wood structural panels, fiberboard, gypsum sheathing, or other approved backing capable of independently resisting the design wind pressure, the vinyl siding shall be installed in accordance with 1405.14.1.

1405.14.2.1 Basic Wind Speed Not Exceeding 90 mph and Exposure Category B. Where the building mean roof height does not exceed 30 feet (9.1 m), the basic wind speed does not exceed 90 mph, the Exposure Category is B and gypsum wall board or equivalent is installed on the side of the wall opposite the foam plastic sheathing, the minimum siding fastener penetration into wood framing shall be 1-1/4 inches (32 mm) using minimum 0.120-inch diameter nail (shank) with a minimum 0.313-inch diameter head, and fastened 16 inches on center. The foam plastic sheathing shall comply with Section 1405.18.1 and shall not exceed a maximum thickness of 1.5 inches (38 mm) for a 0.120-inch diameter nail or 2.0 inches (51 mm) for a 0.135-inch diameter nail. Vinyl siding shall be permitted to be installed on furring strips in accordance with Section 1405.18.2.2 and the siding manufacturer's installation instructions when foam plastic sheathing thickness complies with Section 1405.18.1.

1405.14.2.2 Basic Wind Speed Exceeding 90mph or Exposure Categories C and D. Where the basic wind speed exceeds 90 mph or the Exposure Category is C or D, or all conditions of 1405.14.2.1 are not met, the adjusted design pressure rating for the assembly shall meet or exceed the wind loads required by Chapter 16. The design wind pressure rating of the vinyl siding for installation over solid sheathing as provided in the vinyl siding manufacturer's product specifications shall be adjusted for the following wall assembly conditions:

1. For wall assemblies with foam plastic sheathing on the exterior side and minimum ½-inch (12.7 mm) thick gypsum wall board or equivalent on the interior side of the wall, the vinyl siding's design wind pressure rating shall be multiplied by 0.39.
2. For wall assemblies with foam plastic sheathing on the exterior side and no gypsum wall board or equivalent on the interior side of wall, the vinyl siding's design wind pressure rating shall be multiplied by 0.27.

~~**Exception:** The above adjustments shall not apply when vinyl siding is attached to wood furring strips installed over the foam plastic sheathing in accordance with Section 1405.18.2.2 and such installation is in accordance with the vinyl siding manufacturer's installation instructions.~~

1405.14.2.3 Manufacturer Specification. Where the vinyl siding manufacturer's product specifications provide an approved design wind pressure rating for installation over foam plastic sheathing, use of this design wind pressure rating shall be permitted and the siding shall be installed in accordance with the manufacturer's installation instructions.

6. *(No change to Item 6 of original proposal)*

Commenter's Reason:

This public comment responds to constructive criticism and supportive recommendations received at the first hearing. Every effort has been made to follow-up with the various interests and to respond with improvements to the original proposal. These improvements are also coordinated with a complimentary PC on FS156-09/10 Part 2 (IRC) as also requested by the IRC CDC which approved the original proposal with a request for further refinements at Final Action. These refinements are coordinated and comprehensively made in this one PC for reasons addressed separately as follows:

Inclusion of Steel Framing

Tables 1405.18.2.1 and 1405.18.2.2 now include siding connections for use with light-frame cold-formed steel in addition to light-frame wood as requested at the first hearing. These are needed to provide siding connection solutions applicable to light-frame cold-formed steel construction to ensure coordination with IECC energy code requirements for this type of construction (as mentioned in the IBC-S committee's reason for disapproval). The Steel Framing Alliance (SFA), American Iron and Steel Institute (AISI), and the Foam Sheathing Coalition (FSC) have worked together toward this end.

The original proposal included connection solutions for attachment of siding over foam sheathing only for wood framing. But, the scope of the original proposal was not otherwise limited to wood framing (i.e., requirements in Table 1405.18.1 of the original proposal are applicable to both wood and steel framing). The IRC committee approved the original FS156-09/10 proposal, but also expressed concern to “work with industry and bring the needed improvement back to the Final Action.”

Steel framing was not addressed in the original proposal only because test data was not available at that time to justify appropriate solutions. Subsequently, the steel industry together with New York State Research and Energy Development Authority (NYSERDA) has conducted a testing program to provide justification to the solutions proposed in this PC. A report on this testing will be made available at the Final Action hearing and, as soon as available, by request to the proponent (Mark Nowak, SFA, mnowak@steelframing.org). These tests provide the necessary performance data for appropriately designing siding connections to steel framing that span through a thickness of foam sheathing.

These proposed provisions for light-frame cold-formed steel construction are not only coordinated with ICC energy code requirements, but they are necessary to ensure that foam insulation requirements as required by the ICC energy code are implemented in a structurally sound manner. Support of this PC is urged.

Inclusion of Additional Siding Weight Categories:

The original proposal was based on a minimum 11 psf siding dead load (for siding attachment requirements over foam sheathing). While various siding manufacturers supported the original proposal (or remained neutral), several expressed the desire to be included, such as the Masonry Veneer Manufacturers Association. Thus, a 25 psf siding weight category and connection requirements have been included in this PC. This also required inclusion of a 3 psf siding weight category such that the lighter weight sidings would not be unduly penalized by basing the table only on heavier siding types.

Simplification, Clarification and Editorial Improvements:

- Content from table footnotes moved into tables for visual clarity and ease of access.
- Removed confusing wind speed requirements from siding attachment table otherwise intending to address connection requirements for support of siding dead load and limit foam thickness. The text is clarified to more explicitly require that the siding attachment be separately designed to resist other loading conditions, including wind.
- Adjusted fastener sizes to be compatible with pneumatic fasteners at request of ISANTA
- Various editorial improvements to language, table headings, etc.

Additional technical justification for siding connections over foam sheathing

The FSC has also done additional testing of siding over foam sheathing connection assemblies for attachments to wood framing. These tests add further confirmation of the adequacy of the proposed siding attachment requirements for wood framing and support of siding weight. It also

confirms that siding deflections will be limited to less than 0.015” as commonly used as a design basis for wood connections. A report documenting this testing will also be made available at the final action hearing and will be posted at www.foamsheathing.org as soon as available.

Strengthened QC requirements for foam sheathing wind pressure resistance properties

One of the concerns raised at the first code development hearing on FS156 was related to having assurance that foam sheathing products meet the wind pressure performance requirements upon which the proposal (namely Table 1405.18.1) is based. This public comment addresses that concern by clarifying implementation a code-recognized “approved agency” approach that already exists and is commonly used for foam sheathing and other products.

First, 2009 IBC Section 2603.2 gives foam plastic insulation requirements for use of an approved agency and labeling to ensure end use complies with code requirements as follows:

2603.2 Labeling and identification. Packages and containers of foam plastic insulation and foam plastic insulation components delivered to the job site shall bear the *label* of an *approved agency* showing the manufacturer’s name, product listing, product identification and information sufficient to determine that the end use will comply with the code requirements.

Second, 2009 IBC Section 2603.5.4 provides an example of product performance criteria (test method and minimum performance indices) which the “approved agency” must consider in meeting the requirements of Section 2603.2:

2603.5.4 Flame spread and smoke-developed indexes. Foam plastic insulation, exterior coatings and facings shall be tested separately in the thickness intended for use, but not to exceed 4 inches (102 mm), and shall each have a flame spread index of 25 or less and a smoke-developed index of 450 or less as determined in accordance with ASTM E 84 or UL 723.

Third, the Approved Agency is defined in Sections 202 and 1702.1 of the 2009 IBC as follows:

APPROVED AGENCY. An established and recognized agency regularly engaged in conducting tests or furnishing inspection services, when such agency has been *approved*.

And, the responsibilities of the Approved Agency include:

1703.1 Approved agency. An *approved agency* shall provide all information as necessary for the *building official* to determine that the agency meets the applicable requirements.

1703.1.1 Independence. An *approved agency* shall be objective, competent and independent from the contractor responsible for the work being inspected. The agency shall also disclose possible conflicts of interest so that objectivity can be confirmed.

1703.5 Labeling. Where materials or assemblies are required by this code to be *labeled*, such materials and assemblies shall be *labeled* by an *approved agency* in accordance with Section 1703. Products and materials required to be labeled shall be labeled in accordance with the procedures set forth in Sections 1703.5.1 through 1703.5.3.

This approach is also used for other materials such as:

2303.1.4 Wood structural panels. Wood structural panels, when used structurally (including those used for siding, roof and wall sheathing, subflooring, diaphragms and built-up members), shall conform to the requirements for their type in DOC PS 1 or PS 2. Each panel or member shall be identified or grade and glue type by the trademarks of an *approved* testing and grading agency. Wood structural panel components shall be designed and fabricated in accordance with the applicable standards listed in Section 2306.1 and identified by the trademarks of an *approved* testing and inspection agency indicating conformance with the applicable standard. In addition, wood structural panels when permanently exposed in outdoor applications shall be of exterior type, except that wood structural panel roof sheathing exposed to the outdoors on the underside is permitted to be interior type bonded with exterior glue, Exposure 1.

Additionally, a Fabricated Item is defined as follows:

FABRICATED ITEM. Structural, load-bearing or lateral load-resisting assemblies consisting of materials assembled prior to installation in a building or structure, or subjected to operations such as heat treatment, thermal cutting, cold working or reforming after manufacture and prior to installation in a building or structure. Materials produced in accordance with standard specifications referenced by this code, such as rolled structural steel shapes, steel-reinforcing bars, masonry units, and wood structural panels or in accordance with a standard, listed in Chapter 35, which provides requirements for quality control done under the supervision of a third-party quality control agency shall not be considered “fabricated items.”

The above described “approved agency” process has shown itself effective and this public comment merely clarifies the application of this process to assure the structural properties (wind pressure resistance) of foam sheathing align with the basis of the proposed end-use requirements and limitations. The minimum performance requirements are based on a representative sample of currently manufactured products of each type as reported by the NAHB Research Center, Inc. (report available at www.foamshathing.org). Support for this PC is urged.

Strengthened Scope Limitations on Foam Sheathing Applications

At the request of the insurance industry, a 110 mph wind speed limit has also been implemented in this proposal for foam sheathing. In addition, wind pressure requirements have been strengthened to require use of negative pressure values in all cases, even when siding is placed over foam sheathing and the siding is separately capable of resisting the full negative design wind pressure.

These provisions are needed for the above reasons, provide improvements for appropriate use of foam sheathing, and provide needed solutions for coordination with the energy code requirements. Again, your approval as modified is urged.

FS156-09/10 (Part 2) – IRC
202

Individual Consideration Agenda

This item is on the agenda for individual consideration because a public comment was submitted.

Public Comment:

Name: Jay H. Crandell, P.E. (ARES Consulting, rep. FSC) and Mark Nowak (rep. SFA)

Modify the proposal as follows (Only if AMPC is desired. If no modification is requested, enter your reason statement in “Committer’s Reason”):

1. Revise Item 1 of original proposal as follows:

R703.3 Foam plastic sheathing. Foam plastic sheathing used in exterior wall covering assemblies shall comply with this section, Section R316, Chapter 11 and the manufacturer’s installation instructions. Light frame wood and cold-formed steel braced wall lines including foam plastic sheathing shall be braced with approved materials in accordance with Chapter 6. Where lateral buckling restraint of light-frame wood and cold-formed steel studs also is required in Chapter 6, foam sheathing shall not be permitted to provide the required lateral buckling restraint. When used in exterior wall covering assemblies in accordance with Table 703.3.1 of Section R703.3.1, foam sheathing shall be identified by the trademarks of an *approved* testing and inspection agency in accordance with Section 316.2 indicating compliance with the wind pressure resistance requirements of Table R703.3.1 where not already addressed in the applicable material standards. The use of foam plastic sheathing in accordance with this section shall not be permitted where the basic wind speed exceeds 110 mph.

~~R703.3.1 Minimum thickness.~~ ~~The thickness of foam plastic sheathing shall comply with Table R703.3.1.~~

Exceptions:

1. Where foam plastic sheathing is covered with applied directly over or behind wall sheathing or other solid material substrate capable of separately resisting the required wind pressure, the limitations of Section R703.3.1 and the basic wind speed limit of 110 mph Table 703.3.1 shall not apply.
2. Where foam plastic sheathing is covered with cladding and applied directly over wall sheathing or other solid material, all capable of separately resisting the full design wind pressure, the limitations of Section R703.3.1 and the basic wind speed limit of 110 mph shall not apply.

R703.3.1 Minimum thickness. The thickness of foam plastic sheathing shall comply with Table R703.3.1. The components and cladding design wind pressure determined in accordance with Table R301.2(2) shall not exceed the allowable wind pressure value in accordance with Table R703.3.1.

(Delete and replace Table R703.3.1 as follows):

TABLE R703.3.1
ALLOWABLE WIND PRESSURE VALUE (PSF) FOR FOAM PLASTIC SHEATHING
IN EXTERIOR WALL COVERING ASSEMBLIES¹

Foam Plastic Sheathing Material²	Foam Sheathing Thickness (in)	Allowable (ASD) Components and Cladding Design Wind Pressure (psf) (basic wind speed not to exceed 110 mph per Section R703.3)			
		Walls with Interior Finish³		Walls without Interior Finish	
		16"oc framing	24"oc framing	16"oc framing	24"oc framing
EPS	3/4"	21.8	NP	15.3	NP
	1"	38.8	19.4	27.2	13.6
	≥1-1/2"	89.0	39.5	62.3	27.7
Polyisocyanurate	1/2" (faced)	33.3	14.8	23.3	10.4
	3/4" (faced)	56.4	25.1	39.5	17.6
	1" (faced)	67.5	30.0	47.2	21.0
	≥1-1/2" (faced)	77.4	34.4	54.1	24.1
XPS	1/2" (faced)	28.3	12.6	19.8	NP
	3/4"	21.4	NP	15.0	NP
	1"	38.0	29.0	26.6	20.3
	≥1-1/2"	78.2	34.7	54.7	24.3

For SI: 1 inch = 25.4 mm, 1 pound per square foot (psf) = 0.0479 kPa.

NP = not permitted (allowable design wind pressure less than 10 psf)

3. Foam plastic sheathing panels shall be permitted to be oriented parallel or perpendicular to framing members.
4. Foam plastic sheathing shall meet or exceed the following material standards: Expanded Polystyrene (EPS) – ASTM C578 (Type II, min.1.35 lb/ft³ density), Polyisocyanurate – ASTM C1289 (Type 1, min.), and extruded polystyrene (XPS) – ASTM C578 (Type X, min. 1.30 lb/ft³ density). Where a “faced” product is indicated, a facer shall be provided on both faces of the foam plastic sheathing. Where facing is not indicated in the table, faced and unfaced foam plastic sheathing shall be permitted. For all foam plastic sheathing products, approved manufacturer data shall be permitted in lieu of the table requirements.

3. Interior finish shall be minimum 1/2-inch (12.7 mm) thick gypsum wall board or an approved product with equivalent or greater out-of-plane bending strength and stiffness.

R703.3.2 Siding attachment over foam sheathing. Siding shall be attached over foam sheathing in accordance with Section R703.3.2.1, Section R703.3.2.2, or an approved design. In no case shall the siding material be used in a manner that exceeds its application limits.

Exception: Where the siding manufacturer has provided installation instructions for application over foam sheathing, those requirements shall apply.

R703.3.2.1 Direct siding attachment. Siding installed directly over foam sheathing without separation by an air space shall comply with Table R703.3.2.1 in regard to minimum fastening requirements nail diameter, penetration, and nail spacing and maximum foam sheathing thickness limitations to support siding dead load for the applicable foam sheathing thickness and wind speed condition. The siding fastener and siding installation shall otherwise comply with Section 703.4 and Table R703.4 and in no case shall result in a less stringent fastening requirement than required by Section R703.4 or the manufacturer's installation instructions for the specific siding material used.

Exceptions:

1. ~~For adhered masonry veneer, refer to Section 1405.10.~~
2. ~~For vinyl siding, refer to Section 1405.14.~~
3. For exterior insulation and finish systems, refer to Section 1408.

(Delete and replace Table R703.3.2.1 as follows):

TABLE R703.3.2.1
SIDING MINIMUM FASTENING REQUIREMENTS
FOR DIRECT SIDING ATTACHMENT OVER FOAM PLASTIC SHEATHING
TO SUPPORT SIDING WEIGHT¹

<u>Siding Fastener Through Foam Sheathing into:</u>	<u>Siding Fastener Type and Minimum Size²</u>	<u>Siding Fastener Vertical Spacing (inches)</u>	<u>Maximum Foam Sheathing Thickness (inches)</u>					
			<u>16"oc Fastener Horizontal Spacing</u>			<u>24"oc Fastener Horizontal Spacing</u>		
			<u>Siding Weight:</u>			<u>Siding Weight:</u>		
			<u>3 psf</u>	<u>11 psf</u>	<u>25 psf</u>	<u>3 psf</u>	<u>11 psf</u>	<u>25 psf</u>
<u>Wood Framing (minimum 1-1/4 inch penetration)</u>	<u>0.113" diameter nail</u>	<u>6</u>	<u>4</u>	<u>3</u>	<u>1</u>	<u>4</u>	<u>2</u>	<u>0.75</u>
		<u>8</u>	<u>4</u>	<u>2</u>	<u>0.75</u>	<u>4</u>	<u>1.5</u>	<u>DR</u>
		<u>12</u>	<u>4</u>	<u>1.5</u>	<u>DR</u>	<u>3</u>	<u>0.75</u>	<u>DR</u>
	<u>0.120" diameter nail</u>	<u>6</u>	<u>4</u>	<u>3</u>	<u>1.5</u>	<u>4</u>	<u>2</u>	<u>0.75</u>
		<u>8</u>	<u>4</u>	<u>2</u>	<u>1</u>	<u>4</u>	<u>1.5</u>	<u>0.5</u>
		<u>12</u>	<u>4</u>	<u>1.5</u>	<u>0.5</u>	<u>3</u>	<u>1</u>	<u>DR</u>
	<u>0.131" diameter nail</u>	<u>6</u>	<u>4</u>	<u>4</u>	<u>1.5</u>	<u>4</u>	<u>3</u>	<u>1</u>
		<u>8</u>	<u>4</u>	<u>3</u>	<u>1</u>	<u>4</u>	<u>2</u>	<u>0.75</u>
		<u>12</u>	<u>4</u>	<u>2</u>	<u>0.75</u>	<u>4</u>	<u>1</u>	<u>DR</u>
<u>Steel Framing (minimum penetration of steel thickness + 3 threads)</u>	<u>#8 screw into 33 mil steel or thicker</u>	<u>6</u>	<u>3</u>	<u>3</u>	<u>1.5</u>	<u>3</u>	<u>2</u>	<u>DR</u>
		<u>8</u>	<u>3</u>	<u>2</u>	<u>0.5</u>	<u>3</u>	<u>1.5</u>	<u>DR</u>
		<u>12</u>	<u>3</u>	<u>1.5</u>	<u>DR</u>	<u>3</u>	<u>0.75</u>	<u>DR</u>
	<u>#10 screw into 33 mil steel</u>	<u>6</u>	<u>4</u>	<u>3</u>	<u>2</u>	<u>4</u>	<u>3</u>	<u>0.5</u>
		<u>8</u>	<u>4</u>	<u>3</u>	<u>1</u>	<u>4</u>	<u>2</u>	<u>DR</u>
		<u>12</u>	<u>4</u>	<u>2</u>	<u>DR</u>	<u>3</u>	<u>1</u>	<u>DR</u>
	<u>#10 screw into 43 mil steel or thicker</u>	<u>6</u>	<u>4</u>	<u>4</u>	<u>3</u>	<u>4</u>	<u>4</u>	<u>2</u>
		<u>8</u>	<u>4</u>	<u>4</u>	<u>2</u>	<u>4</u>	<u>3</u>	<u>1.5</u>
		<u>12</u>	<u>4</u>	<u>3</u>	<u>1.5</u>	<u>4</u>	<u>3</u>	<u>DR</u>

For SI: 1 inch = 25.4 mm; 1 pound per square foot (psf) = 0.0479 kPa.

DR = design required

1. Tabulated requirements are based on wood framing of Spruce-Pine-Fir or any wood species with a specific gravity of 0.42 or greater in accordance with AFPA/NDS and minimum 33 ksi steel for 33mil and 43 mil steel and 50 ksi steel for 54 mil steel or thicker.
2. Nail fasteners shall comply with ASTM F1667, except nail length shall be permitted to exceed ASTM F1667 standard lengths. Self-drilling tapping screw fasteners for connection of siding to steel framing shall comply with the requirements of AISI S230. Specified fasteners in accordance with Section R703.4 or the siding manufacturer's approved installation instructions shall meet all other requirements in ASTM F1667, AISI S230 or be otherwise approved for the intended application.

R703.3.2.2 Offset siding attachment. When an airspace separates the siding from direct contact with the foam plastic sheathing, the siding shall be attached in accordance with Section R703.4 and Table R703.4 to minimum 1x3 wood or minimum 33 mil steel hat channel furring strips placed over the foam sheathing. Furring shall be attached through the foam sheathing to wall framing in accordance with Table R703.3.2.2 in regard to minimum fastening requirements and maximum foam sheathing thickness limitations to support siding dead load. The components and cladding design wind pressure determined in accordance with Table R301.2(2) shall not exceed the allowable design wind pressure value in accordance with Table R703.3.2.2. For 25 psf siding weight in accordance with Table R703.3.2.2, the Seismic Design Category shall not exceed D₀ for 16”oc furring or C for 24”oc furring. When placed horizontally, wood furring strips shall be preservative treated wood or naturally durable wood and fasteners shall be corrosion resistant in accordance with Section R317. Steel hat channel furring shall have a minimum G60 galvanized coating.

Exception: Furring strips shall not be required over foam plastic sheathing located behind anchored stone and masonry veneer installed in accordance with Section R703.7. Veneer ties shall be installed in accordance with Section R703.7.4.1.

(Delete and replace Table R703.3.2.2 as follows):

TABLE R703.3.2.2
FURRING MINIMUM FASTENING REQUIREMENTS
FOR APPLICATION OVER FOAM PLASTIC SHEATHING
TO SUPPORT SIDING WEIGHT^{1,2}

Furring Material	Framing Member	Fastener Type and Minimum Size	Minimum Penetration into Wall Framing (inches)	Fastener Spacing in Furring (inches)	Maximum Thickness of Foam Sheathing (inches)						Allowable Design Wind Pressure (psf)	
					16"oc Furring ⁴			24"oc Furring ⁴			16"oc Furring	24"oc Furring
					Siding Weight:			Siding Weight:				
3 psf	11 psf	25 psf	3 psf	11 psf	25 psf	g	g					
Minimum 1x Wood Furring ³	Minimum 2x Wood Stud	Nail (0.120" shank; 0.271" head)	1-1/4	8	4	4	1.5	4	2	1	42.6	28.4
				12	4	2	1	4	1.5	0.5	28.4	18.9
				16	4	2	0.5	4	1	DR	21.3	14.2
		Nail (0.131" shank; 0.281" head)	1-1/4	8	4	4	2	4	3	1	46.5	31.0
				12	4	3	1	4	2	0.75	31.0	20.7
				16	4	2	0.75	4	1.5	DR	23.3	15.5
	#8 wood screw ⁵	1	12	4	4	1.5	4	3	1	98.9	66.0	
			16	4	3	1	4	2	0.5	74.2	49.5	
			24	4	2	0.5	4	1	DR	35.1	23.4	
		1/4" lag screw ⁵	1-1/2	12	4	4	3	4	4	1.5	140.4	93.6
				16	4	4	2	4	3	1	79.0	52.7
				24	4	3	1	4	2	0.5	35.1	23.4
Minimum 33mil Steel Hat Channel or Minimum 1x Wood Furring ³	33 mil Steel Stud	#8 screw (0.285" head)	Steel thickness +3 threads	12	3	1.5	DR	3	0.5	DR	52.9	35.3
				16	3	1	DR	2	DR	DR	39.7	26.5
				24	2	DR	DR	2	DR	DR	26.5	17.6
		#10 screw (0.333" head)	Steel thickness +3 threads	12	4	2	DR	4	1	DR	62.9	41.9
				16	4	1.5	DR	3	DR	DR	47.1	31.4
				24	3	DR	DR	2	DR	DR	31.4	21.0
	43 mil or thicker Steel Stud	#8 screw (0.285" head)	Steel thickness +3 threads	12	3	1.5	DR	3	0.5	DR	69.0	46.0
				16	3	1	DR	2	DR	DR	51.8	34.5
				24	2	DR	DR	2	DR	DR	34.5	23.0
		#10 screw (0.333" head)	Steel thickness +3 threads	12	4	3	1.5	4	3	DR	81.9	54.6
				16	4	3	0.5	4	2	DR	61.5	41.0
				24	4	2	DR	4	0.5	DR	35.1	23.4

For SI: 1" = 25.4 mm; 1 pound per square foot (psf) = 0.0479 kPa. DR = design required

7. Table values are based on: (1) minimum 3/4-inch (19.1 mm) thick wood furring and wood studs of Spruce-Pine-Fir or any softwood species with a specific gravity of 0.42 or greater

per AFPA/NDS, (2) minimum 33 mil steel hat channel furring of 33 ksi steel, and (3) steel framing of indicated nominal steel thickness and minimum 33 ksi steel for 33mil and 43 mil steel and 50 ksi steel for 54 mil steel or thicker. Steel hat channel shall have a minimum 7/8-inch (22.2 mm) depth.

8. Nail fasteners shall comply with ASTM F1667, except nail length shall be permitted to exceed ASTM F1667 standard lengths. Self-drilling tapping screw fasteners for connection of siding to steel framing shall comply with the requirements of AISI S230. Specified fasteners in accordance with Section R703.4 or the siding manufacturer's approved installation instructions shall meet all other requirements in ASTM F1667 or AISI S230 or be otherwise approved for the intended application.
9. Where the required siding fastener penetration into wood material exceeds 3/4 inch (19.1 mm) and is not more than 1-1/2 inches (38.1 mm), a minimum 2x wood furring shall be used unless approved deformed shank siding nails or siding screws are used to provide equivalent withdrawal strength allowing connection to 1x wood furring.
10. Furring shall be spaced a maximum of 24"oc in a vertical or horizontal orientation. In a vertical orientation, furring shall be located over wall studs and attached with the required fastener spacing. In a horizontal orientation, furring strips shall be fastened at each stud intersection with a number of fasteners equivalent to the required fastener spacing. In no case shall fasteners be spaced more than 24 inches (0.6 m) apart.
11. Lag screws shall be installed with a standard cut washer. Lag screws and wood screws shall be pre-drilled in accordance with AF&PA/NDS. Approved self-drilling screws of equal or greater shear and withdrawal strength shall be permitted without pre-drilling.

(NO CHANGES TO REMAINDER OF ORIGINAL PROPOSAL)

Commenter's Reason:

While the original proposal was approved as submitted, IRC CDC recommended further refinements at Final Action. Every effort has been made to follow-up with the various interests and to respond with improvements to the original proposal, even though approved as submitted. The improvements in this PC are also coordinated with a complimentary PC on FS156-09/10 Part1 (IBC). These refinements are coordinated in this one PC for reasons addressed separately as follows:

Inclusion of Steel Framing

Tables R703.2.1 and R703.2.2 now include siding connections for use with light-frame cold-formed steel siding in addition to light-frame wood as requested at the first hearing. These are needed to provide siding connection solutions applicable to light-frame cold-formed steel construction to ensure coordination with IRC Ch11 and IECC energy code requirements for this type of construction. The Steel Framing Alliance (SFA), American Iron and Steel Institute (AISI), and the Foam Sheathing Coalition (FSC) have worked together toward this end.

The original proposal included connection solutions for attachment of siding over foam sheathing only for wood framing. But, the scope of the original proposal was not otherwise limited to wood framing (i.e., requirements in Table 1405.18.1 of the original proposal are

applicable to both wood and steel framing). The IRC committee approved the original FS156-09/10 proposal, but also expressed concern to “work with industry and bring the needed improvement back to the Final Action.”

Steel framing was not addressed in the original proposal only because test data was not available at that time to justify appropriate solutions. Subsequently, the steel industry together with New York State Research and Energy Development Authority (NYSERDA) has conducted a testing program to provide justification to the solutions proposed in this PC. A report on this testing will be made available at the Final Action hearing and, as soon as available, by request to the proponent (Mark Nowak, SFA, mnowak@steelframing.org). These tests provide the necessary performance data for appropriately designing siding connections to steel framing that span through a thickness of foam sheathing.

These proposed provisions for light-frame cold-formed steel construction are not only coordinated with ICC energy code requirements, but they are necessary to ensure that foam insulation requirements as required by the ICC energy code are implemented in a structurally sound manner. Support of this PC is urged.

Inclusion of Additional Siding Weight Categories:

The original proposal was based on a minimum 11 psf siding dead load (for siding attachment requirements over foam sheathing). While various siding manufacturers supported the original proposal (or remained neutral), several expressed the desire to be included, such as the Masonry Vener Manufacturers Association. Thus, a 25 psf siding weight category and connection requirements have been included in this PC. This also required inclusion of a 3 psf siding weight category such that the lighter weight sidings would not be unduly penalized by basing the table only on heavier siding types.

Simplification, Clarification and Editorial Improvements:

- Content from table footnotes moved into tables for visual clarity and ease of access.
- Removed confusing wind speed requirements from siding attachment table otherwise intending to provide minimum connections for support of siding dead load only and limit foam thickness accordingly. The text is clarified to more explicitly require that the siding attachment be separately designed to resist wind loads.
- Adjusted fastener sizes to be compatible with pneumatic fasteners at request of ISANTA
- Various editorial improvements to language, table headings, etc.

Additional technical justification for siding and furring connections over foam sheathing

The FSC has also funded additional testing of siding over foam sheathing connection assemblies for attachments to wood framing. These tests add further confirmation of the adequacy of the proposed siding attachment requirements for wood framing. It also confirms that siding deflections will be limited to less than 0.015” as commonly used as a design basis for wood connections. A report documenting this testing will also be made available at the final action hearing and will be posted at www.foamsheathing.org as soon as available.

Strengthened QC requirements for foam sheathing wind pressure resistance properties

One of the concerns raised at the first code development hearing on FS156 was related to having assurance that foam sheathing products meet the wind pressure performance requirements upon which the proposal (namely Table R703.3.1) is based. This public comment addresses that concern by clarifying implementation a code-recognized “approved agency” approach that already exists and is commonly used for foam sheathing and other products. The “approved agency” process has shown itself effective and this public comment merely clarifies the application of this process to assure the structural properties (wind pressure resistance) of foam sheathing align with the basis of the proposed end-use requirements and limitations. The minimum performance requirements are based on a representative sample of currently manufactured products of each type as reported by the NAHB Research Center, Inc. (report available at www.foamsheathing.org).

Strengthened Scope Limitations on Foam Sheathing Applications

At the request of the insurance industry, a 110 mph wind speed limit has also been implemented in this proposal for foam sheathing. In addition, wind pressure requirements have been strengthened to require use of negative pressure values in all cases, even when siding is placed over foam sheathing and the siding is separately capable of resisting the full negative design wind pressure.

These provisions are needed for the above reasons, provide improvements for appropriate use of foam sheathing, and provide needed solutions for coordination with the energy code requirements. Again, your approval as modified is urged.