

01 Dec 2016

Test Standard for Determining the Fastener-Sheathing Local Translational Stiffness of Sheathed Cold-Formed Steel Assemblies, 2017 Edition

American Iron and Steel Institute

Follow this and additional works at: <https://scholarsmine.mst.edu/ccfss-aisi-spec>



Part of the [Structural Engineering Commons](#)

Recommended Citation

American Iron and Steel Institute, "Test Standard for Determining the Fastener-Sheathing Local Translational Stiffness of Sheathed Cold-Formed Steel Assemblies, 2017 Edition" (2016). *AISI-Specifications for the Design of Cold-Formed Steel Structural Members*. 199.
<https://scholarsmine.mst.edu/ccfss-aisi-spec/199>

This Technical Report is brought to you for free and open access by Scholars' Mine. It has been accepted for inclusion in AISI-Specifications for the Design of Cold-Formed Steel Structural Members by an authorized administrator of Scholars' Mine. This work is protected by U. S. Copyright Law. Unauthorized use including reproduction for redistribution requires the permission of the copyright holder. For more information, please contact scholarsmine@mst.edu.



AISI S917-17



AISI STANDARD

Test Standard for Determining the Fastener-Sheathing Local Translational Stiffness of Sheathed Cold-Formed Steel Assemblies

2017 Edition



AISI S917-17



AISI STANDARD

Test Standard for Determining the Fastener-Sheathing Local Translational Stiffness of Sheathed Cold-Formed Steel Assemblies

2017 Edition

Approved by
the AISI Committee on Specifications for the Design of
Cold-Formed Steel Structural Members

DISCLAIMER

The material contained herein has been developed by the American Iron and Steel Institute (AISI) Committee on Specifications. The organization and the Committee have made a diligent effort to present accurate, reliable, and useful information on testing of cold-formed steel members, components or structures. The Committee acknowledges and is grateful for the contributions of the numerous researchers, engineers, and others who have contributed to the body of knowledge on the subject. With anticipated improvements in understanding of the behavior of cold-formed steel and the continuing development of new technology, this material will become dated. It is anticipated that future editions of this test procedure will update this material as new information becomes available, but this cannot be guaranteed.

The materials set forth herein are for general information only. They are not a substitute for competent professional advice. Application of this information to a specific project should be reviewed by a registered professional engineer. Indeed, in most jurisdictions, such review is required by law. Anyone making use of the information set forth herein does so at their own risk and assumes any and all resulting liability arising therefrom.

1st Printing – December 2016

Produced by American Iron and Steel Institute

Copyright American Iron and Steel Institute 2016

PREFACE

The American Iron and Steel Institute Committee on Specifications developed this Standard to determine the local translational stiffness ($k_{x\ell}$) supplied by sheathing, fastened to cold-formed steel members.

The Committee acknowledges and is grateful for the contribution of the numerous engineers, researchers, producers and others who have contributed to the body of knowledge on this subject.

User Notes and Commentary are nonmandatory and copyrightable portions of this Standard.

This Page is Intentionally Left Blank.

**AISI Committee on Specifications for the Design
of Cold-Formed Steel Structural Members**

R. L. Brockenbrough, <i>Chairman</i>	R. L. Brockenbrough and Associates
R. B. Haws, <i>Vice-Chairman</i>	Nucor Buildings Group
H. H. Chen, <i>Secretary</i>	American Iron and Steel Institute
D. Allen	Super Stud Building Products
P. Bodwell	Verco Decking
J. Buckholt	Computerized Structural Design
C. J. Carter	American Institute of Steel Construction
J. K. Crews	Unarco Material Handling, Inc.
L. R. Daudet	Simpson Strong-Tie
S. Douglas	National Council of Structural Engineers Association
W. S. Easterling	Virginia Polytechnic Institute and State University
J. M. Fisher	Consultant
S. R. Fox	Canadian Sheet Steel Building Institute
D. Fulton	Triangle Fastener Corporation
R. S. Glauz	RSG Software, Inc.
P. S. Green	Bechtel Power Corporation
W. B. Hall	University of Illinois
G. J. Hancock	University of Sydney
A. J. Harrold	Butler Manufacturing Company
R. A. LaBoube	Wei-Wen Yu Center for Cold-Formed Steel Structures
R. L. Madsen	Supreme Steel Framing System Association
J. A. Mattingly	Consultant
W. McRoy	ICC Evaluation Service, LLC.
J. R. U. Mujagic	Consultant
N. A. Rahman	The Steel Network, Inc.
G. Ralph	ClarkDietrich Building Systems
V. E. Sagan	Metal Building Manufacturers Association
T. Samiappan	OMG, Inc.
A. Sarawit	Simpson Gumpetz & Heger
B. W. Schafer	The Johns Hopkins University
K. Schroeder	Devco Engineering Inc.
R. M. Schuster	Consultant
T. Sputo	Steel Deck Institute
R. Ziemian	Structural Stability Research Council

Subcommittee 6 – Test-Based Design

L. R. Daudet, <i>Chairman</i>	Simpson Strong-Tie
H. H. Chen, <i>Secretary</i>	American Iron and Steel Institute
J. DesLaurier	Certified Steel Stud Association
S. Douglas	National Council of Structural Engineers Association
D. Fox	TOTAL JOIST By ISPAN Systems
S. R. Fox	Canadian Sheet Steel Building Institute
B. Gerber	IAPMO Uniform Evaluation Service
W. Gould	ICC Evaluation Service, LLC.
P. S. Green	Bechtel Power Corporation
W. B. Hall	University of Illinois
J. R. Martin	Verco Decking, Inc.
C. Moen	NBM Technologies, Inc.
T. M. Murray	Consultant
R. V. Nunna	S. B. Barnes Associates
J. Nunnery	Consultant
N. A. Rahman	The Steel Network, Inc.
G. Ralph	ClarkDietrich Building Systems
V. Sagan	Metal Building Manufacturers Association
T. Samiappan	OMG, Inc.
B. W. Schafer	Johns Hopkins University
M. Schmeida	Gypsum Association
R. M. Schuster	Consultant
F. Sesma	California Expanded Metal Products
T. Sputo	Steel Deck Institute

AISI S917-17
TEST STANDARD FOR DETERMINING THE FASTENER-SHEATHING
LOCAL TRANSLATIONAL STIFFNESS OF SHEATHED COLD-FORMED
STEEL ASSEMBLIES

1. Scope

This Standard shall apply for the determination of the local translational stiffness ($k_{x\ell}$) supplied by sheathing, fastened to cold-formed steel members. This Standard consists of sections 1 through 10 inclusive.

Commentary:

This test method can be used for wall studs braced solely by sheathing to experimentally determine the lateral bracing restraint developed at the fastener-sheathing connection. The use of this simple test for determining lateral restraint began with Winter (1960) and an updated treatment and discussion is available in Vieira and Schafer (2012). The test method may be extended to purlins, girts, joists, or any cold-formed steel member in which restraint is provided, in part, by the localized translational stiffness that develops at the connection between a cold-formed steel member and sheathing, such as steel panels, plywood, gypsum board, etc.

References:

Winter, G. (1960), "Lateral Bracing of Beams and Columns," *ASCE Journal of the Structural Division*.

Vieira Jr., L. C. M. and B.W. Schafer (2012), "Lateral Stiffness and Strength of Sheathing Braced Cold-Formed Steel Stud Walls," *Elsevier Engineering Structures*, 37, 205–213.

2. Referenced Documents

The following documents or portions thereof are referenced within this Standard and shall be considered as part of the requirements of this document.

- a. American Iron and Steel Institute (AISI), Washington, DC:
S100-16, *North American Specification for the Design of Cold-Formed Steel Structural Members*
S240-15, *North American Standard for Cold-Formed Steel Structural Framing*
- b. ASTM International (ASTM), West Conshohoken, PA:
A370-14, *Standard Test Methods and Definitions for Mechanical Testing of Steel Products*
E6-09be1, *Standard Terminology Relating to Methods of Mechanical Testing*
IEEE/ASTM SI10-10, *American National Standard for Metric Practice*

3. Terminology

Terms not defined in AISI S100 or AISI S240 shall have the ordinary accepted meaning for the context for which they are intended.

4. Symbols

P_i = Force in an individual fastener at 40% of maximum applied load

- P_u = Maximum applied load
 $P_{0.4}$ = Load at 40% of maximum applied load
 Δ_i = Displacement at an individual fastener at 40% of maximum applied load
 $\Delta_{0.4}$ = Displacement at $0.4P_u$ as measured in test at 40% of maximum applied load
 k_i = Stiffness of individual fastener
 $k_{x\ell}$ = Local translational stiffness of fastener-sheathing system

5. Precision

5.1 Loads shall be recorded to a precision of 1 percent of the maximum load during application of test loads.

5.2 Deflections shall be recorded to a precision of 0.001 in. (0.025 mm).

6. Test Fixture

6.1 The test shall be conducted in a Universal Testing Machine or similar.

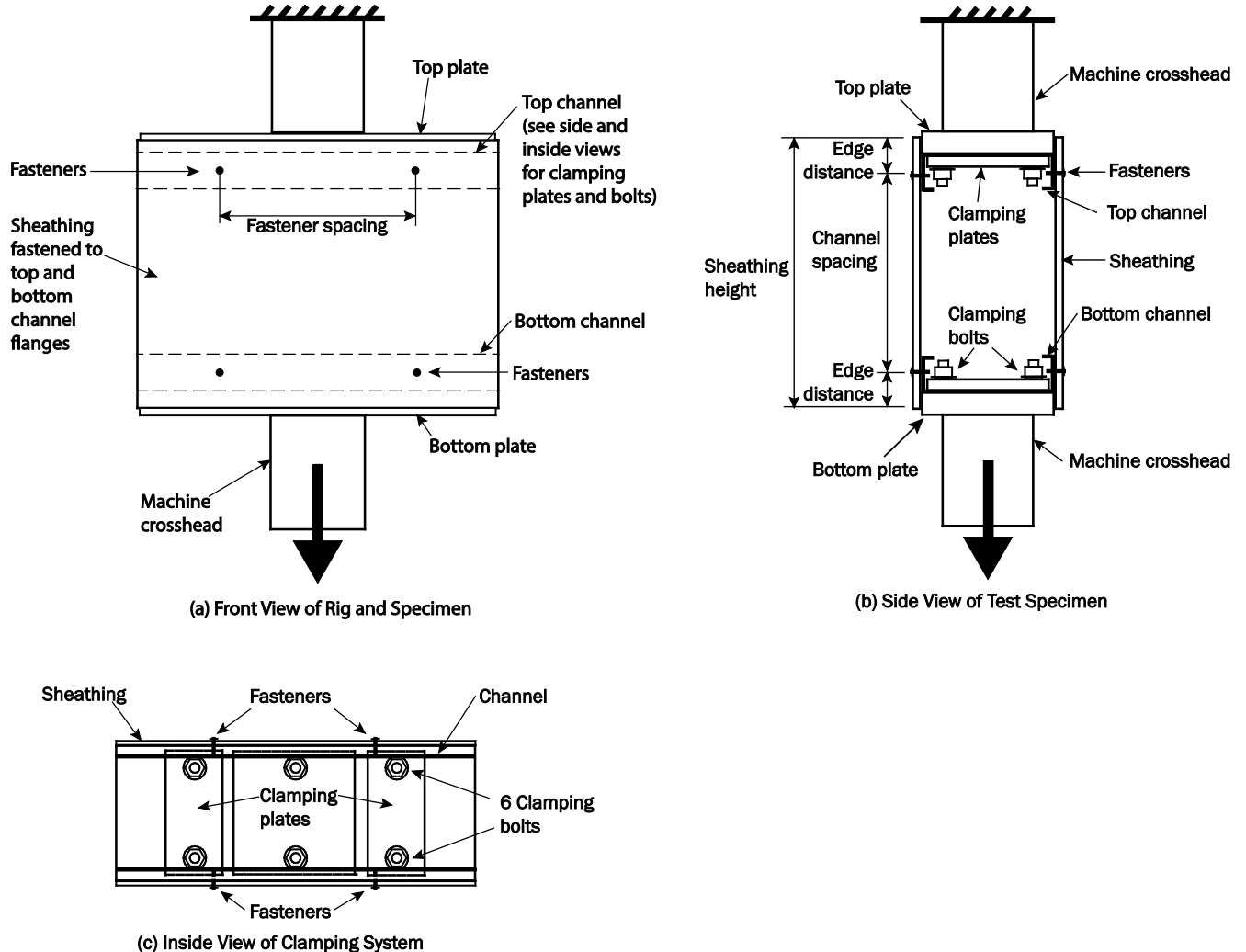

Figure 1 Test Setup

6.2 The test shall consist of two cold-formed steel members connected by sheathing fastened to the flanges (4 fasteners on a side) with webs clamped in fixtures such that the members can be pulled perpendicular to their long axis placing the member-to-sheathing fasteners in shear. See Figure 1 for an example setup applied to lipped channel studs.

6.3 Bending in the web of the member shall be minimized by use of steel clamping plates with a minimum thickness of 5/16 in. (8 mm) or other means.

6.4 Member-to-sheathing fasteners shall be free to tilt.

7. Test Specimen

The test specimen consists of the cold-formed steel members, fasteners, and sheathing.

7.1 The member thickness shall be representative of its intended end use. The member length shall be long enough to accommodate the test fixture including clamping plates, and must be at least equal to the fastener spacing plus required edge distances.

7.2 The fasteners shall be representative of their intended end use. Fastener spacing shall be a minimum of 6 in. (152 mm). Sheathing screws are to be driven to the proper depth appropriate for the head style used: bugle, wafer and flat head screws shall be driven flush with the surface of the sheathing; pan head, round head, and hexwasher head screws shall be driven with the bottom of the head flush with the sheathing. Fasteners are not permitted to have their tips bear against the lip or the web as they tilt. If this condition occurs, shorter fasteners shall be used or the fastener tips ground or cut to length and the test repeated.

7.3 The sheathing shall be representative of its intended end use. The sheathing width should match the member length. The sheathing height shall be 12 in. (305 mm) or the member spacing in its intended end use, whichever is larger, plus the sheathing edge distances. The test results are permitted to be applied for member spacing less than 12 in. (305 mm).

Commentary:

The basic premise of the test specimen is the construction of a small segment of a wall consistent with final application. However, this analogy is incomplete and the test standard recognizes that the primary variables are the cold-formed steel member thickness, the fastener diameter (and local details of the fastener and the fastener head), sheathing thickness, and material properties of the sheathing. Cold-formed steel member dimensions outside of thickness, fastener spacing, and member spacing are not critical variables in this test.

Figure C-1 provides a photograph of an interior view of an example test, which shows a clamping system that could be used in the tests. The photograph also shows that the screws avoid touching the lip or the web during the tests, but this requires creating a gap in the clamping plates to provide this range of motion.



Figure C-1 Photograph of Clamping System

8. Test Procedure

8.1 The test shall be conducted under pseudo-static monotonic load until a maximum (failure) load is reached. A loading rate of 0.02 in./min (0.51 mm/min) shall be applied unless it takes greater than 30 minutes to reach maximum load, in which case a faster load rate may be applied, but not faster than a rate that reaches maximum load in less than 10 minutes.

8.2 The displacement along the applied force shall be measured. Machine displacements (from the internal LVDT that drives the actuator of the Universal Testing Machine) are permitted to be used as the specimen displacement.

9. Data Evaluation

9.1 The local lateral stiffness of the fastener-sheathing system ($k_{x\ell}$) is determined at 40% of the ultimate strength (i.e., maximum applied load or P_u) of the specimen. Specifically:

$$P_{0.4} = 0.4P_u \quad (1)$$

$$P_i = P_{0.4} / 4 \quad (2)$$

$$\Delta_i = \Delta_{0.4} / 2 \quad (3)$$

$$k_{x\ell} = k_i = P_i / \Delta_i \quad (4)$$

where

$P_{0.4}$ = Load at 40% of maximum applied load

P_u = Maximum applied load

$\Delta_{0.4}$ = Displacement at $0.4P_u$ as measured in test at 40% of maximum applied load

P_i = Force in an individual fastener at 40% of maximum applied load

Δ_i = Displacement at an individual fastener at 40% of maximum applied load

k_i = Stiffness of individual fastener

$k_{x\ell}$ = Local translational stiffness of fastener-sheathing system

9.2 The data evaluation shall be consistent with AISI S100, Section K2.1, that is: "Evaluation of the test results shall be made on the basis of the average value of test data resulting from tests of not fewer than three identical specimens, provided the deviation of any individual test result from the average value obtained from all tests does not exceed ± 15 percent. If such deviation from the average value exceeds 15 percent, more tests of the same kind shall be made until the deviation of any individual test result from the average value obtained from all tests does not exceed ± 15 percent, or until at least three additional tests have been made. No test result shall be eliminated unless a rationale for its exclusion can be given." For this criteria, the evaluation of consistency shall be made on the stiffness, $k_{x\ell}$, and the maximum number of tests is permitted to be limited to 6.

Commentary:

Free-body diagrams of the conversion from the specimen to the individual fastener values are provided in Figures C-2 and C-3 below (for illustrative purposes, the specimen subjected to tension is shown in Figures C-2 and C-3). Additional discussion of the determination of the stiffness may be found in Vieira and Schafer (2012).

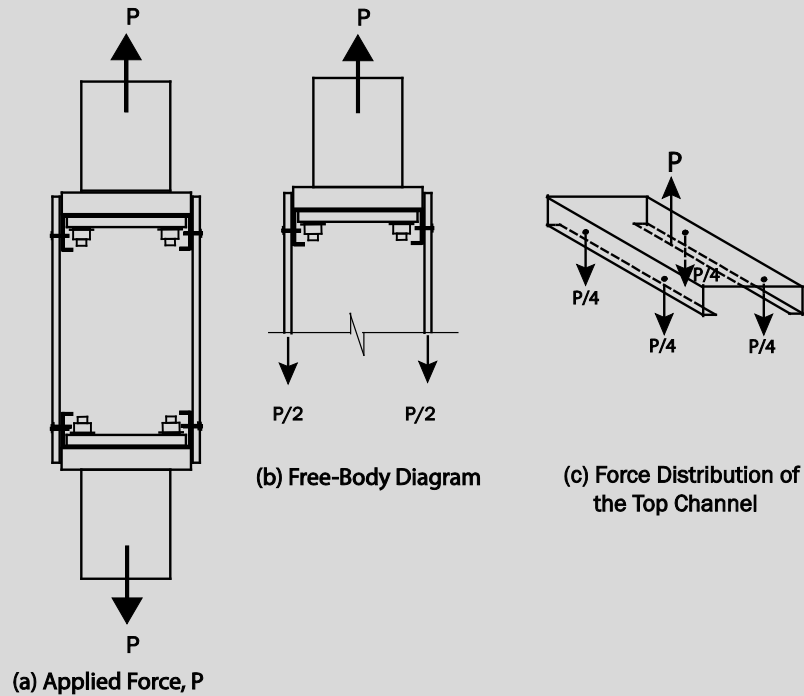

Figure C-2 Free-Body Diagrams for Determination of Individual Fastener Forces, P_i

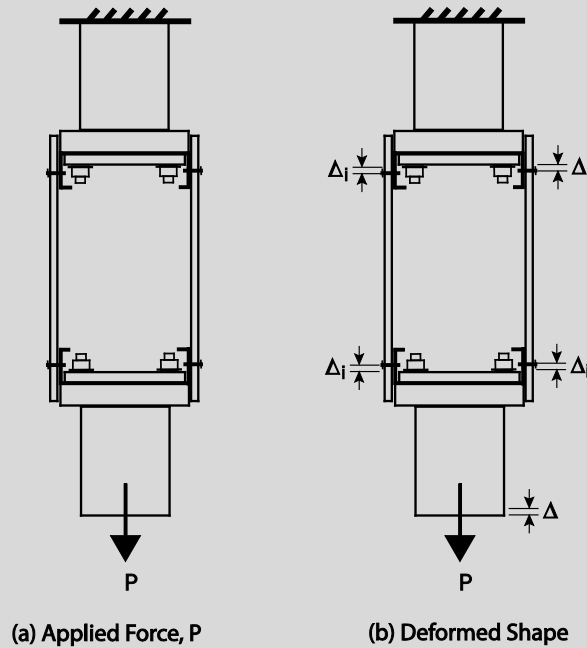

Figure C-3 Free-Body Diagram for Determination of Individual Fastener Stiffness, $k_i = k_{x\ell}$

10. Report

10.1 The test report shall include a description of the tested specimens, including a drawing detailing all pertinent dimensions.

10.2 The test report shall include the measured physical properties consistent with the limitations outlined in Section 7. Conditioning of the sheathing shall be documented.

Commentary:

The major item for documenting the sheathing conditioning is the relative humidity and moisture content, as it can potentially affect the performance of the sheathing material.

10.3 The test report shall include a detailed drawing of the test setup depicting locations and directions of load application, and locations of displacement instrumentation and their point of reference. Additionally, photographs shall supplement the detailed drawings of the test setup.

10.4 The test report shall include load-versus-displacement values and curves, as plotted directly or as reprinted from data acquisition systems.

10.5 The stiffness ($k_{x\ell}$) determined at 40% of the maximum load shall also be drawn on the load vs. displacement curves. Values of $k_{x\ell}$ shall be provided for all tested specimens.

10.6 The test report shall include individual and average maximum test load values observed (i.e., P_u); description of the nature, type and location of failure exhibited by each specimen tested; and a description of the general behavior of the test fixture during load application. Additionally, photographs shall supplement the description of the failure mode(s).

10.7 The test report shall include a description of the test method and loading procedure used, rate of loading, or rate of motion of the crosshead movement.



25 Massachusetts Avenue NW
Suite 800
Washington, DC 20001
www.steel.org





**American
Iron and Steel
Institute**

25 Massachusetts Avenue NW
Suite 800
Washington, DC 20001
www.steel.org

