

01 Oct 2016

North American Standard for the Design of Profiled Steel Diaphragm Panels, 2016 Edition

American Iron and Steel Institute

Follow this and additional works at: <https://scholarsmine.mst.edu/ccfss-aisi-spec>



Part of the [Structural Engineering Commons](#)

Recommended Citation

American Iron and Steel Institute, "North American Standard for the Design of Profiled Steel Diaphragm Panels, 2016 Edition" (2016). *AISI-Specifications for the Design of Cold-Formed Steel Structural Members*. 198.

<https://scholarsmine.mst.edu/ccfss-aisi-spec/198>

This Technical Report is brought to you for free and open access by Scholars' Mine. It has been accepted for inclusion in AISI-Specifications for the Design of Cold-Formed Steel Structural Members by an authorized administrator of Scholars' Mine. This work is protected by U. S. Copyright Law. Unauthorized use including reproduction for redistribution requires the permission of the copyright holder. For more information, please contact scholarsmine@mst.edu.



AISI S310-16



AISI STANDARD

North American Standard for the Design of Profiled Steel Diaphragm Panels

2016 Edition



AISI S310-16



AISI STANDARD

North American Standard for the Design of Profiled Steel Diaphragm Panels

2016 EDITION

DISCLAIMER

The material contained herein has been developed by the American Iron and Steel Institute (AISI) Committee on Specifications. The Committee has made a diligent effort to present accurate, reliable, and useful information on cold-formed steel *diaphragm* design. The Committee acknowledges and is grateful for the contributions of the numerous researchers, engineers, and others who have contributed to the body of knowledge on the subject. Specific references are included in the *Commentary* on the *Standard*.

With anticipated improvements in understanding of the behavior of cold-formed steel *diaphragms* and the continuing development of new technology, this material may eventually become dated. It is anticipated that future editions of this *Standard* will update this material as new information becomes available, but this cannot be guaranteed.

The materials set forth herein are for general information only. They are not a substitute for competent professional advice. Application of this information to a specific project should be reviewed by a registered professional engineer. Indeed, in most jurisdictions, such review is required by law. Anyone making use of the information set forth herein does so at their own risk and assumes any and all resulting liability arising therefrom.

1st Printing – October 2016

2nd Printing – March 2018

Produced by American Iron and Steel Institute

Copyright American Iron and Steel Institute 2016

PREFACE

The American Iron and Steel Institute Committee on Specifications has developed AISI S310-16, the 2016 edition of the *North American Standard for the Design of Profiled Steel Diaphragm Panels*, to provide design provisions for *diaphragms* consisting of profiled steel *decks* or *panels* which include fluted profiles and *cellular deck* profiles. This *Standard* is intended for adoption and use in the United States, Canada and Mexico.

User Notes are non-mandatory portions of this *Standard*.

The major changes of this edition include:

- 1 Incorporating the changes made in AISI S100-16; and
- 2 Revising the *safety* and *resistance factors* in Table B1.1 so that they are consistent with the theory and calibration method presented in AISI S310.

The Committee acknowledges and is grateful for the contributions of the numerous engineers, researchers, producers and others who have contributed to the body of knowledge on the subjects. The Committee particularly acknowledges the pioneering work done by Dr. Larry Luttrell of West Virginia University and Clarkson Pinkham of S. B. Barnes Associates. Special thanks are given to the Chairman of the Diaphragm Design Subcommittee, John Mattingly, and Dr. Helen Chen, Secretary of AISI's Committee on Specifications, for their dedication and commitment. The Committee wishes to also express its appreciation for the support of the *Steel Deck Institute*.

In this second printing, an erratum (amendment on March 1, 2018) is incorporated.

This Page is Intentionally Left Blank.

**AISI COMMITTEE ON SPECIFICATIONS FOR THE DESIGN
OF COLD-FORMED STEEL STRUCTURAL MEMBERS**

R. L. Brockenbrough, <i>Chairman</i>	R. L. Brockenbrough and Associates
R. B. Haws, <i>Vice-Chairman</i>	Nucor Corporation
H. H. Chen, <i>Secretary</i>	American Iron and Steel Institute
D. Allen	Super Stud Building Products
J. Buckholt	Computerized Structural Design
C. J. Carter	American Institute of Steel Construction
J. K. Crews	Unarco Material Handling, Inc.
L. R. Daudet	Simpson Strong-Tie
W. S. Easterling	Virginia Polytechnic Institute and State University
J. M. Fisher	Consultant
S. R. Fox	Canadian Sheet Steel Building Institute
R. S. Glauz	RSG Software, Inc.
P. S. Green	Bechtel Power Corporation
W. B. Hall	University of Illinois
G. J. Hancock	University of Sydney
A. J. Harrold	Butler Manufacturing Company
R. A. LaBoube	Wei-Wen Yu Center for Cold-Formed Steel Structures
R. L. Madsen	Supreme Steel Framing System Association
J. A. Mattingly	Consultant
W. McRoy	ICC Evaluation Service, LLC
J. R. U. Mujagic	Uzun & Case Engineers, LLC
R. Paullus	National Council of Structural Engineers Associations
N. A. Rahman	The Steel Network, Inc.
G. Ralph	ClarkDietrich Building Systems
V. E. Sagan	Metal Building Manufacturers Association
T. Samiappan	OMG, Inc.
A. Sarawit	Simpson Gumpetz & Heger
B. W. Schafer	Johns Hopkins University
K. Schroeder	Devco Engineering Inc.
R. M. Schuster	Consultant
T. Sputo	Steel Deck Institute
R. Ziemian	Structural Stability Research Council

SUBCOMMITTEE 4 – ASSEMBLIES AND SYSTEMS

T. Sputo, <i>Chairman</i>	Steel Deck Institute
H. H. Chen, <i>Secretary</i>	American Iron and Steel Institute
L. R. Daudet	Simpson Strong-Tie
W. S. Easterling	Virginia Polytechnic Institute and State University
D. Fox	TotalJoist By iSPAN Systems
B. Gerber	IAPMO Uniform Evaluation Service
W. Gould	ICC Evaluation Service, LLC
K. Grundahl	SBCA's Cold-Formed Steel Council
W. B. Hall	University of Illinois
J. M. Klaiman	ADTEK Engineers
R. L. Madsen	Supreme Steel Framing System Association
J. R. Martin	Verco Docking, Inc.
J. A. Mattingly	Consultant
B. J. Meyer	W&W Steel
C. Moen	NBM Technologies, Inc.
J. D. Musselwhite	Southern Code Consulting International, LLC
R. V. Nunna	S. B. Barnes Associates
J. N. Nunnery	Consultant
N. A. Rahman	The Steel Network, Inc.
G. Ralph	ClarkDietrich Building Systems
V. E. Sagan	Metal Building Manufacturers Association
H. Salim	University of Missouri-Columbia
B. W. Schafer	Johns Hopkins University
K. Schroeder	Devco Engineering Inc.
W. E. Schultz	Nucor Vulcraft
R. M. Schuster	Consultant
M. Seek	Old Dominion University
K. Voigt	New Millennium Building Systems

SYMBOLS AND DEFINITIONS

Symbol	Definition	Section
A	Number of <i>exterior support connections</i> per flute located at the <i>side-lap</i> at an <i>interior panel</i> or <i>edge panel</i> end	D1, D1.3.1.2
A_a	Material shear deformation component for <i>cellular deck</i>	D5.3.1, D5.3.2
A_e	Ratio of bottom perforated width to the bottom width	Appendix 1.6
A_e	<i>Effective area</i> per unit width of <i>panel</i> at <i>stress</i> , F_n	Appendix 2.3
A_f	Ratio of top perforated width to the top width	Appendix 1.6
A_g	Area of fully effective <i>panel</i> per unit width	Appendices 2.3, 2.4.1
A_i	Ratio of perforated width to the full element width	Appendix 1.6
A_p	Number of <i>interior support connections</i> per flute located at the <i>side-lap</i> at an <i>interior panel</i> or <i>edge panel</i>	D1.1, D1.3.1.2
A_w	Ratio of <i>web</i> perforated width to the <i>web</i> width	Appendix 1.6
A_w	Area per unit width between webs of the bottom <i>panel</i>	D1.7
b	Unit width of <i>diaphragm</i> with concrete fill	D4.2, D4.3
b	Unit length of <i>panel</i>	Appendix 1.4
C	Slip constant considering slippage at <i>side-lap connections</i> and distortion at <i>support connections</i>	D5.1.1, D5.1.2, D5.3.1, D5.3.2, D5.4.1, D5.4.2
C_c	Correlation coefficient	E2.2
C_p	Correction factor	E1.2.2
C_ϕ	Calibration coefficient	E1.2.2
D	Weighted average D_i value for warping across the <i>panel</i> width, w	Appendix 1.4
D_d	Depth of <i>panel</i>	D1
D_n	Warping factor considering distortion at <i>panel</i> ends	D5.1.1, D5.1.2, Appendices 1.1, 1.4, 1.5
D_{ni}	Warping factor for each corrugation	Appendix 1.5
D_1	Value for warping where bottom flange fastener is in every valley	Appendix 1.4
D_2	Value for warping where bottom flange fastener is in every second valley	Appendix 1.4
D_3	Value for warping where bottom flange fastener is in every third valley	Appendix 1.4
D_4	Value for warping where bottom flange fastener is in every fourth valley	Appendix 1.4
d	Visible diameter of outer surface of arc spot weld	D1.1.1, D1.2.1, E1.2.1, E2.1.1, E2.4.1
d	Width of arc seam weld	D1.1.1
d	Nominal diameter of fastener	D1.1.2, D1.1.4.2, D1.1.4.3, D3.1.2.2, D3.1.4

SYMBOLS AND DEFINITIONS

Symbol	Definition	Section
d	<i>Panel corrugation pitch</i>	D2.1, D2.2, D5.1.1, D5.4.1, D5.4.2
d	<i>Panel corrugation pitch of top fluted deck</i>	D2.2, D5.3.1, D5.3.2
d_a	Average diameter of arc spot weld at mid-thickness of t	D1.1.1, D1.2.1
d_a	Average width of seam weld	D1.1.1
d_c	Concrete thickness above top of <i>deck</i>	D4.2, D4.3, D5.4.1, D5.4.2, E2.1.2, E2.4, E2.4.1, E2.4.2
$d_{c \text{ test}}$	Average tested concrete thickness above top of <i>deck</i> measured at supports	E2.1.2, E2.4, E2.4.1, E2.4.2
d_e	Effective diameter of fused area at plane of maximum shear transfer	D1.1.1, D1.5.2
d_o	Hole diameter in washer	D1.1.1
$d_{s \text{ test}}$	Average measured equivalent visible diameter of arc spot weld at <i>side-laps</i>	E1.2.1
d_{test}	Average measured visible diameter of arc spot weld at supports	E1.2.1
d_{test}	Average measured visible diameter of the smallest set of 10 arc spot welds	E2.1.1, E2.4.1
d'	Equivalent width of <i>cellular deck</i> bottom plate adjusted for perforations and measured between longitudinal rows of fasteners connecting the top <i>deck</i> to the bottom plate	D5.3.2
E	Modulus of elasticity of steel	D1.1.1, D5.1.1, D5.3.1, D5.4.1, D5.4.2, Appendices 1.4, 2.3
E_p	Width of perforation band in bottom flat of width $2e$	D5.1.2, D5.3.2
e	One-half the bottom flat width of <i>panel</i> measured between points of intercept	D2.1, Appendix 1.6
e	Distance from the cell top <i>deck</i> longitudinal fastener to the <i>web</i> , in. (mm)	D5.3.1
e	Distance from the end of the material to the tangent point at the outer edge of the weld, fastener, or hole	D1.1.6
e_{min}	Clear distance between end of material and weld, fastener, or hole to develop full connection strength	D1.1.6
e'_{min}	Clear distance between end of material and weld, fastener, or hole to develop required <i>connection</i> strength	D1.1.6
e_p	One-half the modified bottom width of <i>acoustic panel</i>	D2.1, Appendix 1.6
F	<i>Diaphragm flexibility</i>	C3, D6
F_e	Elastic flexural <i>buckling stress</i> of <i>panel</i>	Appendix 2.3

SYMBOLS AND DEFINITIONS

Symbol	Definition	Section
F_m	Mean value of fabrication factor	E1.2.2
F_n	Compressive stress at the nominal axial strength [resistance]	Appendix 2.3
F_p	Width of perforation band in top flat of width, f	D5.1.2, D5.3.2
F_u	Tensile strength of sheet as determined in accordance with AISI S100 Sections A3.1, or A3.2	D, D1.1, D1.1.1, D1.1.6, D1.2.1, D1.2.2, D1.2.3, D1.2.4, D4, E2.4, E2.4.1
$F_{u \text{ deck}}$	Tensile strength of deck or panel	E1.2.1
$F_{u \text{ support}}$	Tensile strength of support	E1.2.1
$F_{u \text{ test}}$	Average tested value of panel's tensile strength for an individual test, i	E2.4, E2.4.1
$F_{u \text{ washer}}$	Tensile strength of washer	D1.1.1
F_{u1}	Tensile strength of member in contact with screw or nail head or washer	D1.1.2, D1.1.4.2
F_{u2}	Tensile strength of member not in contact with screw head or washer	D1.1.2
F_v	Nominal shear stress [resistance]	D1.7
F_{xx}	Tensile strength of electrode classification	D1.1.1, D1.2.1, D1.2.4
F_y	Specified yield stress of steel	D, D1.1, D1.2.4, D4, Appendices 2.3, 2.4.1
$F_{y \text{ deck}}$	Yield stress of deck or panel	E1.2.1
f	Top flat width of panel measured between points of intercept	D2.1, D5.3.1, Appendix 1.5
f_p	Modified top flat width of acoustic panel	D2.1, Appendix 1.5
f'_c	Concrete compressive strength	D4, D4.2, D4.3, D5.4.1, D5.4.2, E2.1.2, E2.4, E2.4.1, E2.4.2
$f'_{c \text{ test}}$	Average tested concrete compressive strength for an individual test, i	E2.1.2, E2.4, E2.4.1, E2.4.2
G	Specific gravity of wood	D1.1.4.2, D3.1.2.2, D3.1.4
G'	Diaphragm stiffness	C3, D1.6, D5.1.1, D5.1.2, D5.3.1, D5.3.2, D5.4.1, D5.4.2, D6, E1.2.1, E1.2.2, Appendix 1.1
G'	Diaphragm stiffness used in design	E2.1
$G'_{i \text{ test}}$	Tested diaphragm stiffness for an individual test, i	E1.2.2, E2.1
$G'_{i \text{ theory}}$	Theoretical diaphragm stiffness for an individual test, i	E1.2.2
h_s	Threaded length of screw, including the tapered tip that is penetrated into wood support	D1.1.4.2, D1.1.4.3, D3.1.2.2

SYMBOLS AND DEFINITIONS

Symbol	Definition	Section
h_{sf}	Nail penetration into wood support required to develop full strength	D1.1.4.2, D1.1.4.3, D3.1.4
h_{sn}	Length of nail that is penetrated into wood support	D1.1.4.2, D1.1.4.3, D3.1.4
h_{st}	Nominal seam height measured to the top of the seam prior to welding	D1.2.4
I_{xg}	Moment of inertia of fully effective <i>panel</i> per unit width	D2.1, D2.2, Appendix 2.3
i	Index of tests	E1.2.2
K	Stiffness factor relating support and <i>side-lap connection flexibilities</i>	D5.1.1
K	Effective length factor	Appendix 2.3
K_{E_i}	Indicator of relative flexural stiffness of an element without perforations to the stiffness of the element with perforations over part of its length, ($i = e, f, w$)	Appendix 1.6
K_{ij}	Spring constant at joint, i , on a <i>panel</i> associated with a bottom flat connection spacing or released restraint, j , on the <i>panel</i>	Appendix 1.4
K_3	Stiffness contribution of concrete fill	D5.4.1, D5.4.2
k	Factor for <i>structural concrete</i> strength	D4.2
k	Ratio of perforated element stiffness to that of a solid element of the same thickness	D5.1.2, D5.3.2, Appendix 1.6
k_b	Ratio of shear stiffness of perforated zone in the bottom plate of <i>cellular deck</i> to a solid zone of the same thickness, t_b	D5.3.2
L	Total <i>panel</i> length	D1, D1.3.1.1, D1.4, D4.2, D4.4, D5.1.1, E2.5, Appendices 1.4, 2.2
L	Length of seam weld, not including circular ends	D1.1.1
L_d	<i>Diaphragm</i> span measured between <i>lateral force-resisting systems</i>	D1
L_v	Span of <i>panel</i> between supports with fasteners	D1, D2.1, D4.4, E2.5, Appendix 2.3
L_w	Length of fillet, groove, or <i>top arc seam side-lap weld</i>	D1.2.2, D1.2.3, D1.2.4, E1.2.1, D5.2.1.2, E2.1.1
$L_{w \text{ test}}$	Average fused length for the largest set of 10 <i>top arc seam side-lap welds</i>	E2.1.1
M_m	Mean value of material factor	E1.2.2
M_n	Nominal flexural strength [resistance] of <i>deck</i> or <i>panel</i>	Appendix 2.3.1

SYMBOLS AND DEFINITIONS

Symbol	Definition	Section
M_x	per unit width Required flexural strength per unit width in ASD	Appendices 2.3.1, 2.4.1
\overline{M}_x	Required flexural strength [moment due to factored loads] per unit width in LRFD and LSD	Appendices 2.3.1, 2.4.1
N	Number of support connections per unit width at an interior or edge panel's end	D1, D4.4, Appendix 2.2
n	Total number of tests	E1.2.2, E2.1, E2.2
n	Number of corrugations in a total panel cover width	Appendix 1.5
n_e	Number of edge support connections between transverse supports and along an edge panel length	D1
n_e	Number of edge support connections equally distributed along an edge panel length with concrete fill	D4.4
n_p	Number of interior supports along a total panel length	D1, D5.1.1, E2.5
n_s	Number of side-lap connections along a total panel length and not into supports	D1, D1.3.1.1, D1.3.1.2, D5.1.1
P	Required compressive axial strength per unit width for ASD	Appendix 2.3.1
\overline{P}	Required compressive axial strength [force due to factored loads] per unit width for LRFD and LSD	Appendix 2.3.1
P_m	Mean value of professional factor for tested component	E1.2.2, E2.2
P_n	Nominal compressive axial strength [resistance] of panel per unit width	Appendix 2.3
P_{nf}	Nominal shear strength [resistance] of a support connection per fastener	D1, D1.1, D1.1.1, D1.1.2, D1.1.3, D1.1.5, D1.3, D1.3.1.2, D1.3.2, D1.3.3, D1.4, D1.5.2, D3.1, D3.1.1, D3.1.2.1, D3.1.2.2, D3.1.3, D3.1.4, D4.2, D4.4, E1.2, E1.2.1, Appendix 2.2
P_{nf}	Nominal shear strength [resistance] of connection limited by bearing of screw or nail against wood support or panel, and modified in accordance with penetration	D1.1.4.2, D1.1.4.3
P_{nf}'	Nominal shear strength [resistance] of connection through top flat of panel and at a side-lap	D1.1.4.3
P_{nfs}	Nominal shear strength [resistance] of an edge support connection installed parallel with an edge panel span and between transverse supports	D1, D1.1, D1.1.1, D1.1.2, D1.1.3, D1.1.4.2, D1.1.5, D1.3, D3.1, E1.2, E1.2.1
P_{nfs}	Nominal shear strength [resistance] of an edge support connection installed parallel with an edge panel span with	D4.4

SYMBOLS AND DEFINITIONS

Symbol	Definition	Section
	concrete fill	
P_{nft}	Nominal shear strength [resistance] of a support connection per fastener in presence of tensile load	D3.1, D3.1.1, D3.1.2.1, D3.1.2.2, D3.1.3, D3.1.4
P_{nfw}	Nominal shear strength [resistance] of a fully penetrated wood support connection controlled by bearing against wood	D1.1.4.2, D3.1.2.2, D3.1.4
P_{nfwS}	Nominal shear strength [resistance] of wood support connection for fully penetrated screw or nail and controlled by bearing against panel	D1.1.4
P_{not}	Nominal tensile strength [resistance] of a support connection per fastener controlled by pull-out	D3.1.2.1, D3.1.3
P_{nov}	Nominal tensile strength [resistance] of a support connection per fastener controlled by pull-over	D3.1.2.1, D3.1.3
P_{npa}	Nominal shear breaking strength [resistance] of power-actuated fastener	D1.1.3
P_{ns}	Nominal shear strength [resistance] of a side-lap connection per fastener	D1, D1.1.2, D1.1.4.3, D1.2, D1.2.1, D1.2.2, D1.2.3, D1.2.4, D1.2.5, D1.2.6, D1.2.7, D1.3.1.1, D1.3.1.2, D1.3.2, D1.4, D1.5.2, D3.2, D5.1.1, E1.2, E1.2.1
P_{nss}	Nominal shear breaking strength [resistance] of screw or nail	D1.1.2, D1.1.4.2, D1.1.4.3, D3.1.2.1
P_{nt}	Nominal tension strength [resistance] of a support connection per fastener	D3.1.1
P_{nts}	Nominal tensile breaking strength [resistance] of screw or nail	D3.1.2.1
P_{nT}	Nominal pull-out strength [resistance] of wood support connection per fastener	D3.1.2, D3.1.4
P'_{nf}	Nominal shear strength [resistance] of a fully penetrated wood support connection through panel top flat	D1.1.4.3
P'_{nfw}	Nominal shear strength [resistance] of a support connection per fastener controlled by bearing against wood and modified for wood penetration	D3.1.2.2, D3.1.4
p_o	Ratio of the area of perforations to the total area in the perforated band	Appendix 1.6
R	Required strength for ASD	C2, D1.1.6, D4.4
R_f	Effect of factored loads for LSD	C2, D1.1.6, D4.4
$R_{n,i}$	Calculated connection strength of Test i per rational engineering analysis	E1.2.2(b)

SYMBOLS AND DEFINITIONS

Symbol	Definition	Section
$R_{n,i}$	Calculated <i>nominal diaphragm shear strength [resistance]</i> per unit length, $S_{ni \text{ theory}}$, of Test i per <i>diaphragm</i> system model	E1.2.2(c)
$R_{t,i}$	Tested <i>connection</i> strength of Test i	E1.2.2(b)
$R_{t,i}$	Tested <i>nominal diaphragm shear strength [resistance]</i> per unit length, $S_{ni \text{ test}}$, of Test i	E1.2.2(c)
R_u	<i>Required strength</i> for LRFD	C2, D1.1.6, D4.4
r	Radius of gyration of <i>panel</i>	Appendix 2.3
S_f	Structural support <i>connection flexibility</i>	D5.1.1, D5.1.2, D5.2, D5.2.1.1, D5.2.2, D5.2.3, D5.3.1, D5.3.2, E1.2, E1.2.1
S_n	<i>Nominal shear strength [resistance]</i> per unit length of <i>diaphragm</i> system	C2, D, D1.4, D1.5, D1.6, D1.7, D4.2, D4.4, D5.1.1, E1.2.1, E1.2.2
S_n	<i>Nominal shear strength [resistance]</i> per unit length used in design and the <i>average adjusted shear strength [resistance]</i> per unit length of all n tests	E2.1, E2.2, E2.4
S_{nb}	<i>Nominal shear strength [resistance]</i> per unit length of <i>diaphragm</i> system controlled by out-of-plane <i>buckling</i>	D, D2.1, E1.2.1
S_{nc}	<i>Nominal shear strength [resistance]</i> per unit length of <i>diaphragm</i> or <i>wall diaphragm</i> controlled by <i>support connections</i> at the corners of <i>interior</i> or <i>edge panels</i>	D1, D1.3, D3.1
S_{ne}	<i>Nominal shear strength [resistance]</i> per unit length of <i>diaphragm</i> or <i>wall diaphragm</i> controlled by <i>connections</i> along the edge parallel to the <i>panel</i> span in an <i>edge panel</i> and located at a <i>diaphragm</i> reaction line	D1, D1.1, D1.3, D3.1
S_{nf}	<i>Nominal shear strength [resistance]</i> per unit length of <i>diaphragm</i> system controlled by <i>connections</i>	D, D1, D1.3, D1.3.1.1, D1.3.1.2, D1.3.2, D1.3.3, E2.2, Appendix 2.2
S_{ni}	<i>Nominal shear strength [resistance]</i> per unit length of <i>diaphragm</i> or <i>wall diaphragm</i> controlled by <i>connections</i> at <i>interior</i> or <i>edge panels</i>	D1, D1.1, D1.3, D3.1
$S_{ni \text{ adj test}}$	<i>Adjusted shear strength [resistance]</i> per unit length for an individual test, i	E2.1, E2.4, E2.4.1
$S_{ni \text{ test}}$	Tested <i>shear strength [resistance]</i> per unit length for an individual test, i	E2.4, E2.4.1, E2.4.2
$S_{n \text{ theory}}$	Calculated <i>diaphragm shear strength [resistance]</i> per unit length for a <i>configuration</i> based on specified parameters	E2.2
$S_{ni \text{ theory}}$	Calculated <i>diaphragm shear strength [resistance]</i> per unit length for test, i	E1.2, E1.2.1, E1.2.2

SYMBOLS AND DEFINITIONS

Symbol	Definition	Section
S_{nx}, S_{ny}	Shear flow along orthogonal axes x and y , respectively	D1
S_{nw}	Nominal shear strength [resistance] per unit length of bottom panel acting as web	D1.7
S_{req}	Required diaphragm shear strength [force due to factored loads] per unit length	D3.1.2.2
S_s	Side-lap connection flexibility	D5.1.1, D5.1.2, D5.2, D5.2.1.1, D5.2.1.2, D5.2.2, D5.2.5, D5.3.1, D5.3.2, E1.2, E1.2.1
s	Developed flute width per pitch	D2.1, D5.1.1, D5.4.1, D5.4.2, Appendix 1.4
s	Developed flute width per pitch modified for perforations	D5.1.2
s	Developed flute width per pitch of top deck in cellular deck	D2.2, D5.3.1, D5.3.2, D5.4.1
s	Minimum center-to-center spacing of top arc seam side-lap welds	D1.2.4
s'	Developed flute width of top deck per width, w_d , in cellular deck modified for perforation	D5.3.2
T	Required allowable tensile strength of a support connection per fastener	D3.1.1, D3.1.2.1, D3.1.3, D3.1.4
T	Required tensile axial strength per unit width for ASD	Appendix 2.2-2
\bar{T}	Required tensile strength [tensile force due to factored loads] of a support connection per fastener	D3.1.1, D3.1.2.1, D3.1.3, D3.1.4
\bar{T}	Required tensile axial strength [tensile force due to factored loads] per unit width for LRFD and LSD	Appendix 2.4.1
T_f	Effect of factored tensile load on a support connection per fastener for LSD	D3.1.1, D3.1.2.1, D3.1.3, D3.1.4
T_n	Nominal tensile axial strength [resistance] of panel per unit width	Appendix 2.4.1
T_u	Required tensile strength of a support connection per fastener for LRFD	D3.1.1, D3.1.2.1, D3.1.3, D3.1.4
t	Base steel thickness of panel	D1, D2.1, D5.1.1, D5.4.1, D5.4.2, E2.4, E2.4.1
t	Total combined base steel thickness of panel involved in shear transfer above the shear transfer plane	D1.1.1, D1.2.1, D5.2.1.1, D5.2.1.2, D5.2.2, D5.2.3, D5.2.5
t	Total combined base steel thickness of sheets beneath the washer and above the shear transfer plane	D1.1
t	Base steel thickness of thinner element at side-lap weld	D1.2.2, D1.2.3, D1.2.4
t	Base steel thickness of top deck in cellular deck	D2.2, D5.3.1, D5.3.2, D5.4.1,

SYMBOLS AND DEFINITIONS

Symbol	Definition	Section
		D5.4.2
t_b	Base steel <i>thickness</i> of bottom element in <i>cellular deck</i>	D5.3.1, D5.3.2
t_{deck}	<i>Thickness</i> of deck or panel	E1.2.1
$t_{support}$	<i>Thickness</i> of support	E1.2.1, E2.4.1
t_{test}	Average tested value of <i>panel's thickness</i> for an individual test, i	E2.4, E2.4.1
t_1	Thickness of member in contact with screw or nail head or washer	D1.1.2, D1.1.4.2
t_1	Design <i>thickness</i> of thinner element of <i>panel</i> at the <i>side-lap</i>	D1.1.4.3
t_2	<i>Thickness</i> of member not in contact with screw head or washer	D1.1.2
U_1	Number of corrugations having fasteners in every valley across the <i>panel</i> width, w	Appendix 1.4
U_2	Number of corrugations having fasteners in every second valley across the <i>panel</i> width, w	Appendix 1.4
U_3	Number of corrugations having fasteners in every third valley across the <i>panel</i> width, w	Appendix 1.4
U_4	Number of corrugations having fasteners in every fourth valley across the <i>panel</i> width, w	Appendix 1.4
V	<i>Required allowable shear strength</i> of a support connection per fastener	D3.1.2.2
\bar{V}	<i>Required shear strength</i> [effect due to factored loads] of a support connection per fastener	D3.1.2.2
V_f	Effect of <i>factored shear load</i> on a support connection per fastener for <i>LSD</i>	D3.1.2.2
V_u	<i>Required shear strength</i> of a support connection per fastener for <i>LFRD</i>	D3.1.2.2
V_F	Coefficient of variation of fabrication factor	E1.2.2
V_M	Coefficient of variation of material factor	E1.2.2
V_Q	Coefficient of variation of load effect	E1.2.2
V_P	Coefficient of variation of test results	E1.2.2, E2.2
W_p	Width of perforation band in the <i>web</i> flat of width, w	D5.1.2, D5.3.2
w	<i>Panel cover</i> width	D1, D5.1.1
w	Web flat width of <i>panel</i> measured at points of intercept	D2.1, D5.3.1, Appendix 1.6
w	Concrete density	D4.2
w_a	External nominal load reaction requiring <i>allowable</i>	Appendix 2.2

SYMBOLS AND DEFINITIONS

Symbol	Definition	Section
	<i>diaphragm strength, S_{nf} / Ω_{df}</i>	
w_d	Distance between longitudinal rows of fasteners connecting the top <i>deck</i> to the bottom plate	D5.3.1, D5.3.2
w_{dp}	Total width of perforation bands in bottom plate width, w_d	D5.3.2
w_e	<i>Panel cover width at an edge panel</i>	D1
w_p	Modified web flat width of <i>acoustic panel</i>	D2.1, Appendix 1.6
w_u	Factored external nominal load reaction demanding the <i>design diaphragm strength [factored resistance]</i> , $\phi_{df} S_{nf}$	Appendix 2.2
x_e	Distance from <i>panel centerline</i> to an <i>exterior support structural connection</i> in a <i>panel</i>	D1
x_{ee}	Distance from <i>panel centerline</i> to an <i>exterior support structural connection</i> in an <i>edge panel</i>	D1
x_p	Distance from <i>panel centerline</i> to an <i>interior support structural connection</i> in a <i>panel</i>	D1
x_{pe}	Distance from <i>panel centerline</i> to an <i>interior support structural connection</i> in an <i>edge panel</i>	D1
α	Conversion factor for units	D2.1, D3.1.2.2, D3.1.4, D4.4, D5.2.1.1, D5.2.1.2, D5.2.2, D5.2.3, D5.2.5, Appendix 1.5
α_1	Measure of <i>exterior support fastener group</i> distribution across <i>panel width</i> at an <i>edge panel</i>	D1
α_2	Measure of <i>interior support fastener group</i> distribution across <i>panel width</i> at an <i>edge panel</i>	D1
α_3	Measure of <i>exterior support fastener group</i> distribution across <i>panel width</i> at an <i>interior panel</i>	D5.1.1
α_4	Measure of <i>interior support fastener group</i> distribution across <i>panel width</i> at an <i>interior panel</i>	D5.1.1
α_5	Conversion factor for units	D5.2.1.2
α_s	Ratio of <i>diaphragm side-lap connection strength</i> to <i>support connection strength</i>	D1, D1.3.1.2, D1.3.2
α_e^2	Analogous section modulus of <i>panel exterior support connection group</i> in an <i>interior or edge panel</i>	D1, E2.5
α_p^2	Analogous section modulus of <i>panel interior support connection group</i> in an <i>interior or edge panel</i>	D1, E2.5
β	Factor defining <i>connection interaction contribution</i> to <i>diaphragm shear strength per unit length</i>	D1, D1.3.1.2, D4.2, E2.5, Appendix 2.2

SYMBOLS AND DEFINITIONS

Symbol	Definition	Section
β_o	Target reliability index	E1.2.2
γ_c	Support factor for warping	D5.1.1, Appendix 1.3
γ_i	Final displacement indicator at top of corrugation for valley fastener cases, $i = 1$ to 4	Appendix 1.4
Δ_{ij}	Deflection at joint, i , on a <i>panel</i> caused by a unit load per unit length at joint, j , on the <i>panel</i>	Appendix 1.4
δ_a	Allowable <i>diaphragm</i> deflection defined by the applicable building code and the structure's service requirements	C3
δ_n	Theoretical <i>diaphragm</i> deflection at service load or nominal loads [specified loads]	C3
δ_{bi}	Lateral displacement indicator at bottom of corrugation for valley fastener cases, $i = 1$ to 4	Appendix 1.4
δ_{ti}	Lateral displacement indicator at top of corrugation for valley fastener cases, $i = 1$ to 4	Appendix 1.4
δ_{ij}	Deflection indicator of profile racking per unit load per unit length required for D	Appendix 1.4
κ_{ij}	Spring constant indicator required for D	Appendix 1.4
λ	Connection strength reduction factor at corner fastener	D1, D1.7
λ_c	Slenderness factor	Appendix 2.3
μ	Poisson's ratio for steel	D5.1.1, D5.4.1, D5.4.2
ϕ	<i>Resistance factor</i> for <i>diaphragm</i> strength	C2, D, D1, D1.1.4.1, D1.7, D3.1.2.2, D4.1, E1.2.2, E2.2
ϕ	<i>Resistance factor</i> for a screw connection subjected to combined shear and pull-over or pull-out interaction	D3.1.2.1
ϕ	<i>Resistance factor</i> for nail connection for pull-out	D3.1.4
ϕ_b	<i>Resistance factor</i> for <i>panel</i> in flexure	Appendix 2.3.1, 2.4.1
ϕ_c	<i>Resistance factor</i> for <i>panel</i> in axial compression	Appendix 2.2.1
ϕ_d	<i>Resistance factor</i> for <i>diaphragm</i> controlled by connections	B1, D3.1.2.1, D4.4
ϕ_{db}	<i>Resistance factor</i> for <i>diaphragm</i> strength controlled by out-of-plane buckling	D, E1.2.1, E2.2
ϕ_{df}	<i>Resistance factor</i> for <i>diaphragm</i> strength controlled by connections	D, E2.2, Appendix 2.2
ϕ_t	<i>Resistance factor</i> for connection subject to tension	D3.1.1, D3.1.2.1
ϕ_{tot}	<i>Resistance factor</i> for power-actuated fastener controlled	D3.1.3

SYMBOLS AND DEFINITIONS

Symbol	Definition	Section
	by pull-out	
ϕ_{tov}	Resistance factor for power-actuated fastener controlled by pull-over	D3.1.3
ϕ_v	Resistance factor for bottom panel acting as web	D1.7
ψ	Number of corrugations between support fasteners at the panel end for the set of corrugations containing the corrugation, i	Appendix 1.5
Ω	Safety factor for diaphragm strength	C2, D, D1, D1.1.4.1, D1.7, D3.1.2.2, D4.1, E1.2.2, E2.2
Ω	Safety factor for a screw connection subjected to combined shear and pull-over or pull-out interaction	D3.1.2.1
Ω	Safety factor for nail connection for pull-out	D3.1.4
Ω_b	Safety factor for panel in flexure	Appendices 2.3.1, 2.4.1
Ω_c	Safety factor for panel in axial compression	Appendix 2.3.1
Ω_d	Safety factor for diaphragm strength controlled by connections	B1, D3.1.2.1, D4.4
Ω_{db}	Safety factor for diaphragm strength controlled by panel out-of-plane buckling	D, E1.2.1, E2.2
Ω_{df}	Safety factor for diaphragm strength controlled by connections	D, E2.2, Appendix 2.2
Ω_t	Safety factor for connection subject to tension	D3.1.1, D3.1.2.1
Ω_t	Safety factor for panel in axial tension	Appendix 2.4.1
Ω_{tot}	Safety factor for power-actuated fastener controlled by pull-out	D3.1.3
Ω_{tov}	Safety factor for power-actuated fastener controlled by pull-over	D3.1.3
Ω_v	Safety factor for bottom panel acting as web	D1.7

TABLE OF CONTENTS

NORTH AMERICAN STANDARD FOR THE DESIGN OF PROFILED STEEL DIAPHRAGM PANELS

Disclaimer	ii
Preface	iii
Symbols and Definitions	vii
List of Tables	xxiii
List of Figures	xxiv
NORTH AMERICAN STANDARD FOR THE DESIGN OF PROFILED STEEL DIAPHRAGM PANELS	1
A. GENERAL PROVISIONS	1
A1 Scope, Applicability, and Definitions	1
A1.1 Scope	1
A1.2 Applicability	1
A1.3 Definitions	2
A2 Materials	4
A3 Loads	4
A4 Referenced Documents	4
A5 Units of Symbols and Terms	5
B. SAFETY FACTORS AND RESISTANCE FACTORS	6
B1 Safety Factors and Resistance Factors of Diaphragms With Steel Supports and No Concrete Fill	6
B1.1 Floor, Roof, or Wall Steel Diaphragm Construction	6
C. DIAPHRAGM AND WALL DIAPHRAGM DESIGN	8
C1 General	8
C2 Strength Design	8
C3 Deflection Requirements	8
D. DIAPHRAGM NOMINAL SHEAR STRENGTH PER UNIT LENGTH AND STIFFNESS DETERMINED BY CALCULATION	10
D1 Diaphragm Shear Strength per Unit Length Controlled by Connection Strength, S_{nf}	11
D1.1 Support Connection Shear Strength in Fluted Deck or Panels, P_{nf} and P_{nfs}	15
D1.1.1 Arc Spot Welds or Arc Seam Welds on Steel Supports	15
AISI S100 J2.2.1 Minimum Edge and End Distance	15
AISI S100 J2.2.2.1 Shear Strength [Resistance] for Sheet(s) Welded to a Thicker Supporting Member	16
AISI S100 J2.3.1 Minimum Edge and End Distance	18
AISI S100 J2.3.2.1 Shear Strength [Resistance] for Sheet(s) Welded to a Thicker Supporting Member	18
D1.1.2 Screws Into Steel Supports	19
AISI S100 J4.3.1 Shear Strength [Resistance] Limited by Tilting and Bearing	20
D1.1.3 Power-Actuated Fasteners Into Steel Supports	20
D1.1.4 Fasteners Into Wood Supports	21
D1.1.4.1 Safety Factors and Resistance Factors	21
D1.1.4.2 Screw or Nail Connection Strength Through Bottom Flat and Into Support	21
D1.1.4.3 Screw or Nail Connection Strength Through Top Flat and Into Support	23
D1.1.5 Other Connections With Fasteners Into Steel, Wood or Concrete Support	25

D1.1.6	Support Connection Strength Controlled by Edge Dimension and Rupture.....	26
D1.2	Side-Lap Connection Shear Strength [Resistance] in Fluted Deck or Panel, P_{ns}	26
D1.2.1	Arc Spot Welds.....	27
AISI S100 J2.2.2.2	Shear Strength [Resistance] for Sheet-to-Sheet Connections	27
D1.2.2	Fillet Welds Subject to Longitudinal Shear	28
D1.2.3	Flare Groove Welds Subject to Longitudinal Shear	28
D1.2.4	Top Arc Seam Side-Lap Welds Subject to Longitudinal Shear	29
D1.2.5	Side-Lap Screw Connections.....	30
D1.2.6	Non-Piercing Button Punch Side-Lap Connections.....	30
D1.2.7	Other Side-Lap Connections	30
D1.3	Diaphragm Shear Strength per Unit Length Controlled by Support Connection Strength Through Insulation, S_{nf}	31
D1.3.1	Lap-Up Condition at Side-Lap.....	32
D1.3.1.1	Lap-Up Condition With Side-Lap Fasteners Not Into Support.....	32
D1.3.1.2	Lap-Up Condition With Side-Lap Fasteners Into Support.....	33
D1.3.2	Lap-Down Condition at Side-Lap	33
D1.3.3	Other Support Fasteners Through Insulation.....	34
D1.4	Fluted Acoustic Panel With Perforated Elements.....	34
D1.5	Cellular Deck.....	34
D1.5.1	Safety Factors and Resistance Factors for Cellular Deck.....	34
D1.5.2	Connection Strength and Design.....	34
D1.6	Standing Seam Panels	35
D1.7	Double-Skinned Panels.....	36
D2	Stability Limit, S_{nb}	37
D2.1	Fluted Panel.....	37
D2.2	Cellular Deck.....	38
D3	Shear and Uplift Interaction.....	38
D3.1	Support Connections.....	38
D3.1.1	Arc Spot Welds.....	39
D3.1.2	Screws	40
D3.1.2.1	Screws Into Steel Supports	40
D3.1.2.2	Screws Through Bottom Flats Into Wood Supports	43
D3.1.3	Power-Actuated Fasteners.....	45
D3.1.4	Nails Through Bottom Flats Into Wood Supports	46
D3.2	Side-Lap Connections	47
D4	Steel Deck Diaphragms With Structural Concrete or Insulating Concrete Fills.....	47
D4.1	Safety Factors and Resistance Factors	47
D4.2	Structural Concrete-Filled Diaphragms	48
D4.3	Lightweight Insulating Concrete-Filled Diaphragms	48
D4.4	Perimeter Fasteners for Concrete-Filled Diaphragms.....	49
D4.4.1	Steel-Headed Stud Anchors	51
D5	Diaphragm Stiffness.....	51
D5.1	Stiffness of Fluted Panels.....	51
D5.1.1	Fluted Panels Without Perforated Elements	51
D5.1.2	Fluted Acoustic Panels With Perforated Elements	53
D5.2	Connection Flexibility	53
D5.2.1	Welds Into Steel.....	54

D5.2.1.1 Arc Spot or Arc Seam Welds.....	54
D5.2.1.2 Top Arc Seam Side-Lap Welds.....	54
D5.2.2 Screws Into Steel	54
D5.2.3 Wood Screws or Nails Into Wood Supports	55
D5.2.4 Power-Actuated Fasteners Into Supports.....	55
D5.2.5 Non-Piercing Button Punch Fasteners at Steel Panel Side-Laps	55
D5.2.6 Other Fasteners – Flexibility Determined by Tests	56
D5.3 Stiffness of Cellular Deck	56
D5.3.1 Cellular Deck Without Perforations.....	56
D5.3.2 Cellular Deck With Perforations.....	58
D5.4 Stiffness of Concrete-Filled Diaphragms	58
D5.4.1 Stiffness of Structural Concrete-Filled Diaphragms	58
D5.4.2 Stiffness of Insulating Concrete-Filled Diaphragms	59
D6 Diaphragm Flexibility	60
E. Diaphragm Nominal Shear Strength per Unit Length and Stiffness Determined by Test.....	61
E1 Strength and Stiffness of a Prototype Diaphragm System	61
E1.1 Test Protocol.....	61
E1.2 Design Using Test-Based Analytical Equations.....	61
E1.2.1 Test Assembly Requirements	62
E1.2.2 Test Calibration	64
E1.2.3 Laboratory Testing Reports	69
E2 Single Diaphragm System	69
E2.1 Test System Requirements	69
E2.1.1 Fastener and Weld Requirements	70
E2.1.2 Concrete Requirements	71
E2.2 Test Calibration.....	71
E2.3 Laboratory Testing Reports	72
E2.4 Adjustment for Design.....	72
E2.4.1 Adjustment to Strength of Diaphragms Without Structural Concrete Fill.....	73
E2.4.2 Adjustment to Strength of Diaphragms With Structural Concrete Fill.....	75
E2.5 Test Results Interpretation	76
APPENDIX 1: DETERMINATION OF FACTORS, D_n AND γ_c.....	78
1.1 General.....	78
1.1.1 Scope.....	78
1.1.2 Applicability.....	78
1.2 Determination of Warping Factor, D_n	78
1.3 Determination of Support Factor, γ_c	78
1.4 Determination of Warping Factor Where Insulation Is Not Present Beneath the Panel.....	79
1.5 Determination of Warping Factor Where Insulation Is Present Beneath the Panel.....	83
1.6 Determination of Warping Factor for Perforated Deck	84
APPENDIX 2: STRENGTH AT PERIMETER LOAD DELIVERY POINT	85
2.1 General.....	85
2.1.1 Scope.....	85
2.1.2 Applicability.....	85
2.2 Connection Design	85
2.3 Axial Compression Design in Panel	86
2.3.1 Combined Compressive Axial Load and Bending in Panel.....	87

2.4 Axial Tension Design in Panel..... 88
2.4.1 Combined Tensile Axial Load and Bending in Panel 88

List of Tables

Table B-1 Sections for Determining Safety and Resistance Factors	6
Table B1.1 Safety Factors and Resistance Factors for Diaphragms	7
Table D1.1.4.2-1 Wood Support Connection Strength	22
Table D1.1.4.2-2 Nail Penetration Required for Full Shear Strength	23
Table D1.1.4.3-1 Nominal Connection Shear Strength of Fastener With Full Penetration	25
Table E1.2-1 Essential Test Parameters	63
Table E1.2.2-1 Calibration Parameters β_o , F_m , M_m , V_F , V_M	66
Table E1.2.2-2 Additional Requirements for Safety and Resistance Factors	66
Table E2.4.1-1 Adjustment of Tested Nominal Diaphragm Strength, $S_{ni\ test}$ Due to Variations in Deck, Panel, Concrete Support or Insulating Fill Material From Specified Values	74
Table E2.4.2-1 Adjustment of Nominal Diaphragm Strength, $S_{ni\ test}$ due to Variations in Structural Concrete Fill Relative to Specified Values	75
Table 1.3-1 Support Factor, γ_c	78

List of Figures

D1-1 Schematic Illustration of Section D1 Parameters	14
AISI S100 J2.2.1-1 End and Edge Distance for Arc Spot Welds - Single Sheet	16
AISI S100 J2.2.1-2 End and Edge Distance for Arc Spot Welds - Double Sheet	16
AISI S100 J2.2.2.1-1 Arc Spot Weld – Single Thickness of Sheet.....	17
AISI S100 J2.2.2.1-2 Arc Spot Weld – Double Thickness of Sheet.....	17
AISI S100 J2.3.1-1 End and Edge Distances for Arc Seam Welds.....	18
AISI S100 J2.2-2 Arc Spot Weld Using Washer	19
D1.1.4.3-1 Fasteners Through Top Flat	25
AISI S100 J2.2.2.2-1 Arc Spot Weld – Sheet-to-Sheet.....	27
D1.2.4-1 Top Arc Seam Side-Lap Weld.....	29
D1.3-1 Fasteners Through Bottom at Interior Flutes Over Insulation.....	32
D1.3-2 Fasteners at Lap-Up	32
D1.3-3 Fasteners at Lap-Down.....	32
D1.3-4 Lap-Up With Fastener Through Top and Into Support.....	32
D1.7-1 Double-Skinned Panels.....	36
D2.1-1 Panel Configuration	37
D5.3.1-1 Cellular Deck Types	57
1.4-1 Panel Configuration	79
2.2-1 Free Body of Corner Fastener	86

NORTH AMERICAN STANDARD FOR THE DESIGN OF PROFILED STEEL DIAPHRAGM PANELS

A. GENERAL PROVISIONS

A1 Scope, Applicability, and Definitions

A1.1 Scope

This *Standard* applies to *diaphragms* and *wall diaphragms* that contain profiled steel *panels*, which include fluted *panels* or *deck*, and *cellular deck*. Unless noted otherwise, the term, *diaphragm*, applies to level and sloped roof *diaphragms* and to *wall diaphragms* as defined in Section A1.3. This *Standard* determines the *available strength [factored resistance]* and *stiffness* of steel *panels* and their *connections* in a *diaphragm* system, but does not address determination of *available strength [factored resistance]* for the other components in the system. The design of other *diaphragm* components is governed by the *applicable building code* and other design standards.

This *Standard* does not preclude the use of other materials, assemblies, structures or designs if the other materials, assemblies, structures or designs demonstrate equivalent performance for the intended use of those specified in this *Standard*. Where there is a conflict between this *Standard* and other reference documents, the requirements contained within this *Standard* govern.

This *Standard* consists of Chapters A through E, and Appendices 1 and 2.

A1.2 Applicability

The in-plane *nominal shear strength [resistance]* per unit length and *stiffness* of steel *diaphragm* or *wall diaphragm panels, deck, or cellular deck* shall be determined in accordance with this *Standard*. When calculation is used, the *nominal shear strength [resistance]* per unit length and *stiffness* shall be determined in accordance with Chapter D. When testing is used, the *nominal shear strength [resistance]* per unit length and *stiffness* shall be determined in accordance with Chapter E.

This *Standard* shall apply to roof or floor *diaphragms*, or *wall diaphragms* that are installed:

- (a) With or without insulation between the *panel* and the support,
- (b) Without insulation between the *cellular deck* and the support in accordance with Chapter D,
- (c) With insulation between the *cellular deck* and the support in accordance with Chapter E,
- (d) With or without concrete fill over the *deck* or *cellular deck*,
- (e) With or without *acoustic (perforated) panels* or *cellular acoustic deck*, and
- (f) With structural supports made of steel, wood, or concrete.

If the lateral stability or *diaphragm* action to resist in-plane lateral *loads* is provided by cold-formed steel framing with diagonal bracing or covered with structural wood, gypsum board, fiberboard, flat steel sheet or other flat panel sheathing, the design and installation shall be in accordance with AISI S240, AISI S400, and the *applicable building code*.

User Note:

Walls (vertical *diaphragms*) often are part of the lateral force-resisting system and may be subject to additional requirements by the *applicable building code*, particularly when resisting and dissipating seismic energy.

A1.3 Definitions

Where terms appear in this *Standard* in *italics*, such terms shall have the meaning as defined in this section or as defined in AISI S100 if they are not defined in this section. Terms included in square brackets shall be specific to *Limit States Design (LSD)* terminology. Terms not italicized shall have the ordinary accepted meaning in the context for which they are intended.

General Terms

Acoustic Panel. Fluted *panel* or *deck* containing holes. Holes are in discrete locations or throughout the coil width. Insulation often is installed behind the holes to improve sound absorption.

Cellular Acoustic Deck. *Cellular deck* with the bottom *deck* or flat sheet perforated to improve sound absorption. Holes are beneath the cavity formed with the top *deck* and fasteners are in either a perforated or non-perforated zone. Insulation often is installed in the cell cavity above the holes to improve sound absorption.

Cellular Deck. Composite or partially composite built-up *deck* formed by fastening either a flat steel sheet or a *panel* beneath and to another *panel*.

Composite Deck. Fluted *deck* or *cellular deck* that combines with *structural concrete* fill to form a slab with the *deck* as reinforcement. The fluted element has embossments, interlocking profile geometry, or other horizontal shear *connection* devices to develop mechanical bond between the *deck* and concrete so the slab compositely resists vertical and *diaphragm* shear loads.

Configuration. A specific arrangement of *panel* geometry, *thickness*, mechanical properties, span(s), and attachments that is unique to a test assembly.

Connection Flexibility. The property of a *connection* allowing local deflection caused by a unit load, and associated with *panel* distortion or slotting, and *connection* slip or strain.

Deck. A *panel* installed and covered by another membrane for weathertightness or by *structural* or *insulating concrete*.

Diaphragm. Roof, floor, or other horizontal or nearly horizontal membrane or bracing system that transfers in-plane forces to the *lateral force-resisting system*.

Double-Skinned Panel. A two-part built-up system that includes a bottom fluted *panel* fastened to supports. A sub-*girt* or other device is spaced periodically and fastened to the bottom fluted *panel*. A top fluted *panel* is both installed over and fastened to the sub-*girts* or other device. The top *panel* typically is not fastened directly to supports.

Edge Panel. Full or partial width *panel* that transfers in-plane forces to the *lateral force-resisting system* of the structure along a line that generally parallels the length of the *panel*.

Exterior Support. Support located at an end of an *edge* or *interior panel*.

Flexibility. The property of a *diaphragm* system that is the inverse of *stiffness*.

Form Deck. Fluted *deck* or *cellular deck* that chemically bonds with *structural concrete* or *insulating concrete* fill to form a slab that resists *diaphragm* shear loads. The *deck* resists the concrete dead load prior to concrete *compressive strength* being developed. Reinforcement is required in *structural concrete* to resist slab flexure.

Insulating Concrete. A mixture of Portland cement, cellular or expanded mineral concrete aggregate, and water forming a relatively lightweight concrete. When concrete is dried,

the aggregate porosity and air content provide insulating characteristics to roofs.

Interior Panel. Full or partial width *panel* that transfers in-plane forces to other *interior panels* or *edge panels*.

Interior Support. Support located at an interior zone of an *edge* or *interior panel*.

Interlocking Top Side-Lap Connection. A *connection* formed at a vertical sheet leg (edge stiffener of *panel*) inside an overlapping sheet hem, or at vertical legs back-to-back.

Lateral Force-Resisting System. The structural elements and *connections* required to resist racking and overturning due to wind forces, seismic forces, or the combination. The forces are imposed upon the structure in accordance with the *applicable building code*.

Panel. Product formed from steel coils into fluted profiles with top and bottom *flanges* connected by *web* members. Profile is connected to supports and can have a singular or a repeating pattern.

Pitch. Width of the repeating pattern of fluted *panel* measured from center-to-center.

Prototype Diaphragm System. A *diaphragm* system including a range of *configurations* that provide various combinations of profile, *thickness*, span, fastener type and pattern, support *thickness*, and edge detail.

Power-Actuated Fastener (PAF). Hardened steel fasteners driven through steel members into embedment material using either powder cartridges or compressed gas as the energy-driving source.

Side-Lap. Joint at which adjacent *panels* contact each other along a longitudinal edge.

Side-Lap Connection. Also called a *stitch connection*. A *connection* with a fastener or weld located at a *side-lap* while not penetrating a support.

Single Diaphragm System. A *diaphragm* system having a specific *configuration* with one set of profile, *thickness*, mechanical properties, span, fastener type and pattern, support type and *thickness*, fill type and thickness when applicable, and edge detail.

Shear Wall. Wall that provides *resistance* to lateral loads in the plane of the wall and provides stability for the structural system.

Standing Seam Panel. A roof *panel* having longitudinal (side) *joints* between the *panels* in a vertical position above the roof line. The roof *panel* system is secured to the roof substructure by means of concealed hold-down clips engaging the side *joint*.

Stiffness. The property of a *diaphragm* system resisting in-plane deflection.

Structural Concrete. A mixture of Portland or other hydraulic cement, fine aggregate, coarse aggregate and water, used for structural purposes, including plain and reinforced concrete.

Structural Connection. Also called a *support connection*. A *connection* with a fastener or weld attaching one or more sheets to supporting members.

Support Connection. See *structural connection*.

Top Arc Seam Side-Lap Welds. Arc seam welds applied at the top of an *interlocking top side-lap connection*.

Top Overlapping Side-Lap Connection. Welded, screwed, or mechanically formed or crimped *connection* located at or near the top of an overlapping *side-lap*. These *connections* are often concealed when viewed from below.

Wall Diaphragm. A wall, load bearing or non-load bearing, designed to resist forces acting in the plane of the wall (commonly referred to as a “vertical *diaphragm*” or “*shear wall*”).

A2 Materials

Profiled steel *panels* and cold-formed steel supports shall conform to the material requirements of AISI S100, Section A3.

Hot-rolled steel supports shall conform to the material requirements of ANSI/AISC 360.

Wood supports shall conform to the material requirements of ANSI/AWC NDS and shall be structural lumber.

Structural concrete shall conform to the material requirements of ACI 318.

Insulating concrete aggregate shall conform to ASTM C332.

A3 Loads

The *ASD* or *LRFD loads*, *load factors* and *load combinations* shall be determined in accordance with the *applicable building code*. In the absence of an *applicable building code*, ASCE 7 shall apply.

Load factors and *load combinations* for *LSD* shall be as stipulated by AISI S100 Section B2.

A4 Referenced Documents

The following documents or portions thereof are referenced in this *Standard* and shall be considered part of the requirements of this *Standard*.

1. American Concrete Institute (ACI), 38800 Country Club Dr., Farmington Hills, MI 48331:
ACI 318-11, Building Code Requirements for Structural Concrete
2. American Iron and Steel Institute (AISI), 25 Massachusetts Avenue, NW, Suite 800, Washington, DC 20001:
AISI S100-16, North American Specification for the Design of Cold-Formed Steel Structural Members
AISI S240-15, North American Standard for Cold-Formed Steel Structural Framing
AISI S400-15, North American Standard for Seismic Design of Cold-Formed Steel Structural Systems
AISI S904-13, Standard Test Methods for Determining the Tensile and Shear Strength of Screws
AISI S905-13, Test Standard for Cold-Formed Steel Connections
AISI S907-13, Test Standard for Cantilever Test Method for Cold-Formed Steel Diaphragms
3. American Institute of Steel Construction (AISC), One East Wacker Drive, Suite 700, Chicago, IL 60601-1802
ANSI/AISC 360-10, Specification for Structural Steel Buildings
4. American Society of Civil Engineers (ASCE), 1801 Alexander Bell Drive, Reston, VA 20191 – 4400
ASCE/SEI 7-10 Including Supplement No. 1, Minimum Design Loads for Buildings and Other Structures
5. American Welding Society (AWS), 550 N. W. LeJeune Road, Miami, FL 33135
ANSI/AWS D1.1/D1.1M-10, Structural Welding Code - Steel
ANSI/AWS D1.3/D1.3M-08, Structural Welding Code – Sheet Steel
6. ASTM International (ASTM), 100 Barr Harbor Drive, PO Box C700, West Conshohocken, PA, 19428-2959

ASTM C33/C33M-13, *Standard Specifications for Concrete Aggregates*

ASTM C330/C330M-14, *Standard Specification for Lightweight Aggregates for Structural Concrete*

ASTM C332-09, *Standard Specification for Lightweight Aggregates for Insulating Concrete*

ASTM D1761-12, *Standard Test Methods for Mechanical Fasteners in Wood*

ASTM E488/E488M-10, *Standard Test Methods for Strength of Anchors in Concrete Elements*

ASTM E1190-11, *Standard Test Methods for Strength of Power-Actuated Fasteners Installed in Structural Members*

ASTM F1667-13, *Standard Specification for Driven Fasteners: Nails, Spikes, and Staples*

7. American Wood Council, 1111 Nineteenth Street, NW, Suite 800, Washington, DC 20036

ANSI/AWC NDS-2012, *National Design Specification (NDS) for Wood Construction*

A5 Units of Symbols and Terms

Any compatible system of measurement units is permitted to be used in the *Standard* except where explicitly stated otherwise. The unit systems considered shall include U.S. Customary units (force in kilopounds (kip) and length in inches (in.)), and SI units (force in Newtons (N) and length in millimeters (mm)).

B. SAFETY FACTORS AND RESISTANCE FACTORS

The *safety* and *resistance factors* for *diaphragm* systems shall be determined in accordance with Table B-1.

Table B-1
Sections for Determining Safety and Resistance Factors

Diaphragm System Conditions	Applicable AISI S310 Sections	
	Diaphragm Strength Determined by Calculation Using Chapter D	Diaphragm Strength Determined by Tests Using Chapter E
Steel support and no concrete fill	Sections B1, D1.1.5	Sections E1.2.2, E2.2
Wood supports	Sections D1.1.4.1, D1.1.5	Sections E1.2.2, E2.2
Structural concrete supports	Section D1.1.5	Section E1.2.2
Structural concrete fill	Section D4.1	Section E1.2.2
Insulating concrete fill	Section D4.1	Section E1.2.2

B1 Safety Factors and Resistance Factors of Diaphragms With Steel Supports and No Concrete Fill

For *diaphragms* or *wall diaphragms* with steel support and no concrete fill, the *safety* and *resistance factors* shall be determined in accordance with Section B1.1.

B1.1 Floor, Roof, or Wall Steel Diaphragm Construction

The in-plane *diaphragm nominal shear strength [resistance]*, S_n , shall be established by calculation or test. The *safety factors* and *resistance factors* for *diaphragms* given in Table B1.1 shall apply to calculations or tests. The *safety factors* and *resistance factors* for tests shall be determined in accordance with Section E1.2.2 or Section E2.2 of this *Standard*, as applicable. However, the more severe factor from calibration and Table B1.1 shall be used unless noted otherwise in the *Standard*. If the *nominal shear strength [resistance]* is only established by test without defining all limit state thresholds, the *safety factors* and *resistance factors* shall also be limited by the values given in Table B1.1 for *connection* types and *connection-related* failure modes. The more severe factored limit state shall control the design. Where a combination of connection types are used within a *diaphragm configuration*, the more severe factor shall be used.

Ω_d = As specified in Table B1.1 (*ASD*)

ϕ_d = As specified in Table B1.1 (*LRFD* and *LSD*)

Table B1.1
Safety Factors and Resistance Factors for Diaphragms

Load Type or Combinations Including	Connection Type	Limit State					
		Connection-Related			Panel Buckling ¹		
		Ω_d (ASD)	ϕ_d (LRFD)	ϕ_d (LSD)	Ω_d (ASD)	ϕ_d (LRFD)	ϕ_d (LSD)
Wind	Welds	2.15	0.75	0.60	2.00	0.80	0.75
	Screws	2.00	0.80	0.75			
Earthquake and All Others	Welds	3.00	0.55	0.40			
	Screws	2.30	0.70	0.55			

Note:

¹ Panel buckling is out-of-plane buckling and not local buckling at fasteners.

For mechanical fasteners other than screws:

- (a) Ω_d shall not be less than the Table B1.1 values for screws, and
- (b) ϕ_d shall not be greater than the Table B1.1 values for screws.

In addition, the value of Ω_d and ϕ_d using mechanical fasteners other than screws shall be limited by the Ω and ϕ values established through calibration of the individual fastener shear strength in accordance with Section D1.1.5, unless sufficient data exist to establish a *diaphragm* system effect in accordance with Section E1.2. Fastener shear strength calibration shall include the *diaphragm* material type.

If the *nominal shear strength [resistance]* per unit length of the *diaphragm* is established by test in accordance with AISI S907 or a *connection strength* of the *diaphragm* is established by test in accordance with AISI S905, the *safety* and *resistance factors* shall be determined in accordance with Section E1.2.2 or Section E2.2 of this *Standard*, as applicable. The test assembly shall be such that the tested failure mode is representative of the design. The impact of the *thickness* of the supporting material on the failure mode shall be included in the test, if applicable.

User Note:

Panel buckling is discussed in the Commentary of Section D2 and does not include bowing or warping of panels between support fasteners at panel ends. See Sections D2.1 and D2.2.

Mechanical fasteners include screws, power-actuated fasteners, or other mechanical connections.

Diaphragm system effect is established through tests in accordance with AISI S907.

C. DIAPHRAGM AND WALL DIAPHRAGM DESIGN

C1 General

The design of *diaphragm* and *wall diaphragm* systems shall be based on calculation or testing. *Diaphragm* or *wall diaphragm* system chords, ties, collectors, support framing, supplemental in-plane bracing systems, and the associated details and *connections* shall be designed in accordance with the applicable design standard for the material used. The in-plane shear strength per unit length and *stiffness* for *panels* or *decks* used as components of a *diaphragm* or *wall diaphragm* system shall be determined in accordance with this *Standard*.

Loads and *load combinations* shall be determined in accordance with Section A3.

The application of profiled steel *panels* or *decks* as a component of a *diaphragm* or *wall diaphragm* system shall meet the system limitations in the *applicable building code*.

User Note:

System limitations might include *diaphragm* span-to-depth ratio or *flexibility* limits.

C2 Strength Design

The *available shear strength* [*factored resistance*] per unit length of *deck* and *panels* shall satisfy the following equations:

For ASD,

$$R \leq \frac{S_n}{\Omega} \quad (\text{Eq. C2-1})$$

where

R = Required strength for ASD

S_n = Nominal shear strength per unit length of *diaphragm* system as specified in Chapter D or E

Ω = Safety factor for *diaphragm strength* determined in accordance with Table B-1

For LRFD,

$$R_u \leq \phi S_n \quad (\text{Eq. C2-2})$$

where

R_u = Required strength for LRFD

ϕ = Resistance factor for *diaphragm strength* determined in accordance with Table B-1

For LSD,

$$\phi S_n \geq R_f \quad (\text{Eq. C2-3})$$

where

R_f = Effect of *factored loads* for LSD

ϕ = Resistance factor for *diaphragm resistance* determined in accordance with Table B-1

C3 Deflection Requirements

Diaphragm deflection under load shall satisfy Eq. C3-1.

$$\delta_n \leq \delta_a \quad (\text{Eq. C3-1})$$

where

δ_n = Calculated *diaphragm* deflection at the load determined in accordance with Section A3

δ_a = Allowable *diaphragm* deflection defined by the *applicable building code* and the structure's service requirements

Deflection, δ_{iv} , is determined using *stiffness* or *flexibility* analytical methods. *Diaphragm stiffness* of the *deck* or *panel*, G' , shall be determined in accordance with Section D5. *Diaphragm flexibility* of the *deck* or *panel*, F , shall be determined in accordance with Section D6.

D. DIAPHRAGM NOMINAL SHEAR STRENGTH PER UNIT LENGTH AND STIFFNESS DETERMINED BY CALCULATION

This section shall apply to fluted *panels* or *deck* within the following limits:

- (a) 0.5 in. (12 mm) \leq *panel* or *deck* depth \leq 7.5 in. (191 mm),
- (b) 0.014 in. (0.35 mm) \leq base *panel* or *deck* thickness \leq 0.075 in. (1.91 mm) for depth less than or equal to 3.0 in. (76.2 mm),
0.034 in. (0.85 mm) \leq base *panel* or *deck* thickness \leq 0.075 in. (1.91 mm) for depth greater than 3.0 in. (76 mm),
- (c) 33 ksi (230 MPa) \leq specified F_y of *panel* or *deck* \leq 80 ksi (550 MPa),
45 ksi (310 MPa) \leq specified F_u of *panel* or *deck* \leq 82 ksi (565 MPa), and
- (d) *Panel* or *Deck* pitch \leq 12 in. (305 mm).

Additional requirements shall be satisfied for *panels* over insulation at supports as specified in Section D1.3, and *cellular decks* as specified in Section D1.5.

The *available shear strength* [*factored resistance*] per unit length of a *diaphragm* or *wall diaphragm* system shall be the lower value obtained from the *limit states* controlled by either *connection* strength or *panel out-of-plane buckling* strength.

$$\frac{S_n}{\Omega} = \min\left(\frac{S_{nf}}{\Omega_{df}}, \frac{S_{nb}}{\Omega_{db}}\right) \quad \text{for ASD} \quad (\text{Eq. D-1})$$

$$\phi S_n = \min(\phi_{df} S_{nf}, \phi_{db} S_{nb}) \quad \text{for LRFD and LSD} \quad (\text{Eq. D-2})$$

where

S_n = Nominal shear strength [*resistance*] per unit length of *diaphragm* system

S_{nf} = Nominal shear strength [*resistance*] per unit length of *diaphragm* system controlled by *connections* and in accordance with Section D1

S_{nb} = Nominal shear strength [*resistance*] per unit length of *diaphragm* system controlled by *panel out-of-plane buckling* and in accordance with Section D2

ϕ = Resistance factor for *diaphragm* strength determined in accordance with Table B-1

ϕ_{df} = Resistance factor for *diaphragm* strength controlled by *connections* and in accordance with Table B-1

ϕ_{db} = Resistance factor for *diaphragm* strength controlled by *panel out-of-plane buckling* and in accordance with Table B-1

Ω = Safety factor for *diaphragm* strength determined in accordance with Table B-1

Ω_{df} = Safety factor for *diaphragm* strength controlled by *connections* and in accordance with Table B-1

Ω_{db} = Safety factor for *diaphragm* strength controlled by *panel out-of-plane buckling* and in accordance with Table B-1

The steel edge dimensions at *side-laps*, *end-laps*, and *end butt joints* shall meet the requirements for *connections* specified in AISI S100.

User Note:

ϕ_{df} and ϕ_{db} , or Ω_{df} and Ω_{db} , are subsets of ϕ or Ω and indicate that two *limit states* must be investigated to determine the *available shear strength* [*factored resistance*] per unit length of *panels*.

D1 Diaphragm Shear Strength per Unit Length Controlled by Connection Strength, S_{nf}

The *nominal shear strength [resistance]* per unit length of a *diaphragm* or *wall diaphragm* controlled by *connection strength*, S_{nf} , shall be the smallest of S_{ni} , S_{nc} , and S_{ne} .

$$S_{ni} = [2A(\lambda - 1) + \beta] \frac{P_{nf}}{L} \quad (\text{Eq. D1-1})$$

$$S_{nc} = \left(\frac{N^2 \beta^2}{L^2 N^2 + \beta^2} \right)^{0.5} P_{nf} \quad (\text{Eq. D1-2})$$

$$S_{ne} = \frac{(2\alpha_1 + n_p \alpha_2) P_{nf} + n_e P_{nfs}}{L} \quad (\text{Eq. D1-3})$$

where

S_{ni} = *Nominal shear strength [resistance]* per unit length of *diaphragm* or *wall diaphragm* controlled by *connections at interior panels* or *edge panels*

S_{nc} = *Nominal shear strength [resistance]* per unit length of *diaphragm* or *wall diaphragm* controlled by *support connections at the corners of interior panels* or *edge panels*

S_{ne} = *Nominal shear strength [resistance]* per unit length of *diaphragm* or *wall diaphragm* controlled by *connections along the edge parallel to the panel span in an edge panel* and located at a *diaphragm reaction line*

A = Number of *exterior support connections* per flute located at the *side-lap* at an *interior panel* or *edge panel end*

λ = *Connection strength reduction factor at corner fastener*, unitless

$$= 1 - \frac{D_d L_v}{240 \sqrt{t}} \geq 0.7 \quad \text{for U.S. Customary units} \quad (\text{Eq. D1-4a})$$

$$= 1 - \frac{D_d L_v}{369 \sqrt{t}} \geq 0.7 \quad \text{for SI units} \quad (\text{Eq. D1-4b})$$

where

D_d = *Depth of panel*, in. (mm). See Figure D2.1-1

L_v = *Span of panel between supports with fasteners*, ft (m)

t = *Base metal thickness of the panel*, in. (mm)

β = *Factor defining connection contribution and interaction to diaphragm shear strength per unit length*

$$= n_s \alpha_s + 2n_p \alpha_p^2 + 4\alpha_e^2 \quad (\text{Eq. D1-5})$$

n_s = Number of *side-lap connections* along a total *panel length, L*, and not into supports

$$\alpha_s = \frac{P_{ns}}{P_{nf}} \quad (\text{Eq. D1-6})$$

P_{nf} = *Nominal shear strength [resistance]* of a *support connection per fastener*

P_{ns} = *Nominal shear strength [resistance]* of a *side-lap connection per fastener*

n_p = Number of *interior supports* along a total *panel length, L*

α_p^2 = *Analogous section modulus of panel interior support connection group in an interior or edge panel*

$$= \left(\frac{1}{w^2} \right) \sum x_p^2 \quad (\text{Eq. D1-7})$$

$$\begin{aligned} w &= \text{Panel cover width} \\ x_p &= \text{Distance from panel center line to an interior support structural connection in a panel} \\ \alpha_e^2 &= \text{Analogous section modulus of panel exterior support fastener group in an interior or edge panel} \\ &= \left(\frac{1}{w^2} \right) \sum x_e^2 \end{aligned} \quad (\text{Eq. D1-8})$$

$$\begin{aligned} x_e &= \text{Distance from panel center line to an exterior support structural connection in a panel} \\ L &= \text{Total panel length} \\ &= (n_p + 1)L_v \text{ for equal spans} \end{aligned} \quad (\text{Eq. D1-9})$$

$$\begin{aligned} N &= \text{Number of support fasteners per unit width at an interior or edge panel's end} \\ \alpha_1 &= \text{Measure of exterior support fastener group distribution across a panel width, } w_e, \text{ at an edge panel} \\ &= \frac{\sum x_{ee}}{w_e} \end{aligned} \quad (\text{Eq. D1-10})$$

$$\begin{aligned} x_{ee} &= \text{Distance from panel center line to an exterior support structural connection in an edge panel} \\ w_e &= \text{Panel cover width at the edge panel} \\ \alpha_2 &= \text{Measure of interior support fastener group distribution across a panel width, } w_e, \text{ at an edge panel} \\ &= \frac{\sum x_{pe}}{w_e} \end{aligned} \quad (\text{Eq. D1-11})$$

$$\begin{aligned} x_{pe} &= \text{Distance from panel center line to an interior support structural connection in an edge panel} \\ n_e &= \text{Number of edge support connections between transverse supports and along an edge panel length, } L \\ P_{nfs} &= \text{Nominal shear strength [resistance] of an edge support connection installed parallel with an edge panel span and between transverse supports} \end{aligned}$$

See Figure D1-1 for an illustration of the parameters in Section D1.

For $L_v > 5.00$ ft (1.52 m), the spacing of *side-lap connections* between supports shall not exceed 3.00 ft (0.914 m), and the spacing of edge fasteners between supports shall not exceed 3.00 ft (0.914 m).

P_{nf} shall be determined in accordance with Section D1.1, and P_{ns} shall be determined in accordance with Section D1.2. If the *support connection* is subjected to combined shear and tension, P_{nf} shall be reduced in accordance with Section D3.

P_{nfs} used to determine S_{ne} in accordance with Eq. D1-3 shall be calculated as follows:

- (a) P_{nfs} is determined in accordance with Section D1.1 where the *connection* is through the bottom flat of a *panel* with the gap between the *panel* bottom and the edge support less than or equal to 3/8 in. (9.53 mm), and
- (b) $P_{nfs} = 0.0$ for *connections* through the top flat of a *panel* or through the bottom flat of a *panel* where the gap between the *panel* bottom and the edge support is greater than 3/8 in. (9.53 mm).

User Note:

Some *connection* installation does not allow a gap. Consult the fastener manufacturer's recommendations or refer to AWS D1.3, as applicable.

Where P_{nfs} would otherwise be negligible ($P_{nfs} = 0.0$), the designer should provide a detail that is capable of transferring the *diaphragm* shear force (reaction) from the *edge panel* to the edge support at the *lateral force-resisting system* line. If the *diaphragm* shear force per unit length can flow across a potential *lateral force-resisting system* to another *lateral force-resisting system* without exceeding the *available strength [factored resistance]* of the *diaphragm* system, the detail can be avoided.

A reaction line is where *diaphragm* shear force per unit length transfers to a *lateral force-resisting system*. The *panel* width, w_e , is the distance from the adjacent *interior panel side-lap* to the reaction line in determining the *nominal diaphragm shear strength [resistance]* per unit length at an *edge panel*, S_{nf} (smallest of S_{ni} , S_{nc} , and S_{ne}).

Installations with insulation between the *panel* and the edge support are discussed in Section D1.3 and are consistent with the Section D1 requirements.

User Note:

S_{nx} and S_{ny} , as shown in Figure D1-1, indicate a possible shear flow along the orthogonal axes x and y and clarify that the required S_n can be a variable along the *diaphragm* span, L_d , between *lateral force-resisting systems*.

Appendix 2 presents a particular case of S_{nc} with *loads* delivered through perimeter *connections*. The *nominal diaphragm shear strengths [resistances]* per unit length, S_{ni} , S_{nc} , and S_{ne} , are subsets of S_{nf} , and the *safety* and *resistance factors* controlled by *connections* apply to each subset for the applicable connections. See Table B1.1 in Section B1.

Eqs. D1-1 or D1-2 can control *nominal shear strength [resistance]* per unit length at either an *edge* or *interior panel*. Both *panel* locations must be investigated when the fastener pattern or *panel* width varies between the *interior* and *edge panels*. Eq. D1-3 only applies at locations of *load* transfer along *lateral force-resisting system* lines or along *load* delivery members (*struts*).

When *diaphragm* shear per unit length is flowing from two sides into a *lateral force-resisting system*, the *required strength [reaction]* per unit length rather than the maximum shear per unit length in the panel is compared with the *available shear strength [factored resistance]* per unit length. *Available shear strength [factored resistance]* is S_{ne}/Ω for ASD and ϕS_{ne} for LRFD or LSD, where S_{ne} is determined in accordance with Eq. D1-3.

To develop *edge support connection resistance* at each of the n_e fasteners between *panel* supports, the designer must require edge supports between the perpendicular supports. The edge supports are generally parallel with the *panel* span or the building edge and must be in the *diaphragm* support plane to allow attachment.

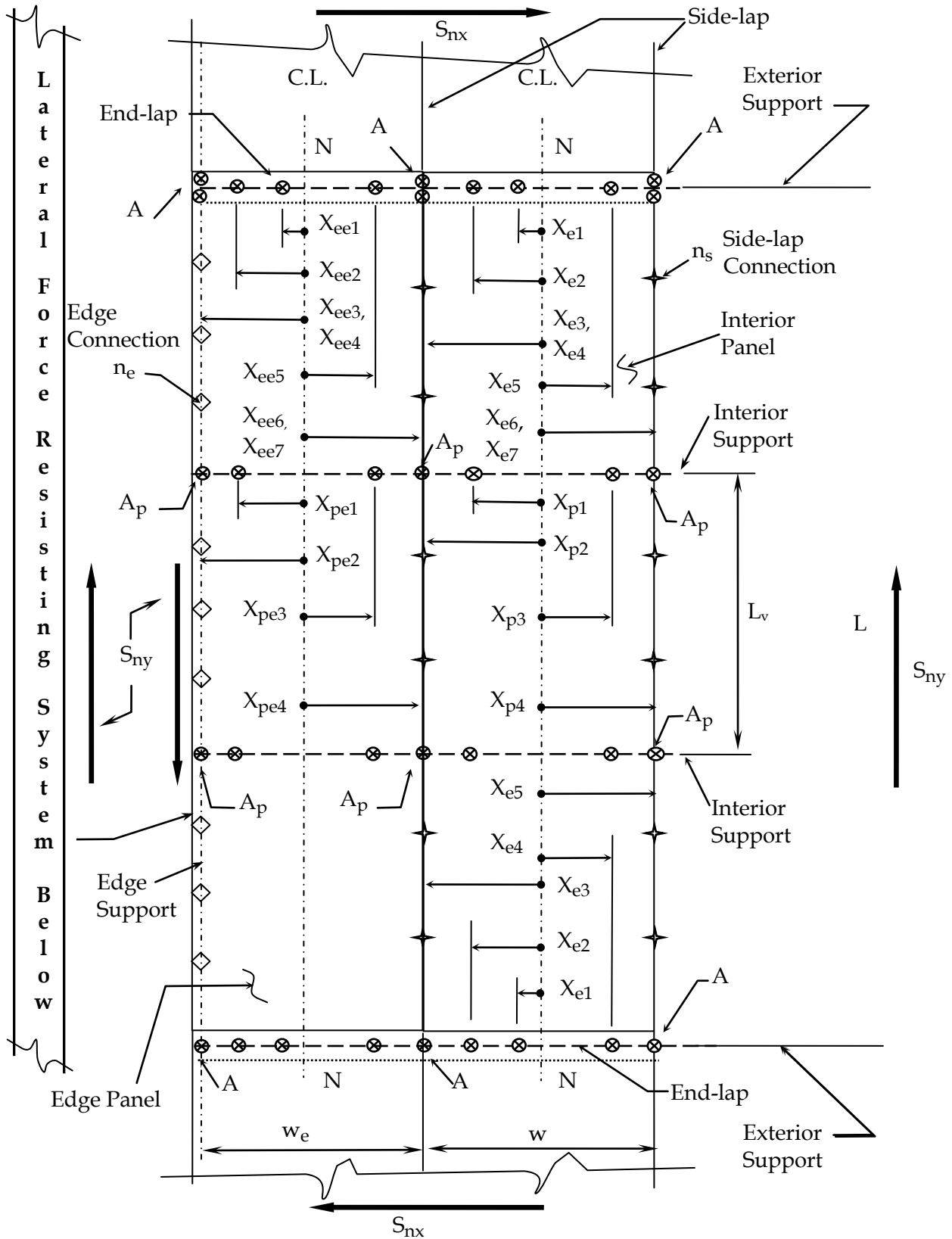

Figure D1-1 Schematic Illustration of Section D1 Parameters

D1.1 Support Connection Shear Strength in Fluted Deck or Panels, P_{nf} and P_{nfs}

The *nominal shear strength [resistance]* of a *connection* per support fastener, P_{nf} , and per fastener at an edge, P_{nfs} , shall be calculated in accordance with (a) or determined by tests in accordance with (b).

(a) *Nominal Connection Shear Strength [Resistance]* Determined by Calculation

Connection strength shall be calculated in accordance with Sections D1.1.1 through D1.1.4, as applicable. Design values of F_y and F_u used in these sections shall be modified in accordance with AISI S100 Section A3.1.2 or A3.1.3 for steels not conforming to AISI S100 Section A3.1.1 unless noted otherwise.

(b) *Nominal Connection Shear Strength [Resistance]* Determined by Test

Tests shall be performed to determine the *nominal connection shear strength [resistance]* in accordance with Section D1.1.5.

User Note:

P_{nf} is used to calculate S_{ni} in Eq. D1-1 and S_{nc} in Eq. D1-2, while P_{nfs} is used to calculate S_{ne} in Eq. D1-3. The *connection* detail and location in the *panel* can affect the ability to develop both P_{nf} and P_{nfs} so they are not always the same value. The impact of details on P_{nfs} is discussed in Sections D1 and D1.3.

D1.1.1 Arc Spot Welds or Arc Seam Welds on Steel Supports

Arc spot welding and arc seam welding shall conform to AWS D1.3. Arc spot and arc seam welds shall be for welding steel sheet to thicker supporting members or sheet-to-sheet in the flat position. Arc spot welds (puddle welds) shall not be made on steel supports where the thinnest sheet exceeds 0.15 in. (3.81 mm) in *thickness*, nor through a combination of steel sheets having a total *thickness* over 0.15 in. (3.81 mm). The *nominal shear strength [resistance]* of arc spot welds and arc seam welds without washer shall be determined in accordance with AISI S100 Sections J2.2.2.1 and J2.3.2.1, and meet the edge and end distance requirements in accordance with AISI S100 Sections J2.2.1 and J2.3.1, respectively.

Note:

The following two revisions are made in the extracted AISI S100 Sections J2.2.1 and J2.3.1:

- (1) The *safety* and *resistance factors* and the design methods in AISI S100 Sections J2.2.2.1 and J2.3.2.1 do not apply. The *safety* and *resistance factors* are determined in accordance with Table B-1.
- (2) This *Standard's* symbols, P_{nf} or P_{nfs} , are inserted for consistent terminology.

[Beginning of Extraction]

AISI S100 J2.2.1 Minimum Edge and End Distance

The distance from the centerline of an arc spot weld to the end or edge of the connected member shall not be less than 1.5d. In no case shall the clear distance between welds and the end or edge of the member be less than 1.0d, where d is the visible diameter of the outer surface of the arc spot weld. See AISI S100 Figures J2.2.1-1 and J2.2.1-2 for details.

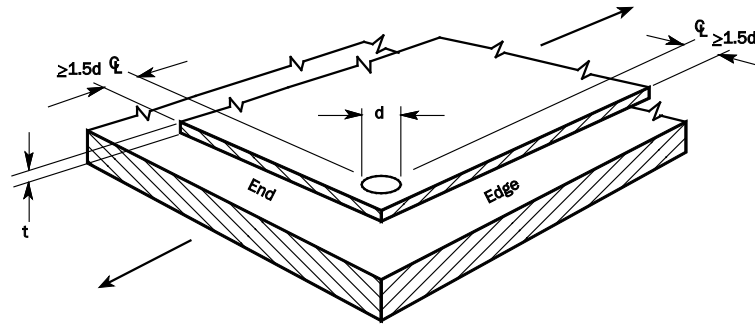

AISI S100 Figure J2.2.1-1 End and Edge Distance for Arc Spot Welds – Single Sheet

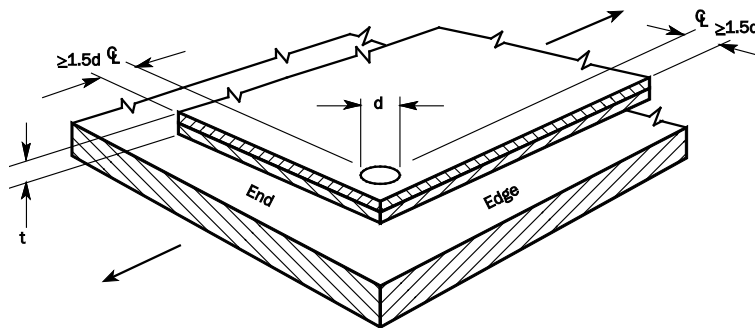

AISI S100 Figure J2.2.1-2 End and Edge Distance for Arc Spot Welds – Double Sheet

AISI S100 J2.2.2.1 Shear Strength for Sheet(s) Welded to a Thicker Supporting Member

The *nominal shear strength [resistance]*, P_{nf} or P_{nfs} , of each arc spot weld between the sheet or sheets and a thicker supporting member shall be determined by using the smaller of either (a) or (b).

$$(a) P_{nf} = \frac{\pi d_e^2}{4} 0.75 F_{xx} \quad (\text{AISI S100 Eq. J2.2.2.1-1})$$

$$(b) \text{ For } (d_a/t) \leq 0.815 \sqrt{E/F_u} \\ P_{nf} = 2.20 t d_a F_u \quad (\text{AISI S100 Eq. J2.2.2.1-2})$$

$$\text{For } 0.815 \sqrt{E/F_u} < (d_a/t) < 1.397 \sqrt{E/F_u}$$

$$P_{nf} = 0.280 \left[1 + 5.59 \frac{\sqrt{E/F_u}}{d_a/t} \right] t d_a F_u \quad (\text{AISI S100 Eq. J2.2.2.1-3})$$

$$\text{For } (d_a/t) \geq 1.397 \sqrt{E/F_u}$$

$$P_{nf} = 1.40 t d_a F_u \quad (\text{AISI S100 Eq. J2.2.2.1-4})$$

where

P_{nf} = *Nominal shear strength [resistance]* of arc spot weld

d_e = *Effective diameter of fused area at plane of maximum shear transfer*

$$= 0.7d - 1.5t \leq 0.55d \quad (\text{AISI S100 Eq. J2.2.2.1-5})$$

where

- d = Visible diameter of outer surface of arc spot weld
- t = Total combined base steel *thickness* (exclusive of coatings) of sheets involved in shear transfer above plane of maximum shear transfer
- F_{xx} = Tensile strength of electrode classification
- d_a = Average diameter of arc spot weld at mid-thickness of t where $d_a = (d - t)$ for single sheet or multiple sheets not more than four lapped sheets over a supporting member. See AISI S100 Figures J2.2.2.1-1 and J2.2.2.1-2 for diameter definitions.
- E = Modulus of elasticity of steel
- F_u = Tensile strength of sheet as determined in accordance with AISI S100 Section A3.1 or A3.2

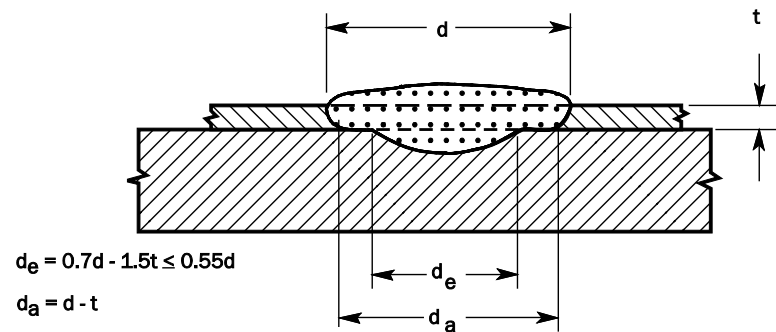

AISI S100 Figure J2.2.2.1-1 Arc Spot Weld - Single Thickness of Sheet

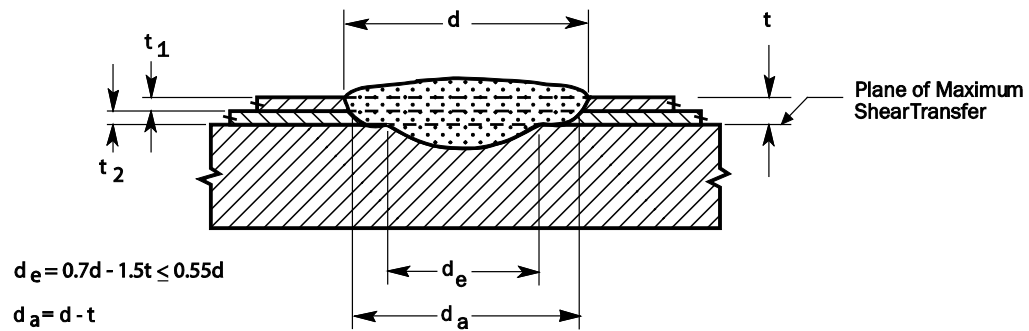

AISI S100 Figure J2.2.2.1-2 Arc Spot Weld - Double Thickness of Sheet

AISI S100 J2.3.1 Minimum Edge and End Distance

The distance from the center line of an arc seam weld to the end or edge of the connected member shall not be less than $1.5d$. In no case shall the clear distance between welds and the end or edge of the member be less than $1.0d$. See AISI S100 Figure J2.3.1-1 for details.

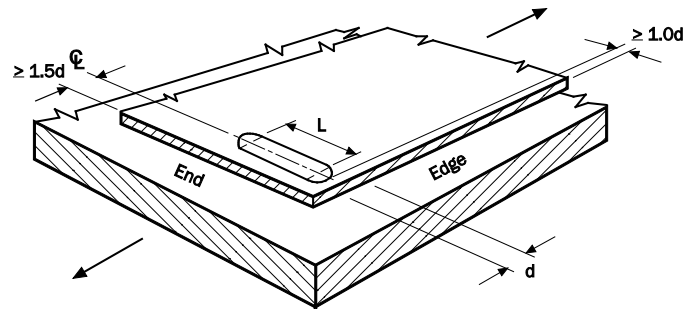

AISI S100 Figure J2.3.1-1 End and Edge Distances for Arc Seam Welds

AISI S100 J2.3.2.1 Shear Strength for Sheet(s) Welded to a Thicker Supporting Member

The *nominal shear strength [resistance]*, P_{nf} or P_{nfs} , of arc seam welds shall be determined by using the smaller of either AISI S100 Eq. J2.3.2.1-1 or Eq. J2.3.2.1-2.

$$P_{nf} = \left[\frac{\pi d_e^2}{4} + L d_e \right] 0.75 F_{xx} \quad (\text{AISI S100 Eq. J2.3.2.1-1})$$

$$P_{nf} = 2.5 t F_u (0.25 L + 0.96 d_a) \quad (\text{AISI S100 Eq. J2.3.2.1-2})$$

where

P_{nf} = *Nominal shear strength [resistance]* of arc seam weld

d_e = Effective width of seam weld at fused surfaces

$$= 0.7d - 1.5t \quad (\text{AISI S100 Eq. J2.3.2.1-3})$$

where

d = Visible width of arc seam weld

L = Length of seam weld not including circular ends
(For computation purposes, L shall not exceed $3d$)

d_a = Average width of seam weld

$$= (d - t) \text{ for single or double sheets} \quad (\text{AISI S100 Eq. J2.3.2.1-4})$$

F_u , F_{xx} , and t = Values as defined in AISI S100 Section J2.2.2.1

[End of Extraction]

For arc spot welds with washers, the *nominal shear strength [resistance]*, P_{nf} or P_{nfs} , shall be the lesser of AISI S100 Eq. J2.2.2.1-1 and Eq. D1.1.1-1. To determine d_e in AISI S100 Eq. J2.2.2.1-5, d shall be replaced by d_o and t shall be the *thickness* of the elements below the washer.

Eqs. D1.1.1-1a and D1.1.1-1b shall apply with the following limits:

- (a) $d_o \geq 3/8$ in. (9.53 mm),
 (b) 0.05 in. (1.27 mm) < washer *thickness* < 0.08 in. (2.03 mm), and
 (c) Washer *tensile strength*, $F_{u \text{ washer}} \geq 45$ ksi (310 MPa), and is permitted to be less than the *tensile strength* of the element to be welded.

$$P_{nf} = 99t(1.33d_o + 0.3F_{xx}t) \quad \text{in U.S. customary units} \quad (\text{Eq. D1.1.1-1a})$$

$$P_{nf} = 17.3t \left(\frac{d_o}{19.1} + \frac{F_{xx}t}{584} \right) \quad \text{in SI units} \quad (\text{Eq. D1.1.1-1b})$$

where

d_o = Hole diameter in washer, in. (mm)

t = Total combined base steel *thickness* (exclusive of coatings) of sheets beneath the washer and above the shear transfer plane, in. (mm)

F_{xx} = *Tensile strength* of electrode classification, ksi (MPa)

P_{nf} = *Nominal shear strength [resistance]* of arc spot weld with washer, kip (kN)

See AISI S100 Figure J2.2-2 for details.

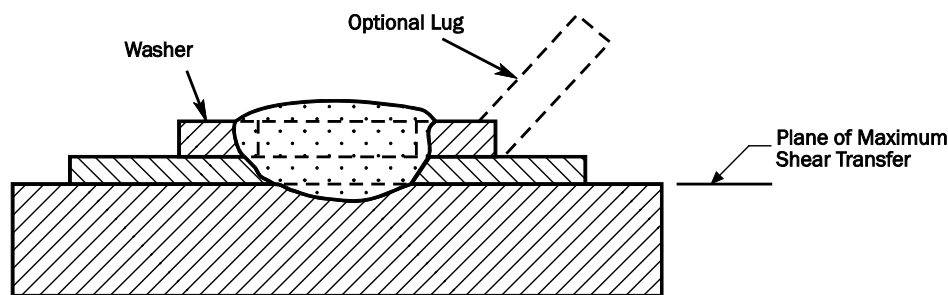

AISI S100 Figure J2.2-2 Arc Spot Weld Using Washer

D1.1.2 Screws Into Steel Supports

The minimum spacing, minimum edge and minimum end distances for screws shall satisfy the requirements as specified in AISI S100 Sections J4.1 and J4.2. The *connection nominal shear strength [resistance]* per screw, P_{nf} or P_{nfs} , shall be determined in accordance with AISI S100 Section J4.3.

User Note:

In AISI S100 Section J4.3:

d = *Nominal* screw diameter

t_1 = *Thickness* of member in contact with screw head or washer

t_2 = *Thickness* of member not in contact with screw head or washer

F_{u1} = *Tensile strength* of member in contact with screw head or washer

F_{u2} = *Tensile strength* of member not in contact with screw head or washer

Eqs. AISI S100 J4.3.1-1 through J4.3.1-5 provide P_{nf} but the same equations also provide P_{nfs} at supports unless noted otherwise.

Note:

The following two revisions are made in the extracted AISI S100 Section J4.3.1:

- (1) The term, P_{nf} , is substituted for P_{nv} and is consistent with *support connection* terminology in Sections D1 and D1.1.
- (2) Section D1.2.5 refers to Section D1.1.2, and application of this section then provides P_{ns} consistent with *side-lap connection* terminology in Sections D1 and D1.2.

[Beginning of Extraction]**AISI S100 J4.3.1 Shear Strength Limited by Tilting and Bearing**

The *nominal shear strength [resistance]* of sheet per screw, P_{nf} , shall be determined in accordance with this section.

For $t_2/t_1 \leq 1.0$, P_{nf} shall be taken as the smallest of

$$P_{nf} = 4.2 (t_2^3 d)^{1/2} F_{u2} \quad (\text{AISI S100 Eq. J4.3.1-1})$$

$$P_{nf} = 2.7 t_1 d F_{u1} \quad (\text{AISI S100 Eq. J4.3.1-2})$$

$$P_{nf} = 2.7 t_2 d F_{u2} \quad (\text{AISI S100 Eq. J4.3.1-3})$$

For $t_2/t_1 \geq 2.5$, P_{nf} shall be taken as the smaller of

$$P_{nf} = 2.7 t_1 d F_{u1} \quad (\text{AISI S100 Eq. J4.3.1-4})$$

$$P_{nf} = 2.7 t_2 d F_{u2} \quad (\text{AISI S100 Eq. J4.3.1-5})$$

For $1.0 < t_2/t_1 < 2.5$, P_{nf} shall be calculated by linear interpolation between the above two cases.

[End of Extraction]

P_{nf} or P_{nfs} shall not exceed P_{nss} , where P_{nss} is the *nominal shear breaking strength [resistance]* of the screw as reported by the manufacturer or determined by independent laboratory testing in accordance with AISI S904.

User Note:

Although t_2 at supports rarely controls the *resistance*, AISI S100 Eqs. J4.3.1-1 through J4.3.1-5 should be investigated, particularly for cold-formed steel supports. AISI S100 Section J4.3.1 is also applicable in Section D1.2.5. Each screw *limit state* should be checked at *side-lap connections*.

D1.1.3 Power-Actuated Fasteners Into Steel Supports

The *connection nominal shear strength [resistance]* per *power-actuated fastener* shall be established by tests in accordance with Section D1.1.5.

Nominal shear strength [resistance] of a *support connection*, P_{nf} or P_{nfs} , shall not exceed P_{npa} where P_{npa} is the *nominal shear breaking strength [resistance]* of the *power-actuated fastener* as reported by the manufacturer or determined by independent laboratory testing.

User Note:

Within the *thickness* limits of Chapter D, *nominal shear breaking strength [resistance]*, P_{npa} , is unlikely to control for *fluted panels*. However, P_{npa} might control for *cellular deck*. *Cellular deck* is discussed in Section D1.5.

D1.1.4 Fasteners Into Wood Supports

D1.1.4.1 Safety Factors and Resistance Factors

The following *safety* and *resistance factors* shall be used to determine the *available shear strength* [*factored resistance*] per unit length of *diaphragm* systems with fasteners into wood supports in accordance with Section C2:

$$\begin{aligned}\Omega &= 3.00 && ASD \\ \phi &= 0.55 && LRFD \\ &= 0.50 && LSD\end{aligned}$$

D1.1.4.2 Screw or Nail Connection Strength Through Bottom Flat and Into Support

Where a wood screw or nail is driven through the *panel's* bottom flat and into a wood support, the *nominal connection shear strength* [*resistance*], P_{nf} and P_{nfs} , shall be determined as follows:

- (a) Wood screw *connection* is in accordance with Eq. D1.1.4.2-1 or Eq. D1.1.4.2-2, as applicable, and
- (b) Nail *connection* is in accordance with Eq. D1.1.4.2-3 or Eq. D1.1.4.2-4, as applicable.

Wood screws shall have a minimum penetration of $4d$ into wood. Nails shall have a minimum penetration into wood of $1/3$ of the required penetration for full strength as shown in Table D1.1.4.2-2. The spacing for full strength and minimum fastener spacing, end distance and edge distance shall be determined in accordance with AISI S100 Sections J4.1 and J4.2 for steel and AWC NDS for wood.

Screw Strength:

For $4d \leq h_s < 7d$

$$P_{nf} = \text{Minimum} \left(\frac{h_s}{7d} P_{nfw}, P_{nfw_s}, P_{nss} \right) \quad (\text{Eq. D1.1.4.2-1})$$

For $h_s \geq 7d$

$$P_{nf} = \text{Minimum}(P_{nfw}, P_{nfw_s}, P_{nss}) \quad (\text{Eq. D1.1.4.2-2})$$

where

d = Nominal diameter of screw fastener

h_s = Threaded length of screw, including the tapered tip that is penetrated into the wood support

P_{nf} = *Nominal shear strength* [*resistance*] of *connection* limited by *bearing* of the screw or nail against either the wood support or *panel*, and modified in accordance with penetration

P_{nfw_s} = *Nominal shear strength* [*resistance*] of wood support connection for fully penetrated screw or nail controlled by *bearing* against the *panel* as defined in Table D1.1.4.2-1

P_{nfw} = *Nominal shear strength* [*resistance*] of fully penetrated wood support connection controlled by *bearing* against the wood as defined in Table D1.1.4.2-1

P_{nss} = *Nominal shear breaking strength* [*resistance*] of screw or nail, as applicable, as reported by the manufacturer or determined by independent laboratory testing

Nail Strength:

For $\frac{h_{sf}}{3} \leq h_{sn} < h_{sf}$

$$P_{nf} = \text{Minimum}\left(\frac{h_{sn}}{h_{sf}} P_{nfw}, P_{nfw}, P_{nss}\right) \quad (\text{Eq. D1.1.4.2-3})$$

For $h_{sn} \geq h_{sf}$

$$P_{nf} = \text{Minimum}(P_{nfw}, P_{nfw}, P_{nss}) \quad (\text{Eq. D1.1.4.2-4})$$

where

h_{sn} = Length of nail that is penetrated into the wood support

h_{sf} = Nail penetration into the wood support as listed in Table D1.1.4.2-2 to develop full *nominal strength [resistance]*, P_{nfw} .

User Note:

AWC NDS 2012 requires a minimum penetration of 4d for lag screws and 6d for wood screws and nails. These requirements should also be considered when determining the minimum length of nail or screw.

Table D1.1.4.2-1
Wood Support Connection Strength

Type		Diameter (d)	P_{nfw}	P_{nfw}
Nail	0.148 in.	0.148 in. (3.76 mm)	$2.2t_1d F_{u1}$	0.673G kips, (2.99G kN)
Screw	No. 9	0.177 in. (4.50 mm)	$2.2 t_1d F_{u1}$	1.00G kips, (4.45G kN)
	No. 10	0.190 in. (4.83 mm)	$2.2 t_1d F_{u1}$	1.12G kips, (4.98G kN)
	No. 12	0.216 in. (5.49 mm)	$2.7 t_1d F_{u1}$	1.43G kips, (6.36kN)
	¼ in. (No. 14)	0.242 in. (6.30 mm)	$2.7 t_1d F_{u1}$	1.97G kips, (8.76G kN)

Note:

- (1) The P_{nfw} values are for dry and seasoned wood.
- (2) 0.148-in. (3.76mm) nails are of four types:
 - (a) 10d pennyweight that are 3 in. (76.2 mm) long and common nail,
 - (b) 12d pennyweight that are 3¼ in. (82.6 mm) long and common nail,
 - (c) 16d pennyweight that are 3¼ in. (82.6 mm) long and sinker nail, and
 - (d) 20d pennyweight that are 4 in. (102 mm) long and box nail.
- (3) Steel wire nail material requirements are in ASTM F1667.
- (4) It is permitted to use the strength of a 0.148 in. (3.76 mm) nail for nails of greater diameter.
- (5) G = Specific gravity of the wood as defined in AWC NDS.
- (6) t_1 = Thickness of member in contact with screw or nail head.
- (7) F_{u1} = Tensile strength of member in contact with screw or nail head or washer.
- (8) For 1/4 in. (No 14) screw, it is permitted to use the nominal diameter of 0.25 in. (6.35 mm).

Table D1.1.4.2-2
Nail Penetration Required for Full Shear Strength

Wood Group	G ¹	Partial Listing of Wood Species in Group (See AWC NDS for more species listings)	Penetration h _{sf}
I	0.65	Ash, Beech, Birch, Hickory, Black and Sugar Maple, Pecan, Red Oak and White Oak	10d
II	0.55	Douglas Fir-Larch, Southern Pine, and Sweet Gum	11d
III	0.45	Douglas Fir-South, Hem-Fir, Eastern and Sitka Spruce, Yellow Poplar, and Pines (Lodgepole, Northern, Ponderosa, Red, and Sugar)	13d
IV	0.35	Northern White and Western Cedars, Balsam Fir, Eastern White Pine, Engelmann Spruce, and White Woods	14d

Note:

- ¹ The listed G is representative of the specific gravity within the group; more precise listing is contained in AWC NDS.

For fasteners that are not included in Table D1.1.4.2-1, the *available shear strength [factored resistance]* for *connections* shall be determined by tests in accordance with Section D1.1.5. In lieu of Section D1.1.5, it is permitted to use AWC NDS to determine the *nominal connection shear strength [resistance]* per fastener provided the *connection safety factor* is less than or equal to 3.50 in AWC NDS or *the resistance factor* is greater than or equal to 0.45.

D1.1.4.3 Screw or Nail Connection Strength Through Top Flat and Into Support

Where the wood screw or nail in a *side-lap connection* is driven through the *panel's top flat* and into a wood support at an *interior panel*, the *connection nominal shear strength [resistance]*, P_{nf} , shall be determined as follows:

- (a) For a wood screw *connection*, P_{nf} is determined in accordance with Eq. D1.1.4.3-1 or Eq. D1.1.4.3-2, as applicable, and
- (b) For a nail *connection*, P_{nf} is determined in accordance with Eq. D1.1.4.3-3 or Eq. D1.1.4.3-4, as applicable.

Where a wood screw or nail is driven through the *panel's top flat* and into an edge, *interior*, or *exterior wood support along the reaction line* at an *edge panel*, the *connection nominal shear strength [resistance]*, P_{nfs} , shall be set equal to 0.0 or a detail shall be provided to allow shear transfer to the *lateral force-resisting system's edge support*.

User Note:

P_{nfs} applies over supports at a *lateral force-resisting system line*. See Section D1.3 for a discussion of required details and the determination of *nominal diaphragm shear strength [resistance]* per unit length, S_{ne} . Where *connections* are through the top flat, the provisions in Section D1.3 are applicable with or without insulation.

Wood screws shall have a minimum penetration of 4d into the wood. Nails shall have a minimum penetration into the wood of 1/3 the required penetration for full strength as shown in Table D1.1.4.2-2. The spacing for full strength and minimum fastener spacing, end distance and edge distance shall be determined in accordance with AISI S100 Sections J4.1 and J4.2 for steel and AWC NDS for wood.

Screw Strength:

For $4d \leq h_s < 7d$

$$P_{nf} = \text{Maximum}\left(\frac{h_s}{7d} P'_{nf}, P_{ns}\right) \quad (\text{Eq. D1.1.4.3-1})$$

For $h_s \geq 7d$

$$P_{nf} = \text{Maximum}(P'_{nf}, P_{ns}) \quad (\text{Eq. D1.1.4.3-2})$$

Nail Strength:

For $\frac{h_{sf}}{3} \leq h_{sn} < h_{sf}$

$$P_{nf} = \frac{h_{sn}}{h_{sf}} P'_{nf} \quad (\text{Eq. D1.1.4.3-3})$$

For $h_{sn} \geq h_{sf}$

$$P_{nf} = P'_{nf} \quad (\text{Eq. D1.1.4.3-4})$$

where

d = Nominal diameter of screw fastener

P_{nf} = Nominal shear strength [resistance] of connection through top flat of panel and at a side-lap

P'_{nf} = Nominal shear strength [resistance] of fully penetrated connection as defined in Table D1.1.4.3-1

P_{ns} = Nominal shear strength [resistance] of screw side-lap connection determined using Section D1.1.2, where t_2 in AISI S100 Eqs. J4.3.1-2 and J4.3.1-3 is the panel thickness not in contact with screw head. It is permitted to exclude AISI S100 Eq. J4.3.1-1.

h_s, h_{sn}, h_{sf} = Values defined in Section D1.1.4.2

P_{nf} shall not exceed P_{nss} . P_{nss} shall be as reported by the manufacturer or determined by independent laboratory testing. The AISI S904 test standard shall be used to determine P_{nss} for screws.

User Note:

P_{nss} is the nominal shear breaking strength [resistance] of the screw or nail.

The screw or nail is fastened into the support, which inhibits tilting, and the impact of fixity and tilting resistance is in Table D1.1.4.3-1.

For fasteners through interior top flats and into supports, as illustrated in Figure D1.1.4.3-1, $P_{nf} = 0.0$.

Table D1.1.4.3-1
Nominal Connection Shear Strength of Fastener
With Full Penetration

Type	Diameter	P'_{nf} kip (kN)	
		t_1 in.	t_1 mm
Nail	0.148 in. (3.76 mm)	$17.3 t_1$	$3.03 t_1$
Screw	No. 9, 0.177 in. (4.50 mm)	$31.8 t_1$	$5.57 t_1$
	No. 10, 0.190 in. (4.83 mm)	$33.5 t_1$	$5.87 t_1$

Note:

t_1 = Design *thickness* of thinner element of *panel* at the *side-lap*, in. (mm)

For screws or nails that are not included in Table D1.1.4.3-1, the *nominal connection shear strength [resistance]* shall be determined by tests in accordance with Section D1.1.5. If screws having diameter greater than Table D1.1.4.3-1 are installed at a *side-lap*, it is permitted to use the P'_{nf} value for the No. 10 screw in Table D1.1.4.3-1 provided the required penetration and spacing are based on the greater screw diameter and *nominal connection strength [resistance]* is determined in accordance with Eq. D1.1.4.3-1 or D1.1.4.3-2 with P_{ns} based on the greater diameter screw. If nails having diameter greater than 0.148 in. (3.76 mm) are installed at a *side-lap*, it is permitted to use the P'_{nf} value in Table D1.1.4.3-1 for the 0.148 in. (3.76 mm) nail provided the required penetration and spacing are based on the greater nail diameter and *nominal connection strength [resistance]* is determined in accordance with Eq. D1.1.4.3-3 or Eq. D1.1.4.3-4.

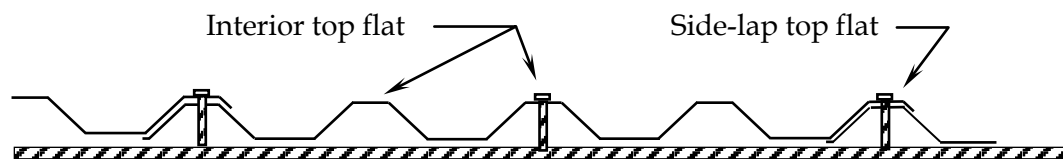

Figure D1.1.4.3-1 Fasteners Through Top Flat

User Note:

The *top overlapping side-lap connection* and *interior top flat connection* described in this section is illustrated in Figure D1.3-4 with insulation. The provisions in Section D1.1.4.3 are applicable with or without insulation.

D1.1.5 Other Connections With Fasteners Into Steel, Wood or Concrete Support

For fasteners in *connections* that are not included in Sections D1.1.1 through D1.1.4 and otherwise conform to Chapter D limits (a) through (d), the equations for *connection nominal fastener strength [resistance]* per fastener, P_{nf} and P_{nfs} , and *safety* and *resistance factors* shall be established by small-scale tests in accordance with Sections E1.1 and E1.2. It is permitted to test *connections* that are included in Section D1.1.1 through D1.1.4 in accordance with Section E1.1 and E1.2 and to use the tested values in design.

Where both lapped end *joints* and single *thickness joints* over *interior supports* exist, P_{nf} *connection strength* shall be based on the single *thickness* shear test.

D1.1.6 Support Connection Strength Controlled by Edge Dimension and Rupture

Multiple lines of support fasteners in an interior flute or at *side-laps* over supports shall conform to the *shear rupture* requirements of AISI S100 Section J6.1 and the *block shear rupture* requirements of AISI S100 Section J6.3, as applicable.

For any single support fastener or an exterior line of support fasteners with an edge dimension parallel with the force, the minimum edge dimension shall conform to Eq. D1.1.6-1 to develop the full *connection nominal shear strength [resistance]* per fastener, P_{nf} .

$$e_{\min} = \frac{P_{nf}}{1.2F_u t} \quad (\text{Eq. D1.1.6-1})$$

where

$$\begin{aligned} e_{\min} &= \text{Clear distance between the end of the material and the edge of weld, fastener,} \\ &\quad \text{or hole to develop full connection strength [resistance]} \\ &= e - \frac{d}{2} \quad \text{for arc spot welds, arc seam welds, screws, or} \\ &\quad \text{power-actuated fasteners} \end{aligned} \quad (\text{Eq. D1.1.6-2})$$

where

e = Distance from the end of the material to the tangent point at the outer edge of the weld, fastener, or hole. Tangent is parallel to the force

If the *required diaphragm shear strength [shear force due to factored loads]* per unit length is less than the *available strength [factored resistance]*, the minimum clear dimension, e'_{\min} , is permitted to be determined using Eq. D1.1.6-3.

$$e'_{\min} = \frac{R\Omega}{S_n} e_{\min} \quad \text{ASD} \quad (\text{Eq. D1.1.6-3a})$$

$$e'_{\min} = \frac{R_u}{\phi S_n} e_{\min} \quad \text{LRFD} \quad (\text{Eq. D1.1.6-3b})$$

$$e'_{\min} = \frac{R_f}{\phi S_n} e_{\min} \quad \text{LSD} \quad (\text{Eq. D1.1.6-3c})$$

where

R , R_u , R_f = *Required diaphragm shear strength [shear force due to factored loads]* per unit length for ASD, LRFD and LSD, respectively. See Section C2 for definitions.

User Note:

As shown in Eqs. D1-1 and D1-2, S_n is proportional to P_{nf} . AISI S100 Section J6.1 indicates that the *nominal shear strength [resistance]* per connection controlled by edge dimension is proportional to e'_{\min} . Eqs. D1.1.6-1 and D1.1.6-3 are consistent with AISI S100 Eqs. J6.1-1 and J6.1-2.

D1.2 Side-Lap Connection Shear Strength [Resistance] in Fluted Deck or Panel, P_{ns}

The *nominal shear strength [resistance]* of a *side-lap connection* per fastener, P_{ns} , shall be calculated in accordance with (a) or determined by tests in accordance with (b).

(a) *Connection Shear Strength [Resistance]* Determined by Calculation

The *nominal shear strength [resistance]* of connections shall be determined in accordance with Sections D1.2.1 through D1.2.6, as applicable. The design values of F_y and F_u used in these

sections shall be modified in accordance with AISI S100 Sections A3.1.2 and A3.1.3 for steels not conforming to AISI S100 Section A3.1.1 unless noted otherwise.

(b) *Connection Shear Strength [Resistance] Determined by Test*

Tests shall be performed to determine the *nominal connection shear strength [resistance]* in accordance with Section D1.2.7.

D1.2.1 Arc Spot Welds

The *side-lap connection nominal shear strength [resistance]*, P_{ns} , of arc spot welds shall be calculated in accordance with AISI S100 Section J2.2.2.2. The minimum center-to-center arc spot weld spacing shall be $2.75d$.

The following section is extracted from AISI S100 with two revisions:

- (1) The *safety and resistance factors* and the design methods in AISI S100 Sections J2.2.2.2 shall not apply.
- (2) The *safety and resistance factors* shall be determined in accordance with Table B-1 and the design methods shall be as listed in Section C2.

[Beginning of Extraction]

AISI S100 J2.2.2.2 Shear Strength for Sheet-to-Sheet Connections

The *nominal shear strength [resistance]*, P_{nv} , for each weld between two sheets of equal *thickness* shall be determined in accordance with AISI S100 Eq. J2.2.2.2-1.

$$P_{nv} = 1.65td_aF_u \quad (\text{AISI S100 Eq. J2.2.2.2-1})$$

where

P_{nv} = *Nominal shear strength [resistance]* of sheet-to-sheet connection

t = *Base steel thickness* (exclusive of coatings) of single welded sheet

d_a = *Average diameter of arc spot weld at mid-thickness* of t . See AISI S100 Figure J2.2.2.2-1 for diameter definitions

$$= (d - t) \quad (\text{AISI S100 Eq. J2.2.2.2-2})$$

where

d = *Visible diameter of the outer surface of arc spot weld*

F_u = *Tensile strength* of sheet as determined in accordance with AISI S100 Sections A3.1 or A3.2

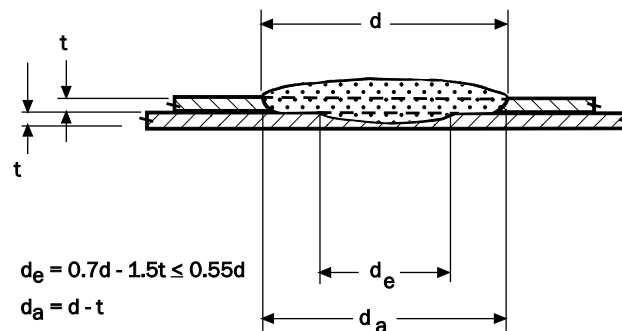

AISI S100 Figure J2.2.2.2-1 Arc Spot Weld – Sheet-to-Sheet

In addition, the following limits shall apply:

- (1) $F_u \leq 59 \text{ ksi (407 MPa or 4150 kg/cm}^2\text{)}$
- (2) $F_{xx} > F_u$
- (3) $0.028 \text{ in. (0.711 mm)} \leq t \leq 0.0635 \text{ in. (1.61 mm)}$

See Section J2.2.2.1 for definition of F_{xx} .

[End of Extraction]

Weld washers shall not be used to join *deck* elements along *side-laps* and between supports.

User Note:

t is the total of sheet *thickness(es)* above the plane of maximum shear transfer. Since the plane is normally between the two sheets, t equals the *thickness* of one sheet.

D1.2.2 Fillet Welds Subject to Longitudinal Shear

The *connection nominal shear strength [resistance]* shall be determined in accordance with Eq. D1.2.2-1 or Eq. D1.2.2-2, as applicable. The lesser product, tF_u , shall be used to determine P_{ns} if the sheets vary at the *connection*.

For $L_w/t < 25$,

$$P_{ns} = \left(1 - 0.01 \frac{L_w}{t}\right) L_w t F_u \quad (\text{Eq. D1.2.2-1})$$

For $L_w/t \geq 25$

$$P_{ns} = 0.75 L_w t F_u \quad (\text{Eq. D1.2.2-2})$$

where

L_w = Length of fillet weld

t = Base steel *thickness* of thinner steel element at the *side-lap* weld

F_u = *Tensile strength* of sheet as determined in accordance with AISI S100 Section A3.1 or A3.2, for element corresponding to the *thickness*, t

The minimum center-to-center fillet weld spacing shall be $1.4 L_w$.

D1.2.3 Flare Groove Welds Subject to Longitudinal Shear

The *connection nominal shear strength [resistance]* of flare groove welds shall be determined in accordance with Eq. D1.2.3-1. The lesser product, tF_u , shall be used to determine P_{ns} if the sheets vary at the *connection*.

$$P_{ns} = 0.75 L_w t F_u \quad (\text{Eq. D1.2.3-1})$$

where

L_w = Length of groove weld

Other parameters are defined in Section D1.2.2.

The minimum center-to-center flare groove weld spacing shall be $1.15 L_w$.

D1.2.4 Top Arc Seam Side-Lap Welds Subject to Longitudinal Shear

Eqs. D1.2.4-1 and D1.2.4-2 are applicable within the following limits for steel conforming to Section D1.2 (a) and AISI S100 Section A3:

- (a) $F_{xx} \geq 60$ ksi (415MPa),
- (b) $h_{st} \leq 1.25$ in. (31.8 mm),
- (c) $L_w = 1.00$ in. (25.4 mm) through 2.50 in. (63.5 mm), and
- (d) $t = 0.028$ in. (0.711 mm) through 0.064 in. (1.63 mm).

where

F_{xx} = Tensile strength of electrode classification

h_{st} = Nominal seam height measured to the top of the seam prior to welding. See Figure D1.2.4-1

L_w = Length of top arc seam side-lap weld. See Figure D1.2.4-1

t = Base steel thickness of thinner steel element at the side-lap weld

The nominal connection shear strength [resistance] of top arc seam side-lap welds shall be determined in accordance with Eq. D1.2.4-1. The length of weld, L_w , shall be specified as

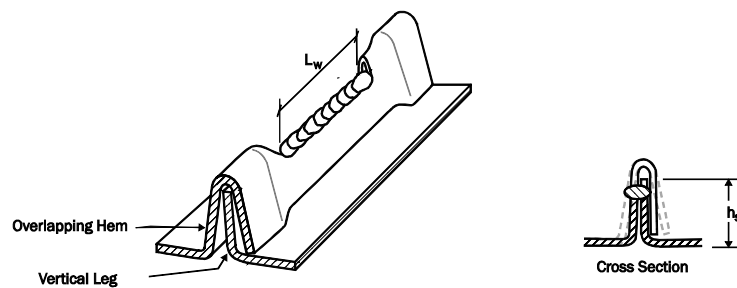

(a) Vertical Leg and Overlapping Hem Joint

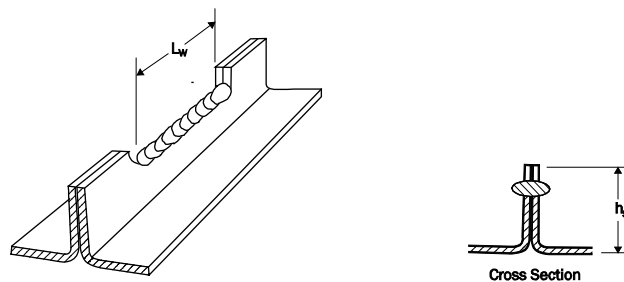

(b) Back-to-Back Vertical Leg Joint

Figure D1.2.4-1 Top Arc Seam Side-Lap Weld

the minimum length of fused weld along each contributing element's thickness at the shear transfer plane of the weld.

$$P_{ns} = \left(4 \frac{F_u}{F_y} - 1.52 \right) L_w t F_u \left(\frac{t}{L_w} \right)^{0.33} \quad (\text{Eq. D1.2.4-1})$$

It is permitted to exclude the connection design reduction specified in AISI S100 Sections

A3.1.2, A3.1.3(b) and A3.1.3(c) for *top arc seam side-lap welds*. The minimum *top arc seam side-lap weld* spacing, s , shall be determined in accordance with Eq. D1.2.4-2. The minimum *top arc seam side-lap weld* end distance between the end of the sheet and the center line of the weld shall be $s/2$.

$$s = \left(6.67 \frac{F_u}{F_y} - 2.53 \right) L_w \left(\frac{t}{L_w} \right)^{0.33} \quad (\text{Eq. D1.2.4-2})$$

where

F_y = Yield stress of specified steel corresponding to the *thickness*, t

F_u = Tensile strength of sheet as determined in accordance with AISI S100 Section A3.1 or A3.2 corresponding to the *thickness*, t

s = Minimum center-to-center spacing of *top arc seam side-lap weld*

Vertical legs in either hem *joints* or vertical-to-vertical *joints* shall fit snugly. In hem *joints*, the hem shall be crimped onto the vertical leg and the crimp length shall be longer than the specified weld length, L_w . Burn through at either one or both ends of the hem is permissible.

D1.2.5 Side-Lap Screw Connections

The *side-lap connection nominal shear strength [resistance]*, P_{ns} , per screw shall be determined in accordance with Section D1.1.2.

User Note:

In AISI S100 Eq. J4.3.1-1 through AISI S100 Eq. J4.3.1-5, t_2 is the fluted *deck* or *panel thickness* not in contact with the screw head.

D1.2.6 Non-Piercing Button Punch Side-Lap Connections

For fluted *panel* or *deck* less than or equal to 3 in. (76.2 mm) in depth, the *nominal shear strength [resistance]*, P_{ns} , of a non-piercing button punch *side-lap connection* shall be:

$$P_{ns} = 0.10 \text{ kips (0.45 kN)}$$

For fluted *panel* or *deck* greater than 3 in. (76.2 mm) in depth or *cellular deck* as described in Section D1.5, the *nominal shear strength [resistance]*, P_{ns} , of a non-piercing button punch *side-lap connection* shall be ignored, i.e.:

$$P_{ns} = 0.00 \text{ kips (0.00 kN)}$$

D1.2.7 Other Side-Lap Connections

For *side-lap connections* that are not included in Sections D1.2.1 through D1.2.6 and for applications that conform to Chapter D limits (a) through (d), the equation for *connection nominal fastener shear strength [resistance]* per fastener, P_{ns} , and *safety and resistance factors* shall be established by small-scale tests in accordance with Section E1.1 and Section E1.2. It is permitted to test *connections* that are included in Section D1.2.1 through D1.2.6 in accordance with Sections E1.1 and E1.2.

User Note:

Proprietary crimped or mechanically formed *connection* shear strengths are determined in accordance with this section.

D1.3 Diaphragm Shear Strength per Unit Length Controlled by Support Connection Strength Through Insulation, S_{nf}

The following limits shall be met for support connections through insulation:

- (a) 0.50 in. (12 mm) \leq *panel* depth \leq 4 in. (102 mm),
- (b) 0.014 in. (0.356 mm) \leq base steel *thickness* of *panel* \leq 0.075 in. (1.91 mm),
- (c) 33 ksi (230 MPa) \leq specified F_y of *panel* \leq 80 ksi (550 MPa),
45 ksi (310 MPa) \leq specified F_u of *panel* \leq 82 ksi (565 MPa),
- (d) Support types are steel or wood,
- (e) Insulation types are fiberglass with a nominal thickness not exceeding 6 in. (15.2 mm) (R-19), or polyisocyanurate or polystyrene boards with a nominal thickness not exceeding 3 1/4 in. (82.6 mm), and
- (f) *Deck* or *panel* *pitch* \leq 12 in. (305 mm).

For *diaphragm* systems outside the limits (a) through (f), the *available strength* [*factored resistance*] of the *diaphragm* system shall be determined in accordance with Chapter E.

The *nominal diaphragm shear strength* [*resistance*] per unit length controlled by *nominal connection strength* [*resistance*], S_{nf} , with *connections* at support through insulation shall be the minimum of the *nominal diaphragm strengths* [*resistances*], S_{ni} , S_{nc} , and S_{ne} , determined in accordance with Section D1 as modified below. The *nominal diaphragm shear strength* [*resistance*], S_{nb} , per unit length controlled by *panel buckling* shall be determined in accordance with Section D2.

In using Eqs. D1-1 and D1-2 to determine S_{ni} and S_{nc} , the *connection nominal shear strength* [*resistance*] per fastener, P_{nf} , at *side-laps* over supports, as shown in Figures D1.3-2, D1.3-3 and D1.3-4, shall be determined in accordance with Sections D1.3.1 through D1.3.3, as applicable. For fasteners through the bottom flat at interior flutes, as shown in Figure D1.3-1, or through the top flat at interior flutes, as shown in Figure D1.1.4.3-1, the *connection nominal shear strength* [*resistance*] per fastener shall be ignored, i.e.:

$$P_{nf} = 0.00 \text{ kips (0.00 kN)}$$

The *nominal diaphragm shear strength* [*resistance*] per unit length at *edge panels*, S_{ne} , shall be determined as follows:

- (a) In calculating S_{ni} , S_{nc} and S_{ne} at an *edge panel*, *panel* width, w_e , is the distance from the adjacent *interior panel side-lap* to the reaction line;
- (b) For fasteners through bottom flats over compressed fiberglass insulation where the gap between the edge support and *edge panel* is less than or equal to 3/8 in. (9.53 mm), fastener contributions along the shear reaction transfer-line are determined as follows:
 - (1) P_{nf} and P_{nfs} are determined in accordance with Section D1.1, and
 - (2) α_1 and $\alpha_2 = 1$ in Eq. D1-3;
- (c) Where *diaphragm* shear per unit length flows from one or two sides into the *lateral force-resisting system*, a detail shall be provided to transfer shear directly to the edge support without going through insulation if any one of the following three conditions exists - See the exception given in Item (d):
 - (1) The gap between the edge support and *panel* exceeds 3/8 in. (9.53 mm),
 - (2) Polyisocyanurate or polystyrene boards are used, or

- (3) *Connections* are through the top flats of *panels*; and
 (d) If the *diaphragm* shear force per unit length can be transferred across a reaction line and be resisted by another *lateral force-resisting system*, then in lieu of providing a detail:

$$P_{nfs} = 0.00 \text{ kips (0.00 kN)}$$

User Note:

In normal applications, fiberglass insulation is compressed to a thickness between 1/4 in. (6.35 mm) and 3/8 in. (9.53 mm). Some details have thermal breaks over supports to overcome insulation compression at supports. The sum of a thermal break thickness and the compressed fiberglass thickness should be less than 3-1/4 in. (82.6 mm) to apply Section D1.3. Polyisocyanurate or polystyrene typically is not compressed significantly.

Where *connections* are through top flats, the opposing and stabilizing *side-lap* shear flow is not present at reaction lines. P_{nfs} typically is, therefore, neglected just as P_{nf} is neglected at interior flutes.

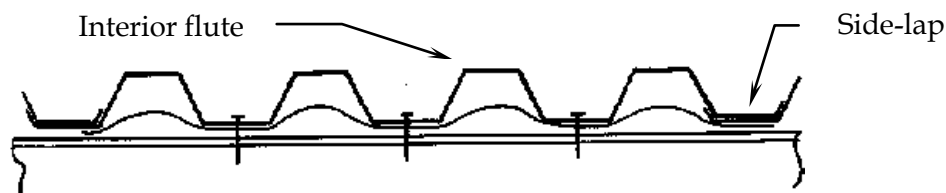

Figure D1.3-1 Fasteners Through Bottom at Interior Flutes Over Insulation

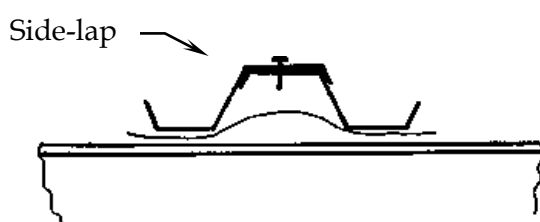

Figure D1.3-2 Fasteners at Lap-Up

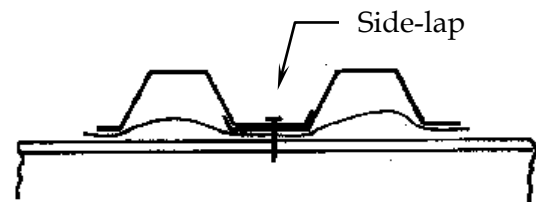

Figure D1.3-3 Fasteners at Lap-Down

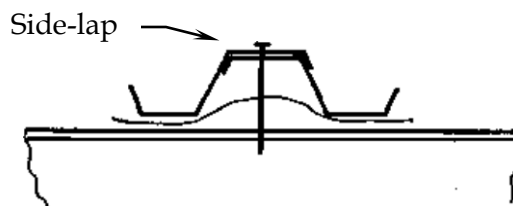

Figure D1.3-4 Lap-Up With Fastener Through Top and Into Support

D1.3.1 Lap-Up Condition at Side-Lap

D1.3.1.1 Lap-Up Condition With Side-Lap Fasteners Not Into Support

The *nominal diaphragm shear strength [resistance]* per unit length, S_{nf} , at a lap-up condition with *side-lap* fasteners through the top flat and not into a support, as shown in Figure D1.3-2, shall be determined in accordance with Eq. D1.3.1.1-1.

$$S_{nf} = \frac{n_s P_{ns}}{L} \quad (\text{Eq. D1.3.1.1-1})$$

where

n_s = Number of *side-lap connections* along a total *panel length*, L , and not into supports

P_{ns} = *Nominal shear strength [resistance]* of a *side-lap (stitch) connection* per fastener. See Section D1.2

L = Total *panel length*

D1.3.1.2 Lap-Up Condition With Side-Lap Fasteners Into Support

The *nominal diaphragm shear strength [resistance]* per unit length, S_{nf} , at a lap-up condition with a side-lap fastener through the top flat and into a support, as shown in Figure D1.3-4, shall be determined in accordance with Section D1 except:

(a) β of Eq. D1-5 is simplified to Eq. D1.3.1.2-1, and

(b) P_{nf} of *connection* at *side-lap* is determined as follows:

(1) $P_{nf} = P_{ns}$ for supports other than wood, and

(2) P_{nf} is determined in accordance with Section D1.1.4.3 for wood supports.

$$\beta = n_s \alpha_s + n_p A_p + 2A \quad (\text{Eq. D1.3.1.2-1})$$

where

A = Number of *exterior support connections* located at the *side-lap* at an *interior panel* or *edge panel's end*. See Figure D1-1

A_p = Number of *interior support connections* located at the *side-lap* at an *interior panel* or *edge panel*. See Figure D1-1

n_s = Number of *side-lap connections* along a total *panel length*, L , and not into supports

$\alpha_s = 1$ for support other than wood

$$= \frac{P_{ns}}{P_{nf}} \text{ for wood support} \quad (\text{Eq. D1.3.1.2-2})$$

where

P_{ns} = *Nominal shear strength [resistance]* of a *side-lap connection* per fastener determined in accordance with Section D1.2

P_{nf} = *Nominal shear strength [resistance]* of a *support connection* per fastener at *side-lap* and into wood support

D1.3.2 Lap-Down Condition at Side-Lap

The *nominal diaphragm shear strength [resistance]* per unit length, S_{nf} , at a lap-down condition with a support fastener through the bottom flat at the *side-lap*, as shown in Figure D1.3-3, shall be determined in accordance with Section D1 with β determined in accordance with Eq. D1.3.1.2-1, and α_s determined by Eq D1.3.2-1:

$$\alpha_s = \frac{P_{ns}}{P_{nf}} \quad (\text{Eq. D1.3.2-1})$$

where

P_{nf} = *Nominal shear strength [resistance]* of a *support connection* per fastener at *side-lap*

and determined in accordance with Section D1.1
 P_{ns} = Nominal shear strength [resistance] of a side-lap connection per fastener determined in accordance with Section D1.2

D1.3.3 Other Support Fasteners Through Insulation

For fasteners that are not listed within Section D1.1 while all other parameters of the diaphragm system conform to Section D1.3, the connection nominal shear strength [resistance] per fastener, P_{nf} , shall be determined in accordance with Section D1.1.5. The tested support thickness contribution and insulation type shall be consistent with the intended use.

The nominal diaphragm shear strength [resistance] per unit length, S_{nf} , shall be determined in accordance with Sections D1.3.1 or D1.3.2, as applicable.

D1.4 Fluted Acoustic Panel With Perforated Elements

Nominal diaphragm shear strength [resistance] per unit length, S_n , shall be determined using Section D1. Where acoustic panel connections are not installed at a perforated zone of the panel, P_{nf} and P_{ns} are permitted to be determined in accordance with Section D1.1 and Section D1.2, as applicable, using the nominal connection strength [resistance] at an unperforated element.

Where acoustic panel connections are installed at a perforated zone of the panel, the connection nominal shear strength [resistance] per fastener, P_{nf} or P_{ns} , shall be determined in accordance with Section D1.1.5 or Section D1.2.7, as applicable.

Where lapped joints at panel ends and single steel thickness joints over interior supports exist along a panel length, L , P_{nf} shall be the nominal shear strength based on the single steel thickness as used in Eqs. D1-1, D1-2, and D1-3.

D1.5 Cellular Deck

Cellular deck nominal diaphragm shear strength [resistance] per unit length, S_n , shall be determined using Section D1 provided the following limitations are met:

- (a) 0.5 in. (12.7 mm) \leq cellular deck depth \leq 7.5 in. (191 mm),
- (b) 0.034 in. (0.864 mm) \leq bottom plate base steel thickness \leq 0.064 in. (1.63 mm),
- (c) 0.034 in. (0.864 mm) \leq top deck base steel thickness \leq 0.064 in. (1.63 mm),
- (d) Support fastener types are welds, screws, or power-actuated fasteners,
- (e) No insulation beneath the cellular deck at the support,
- (f) Fastener edge dimensions satisfy requirements specified in AISI S100, and
- (g) Deck pitch \leq 12 in. (305 mm).

D1.5.1 Safety Factors and Resistance Factors for Cellular Deck

The safety factors and resistance factors shall be in accordance with Table B-1.

D1.5.2 Connection Strength and Design

The following design provisions shall be applicable to combinations of top deck and bottom plate thickness that satisfy Section D1.5:

- (a) The nominal shear strength [resistance] of a support connection per fastener, P_{nf} , at an

interior flute shall be determined in accordance with Section D1.1 using the total *thickness* of both top deck and bottom plate that are penetrated by the fastener above the plane of shear transfer at the support.

- (b) Where a support fastener is installed at the *side-lap*, P_{nf} shall be determined in accordance with Section D1.1 using the *thickness(es)* of the elements above the plane of shear transfer. The weld effective diameter, d_e , of the fused area at the plane of maximum shear transfer shall be based on the total *thickness* penetrated into the support and determined in accordance with AISI S100 Eq. J2.2.2.1-1 in Section D1.1.1.
- (c) Where the design does not allow a support fastener to engage both sections of *deck* at the *side-lap*:
 - (1) Fasteners shall be installed in each *deck* section at the *side-lap*, and
 - (2) Fasteners shall conform to the required edge and end distances in AISI S100 Chapter J to develop the full *nominal shear strength [resistance]*.
- (d) The *nominal shear strength [resistance]* of a *side-lap connection* per fastener, P_{ns} , shall be determined in accordance with Section D1.2 using the *thickness* of the thinner element containing the *side-lap* fastener. Where the *side-lap* is button punched:
 - (1) $P_{ns} = 0.00$, or
 - (2) P_{ns} shall be determined in accordance with Section D1.2.7.

User Note:

The contribution of a button punch is not neglected in the determination of G' . See Section D5.2.5.

D1.6 Standing Seam Panels

For *standing seam panels* that do not conform to the limits (a) through (d) of Chapter D, or for *support connections* that are not defined in Section D1.1, the *nominal diaphragm shear strength [resistance] per unit length*, S_n , and the *diaphragm stiffness*, G' , of *standing seam panels* shall be ignored; i.e.:

- (a) $S_n = 0.00$, and
- (b) $G' = 0.00$.

Alternatively, the *nominal diaphragm shear strength [resistance] per unit length* and *stiffness* shall be determined by tests in accordance with Chapter E. The test support *thickness* and *panel thickness* shall be consistent with the intended use. If fixity is used at one end of the *panel* in design application, the test detail shall include fixity at one end. It is permitted to include backer plates or other stiffening details at the other end if they are part of the system design. The backer plates, other stiffening details, and the *panel* shall not be fastened to that support.

Applications of tests in accordance with Section E1 or E2 shall be limited by the test scope. Extrapolation is not permitted. The *safety* and *resistance factors* shall be determined in accordance with Section E1.2.2 or E2.2, as applicable. The *safety factor* shall be greater than or equal to and the *resistance factor* shall be less than or equal to those determined in accordance with Table B-1.

User Note:

AISI CF97-1, *A Guide for Designing With Standing Seam Roof Panels*, is a design guide for *standing seam panels* under various loading conditions. It defines test procedures to isolate the *strength* and *stiffness* of the *diaphragm* as required to determine the bracing capacity of the roof system.

D1.7 Double-Skinned Panels

The *nominal diaphragm shear strength [resistance]* per unit length, S_n , for *double-skinned panels*, as illustrated in Figure D1.7-1, shall be determined in accordance with Chapter D by neglecting the contribution of the top *panel*. The following conditions shall apply:

- (a) A bottom *panel* is fastened directly to a structural support,
- (b) Sub-girts or sub-purlins are fastened to the bottom *panel* at an elevated plane, and
- (c) A top *panel* is fastened to the sub-girts or sub-purlins.

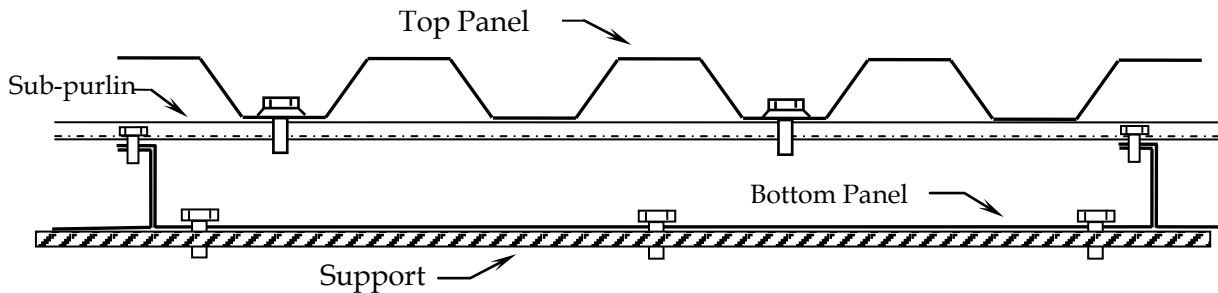

Figure D1.7-1 Double-Skinned Panels

In addition, $\lambda = 1$ in Eq. D1-1, and the calculated *available diaphragm shear strength [factored resistance]* per unit length shall satisfy Eq. D1.7-1:

$$\frac{S_n}{\Omega} \leq \frac{S_{nw}}{\Omega_v} \quad \text{for ASD} \quad (\text{Eq. D1.7-1a})$$

$$\phi S_n \leq \phi_v S_{nw} \quad \text{for LRFD and LSD} \quad (\text{Eq. D1.7-1b})$$

where

Ω = Safety factor for diaphragm system determined in accordance with Table B-1

ϕ = Resistance factor for diaphragm system determined in accordance with Table B-1

S_{nw} = *Nominal shear strength [resistance]* per unit length of the bottom *panel* acting as a *web*

$$= A_w F_v \quad (\text{Eq. D1.7-2})$$

where

A_w = Area per unit width between *webs* of the bottom *panel*

F_v = *Nominal shear stress* determined in accordance with AISI S100, Section G2

Ω_v = 1.60 for ASD

ϕ_v = 0.95 for LRFD

= 0.80 for LSD

If an end closure is detailed to transfer the shear from the top *panel* to the support at *panel* ends and over a *lateral force-resisting system*, the *available shear strength [factored resistance]* per unit length of the *diaphragm* is permitted to include the additive contribution of the top *panel* as determined by test in accordance with Chapter E.

User Note:

Eq. D1.7-1 applies to both perforated and solid bottom *panels*. Perforations can impact the *nominal shear strength [resistance]* per unit length determined using Eq. D1.7-2.

D2 Stability Limit, S_{nb}

D2.1 Fluted Panel

The *nominal diaphragm shear strength [resistance]* per unit length, S_{nb} , controlled by *out-of-plane panel buckling* for either *acoustic* or *non-acoustic* fluted panels shall be calculated using Eq. D2.1-1 for all span applications. See Figure D2.1-1 for details.

$$S_{nb} = \frac{7890}{\alpha L_v^2} \left(\frac{I_{xg}^3 t^3 d}{s} \right)^{0.25} \quad (\text{Eq. D2.1-1})$$

where

S_{nb} = *Nominal diaphragm shear strength [resistance]* per unit length controlled by *panel out-of-plane buckling*, kip/ft (kN/m)

α = Conversion factor for units
 = 1 for U.S. customary units
 = 1879 for SI units

L_v = Span of *panel* between supports with fasteners, ft (m)

I_{xg} = Moment of inertia of fully effective *panel* per unit width, in.⁴/ft (mm⁴/mm)

t = Base steel *thickness* of *panel*, in. (mm)

d = *Panel* corrugation *pitch*, in. (mm)

s = Developed flute width per *pitch*, in. (mm)
 = $2(e + w) + f$

(Eq. D2.1-2)

where

e = One-half the bottom flat width of *panel* measured between points of intercept, in. (mm)

w = *Web* flat width of *panel* measured between points of intercept, in. (mm)

f = Top flat width of *panel* measured between points of intercept, in. (mm)

For fluted *acoustic panels*, the following shall apply:

- The developed flute width, s , is determined in accordance with Eq. D2.1-2 using the modified element lengths in Appendix 1 Section 1.6 by setting $e = e_p$, $w = w_p$, and $f = f_p$,
- The modified *panel* moment of inertia, I_{xg} , is obtained from the manufacturer, and
- Other parameters in Eq. D2.1-1 are not modified.

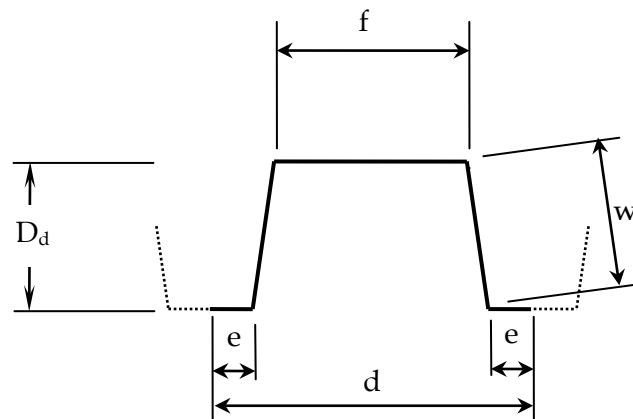

Figure D2.1-1 Panel Configuration

D2.2 Cellular Deck

The *nominal diaphragm shear strength [resistance]* per unit length controlled by *panel out-of-plane buckling*, S_{nb} , for either *cellular deck* or *cellular acoustic deck* shall be calculated using Eq. D2.1-1 for all span applications as modified below:

- (a) I_{xg} = Moment of inertia of *fully effective cellular deck* per unit width, in.⁴/ft (mm⁴/mm), and
- (b) t, s, d = Properties of the top fluted *deck* in *cellular deck*.

The moment of inertia, I_{xg} , shall be modified for perforation in the top or bottom elements, as applicable. The modified I_{xg} is permitted to be obtained from the manufacturer. If the top *deck* is perforated, the top *deck* property, s , shall be modified in accordance with Section D2.1 as specified for *acoustic panels*. Other parameters in Eq. D2.1-1 shall not be modified.

D3 Shear and Uplift Interaction

D3.1 Support Connections

Where a *support connection* is subjected to combined shear and tension, the *nominal shear strength [resistance]* of a *support connection* per fastener, P_{nf} , at *edge* and *interior panels* shall be reduced to the *nominal shear strength [resistance]* of a *support connection* per fastener in the presence of a *tensile load*, P_{nft} . The *nominal diaphragm strengths [resistances]* per unit length, S_{ni} and S_{nc} , shall be calculated in accordance with Section D1 by setting P_{nf} equal to P_{nft} .

Where applicable at edge supports, S_{ne} shall be calculated in accordance with Section D1 by setting P_{nf} equal to P_{nft} in Eq. D1-3. The *nominal shear strength [resistance]*, P_{nfs} , of an *edge support connection* between transverse supports at an *edge panel* is permitted to not be reduced for combined shear and tension.

P_{nft} shall be the smallest interaction value controlled by:

- (a) Pull-over in the *connection*,
- (b) Pull-out in the *connection*, and
- (c) Breaking *strength* of the fastener.

The interaction equations to determine P_{nft} for prequalified *support connections* are listed in Sections D3.1.1 through D3.1.4. It is permitted to establish the interaction equations to determine P_{nft} for prequalified or alternative *connections* by small-scale tests in accordance with Sections E1.1 and E1.2. Where the *connection* strength is determined by tests in accordance with Section D1.1.5 for shear or AISI S100 Section K2.1 for tension, the interaction effect for any or all *limit states* shall be determined by:

- (a) Test in accordance with AISI S905, or
- (b) Defaulting to a linear interaction effect without additional tests.

User Note:

A linear interaction effect is consistent with providing sufficient fasteners to resist each *required strength [effect due to factored loads]* component separately. Eqs. D3.1.2.1-13 and -14, and D3.1.3-1a and variable b are linear interaction effects. The *safety factor* and *resistance factor* in linear interaction equations for a *connection* depend on the source of the *nominal tension strength [resistance]* for each *limit state*.

D3.1.1 Arc Spot Welds

P_{nft} shall be determined in accordance with Eq. D3.1.1-1 or Eq. D3.1.1-2, as applicable, for *ASD*; and in accordance with Eq. D3.1.1-3 or Eq. D3.1.1-4, as applicable, for *LRFD* and *LSD*.

For *ASD*

$$\text{If } \left(\frac{\Omega_t T}{P_{nt}} \right)^{1.5} \leq 0.15$$

$$P_{nft} = P_{nf} \quad (\text{Eq. D3.1.1-1})$$

$$\text{If } \left(\frac{\Omega_t T}{P_{nt}} \right)^{1.5} > 0.15$$

$$\left(\frac{P_{nft}}{P_{nf}} \right)^{1.5} + \left(\frac{\Omega_t T}{P_{nt}} \right)^{1.5} = 1 \quad (\text{Eq. D3.1.1-2})$$

where

T = Required allowable tensile strength of a support connection per weld determined for loads and load combinations in accordance with Section A3

P_{nf} = Nominal shear strength [resistance] of a support connection per weld in the absence of a tensile load, and determined in accordance with Section D1.1.1

P_{nft} = Nominal shear strength [resistance] of a support connection per weld in the presence of a tensile load

P_{nt} = Nominal tension strength [resistance] of a support connection per weld determined using AISI S100 Section J2.2.3

Ω_t = Safety factor for a connection subjected to tension
= 2.5 for a weld in deck applications

For *LRFD* and *LSD*

$$\text{If } \left(\frac{\bar{T}}{\phi_t P_{nt}} \right)^{1.5} \leq 0.15,$$

$$P_{nft} = P_{nf} \quad (\text{Eq. D3.1.1-3})$$

$$\text{If } \left(\frac{\bar{T}}{\phi_t P_{nt}} \right)^{1.5} > 0.15,$$

$$\left(\frac{P_{nft}}{P_{nf}} \right)^{1.5} + \left(\frac{\bar{T}}{\phi_t P_{nt}} \right)^{1.5} = 1 \quad (\text{Eq. D3.1.1-4})$$

where

\bar{T} = Required tensile strength [tensile force due to factored loads] per weld determined for loads and load combinations in accordance with Section A3 (See AISI S100 Section J2.2.4)

= T_u for *LRFD*

= T_f for *LSD*

ϕ_t = Resistance factor for a connection subjected to tension
 = 0.60 for a weld in deck applications in LRFD
 = 0.50 for a weld in deck applications in LSD

D3.1.2 Screws

D3.1.2.1 Screws Into Steel Supports

P_{nft} shall be the smallest value controlled by cases (a), (b), and (c), as applicable:

(a) Interaction of Shear and Pull-Over

P_{nft} shall be the smaller value determined using Eq. D3.1.2.1-1 and Eq. D3.1.2.1-2 for ASD, or Eq. D3.1.2.1-3 and Eq. D3.1.2.1-4 for LRFD and LSD provided that the limits of AISI S100 Section J4.5.1 are met.

For ASD

$$P_{nft} = P_{nf} \quad (\text{Eq. D3.1.2.1-1})$$

$$\left(\frac{P_{nft}}{\Omega_d P_{nf}} \right) + \left(\frac{0.71T}{P_{nov}} \right) = \frac{1.1}{\Omega} \quad (\text{Eq. D3.1.2.1-2})$$

where

P_{nft} = Nominal shear strength [resistance] of a support connection per screw in the presence of a tensile load

P_{nf} = Nominal shear strength [resistance] of a support connection per screw determined in accordance with Section D1.1.2

T = Required allowable tensile strength of a support connection per screw determined for loads and load combinations in accordance with Section A3

P_{nov} = Nominal tension strength [resistance] of a support connection per screw controlled by pull-over and determined in accordance with AISI S100, Section J4.4.2

Ω = Safety factor for a screw connection subjected to combined shear and pull-over interaction
 = 2.35

Ω_d = Safety factor for a diaphragm controlled by connections and determined in accordance with Table B1.1
 = 2.00 for a screw connection subject to wind loads

For LRFD and LSD

$$P_{nft} = P_{nf} \quad (\text{Eq. D3.1.2.1-3})$$

$$\left(\frac{\phi_d P_{nft}}{P_{nf}} \right) + \left(\frac{0.71\bar{T}}{P_{nov}} \right) = 1.1\phi \quad (\text{Eq. D3.1.2.1-4})$$

where

ϕ = Resistance factor for a screw connection subjected to combined shear and pull-over interaction
 = 0.65 for LRFD
 = 0.55 for LSD

- ϕ_d = Resistance factor for a diaphragm controlled by connections and determined in accordance with Table B1.1
 = 0.80 for a screw connection subject to wind loads in LRFD
 = 0.75 for a screw connection subject to wind loads in LSD
 \bar{T} = Required tensile strength [tensile force due to factored loads] per screw determined for loads and load combinations in accordance with Section A3 (See AISI S100 Section J2.2.4)
 = T_u for LRFD
 = T_f for LSD

User Note:

Anomalies exist at Eq. D3.1.2.1-2 and Eq. D3.1.2.1-4 where \bar{T} approaches 0.00. Refer to the Commentary for more information.

AISI S100 Section J4.5.1 does not include pull-over strength for panels with insulation between the panel and a support, and tests or rational engineering analysis are required to determine pull-over strength. Many panel manufacturers have performed large-scale tests with insulation and may be able to provide the necessary information.

(b) Interaction of Shear and Pull-Out

P_{nft} shall be the smaller value using Eq. D3.1.2.1-5 and Eq. D3.1.2.1-6 for ASD, or Eq. D3.1.2.1-7 and Eq. D3.1.2.1-8 for LRFD and LSD provided that the limits of AISI S100 Section J4.5.2 are met. P_{nf} is determined in accordance with Section D1.1.2.

For ASD

$$P_{nft} = P_{nf} \quad (\text{Eq. D3.1.2.1-5})$$

$$\left(\frac{P_{nft}}{\Omega_d P_{nf}} \right) + \left(\frac{T}{P_{not}} \right) = \frac{1.15}{\Omega} \quad (\text{Eq. D3.1.2.1-6})$$

where

P_{not} = Nominal tension strength [resistance] of a support connection per screw controlled by pull-out determined in accordance with AISI S100, Section J4.4.1

Ω = Safety factor for a screw connection subjected to combined shear and pull-out interaction
 = 2.55

Other parameters are defined in Section D3.1.2.1(a).

For LRFD and LSD

$$P_{nft} = P_{nf} \quad (\text{Eq. D3.1.2.1-7})$$

$$\left(\frac{\phi_d P_{nft}}{P_{nf}} \right) + \left(\frac{\bar{T}}{P_{not}} \right) = 1.15\phi \quad (\text{Eq. D3.1.2.1-8})$$

where

ϕ = Resistance factor for a screw connection subjected to combined shear and pull-out interaction
 = 0.60 for LRFD
 = 0.50 for LSD

Other parameters are defined in Section D3.1.2.1(a).

User Note:

Anomalies exist at Eq. D3.1.2.1-8 where \bar{T} approaches 0.00. Refer to the *Commentary* for more information.

(c) Interaction of Shear and Tension in the Screw

Where P_{nss} controls P_{nf} and P_{nts} controls P_{nt} , P_{nft} shall be the smaller value using Eq. D3.1.2.1-9 and Eq. D3.1.2.1-10 for *ASD*, or Eq. D3.1.2.1-11 and Eq. D3.1.2.1-12 for *LRFD* and *LSD*.

For *ASD*

$$P_{nft} = P_{nf} \quad (\text{Eq. D3.1.2.1-9})$$

$$\frac{P_{nft}}{P_{nf}} + \frac{\Omega_t T}{P_{nts}} = 1.3 \quad (\text{Eq. D3.1.2.1-10})$$

For *LRFD* and *LSD*

$$P_{nft} = P_{nf} \quad (\text{Eq. D3.1.2.1-11})$$

$$\frac{P_{nft}}{P_{nf}} + \frac{\bar{T}}{\phi_t P_{nts}} = 1.3 \quad (\text{Eq. D3.1.2.1-12})$$

where

P_{nss} = Nominal shear breaking strength [resistance] of screw reported by the manufacturer or determined by independent laboratory testing in accordance with AISI S904

P_{nts} = Nominal tensile breaking strength [resistance] of screw reported by the manufacturer or determined by independent laboratory testing in accordance with AISI S904

Ω_t = Safety factor for a connection subjected to tension
= 3.0 for a screw

ϕ_t = Resistance factor for a connection subjected to tension
= 0.50 for a screw in *LRFD*
= 0.40 for a screw in *LSD*

Other parameters are defined in Section D3.1.2.1(a).

Tests shall be performed for conditions outside the limits of Section D3.1.2.1 (a), (b) or (c). Shear or tension tests are permitted for screws in accordance with Section D1.1.5. It is permitted to determine the nominal shear strength [resistance], P_{nft} , using Eqs. D3.1.2.1-13 to D3.1.2.1-15 for *ASD* or Eqs. D3.1.2.1-16 to D3.1.2.1-18 for *LRFD* or *LSD*, as applicable, for connection strengths based on small-scale tests for shear or tension with tension controlled by pull-over, pull-out, or breaking strength.

For *ASD*

$$\frac{P_{nft}}{P_{nf}} + \frac{\Omega_t T}{P_{nov}} = 1 \quad (\text{Eq. D3.1.2.1-13})$$

$$\frac{P_{nft}}{P_{nf}} + \frac{\Omega_t T}{P_{not}} = 1 \quad (\text{Eq. D3.1.2.1-14})$$

$$\frac{P_{nft}}{P_{nf}} + \frac{\Omega_t T}{P_{nts}} = 1 \quad (\text{Eq. D3.1.2.1-15})$$

For *LRFD* and *LSD*

$$\frac{P_{nft}}{P_{nf}} + \frac{\bar{T}}{\phi_t P_{nov}} = 1 \quad (\text{Eq. D3.1.2.1-16})$$

$$\frac{P_{nft}}{P_{nf}} + \frac{\bar{T}}{\phi_t P_{not}} = 1 \quad (\text{Eq. D3.1.2.1-17})$$

$$\frac{P_{nft}}{P_{nf}} + \frac{\bar{T}}{\phi_t P_{nts}} = 1 \quad (\text{Eq. D3.1.2.1-18})$$

where

Ω_t = Safety factor for a connection subjected to tension in accordance with AISI S100 Eq. K2.1.2-2

ϕ_t = Resistance factor for a connection subjected to tension and determined in accordance with Section E1.2.2(b)

It is permitted to use Ω_t and ϕ_t conforming to AISI Section J4.4.2 or J4.4.1 where P_{nov} or P_{not} are determined in accordance with AISI Section J4.4.2 or J4.4.1, respectively.

It is permitted to use Ω_t and ϕ_t determined in accordance with AISI Section J4 for nominal tensile breaking strength, P_{nts} .

D3.1.2.2 Screws Through Bottom Flats Into Wood Supports

P_{nft} shall be the least strength determined in accordance with Sections D3.1.2.1(a) for shear and pull-over, D3.1.2.1(c) for shear and tension in the screw, and Eq. D3.1.2.2-1 for shear and tension controlled by wood. In Section D3.1.2.1(a), P_{nf} shall be determined in accordance with Section D1.1.4.2, where P_{nf} is limited by nominal bearing strength [resistance] against steel, P_{nfws} , and P_{nss} , but not by nominal bearing strength [resistance] against wood, P_{nfw} .

$$\frac{P_{nft}}{P'_{nfw}} = \frac{\cos\theta}{\left[\cos^2\theta \right] + \left[\frac{P'_{nfw}}{P_{nT}} \sin^2\theta \right]} \quad (\text{Eq. D3.1.2.2-1a})$$

$$P_{nft} \leq P'_{nfw} \quad (\text{Eq. D3.1.2.2-1b})$$

where

$$\theta = \tan^{-1}\left(\frac{T}{V}\right) \quad \text{for ASD} \quad (\text{Eq. D3.1.2.2-2a})$$

$$\theta = \tan^{-1}\left(\frac{\bar{T}}{\bar{V}}\right) \quad \text{for LRFD and LSD} \quad (\text{Eq. D3.1.2.2-2b})$$

$$V \leq \frac{P_{nft}}{\Omega} \quad \text{for ASD} \quad (\text{Eq. D3.1.2.2-3a})$$

$$\bar{V} \leq \phi P_{nft} \quad \text{for LRFD and LSD} \quad (\text{Eq. D3.1.2.2-3b})$$

$$\frac{P_{\text{nft}}}{P'_{\text{nfw}}} \geq \left(\frac{\Omega S_{\text{req}}}{S_{\text{nf}}} \right) \quad \text{for ASD} \quad (\text{Eq. D3.1.2.2-4a})$$

$$\frac{P_{\text{nft}}}{P'_{\text{nfw}}} \geq \left(\frac{S_{\text{req}}}{\phi S_{\text{nf}}} \right) \quad \text{for LRFD and LSD} \quad (\text{Eq. D3.1.2.2-4b})$$

P_{nf} = Nominal shear strength [resistance] of a support connection per screw in the absence of a tensile load

P_{nft} = Nominal shear strength [resistance] of a support connection per screw in the presence of a tensile load

P'_{nfw} = Nominal shear strength [resistance] of a support connection per screw controlled by bearing against the wood and modified for wood penetration

$$= \frac{h_s}{7d} P_{\text{nfw}} \quad \text{For } 4d \leq h_s < 7d \quad (\text{Eq. D3.1.2.2-5})$$

$$= P_{\text{nfw}} \quad \text{For } h_s \geq 7d \quad (\text{Eq. D3.1.2.2-6})$$

P_{nfw} = Nominal shear strength [resistance] of fully penetrated wood support connection controlled by bearing against wood determined in accordance with Table D1.1.4.2-1

P_{nT} = Nominal pull-out strength [resistance] per wood support screw in the absence of a shear load, kips (kN)

$$= 6.16\alpha G^2 d h_s \quad (\text{Eq. D3.1.2.2-7})$$

where

G = Specific gravity of wood defined in Section D1.1.4.2

h_s = Threaded length of screw, including the tapered tip that is penetrated into wood support, in. (mm)

d = Nominal diameter of screw, in. (mm)

α = Conversion factor for units

= 1 for U.S. customary unit

= 0.0069 for SI unit

S_{req} = Required diaphragm shear strength [shear force due to factored load] per unit length determined for load and load combinations in accordance with Section A3

T = Required allowable tensile strength of a support connection per screw determined for ASD loads and load combinations in accordance with Section A3

\bar{T} = Required tensile strength [tensile force due to factored loads] of a support connection per screw determined for LRFD or LSD loads and load combinations in accordance with Section A3

= T_u for LRFD

= T_f for LSD

V = Required allowable shear strength of a support connection per screw determined by ASD load and load combinations in accordance with Section A3

\bar{V} = Required shear strength [shear force due to factored loads] of a support connection per screw determined for LRFD or LSD load and load combinations in accordance with Section A3

$$\begin{aligned}
 &= V_u \text{ for LRFD} \\
 &= V_f \text{ for LSD} \\
 \Omega &= 3.00 \text{ for ASD} \\
 \phi &= 0.55 \text{ for LRFD} \\
 &= 0.50 \text{ for LSD}
 \end{aligned}$$

User Note:

In Eq. D3.1.2.2-7, h_s is not limited to 7d.

D3.1.3 Power-Actuated Fasteners

The shear and uplift (tension) *connection* interaction shall be established by small-scale tests. The *safety factor* and *resistance factor* of the interaction equation shall be determined in accordance with Section E1.2.2. In lieu of interaction testing, P_{nft} is permitted to be determined using Eq. D3.1.3-1.

For ASD

$$\frac{P_{nft}}{P_{nf}} + \frac{T}{\min\left(\frac{P_{nov}}{\Omega_{tov}}, \frac{P_{not}}{\Omega_{tot}}\right)} = 1 \quad (\text{Eq. D3.1.3-1a})$$

For LRFD and LSD

$$\frac{P_{nft}}{P_{nf}} + \frac{\bar{T}}{\min(\phi_{tov}P_{nov}, \phi_{tot}P_{not})} = 1 \quad (\text{Eq. D3.1.3-1b})$$

where

P_{nf} = Nominal shear strength [resistance] of a support connection per fastener in the absence of a tensile load

P_{nft} = Nominal shear strength [resistance] of a support connection per fastener in the presence of a tensile load

P_{nov} = Nominal tension strength [resistance] of a support connection per power-actuated fastener controlled by pull-over

P_{not} = Nominal tension strength [resistance] of a support connection per power-actuated fastener controlled by pull-out

T = Required allowable tensile strength of a support connection per fastener determined for ASD loads and load combinations in accordance with Section A3

\bar{T} = Required tensile strength [tensile force due to factored loads] of a support connection per fastener determined for LRFD or LSD loads and load combinations in accordance with Section A3

= T_u for LRFD

= T_f for LSD

Ω_{tov} = Safety factor for a power-actuated fastener controlled by pull-over

= 3.00 (ASD)

Ω_{tot} = Safety factor for a power-actuated fastener controlled by pull-out and determined by test using AISI S100 Section K2.1.2

ϕ_{tov} = Resistance factor for a power-actuated fastener controlled by pull-over

= 0.50 (LRFD)

$$= 0.40 \text{ (LSD)}$$

ϕ_{tot} = Resistance factor for a power-actuated fastener controlled by pull-out and determined by test using AISI S100 Section K2.1.1(b)

User Note:

Power-actuated fastener breaking in tension should be considered in determining P_{not} ; and P_{npa} , the nominal shear breaking strength [resistance], should be considered in determining P_{nf} .

D3.1.4 Nails Through Bottom Flats Into Wood Supports

P_{nft} shall be the least connection shear strength [resistance] per nail determined using Sections D3.1.2.1(a) for shear and pull-over, and D3.1.2.1(c) for shear and tension in the fastener where nail is substituted for screw, and Eq. D3.1.4-1 for shear and tension controlled by wood. In Section D3.1.2.1(a), P_{nf} shall be determined in accordance with Section D1.1.4.2 where P_{nf} is limited by nominal bearing strength [resistance] against steel, P_{nfws} , and P_{nss} , but not by nominal bearing strength [resistance] against wood, P_{nfw} . P_{nov} is determined using the nail head or washer diameter in AISI S100 Eq. J4.4.2-1.

$$\frac{P_{\text{nft}}}{P'_{\text{nfw}}} + \frac{\Omega T}{P_{\text{nT}}} = 1.0 \quad \text{for ASD} \quad (\text{Eq. D3.1.4-1a})$$

$$\frac{P_{\text{nft}}}{P'_{\text{nfw}}} + \frac{\bar{T}}{\phi P_{\text{nT}}} = 1.0 \quad \text{for LRFD and LSD} \quad (\text{Eq. D3.1.4-1b})$$

where

P_{nf} = Nominal shear strength [resistance] of a support connection per nail in the absence of a tensile load and determined in accordance with Section D1.1.4.2

P_{nft} = Nominal shear strength [resistance] of a support connection per nail in the presence of a tensile load

P'_{nfw} = Nominal shear strength [resistance] of a support connection per nail controlled by bearing against wood and modified for wood penetration

$$= \frac{h_{\text{sn}}}{h_{\text{sf}}} P_{\text{nfw}} \quad \text{For } \frac{h_{\text{sf}}}{3} \leq h_{\text{sn}} < h_{\text{sf}} \quad (\text{Eq. D3.1.4-2})$$

$$= P_{\text{nfw}} \quad \text{For } h_{\text{sn}} \geq h_{\text{sf}} \quad (\text{Eq. D3.1.4-3})$$

where

h_{sf} and P_{nfw} = Values defined in Section D1.1.4.2

P_{nT} = Nominal pull-out strength [resistance] per nail in the absence of a shear load, kips (kN)

$$= 2.98\alpha G^{2.5} d h_{\text{sn}} \quad (\text{Eq. D3.1.4-4})$$

where

G = Specific gravity of wood defined in Section D1.1.4.2

h_{sn} = Length of nail that is penetrated into the wood support, in. (mm) and not limited to embedment depth, h_{sf} , as given in Table D1.1.4.2-2

d = Nominal diameter of nail, in. (mm)

α = Conversion factor for units

- γ = 1 for U.S. Customary unit
 = 0.0069 for SI unit
- T = Required allowable tensile strength of a support connection per nail determined for ASD loads and load combinations in accordance with Section A3
- \bar{T} = Required tensile strength [factored tensile force] of a support connection per nail determined for LRFD or LSD loads and load combinations in accordance with Section A3
 = T_u for LRFD
 = T_f for LSD
- Ω = 3.00 for ASD
- ϕ = 0.55 for LRFD
 = 0.50 for LSD

D3.2 Side-Lap Connections

The *side-lap connection nominal shear strength [resistance]* per fastener, P_{ns} , shall be determined in accordance with Section D1.2. It is permitted to not reduce P_{ns} for wind uplift.

D4 Steel Deck Diaphragms With Structural Concrete or Insulating Concrete Fills

The *available diaphragm shear strength [factored resistance]* per unit length with *insulating concrete fill* placed on *deck* or *form deck* on level or sloped roofs, or with *structural concrete* placed on *composite* or *form deck* in floor or roof *diaphragms*, shall be determined in accordance with Sections D4.1 through D4.4, as applicable, provided the following limitations are met:

- (a) 0.5 in. (12.7 mm) \leq steel deck depth \leq 3 in. (76.2 mm),
- (b) 0.014 in. (0.356 mm) \leq base steel deck thickness \leq 0.075 in. (1.91 mm),
- (c) Fastener types include welds with or without washers, screws, and *power-actuated fasteners*,
- (d) 33 ksi (230 MPa) \leq specified F_y of steel deck \leq 80 ksi (550 MPa),
 45 ksi (310 MPa) \leq specified F_u of steel deck \leq 82 ksi (565 MPa),
- (e) *Structural concrete* fill has a minimum thickness of 2 in. (50.8 mm) over top of *form deck* and 2 in. (50.8 mm) over *composite deck*,
- (f) Welded wire reinforcement, steel fibers, synthetic fibers, or some combination are permitted but not required in *structural concrete*,
- (g) The maximum design thickness of fill over the top of *deck* is 6 in. (152 mm),
- (h) For lightweight *insulating concrete* without polystyrene inserts, the minimum thickness over the top of *form deck* is 2.5 in. (63.5 mm),
- (i) *Structural concrete* aggregate conforms to ASTM C33 or ASTM C330, and $f'_c \geq 2500$ psi (17.2 MPa),
- (j) *Insulating concrete* aggregate conforms to ASTM C332, and
- (k) The steel support *thickness* is greater than or equal to 0.10 in. (2.54 mm).

D4.1 Safety Factors and Resistance Factors

The *safety* and *resistance factors* shall be applied for either *structural concrete* or *insulating*

concrete-filled diaphragms to determine the available diaphragm strength [factored resistance].

$$\Omega = 3.25 \quad \text{for ASD}$$

$$\phi = 0.50 \quad \text{for LRFD}$$

$$= 0.45 \quad \text{for LSD}$$

D4.2 Structural Concrete-Filled Diaphragms

The nominal shear strength [resistance] per unit length of diaphragms with structural concrete fill shall be calculated using Eqs. D4.2-1 and D4.2-2.

$$S_n = \frac{\beta P_{nf}}{L} + kbd_c \sqrt{f'_c} \quad (\text{Eq. D4.2-1})$$

$$\frac{\beta P_{nf}}{L} \leq 0.25S_n \quad (\text{Eq. D4.2-2})$$

where

S_n = Nominal shear strength [resistance] per unit length of diaphragm system with structural concrete fill, kip/ft (kN/m)

β = Factor defining connection interaction contribution to diaphragm shear strength per unit length defined in Eq. D1-5

P_{nf} = Nominal shear strength [resistance] of a support connection per fastener defined in Section D1.1, kip (kN)

L = Total panel length, ft (m)

k = Factor for structural concrete strength

$$= \frac{w^{1.5}}{585(10^3)} \quad \text{For U.S. customary units} \quad (\text{Eq. D4.2-3a})$$

$$= \frac{w^{1.5}}{452(10^6)} \quad \text{For SI units} \quad (\text{Eq. D4.2-3b})$$

b = Unit width of diaphragm with structural concrete fill, 12 in. in customary units and 1000 mm in SI units

d_c = Structural concrete thickness above top of deck, in. (mm)

f'_c = Structural concrete compressive strength [resistance], psi (MPa)

w = Structural concrete density, pcf (kg/m³)

User Note:

The shear strength of a steel-headed stud anchor in structural concrete should not be used in Eqs. D4.2-1 and D4.2-2 for P_{nf} . When determining the deck contribution, a steel-headed stud anchor is considered an arc spot weld controlled by bearing of the deck against the weld in accordance with Section D1.1.1, AISI S100 Eqs. J2.2.2.1-2 through J2.2.2.1-4, as applicable.

D4.3 Lightweight Insulating Concrete-Filled Diaphragms

The nominal shear strength [resistance] per unit length of insulating concrete-filled diaphragms controlled by connections at interior panels or edge panels and fill shear strength shall be calculated using Eq. D4.3-1 or Eq. D4.3-2, as applicable. It is permitted to ignore the contribution of insulating concrete fill and to determine the nominal diaphragm shear strength [resistance] per unit length based on the deck alone and controlled by the smallest of Eqs. D1-1,

D1-2 and D1-3.

(a) *Insulating concrete without insulating board in fill:*

$$S_{ni} = \frac{\beta P_{nf}}{L} + \frac{4}{3000} b d_c \sqrt{f'_c} \quad \text{for U.S. customary units} \quad (\text{Eq. D4.3-1a})$$

$$S_{ni} = \frac{\beta P_{nf}}{L} + 1.11 (10)^{-4} b d_c \sqrt{f'_c} \quad \text{for SI units} \quad (\text{Eq. D4.3-1b})$$

where

d_c = *Insulating concrete thickness above top of deck*, in. (mm)

f'_c = *Insulating concrete compressive strength [resistance]*, psi (MPa)

(b) *Insulating concrete with insulating board in fill:*

$$S_{ni} = \frac{\beta P_{nf}}{L} + 0.064 \sqrt{f'_c} \quad \text{for U.S. customary units} \quad (\text{Eq. D4.3-2a})$$

$$S_{ni} = \frac{\beta P_{nf}}{L} + 11.2 \sqrt{f'_c} \quad \text{for SI units} \quad (\text{Eq. D4.3-2b})$$

where

f'_c = *Insulating concrete compressive strength [resistance]*, psi (MPa)

Other parameters and required units are defined in Section D4.2.

Minimum *insulating concrete* thickness above insulating board shall be 2 in. (50.8 mm). Insulating board shall not be installed within 3 ft (0.915 m) of a *lateral force-resisting system* line if the *insulating concrete* fill contributes to the *nominal diaphragm shear strength [resistance]* per unit length.

D4.4 Perimeter Fasteners for Concrete-Filled Diaphragms

Where the contribution of *structural* or *insulating concrete* fill is included in *diaphragm nominal shear strength [resistance]* per unit length, S_n or S_{ni} , the number of perimeter fasteners along the panel length, L , to develop the full *diaphragm shear strength [resistance]* of the system shall be determined in accordance with Eq. D4.4-1, D4.4-2 or D4.4-3, as applicable.

On the perimeter edge parallel to an *edge panel* span:

For $L_v \leq 5$ ft (1.52 m)

$$n_e = \frac{S_n L}{P_{nfs}} \quad (\text{Eq. D4.4-1})$$

For $L_v > 5$ ft (1.52 m)

$$n_e = \text{Max} \left(\frac{S_n L}{P_{nfs}}, \frac{L}{\alpha} \right) \quad (\text{Eq. D4.4-2})$$

For the condition parallel to an *edge panel* span, fasteners shall be equally distributed along the total length that is connected to a *lateral force-resisting system*.

User Note:

Where a *lateral force-resisting system* line has sufficient *stiffness* at an *edge panel* to unload the concrete-filled *diaphragm*, and *diaphragm* shear per unit length flows from two sides, the *required strength [factored resistance]* should be the reaction per unit length at that line.

On the perimeter edge perpendicular to an *interior* or *edge panel* span (i.e., along a

longitudinal chord member):

$$N = \frac{S_n}{P_{nf}} \quad (\text{Eq. D4.4-3})$$

where

L_v = Span of *panel* between supports with fasteners

n_e = Number of edge *support connections* equally distributed along an *edge panel* length with *concrete* fill

S_n = *Nominal shear strength [resistance]* per unit length of *diaphragm* system determined in accordance with Sections D4.2 or D4.3, as applicable
= S_{ni} in Section D4.3

L = Total length of *panel*

P_{nf} = *Nominal shear strength [resistance]* of a *support connection* installed perpendicular to an *interior* or *edge panel* span with *concrete* fill and determined in accordance with Section D1.1 or Section D4.4.1, as applicable

P_{nfs} = *Nominal shear strength [resistance]* of an edge *support connection* installed parallel with an *edge panel* span with *concrete* fill and determined in accordance with Section D1.1 or Section D4.4.1, as applicable

N = Number of *support connections* per unit width at an *interior* or *edge panel's* end

α = Conversion factor for units

= 3.0 for U.S. customary units and L in (ft)

= 0.914 for SI units and L in (m)

Where the contribution of *structural* or *insulating concrete* fill is neglected, the *nominal diaphragm shear strength [resistance]* per unit length shall be determined in accordance with Section D1. The number of required perimeter fasteners, n_e , shall conform to the spacing requirements of Section D1. It is permitted to use Eq. D4.4-1 or D4.4-2, as applicable, to determine n_e .

User Note:

When fill is neglected to resist a given *required strength* [effect due to *factored loads*], the number of required edge support connections, n_e , can be determined from Eq. D1-3, and the *required support connections* per unit width, N , can be determined from Eq. D1-2 by setting the *required strength* [effect due to *factored loads*] equal to or less than the *available strength* [*factored resistance*]. The number of edge fasteners, n_e , can include transverse support fasteners along the edge. P_{nf} may not equal P_{nfs} and n_e can be adjusted using Eq. D1-3 by setting α_1 and $\alpha_2 = 1$.

When *concrete* fill is neglected, a steel-headed stud anchor is equivalent to a large arc spot weld. AISI S100 Eq. J2.2.2.1-1 in Section D1.1.1 can be neglected for a steel-headed stud anchor.

Required strength associated with Eq. D4.4-3 can vary along the *diaphragm* length, L_d .

Where the full *nominal diaphragm shear strength [resistance]* per unit length of the system is not required, it is permitted to reduce the number of fasteners at an *edge panel* in accordance with Eq. D4.4-4. The maximum spacing limit shall apply for $L_v > 5$ ft (1.52 m).

$$n_e = \frac{\Omega_d R L}{P_{nfs}} \quad \text{for ASD} \quad (\text{Eq. D4.4-4a})$$

$$n_e = \frac{R_u L}{\phi_d P_{nfs}} \text{ for LRFD} \quad (\text{Eq. D4.4-4b})$$

$$n_e = \frac{R_f L}{\phi_d P_{nfs}} \text{ for LSD} \quad (\text{Eq. D4.4-4c})$$

Other parameters are defined in Section C2 and the *safety* and *resistance factors* are defined in Section B1.

D4.4.1 Steel-Headed Stud Anchors

Welded steel-headed stud anchors are permitted in *structural concrete* at *edge panels* or perimeters:

- (a) To resist the *required shear strength* [shear force due to *factored loads*], and
- (b) To replace other steel support fasteners with *connection* strength determined in accordance with Section D1.1.

Steel-headed stud anchors shall conform to ANSI/AISC 360 material requirements and shall be welded in accordance with ANSI/AWS D1.1. ANSI/AISC 360 shall be followed to determine steel-headed stud anchor *available shear strength* [*factored resistance*], maximum and minimum spacing, and edge dimension requirements.

Steel-headed stud anchors are not permitted in lightweight *insulating concrete-filled diaphragms* as described in Section D4.3.

User Note:

Proprietary or other mechanical shear connectors are permitted provided the shear connector devices are qualified under the alternative method provisions of *applicable building codes* or the *connection* strength is determined using Section D1.1.5.

D5 Diaphragm Stiffness

D5.1 Stiffness of Fluted Panels

D5.1.1 Fluted Panels Without Perforated Elements

For a *diaphragm* or *wall diaphragm* system with fluted *deck* or *panels*, the *diaphragm stiffness*, G' , shall be calculated in accordance with Eq. D5.1.1-1:

$$G' = \left(\frac{Et}{2(1+\mu)\frac{s}{d} + \gamma_c D_n + C} \right) K \quad \text{kip/in. (kN/m)} \quad (\text{Eq. D5.1.1-1})$$

where

E = Modulus of elasticity of steel
= 29,500 ksi, (203,000 MPa)

t = Base steel *thickness* of *panel*, in. (mm)

K = *Stiffness* factor relating *support* and *side-lap connection flexibilities*
= 1 for steel *panels* with lap-down on steel supports
= S_f/S_s for steel *panels* with lap-up on steel supports
= 0.5 for steel *panels* on wood supports

S_f = *Structural support connection flexibility* determined in accordance with Section

D5.2, in./kip (mm/kN)

S_s = Side-lap connection flexibility determined in accordance with Section D5.2, in./kip (mm/kN)

User Note:

Figure D1.3-3 shows lap-down with insulation but $K = 1$ with or without insulation. Figures D1.3-2 and D1.3-4 show lap-up with insulation but $K = S_f/S_s$ on steel supports with or without insulation.

Ratio, S_f/S_s , equals 0.433 for screws into steel supports and equals 0.5 for screws through bottom flats in wood supports. This can be confirmed using Section D5.2.2 and D5.2.3. S_f/S_s equals 1 for screws through top flats and into wood supports but $K = 0.5$ is used for wood supports with a lap-down or lap-up condition.

μ = Poisson's ratio for steel
= 0.3

d = Panel corrugation pitch. See Figure D2.1-1

s = Developed flute width per pitch. Defined in Section D2.1

D_n = Warping factor considering distortion at panel ends determined in accordance with Appendix 1

γ_c = Support factor for warping determined in accordance with Appendix 1, Table 1.3-1

C = Slip constant considering slippage at side-lap connections and distortion at support connections

$$= \left(\frac{Et}{w} \right) \left(\frac{2L}{2\alpha_3 + n_p\alpha_4 + 2n_s \frac{S_f}{S_s}} \right) S_f \quad (\text{Eq. D5.1.1-2})$$

where

L = Total panel length, in. (m)

α_3 = Measure of exterior support fastener group distribution across a panel width, w , at an interior panel

$$= \frac{\sum x_e}{w} \quad (\text{Eq. D5.1.1-3})$$

x_e = Distance from panel center line to an exterior support structural connection in an interior panel

w = Panel cover width at the interior panel. See Figure D1-1

α_4 = Measure of interior support fastener group distribution across a panel width, w , at an interior panel

$$= \frac{\sum x_p}{w} \quad (\text{Eq. D5.1.1-4})$$

x_p = Distance from panel center line to an interior support structural connection in an interior panel

n_p, n_s = Factors defined in Section D1

User Note:

Each of the three components in the denominator of Eq. D5.1.1-1 is unit-less. Where the prescribed units and the value of E that are listed in this section are used in Eq. D5.1.1-2, C is unit-less. The SI units at Eq. D5.1.1-1 are correct using the prescribed units for the parameters, but a more common unit is kN/mm which can be obtained by dividing the calculated G' by 1000.

S_s and n_s are permitted to be included in Eq. D5.1.1-2 whether the *connection shear strength [resistance]*, P_{ns} , contribution of a *side-lap connection* is included or neglected in the determination of *diaphragm nominal shear strength [resistance]* per unit length, S_n .

Stiffness, G' , is permitted to be determined by tests in accordance with AISI S907.

Stiffness, G' , shall not be reduced due to shear and tension interaction caused by wind uplift.

D5.1.2 Fluted Acoustic Panels With Perforated Elements

For *diaphragm* or *wall diaphragm* with *fluted acoustic panels*, the *diaphragm stiffness, G'* , shall be calculated in accordance with Eq. D5.1.1-1 modified for the perforation effect as follows:

- (a) D_n is determined in accordance with Appendix 1 Section 1.6.
- (b) C is determined using Eq. D5.1.1-2 with *support connection flexibility, S_f* , and *side-lap connection flexibility, S_s* , determined as follows:
 - (1) In accordance with Sections D5.2.1 through D5.2.5, as applicable, for fasteners located in nonperforated zones of an element; or
 - (2) In accordance with Section D5.2.6 for fasteners located in perforated zones of an element.
- (c) s , the developed flute width per *pitch* modified for perforation, is determined using Eq. D5.1.2-1.

$$s = 2e + 2w + f + (E_p + 2W_p + F_p) \left(\frac{1}{k} - 1 \right) \quad (\text{Eq. D5.1.2-1})$$

where

E_p = Width of perforation band in the bottom flat of width, 2e, in. (mm)

W_p = Width of perforation band in the *web* flat of width, w, in. (mm)

F_p = Width of perforation band in the top flat of width, f, in. (mm)

k = Ratio of perforated element stiffness to that of a solid element of the same *thickness, t*, determined in accordance with Appendix 1, Eq. 1.6-5

Other parameters are defined in Section D2.1.

D5.2 Connection Flexibility

The structural *support connection flexibility, S_f* , and *side-lap connection flexibility, S_s* , shall be determined in accordance with Sections D5.2.1 through D5.2.5 or by tests in accordance with Section D5.2.6. It is permitted to determine *connection flexibility* by tests for *connections* listed in Sections D5.2.1 through D5.2.5.

The *connection flexibility* shall not be adjusted for an interaction effect due to the presence of wind uplift.

D5.2.1 Welds Into Steel

D5.2.1.1 Arc Spot or Arc Seam Welds

The *connection flexibilities* of arc spot or arc seam welds shall be determined in accordance with Eq. D5.2.1.1-1 and Eq. D5.2.1.1-2:

$$S_f = \frac{1.15\alpha}{1000\sqrt{t}} \quad (\text{Eq. D5.2.1.1-1})$$

$$S_s = \frac{1.25\alpha}{1000\sqrt{t}} \quad (\text{Eq. D5.2.1.1-2})$$

where

S_f = Structural support connection flexibility of arc spot or arc seam welds, in./kip (mm/kN)

S_s = Side-lap connection flexibility of arc spot or arc seam welds, in./kip (mm/kN)

α = Conversion factor for units
 = 1 for U.S. customary units
 = 28.8 for SI units

t = Total combined base steel *thickness* of *panel* involved in shear transfer above the shear transfer plane, in. (mm)

D5.2.1.2 Top Arc Seam Side-Lap Welds

The *side-lap connection flexibility*, S_s , of *top arc seam side-lap welds* formed between two sheets shall be determined in accordance with Eq. D5.2.1.2-1 for steel conforming to AISI S100 Section A3.

$$S_s = \frac{1.12\alpha}{1000\sqrt{t}} \left(\frac{L_w}{\alpha_5} \right)^{0.25} \quad (\text{Eq. D5.2.1.2-1})$$

where

α_5 = Conversion factor for units
 = 1.5 for U.S. customary units
 = 38 for SI units

L_w = Length of *top arc seam side-lap weld*, in. (mm). See Figure D1.2.4-1 for details

α and t are defined in Section D5.2.1.1.

D5.2.2 Screws Into Steel

The *connection flexibility* of screws into steel shall be determined in accordance with Eq. D5.2.2-1 and Eq. D5.2.2-2.

$$S_f = \frac{1.3\alpha}{1000\sqrt{t}} \quad (\text{Eq. D5.2.2-1})$$

$$S_s = \frac{3.0\alpha}{1000\sqrt{t}} \quad (\text{Eq. D5.2.2-2})$$

where

S_f = Structural support connection flexibility of screws, in./kip (mm/kN)

S_s = Side-lap connection flexibility of screws, in./kip (mm/kN)

α and t are defined in Section D5.2.1.1

Eq. D5.2.2-1 shall be limited to screw size #12 (nominal diameter = 0.216 in. (5.49 mm)) or #14 (nominal diameter = 0.25 in. (6.35 mm)).

The structural support connection flexibility, S_f , shall be determined in accordance with Eq. D5.2.2-2 for screws through top flat and into supports and with or without insulation beneath the panel. The connection with insulation is illustrated in Figure D1.3-4.

User Note:

S_f at supports (Eq. D5.2.2-1) requires that the support is relatively thick and that bearing of the panel against the support screw controls connection strength.

#10 screws are commonly used at side-laps and #8 screws can be, but are rarely used.

D5.2.3 Wood Screws or Nails Into Wood Supports

The connection flexibility, S_f , of wood screws or nails fastened into wood supports with or without insulation beneath the panel shall be determined in accordance with Eq. D5.2.3-1 and Eq. D5.2.3-2, as applicable:

(a) For wood screws or nails fastened through bottom flat and into wood support, as illustrated in Figures D1.3-1 and D1.3-3,

$$S_f = \frac{1.5\alpha}{1000\sqrt{t}} \quad (\text{Eq. D5.2.3-1})$$

(b) For wood screws or nails fastened through top flat and into wood support, as illustrated in Figures D1.1.4.3-1 and D1.3-4,

$$S_f = \frac{3.0\alpha}{1000\sqrt{t}} \quad (\text{Eq. D5.2.3-2})$$

where

S_f = Structural support connection flexibility of fastener into wood supports, in./kip (mm/kN)

α and t are defined in Section D5.2.1.1.

Eqs. D5.2.3-1 and D5.2.3-2 shall be limited to:

- (1) Wood screw sizes #9 (nominal diameter = 0.177 in. (4.50 mm)) through #14 (nominal diameter = 0.25 in. (6.35 mm)), and
- (2) Nail diameters greater than or equal to 0.148 in. (3.76 mm).

D5.2.4 Power-Actuated Fasteners Into Supports

Power-actuated fastener connection flexibilities shall be determined in accordance with Section D5.2.6.

D5.2.5 Non-Piercing Button Punch Fasteners at Steel Panel Side-Laps

The side-lap connection flexibility for non-piercing button punch fasteners in panels shall be determined in accordance with Eq. D5.2.5-1.

$$S_s = \frac{30.0\alpha}{1000\sqrt{t}} \quad (\text{Eq. D5.2.5-1})$$

where

S_s = *Side-lap connection flexibility* of non-piercing button punch, in./kip (mm/kN)

α and t are defined in Section D5.2.1.1.

D5.2.6 Other Fasteners – Flexibility Determined by Tests

Connection flexibilities that are not included in Sections D5.2.1 through D5.2.5 shall be determined by tests in accordance with Sections E1.1 and E1.2. For fasteners located in perforated zones of an element, the test specimen shall contain the perforation pattern.

User Note:

Proprietary crimped or mechanically formed *side-lap connections* are common and acceptable, and their *connection flexibilities* are determined in accordance with this section.

D5.3 Stiffness of Cellular Deck

D5.3.1 Cellular Deck Without Perforations

G' shall be calculated in accordance with Eq. D5.3.1-1:

$$G' = \frac{Et}{A_a + C} \quad (\text{Eq. D5.3.1-1})$$

where

G' = *Diaphragm stiffness* of *cellular deck* without perforations, kip/in. (kN/m)

A_a = Material shear deformation component for *cellular deck*

$$= \frac{2.6 \frac{s}{d}}{1 + \frac{s}{w_d} \frac{t_b}{t}} \quad (\text{Eq. D5.3.1-2})$$

where

s = Developed flute width of top deck in *cellular deck* in accordance with Eq. D2.1-2 in which the variables are defined as follows, in. (mm):

e = Distance from the cell top deck longitudinal fastener to the *web*, in. (mm)

f and w are as defined in Section D2.1, in. (mm).

d = Panel corrugation *pitch* of top fluted *deck* in *cellular deck*, in. (mm)

w_d = Distance measured across the width and between longitudinal rows of fasteners connecting the top *deck* to the bottom plate, in. (mm)

= d where top *deck* to bottom plate fasteners are at the flute center lines, in. (mm)

User Note:

The top deck is attached to the bottom plate by fasteners along the panel's length. The base dimension for cellular deck is w_d , as shown in Figure D5.3.1-1, which can be less than *pitch*, d . *Pitch* d is used in the numerator of Eq. D5.3.1-2.

t_b = Base steel *thickness* of bottom plate in *cellular deck*, in. (mm)

- t = Base steel *thickness* of top deck in cellular deck, in. (mm)
 C = Slip constant considering slippage at *side-lap connections* and distortion at *support connections*; defined by Eq. D5.1.1-2, in which:
 - Structural *support connection flexibility*, S_f , is based on the total thickness of elements above the shear transfer plane, in./kip (mm/kN),
 - Side-lap connection flexibility*, S_s , is based on the thinner element containing the fastener, in./kip (mm/kN), and
 - t is the top deck *thickness*, in. (mm)

Other parameters are as defined in Section D5.1.1. See Figures D2.1-1 and D5.3.1-1 for details.

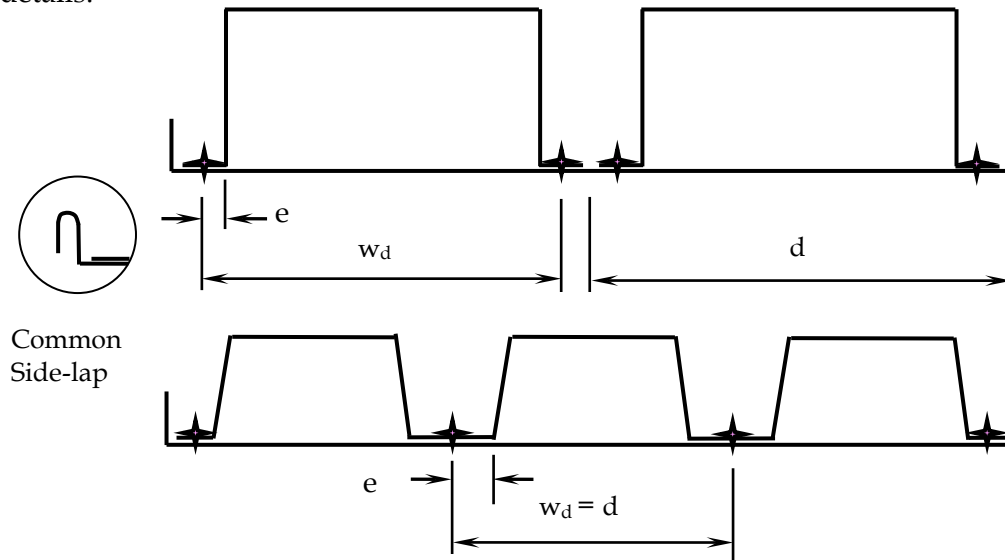

Figure D5.3.1-1 Cellular Deck Types

D5.3.2 Cellular Deck With Perforations

Diaphragm stiffness, G' , of *cellular deck* with perforations shall be calculated in accordance with Eq. D5.3.1-1 with A_a determined in accordance with Eq. D5.3.2-1 and C defined in this section:

$$A_a = \frac{2.6 \frac{s'}{d}}{1 + \frac{s' t_b}{d' t}} \quad (\text{Eq. D5.3.2-1})$$

where

A_a = Material shear deformation component for *cellular deck* with perforations

d' = Equivalent width of *cellular acoustic deck* bottom plate adjusted for perforations and measured between longitudinal rows of fasteners connecting the top deck to the bottom plate, in. (mm)

$$= w_d + w_{dp} \left(\frac{1}{k_b} - 1 \right) \quad (\text{Eq. D5.3.2-2})$$

w_{dp} = Total width of perforation bands in bottom plate width, w_d , in. (mm)

k_b = Ratio of shear stiffness of perforated zone in the bottom plate of *cellular acoustic deck* to a solid zone of the same *thickness*, t_b , and determined in accordance with Appendix 1 Eq. 1.6-5

s' = Developed flute width of top *deck* per width, w_d , in *cellular deck* in accordance with Eq. D5.1.2-1 and modified as follows if perforations are present in the top *deck*:

e = Distance from cell top *deck* longitudinal fastener to *web*, in. (mm)

E_p = Width of perforation band in the bottom flat of width, $2e$, in. (mm)

W_p = Width of perforation band in the *web* flat of width, w , in. (mm)

F_p = Width of perforation band in the top flat of width, f , in. (mm)

k = Ratio of perforated element stiffness to that of a solid element of the same *thickness*, t , determined in accordance with Appendix 1, Eq. 1.6-5

f and w are defined in Section D2.1.

User Note:

By the above definitions, $E_p/2$ is the width of the perforation band in the width, e . s' is s in accordance with Section D5.3.1 when perforations are not present in the top deck.

C = Slip constant considering slippage at *side-lap connections* and distortion at *support connections* determined in accordance with Eq. D5.1.1-2. S_f and S_s are determined in accordance with Section D5.2.6 for fasteners located in perforated zones of an element.

D5.4 Stiffness of Concrete-Filled Diaphragms

D5.4.1 Stiffness of Structural Concrete-Filled Diaphragms

The *diaphragm stiffness*, G' , shall be calculated in accordance with Eq. D5.4.1-1 or Eq. D5.4.1-2 for *diaphragms* with *structural concrete* fill over fluted *deck* or *cellular deck* and that satisfy the limits of applicability given in Section D4:

$$G' = \frac{Et}{2(1 + \mu)\frac{s}{d} + C} + K_3 \quad \text{for fluted deck} \quad (\text{Eq. D5.4.1-1})$$

$$G' = \frac{Et}{A_a + C} + K_3 \quad \text{for cellular deck} \quad (\text{Eq. D5.4.1-2})$$

where

G' = Diaphragm stiffness, kip/in. (kN/m)

E = Modulus of elasticity of steel, ksi (MPa)

t = Base steel thickness of fluted deck, or

= Base steel thickness of top deck in cellular deck, in. (mm)

K_3 = Stiffness contribution of the structural concrete fill

= $3.5d_c(f'_c)^{0.7}$, kip/in. for U.S. customary units (Eq. D5.4.1-3a)

= $786d_c(f'_c)^{0.7}$, kN/m for SI units (Eq. D5.4.1-3b)

d_c = Structural concrete thickness above top of deck, in. (mm)

f'_c = Structural concrete compressive strength, psi (MPa)

A_a = Material shear deformation component for cellular deck determined in accordance with Section D5.3.1

= Material shear deformation component for cellular deck with perforations determined in accordance with Section D5.3.2

Other parameters are defined in Sections D5.1 and D5.3, as applicable.

User Note:

Structural concrete is rarely used over perforated deck, but it may be used with perforated bottom plates in cellular acoustic deck.

D5.4.2 Stiffness of Insulating Concrete-Filled Diaphragms

Diaphragm stiffness, G' , shall be calculated in accordance with Eq. D5.4.2-1 or Eq. D5.4.2-2 for insulating concrete-filled diaphragms that are installed over fluted deck or cellular deck and that satisfy the limits of applicability given in Section D4:

$$G' = \frac{Et}{2(1 + \mu)\frac{s}{d} + C} + K_3 \quad \text{for fluted deck} \quad (\text{Eq. D5.4.2-1})$$

$$G' = \frac{Et}{A_a + C} + K_3 \quad \text{for cellular deck} \quad (\text{Eq. D5.4.2-2})$$

where

K_3 = Stiffness contribution of the insulating concrete fill determined using Eq. D5.4.1-3:

d_c = Insulating concrete thickness above top of deck, in. (mm)

f'_c = Insulating concrete compressive strength, psi (MPa)

Other parameters are defined in Section D5.4.1.

D6 Diaphragm Flexibility

The *flexibility*, F , of the *diaphragm* system shall be calculated in accordance with Eq. D6-1 or determined by test in accordance with Chapter E.

$$F = \frac{1}{G'} \quad (\text{Eq. D6-1})$$

Flexibility, F , shall not be increased due to shear and tension interaction at *connections*.

E. DIAPHRAGM NOMINAL SHEAR STRENGTH PER UNIT LENGTH AND STIFFNESS DETERMINED BY TEST

The *nominal diaphragm shear strength [resistance]* per unit length, and the *diaphragm stiffness or flexibility* are permitted to be determined by tests in accordance with this chapter. Section E1 shall be applicable to any *diaphragm* system and Section E2 shall be applicable to a *single diaphragm system*.

E1 Strength and Stiffness of a Prototype Diaphragm System

Large-scale tests for a *prototype diaphragm system* and small-scale tests for a fastener or *connection* shall be performed at an independent testing laboratory or at a testing laboratory of a manufacturer.

User Note:

The requirements in this *Standard* are consistent with AISI S100 Section K2. Section 1703.1 of the 2012 Edition of the International Building Code requires that testing quality control, data, and test results must also be in conformance with the requirements of the local building official or approval agency. The International Building Code (IBC) is published by International Code Council, Inc., 500 New Jersey Avenue, NW, Washington DC 20001.

E1.1 Test Protocol

Large-scale tests of a *diaphragm* system shall be performed in accordance with AISI S907. Small-scale tests for determining *connection nominal shear strength [resistance]*, *connection flexibility*, *connection nominal tensile strength [resistance]*, and shear and tension interaction of *connections* shall be performed in accordance with AISI S905. Screw shear and tensile breaking *strength* shall be determined in accordance with AISI S904.

Testing in accordance with AISI S907 and AISI S905 is permitted for *diaphragm* systems and *connections* that are connected to non-steel supports. In lieu of AISI S905, the following test methods are permitted to determine the *diaphragm connection strength [resistance]* of *connections* into non-steel supports:

- (a) ASTM D1761 for wood supports, or
- (b) ASTM E1190 or E488 for *structural concrete* supports.

Wood supports shall be seasoned and dry *structural members*.

E1.2 Design Using Test-Based Analytical Equations

This section shall be used to develop, modify, or verify test-based analytical equations and shall apply to each of the following five testing objectives:

- (1) To determine the following *nominal strengths [resistance]* and *flexibilities* of *connections* in a *diaphragm* system that conforms to Chapter D:
 - (i) *Support connection nominal shear strength [resistance]* per fastener, P_{nf} or P_{nfs} , that is not listed in Sections D1.1.1 through D1.1.4,
 - (ii) *Side-lap connection nominal shear strength [resistance]* per fastener, P_{ns} , that is not listed in Sections D1.2.1 through D1.2.6, or

- (iii) *Connection flexibility*, S_f or S_s , per fastener that is not listed in Sections D5.2.1 through D5.2.5.
- (2) To refine the *nominal connection strength [resistance]* or *flexibility* that is listed in Chapter D;
- (3) To establish analytical equations for fluted steel *panels* or *cellular decks*, or *structural* or *insulating concrete-filled decks* that are not within the limits listed in Chapter D for a *diaphragm* system that conforms to Chapter D otherwise;
- (4) To establish analytical equations for strength and *stiffness* of *diaphragm* systems or components based on an existing test-based analytical model other than that of Chapter D; and
- (5) To establish the contribution of an accessory or detail.

Application limits and *safety* and *resistance factors* shall be determined in accordance with the test constructions and results. Extrapolation beyond the established limits is not permitted. The established limits and *safety* and *resistance factors* of an existing *diaphragm* system analytical model shall apply in design as long as the theoretical *nominal strength [resistance]*, S_{ni} theory, from additional tests is based on the existing analytical model. Modifications to application limits and revisions to *safety* and *resistance factors* are permitted if enough tests are performed in accordance with the testing objective.

A basic *diaphragm* system does not include accessories or stiffening details. Accessories or stiffening details that increase strength or *stiffness* relative to the basic system shall be included in the test if increased strength or *stiffness* is the testing objective for design application. However, it is permitted to not include the tested accessories or details in design application regions where the basic system's *nominal strength [resistance]* as determined by calculation or other tests provides the *required strength* or *stiffness*.

The analytical equation calibration shall be based on the base steel *thickness*, mechanical properties, fastener properties and fill material properties that are tested. The *specified minimum* material properties and steel minimum *thickness* shall be used in design applications of the developed analytical equations and shall be further modified as required by AISI S100 Section A3.1.

User Note:

Application limits of analytical systems commonly include material *thickness* and mechanical properties, *connection* types, profile types and dimensions, and rated accessories. See the *Commentary* for a discussion of existing analytical systems.

E1.2.1 Test Assembly Requirements

Small-scale tests to determine *connection strength [resistance]* or *flexibility* are permitted without additional large-scale *diaphragm* tests if the *panel* profile conforms to the limits (a) through (d) of Chapter D, and Sections D1 or D5 are used to establish *diaphragm shear strength [resistance]* per unit length or *stiffness*, respectively. Otherwise, large-scale tests shall be performed. Small-scale tests are permitted in conjunction with large-scale tests.

The essential test parameters for a given testing objective shall be as listed in Table E1.2-1. The number of required tests shall conform to the applicable test standards listed in Section E1.1.

Table E1.2-1
Essential Test Parameters

Testing Objective	Essential Test Parameters
Deck or panel profile	t_{deck} , $F_{y\ deck}$ and $F_{u\ deck}$, profile geometry
Support fastener	t_{deck} , $F_{u\ deck}$, $t_{support}$, $F_{u\ support}$, fastener dimensions and mechanical properties
Side-lap fastener	t_{deck} , $F_{u\ deck}$, fastener dimensions and mechanical properties

Note:

t_{deck} = Thickness of deck or panel

$t_{support}$ = Thickness of support

$F_{y\ deck}$ = Yield stress of deck or panel

$F_{u\ deck}$ = Tensile strength of deck or panel

$F_{u\ support}$ = Tensile strength of support

Tests shall be required to establish the contribution of parameters that are not within the limits of a *diaphragm* analytical model while the model is used to establish *nominal shear strength [resistance]* per unit length, S_n , or *stiffness*, G' . It is permitted to use established *nominal connection strength [resistance]*, P_{nf} , P_{nfs} , or P_{ns} , and *connection flexibility*, S_f or S_s , from alternative analytical models in lieu of small-scale tests, provided the performance of the fasteners in the *diaphragm* system is confirmed by large-scale tests over the application range. It is permitted to use the *nominal shear strength [resistance]* per unit length due to *out-of-plane buckling*, S_{nb} , from an alternative analytical model within its acceptable limits, provided the alternative model's *safety or resistance factor for out-of-plane buckling*, Ω_{db} or ϕ_{db} , is used to determine *available strength [factored resistance]*. All *safety or resistance factors* shall be determined in accordance with Table B1 for tested assemblies.

Small-scale and large-scale tests shall include *end-laps* if *end-laps* are required by the testing objective.

The tested *connection* type, size, and spacing shall be that specified for the test.

In large-scale tests, arc spot welds shall be measured, and the tested parameters shall conform to and be applied in accordance with the following:

- (a) Visible diameters of the outer surface of arc spot welds at *panel* supports are measured at all *panel side-laps* and at the adjacent interior flutes, if applicable. It is permitted to measure all transverse support welds.
- (b) Fused perimeters of all *side-lap* welds are measured.
- (c) The average measured visible diameter of arc spot welds at supports, d_{test} is used to calculate P_{nf} and $S_{ni\ theory}$, provided 90 percent of all measured welds at supports is within 25 percent of d_{test} . The visible diameter at each measured support weld is the average of two orthogonal measurements with one being the largest visible diameter at the weld.

where

P_{nf} = *Nominal weld shear strength [resistance]* of a *support connection* that is used to calculate $S_{ni\ theory}$.

$S_{ni\ theory}$ = *Calculated diaphragm shear strength [resistance]* per unit length for Test i

- (d) The average visible diameter of arc spot welds, $d_{s \text{ test}}$ at *side-lap connections* is used to calculate P_{ns} and $S_{ni \text{ theory}}$, provided 90 percent of all measured diameters is within 25 percent of $d_{s \text{ test}}$.

where

P_{ns} = Nominal weld shear strength [resistance] of a *side-lap connection* that is used to calculate $S_{ni \text{ theory}}$.

The visible diameter at each *side-lap* weld is calculated as follows:

- (1) For continuous perimeter fusion at the *side-lap* weld, use the average of two orthogonal measurements with one being the largest visible diameter at the weld.
- (2) For discontinuous perimeter fusion at the *side-lap* weld, use the relationship:

$$\text{Measured Visible Diameter} = \frac{\text{Measured Fused Perimeter}}{\pi} \quad (\text{Eq. E1.2.1-1})$$

In large-scale tests, *side-lap* welds, e.g. fillet, groove, or *top arc seam side-lap welds*, shall be measured and the parameters shall conform to and be applied in accordance with the following:

- (a) Fused lengths, L_w , at all *side-lap* welds are measured. For discontinuous fusion at a *side-lap* weld, L_w is the total of fully fused zones. See Figure D1.2.4-1 for a *top arc seam side-lap weld*.
- (b) The average fused length, $L_{w \text{ test}}$, of *side-lap welds* is the average of all measured fused lengths per weld. The average fused length is used to calculate P_{ns} and $S_{ni \text{ theory}}$, provided 90 percent of all measured fused lengths is within 25 percent of the average fused length.

User Note:

Separate analytical equations for *connection strength* and *flexibility* can be developed at butt joint (no end-lap) and end-lap conditions in *panels* at *exterior supports*. In this case, the smaller value of support *connection strength* [resistance], P_{nf} , and the greater *support connection flexibility*, S_f , can be used in design to calculate *nominal shear strength* [resistance] per unit length and *stiffness* for the *diaphragm* system when either butt joints or end-laps exist. If separate equations are not developed, industry practice often applies test results based on end-laps or combinations of end-laps and butt joints to design applications with butt joints. The converse is also true. However, some manufacturers use the potential benefit of end-lap end restraint from tests to increase *diaphragm* system *stiffness*.

The testing objectives are uniformity of welds and inclusion of the desired parameter range in the tested *configuration*. Welds will not match exactly the specified size. Some oversize welds may occur at touch-ups, which should not disallow a test. Weld prequalification procedures are recommended to control weld sizes.

E1.2.2 Test Calibration

Calibration shall be performed for small-scale and large-scale tests as described in Section E1.1. The *safety factor*, Ω , and *resistance factor*, ϕ , shall be determined in accordance with AISI S100 Eqs. K2.1.2-2 and K2.1.1-2, respectively. The calibrated *safety* and *resistance factors* shall be limited by those determined in accordance with Table B1.1. *Safety* and *resistance factors* shall be determined for the following test cases (a) through (c):

- (a) Where certain *connections* are tested in accordance with Section D1.1.5, D1.2.7 or D3.1 and *nominal diaphragm strength [resistance]*, S_n , and *stiffness*, G' , are determined analytically in accordance with Chapter D, the *connection safety factor*, Ω , and *resistance factor*, ϕ , based on small-scale tests, shall be determined in accordance with Section E1.2.2(b), provided the calibrated *safety* and *resistance factors* also conform to the following:
- (1) The *connection* and fastener *safety factor* shall be less than or equal to the *diaphragm system safety factor* required in Table B-1, and
 - (2) The *connection* and fastener *resistance factor* shall be greater than or equal to the *diaphragm system resistance factor* required in Table B-1.

In addition to limits (a) to (d) of Chapter D, the *diaphragm* system application shall also conform to the limits of the *connection* tests.

- (b) Small-scale tests to determine an analytical equation for *connection* strength, or large-scale tests to either determine an analytical equation for connection strength in an existing *diaphragm* system model or to verify a model's nominal *diaphragm shear strength [resistance]* per unit length shall conform to AISI S100 Section K2.1.1(b). Large-scale tests shall meet the additional requirements in Section E1.2.2(c). The calibration for small-scale and large-scale tests shall be in accordance with AISI S100 Section K2.1.1(c) as modified below:

$$C_\phi = \text{Calibration coefficient}$$

$$= 1.6 \text{ for LRFD}$$

$$= 1.5 \text{ for LSD}$$

$$P_m = \text{Mean value of professional factor, } P, \text{ for tested component}$$

$$= \frac{\sum_{i=1}^n \frac{R_{t,i}}{R_{n,i}}}{n} \quad (\text{AISI S100 Eq. K2.1.1-3})$$

where

$$i = \text{Index of tests}$$

$$= 1 \text{ to } n$$

$$n = \text{Total number of tests}$$

$$R_{t,i} = \text{Tested } \textit{connection strength [resistance]} \text{ of Test } i, \text{ or}$$

$$= \text{Tested } \textit{nominal diaphragm shear strength [resistance]} \text{ per unit length, } S_{ni \text{ test}}, \text{ of Test } i$$

$$R_{n,i} = \text{Calculated } \textit{connection strength [resistance]} \text{ of Test } i \text{ per } \textit{rational engineering analysis model}, \text{ or}$$

$$= \text{Calculated } \textit{nominal diaphragm shear strength [resistance]} \text{ per unit length, } S_{ni \text{ theory}}, \text{ of Test } i \text{ per } \textit{diaphragm system model}$$

$$V_Q = \text{Coefficient of variation of } \textit{load effect}$$

$$= 0.25 \text{ for LRFD and LSD}$$

$$V_P = \text{Coefficient of variation of test results determined in accordance with AISI S100 Eq. K2.1.1-6, but not less than } 0.065$$

$$C_P = \text{Correction factor, determined in accordance with AISI S100 Eq. K2.1.1-4}$$

$$\beta_o = \text{Target reliability index, determined in accordance with Table E1.2.2-1}$$

F_m = Mean value of fabrication factor, F , determined in accordance with Table E1.2.2-1

M_m = Mean value of material factor, M , determined in accordance with Table E1.2.2-1

V_F = Coefficient of variation of fabrication factor determined in accordance with Table E1.2.2-1

V_M = Coefficient of variation of material factor determined in accordance with Table E1.2.2-1

Table E1.2.2-1
Calibration Parameters β_o , F_m , M_m , V_F , V_M ¹

Diaphragm Conditions	β_o ^{2, 3}	F_m	M_m	V_F	V_M
Steel support	3.5 for <i>LRFD</i> 4.0 for <i>LSD</i>	AISI S100 Section K2.1.1(b)			
Structural concrete support or fill	3.5 for <i>LRFD</i> 4.0 for <i>LSD</i>	0.90	1.10	0.10	0.10
Insulating concrete fill	3.5 for <i>LRFD</i> 4.0 for <i>LSD</i>	AISI S100 Section K2.1.1(b)			
Wood support	4.0 for <i>LRFD</i> 4.5 for <i>LSD</i>	1.0	1.10	0.15	0.15

Note:

1. The most severe factors shall be used where fastener type or support varies in the *diaphragm*.
2. $\beta_o = 2.5$ is permitted in *LRFD* and by extension in *ASD* for wind load on *diaphragms* with steel supports and without structural or *insulating concrete* fill provided the limits of Table B1.1 are met.
3. $\beta_o = 3.5$ for all *load effects* in *LRFD* and by extension in *ASD*, and 4.0 for all *load effects* in *LSD* are permitted with wood supports provided *bearing* of the *panel* against the fastener controls the *connection* shear strength and the *bearing* strength controlled by wood is at least 25% greater than the steel *bearing* strength.

Table E1.2.2-2
Additional Requirements for Safety and Resistance Factors¹

Diaphragm Conditions	Sections for Additional Requirements
Steel support	Section B1
Structural concrete fill	ACI-318 for solid slab subjected to same load effect
Structural concrete support	Section D4.1
Insulating concrete fill	Section D4.1
Wood support	Section D1.1.4.1

Note:

1. Where *diaphragm* conditions are mixed, the most severe requirement applies.

User Note:

Although the contribution of *structural concrete* fill typically dominates *diaphragm* strength and *stiffness*, the *safety* and *resistance factors* are limited to the more severe case of strength controlled by the *deck connection*, or strength controlled by *structural concrete*. Where limited tests are performed and design is in accordance with Chapter D, the *safety* and *resistance factors* in Section D4.1 should apply. Otherwise, large-scale tests are performed and strength controlled by *structural concrete* is limited by the *safety* and *resistance factors* in ACI 318-11. The *safety* and *resistance factors* presented in ACI 318-11 are included below:

ACI 318-11 Concrete Slab Resistance Factors			
Diaphragm With Structural Concrete Type	ACI 318-11 Section	ϕ	Ω^1
With Supplemental Reinforcement	9.3.2.3	0.75	2.15
With Supplemental Reinforcement for Seismic Force-Resisting Systems Defined in ACI Section 9.3.4	9.3.4	See ACI Section 9.3.4	
Without Reinforcement	9.3.5	0.60	2.65

Note: ¹ For consistency with Chapter B, the *safety factor*, Ω , equals $1.6/\phi$ in the table above. Normally, the ACI *safety factor* equals $1.5/\phi$.

Table E1.2-1 defines the essential parameters when evaluating *connections* and *diaphragms*. AISI S905 and AISI S907 define the minimum number of tests and parameter distribution. All tests, including repeats of identical tests, are included in the total number of tests, n .

When determining a screw *nominal strength* [*resistance*] through tests in accordance with AISI S904 for use in a *diaphragm* strength model, the *safety factor*, Ω , and *resistance factor*, ϕ , are determined in accordance with this section.

- (c) Large-scale tests to develop, modify or verify a *connection* analytical equation in an existing *diaphragm* system model, or to extend the application limits of an existing system model shall conform to Section E1.2.2 (b) and the calibration shall be as modified below:

n = Total number of tests
 \geq Number required by AISI S907 for a given testing objective

$$\frac{R_{t,i}}{R_{n,i}} \geq 0.60 \quad (\text{Eq. E1.2.2-1})$$

$R_{t,i}$ = Tested *nominal diaphragm shear strength* [*resistance*] per unit length, $S_{ni \text{ test}}$, of Test i

$R_{n,i}$ = Calculated *nominal diaphragm shear strength* [*resistance*] per unit length, $S_{ni \text{ theory}}$, of Test i per *diaphragm* system model

C_P = Correction factor is determined as follows:

- (1) C_P is determined in accordance with AISI S100 Eq. K2.1.1-4, and
- (2) Where a tested system falls within or extends the limits of an existing analytical model, it is permitted to set $C_P = 1$

Exception: Where a test (i^{th} test) does not conform to Eq. E1.2.2-1, i.e., $\frac{R_{t,i}}{R_{n,i}} < 0.60$,

additional tests shall be performed in accordance with the following:

- (1) Repeat the i^{th} test that does not conform to Eq. E1.2.2-1. If the average of the two tests meets Eq. E1.2.2-1, both tests are used in the calibration.
- (2) If the average per item 1 does not meet Eq. E1.2.2-1 and there are no other test results in the tested range, the developed analytical equation for S_n excludes this tested range in the acceptable parameter limits.
- (3) If other tests in the same range of tested parameters as those in $R_{t,i}$ bound the nonconforming $R_{t,i}$ and the average over that range including the nonconforming $R_{t,i}$ conforms to Eq. E1.2.2-1, the developed analytical equation for S_n is permitted to include that range.

In large-scale tests with welded *connections* or any fastener that is subject to variation in size or installation quality, $R_{n,i}$ (i.e. $S_{ni \text{ theory}}$), shall be based on the average of *connection* sizes measured at the supports and the average of *connection* sizes measured at *side-laps*. Weld sizes are determined in accordance with Section E1.2.1.

It is permitted to apply the *safety* and *resistance factors* of an existing *diaphragm* system model to applications based on new large-scale test data without further calibration, provided:

- (1) New test data conforms to Eq. E1.2.2-1,
- (2) P_m determined using AISI S100 Eq. K2.1.1-3 equals or exceeds 0.95 with n being the number of new tests, and
- (3) New test data is equally weighted over the applicable range.

It is permitted to apply an existing *diaphragm* system equation for *stiffness* to applications based on new large-scale test data without further calibration, provided:

- (1) New test data conforms to Eqs. E1.2.2-2 and E1.2.2-3,

$$\frac{G'_{i \text{ test}}}{G'_{i \text{ theory}}} \geq 0.50 \quad (\text{Eq. E1.2.2-2})$$

$$\frac{1}{n} \sum_{i=1}^{i=n} \frac{G'_{i \text{ test}}}{G'_{i \text{ theory}}} \geq 0.70 \quad (\text{Eq. E1.2.2-3})$$

where

$G'_{i \text{ test}}$ = Tested *diaphragm stiffness* for an individual test, i

$G'_{i \text{ theory}}$ = Theoretical *diaphragm stiffness* for an individual test, i

n = Number of new tests

- (2) New test data is equally weighted over the applicable range.

If separate *connection* strength equations are developed at butt *joint* and end-laps for design, those strength equations shall be used to calculate the *nominal diaphragm shear strength [resistance]* per unit length, $S_{ni \text{ theory}}$, and the ratio, $\frac{R_{t,i}}{R_{n,i}}$, for large-scale tests.

User Note:

See Commentary Sections A4, E1.2, and E1.2.2 for additional information on existing *diaphragm* system models. The Chapter D impact of varying *connection* strength at *interior* and *exterior* supports can be determined by expanding Eqs. D1-1 and D1-5. This could apply where *support connections* or *thickness* vary, or where separate equations are used for the same *connection* at butt joints and end-laps.

E1.2.3 Laboratory Testing Reports

The laboratory testing report shall include the information specified in the applicable test standard.

E2 Single Diaphragm System

The requirements of Sections E1 and E1.1 shall apply to *single diaphragm systems* unless noted otherwise. The number of tests and test methods, including the testing of *configuration* parameters, shall be in accordance with the AISI S907 requirements for a *single diaphragm system*.

User Note:

A *single diaphragm system* is typically used to test a particular detail or design application for a project. AISI S907 evaluates *single diaphragm system* tests in accordance with AISI S100 Section K2.1.1(a), and defines the number of tests and repeatability requirements.

E2.1 Test System Requirements

The following conditions shall be satisfied:

- (a) The test structural supports and edge conditions are representative of the specified structure. Where more than one edge condition exists, the theoretically weakest condition or that chosen by the authority having jurisdiction is tested.
- (b) The specified *thickness* of the system *panel* is not less than 0.95 times the average tested base steel *thickness*. All tested base steel *thicknesses* are within five (5) percent of the average.
- (c) All tested *yield stresses* and tested *tensile strengths* are within 10 percent of the average tested *strengths*, respectively.

S_n and G' determined in accordance with Eqs. E2.1-1 and E2.1-2, respectively, shall be used in design. $S_{ni \text{ test}}$ shall be adjusted in accordance with Section E2.4.

$$S_n = \frac{1}{n} \sum_{i=1}^n S_{ni \text{ adj test}} \quad (\text{Eq. E2.1-1})$$

$$G' = \frac{1}{n} \sum_{i=1}^n G'_{i \text{ test}} \quad (\text{Eq. E2.1-2})$$

where

- S_n = Nominal shear strength [resistance] per unit length used in design and the average adjusted nominal shear strength [resistance] per unit length of all n tests
- n = Total number of tests for a *single diaphragm system*
- $S_{ni \text{ test}}$ = Tested shear strength [resistance] per unit length for an individual test, i
- $S_{ni \text{ adj test}}$ = Adjusted shear strength [resistance] per unit length for an individual test, i

- G' = Diaphragm stiffness used in design and the average of all n tests
 $G'_{i \text{ test}}$ = Tested diaphragm stiffness for an individual test, i

E2.1.1 Fastener and Weld Requirements

In all cases, the tested fastener type, size, and spacing shall be that specified:

- (a) Arc spot welds in *support connections* shall meet the following requirements:
- (1) The support welds shall be measured over the *deck* or *panel* supports at *panel side-laps* and at the adjacent interior flutes, if applicable. It is permitted to measure support welds in all flutes. The measured visible diameter at each support weld is the average of two orthogonal measurements with one being the largest visible diameter at the weld.
 - (2) The measured visible diameter of each arc spot weld shall not exceed the specified visible diameter, d , by more than 25 percent.
 - (3) d_{test} shall not exceed the specified visible diameter, d , by more than 15 percent in an individual test.
- (b) *Side-lap* welds in *side-lap connections* shall meet the following requirements:
- (1) All *side-lap* welds shall be measured.
 - (2) The measured visible diameter of each arc spot weld shall not exceed the specified visible diameter, d , by more than 25 percent. The measured visible diameter at each *side-lap* arc spot weld is calculated as follows:
 - (i) For full perimeter fusion at the *side-lap* weld, use the average of two orthogonal measurements with one being the largest visible diameter at the weld.
 - (ii) For discontinuous perimeter fusion at the *side-lap* weld, use the relationship:

$$\text{Measured Visible Diameter} = \frac{\text{Measured Fused Perimeter}}{\pi} \quad (\text{Eq. E2.1.1-1})$$
 - (4) For all *side-lap* welds, the average measured visible diameter, d_{test} , or average fused length, $L_{w \text{ test}}$, shall be within 15 percent of the specified visible diameter, d , or the specified *side-lap* weld length, L_w , as applicable. For discontinuous fusion at a *side-lap* weld, the measured L_w is the total length of fully fused zones at each weld.
 - (5) For *side-lap welds* along each *side-lap* seam, the average measured visible diameter of all arc spot welds at that seam, or the average measured fused length of all fillet, groove, or *top arc seam side-lap welds* at that seam shall be within 15 percent of the specified diameter, d , or specified length, L_w , respectively.

where

- d = Visible diameter of outer surface of arc spot weld
 d_{test} = Average measured visible diameter of the smallest set of 10 arc spot welds
 L_w = Length of fillet, groove, or *top arc seam side-lap weld*
 $L_{w \text{ test}}$ = Average fused length for the smallest set of 10 *side-lap* welds

Diaphragm shear strength per unit length reductions for welds shall be in accordance with Table E2.4.1-1 for systems without *structural concrete* fill over *deck*.

User Note:

Fused perimeter at arc spot welds or fused length is the indicator of *connection* strength since failure normally occurs at these perimeters. *Connection* strength equations are proportional to visible diameter or fused length. Adjustment to an equivalent perimeter or length is required at *side-lap* welds because “blow holes” or discontinuities might occur in tests at such welds, and “blow holes” do not contribute to strength.

E2.1.2 Concrete Requirements

Concrete compressive strength, f'_c , for structural concrete slabs (fill over deck) or structural concrete supports shall be greater than or equal to 2500 psi (17.2 MPa). The test curing time is permitted to be less than 28 days, but not less than 7 days, where test cylinders for slab or support indicate that $f'_{c \text{ test}}$ is or will be greater than the specified f'_c . Test cylinders shall be cured and tested as required by AISI S907.

For structural or insulating concrete fill, the difference between $d_{c \text{ test}}$ and specified d_c shall be less than or equal to 7.5 percent of the specified d_c for d_c less than or equal to 2 ½ in. (64 mm), and shall be less than or equal to 3/16 in. (5.0 mm) for specified d_c greater than 2 ½ in. (64 mm). Measurement shall be as specified by AISI S907.

where

d_c = Structural or insulating concrete thickness above top of deck

$d_{c \text{ test}}$ = Average tested structural or insulating concrete thickness over the top of the deck measured at supports

f'_c = Concrete compressive strength

$f'_{c \text{ test}}$ = Average tested concrete compressive strength for an individual test, i

User Note:

Minimum acceptable concrete compressive strength, f'_c , can also be limited by other design considerations such as fire rating and composite deck slab strength. See the controlling design specifications.

E2.2 Test Calibration

Calibration for a single diaphragm system shall be in accordance with Section E1.2.2(b) as modified below:

n = Total number of tests in accordance with AISI S907 for a single diaphragm system as specified in AISI S100 Section K2.1.1(a)

P_m = Mean value of professional factor, P , for tested component
= 1.0

It is permitted to apply the safety or resistance factors of an existing diaphragm system model to the nominal shear strength [resistance] per unit length determined through tests provided the configuration of the single diaphragm system meets the following conditions:

- (a) The configuration conforms to the limits of the existing diaphragm system model;
- (b) $S_{n \text{ theory}}$ is determined using the existing diaphragm system model; and
- (c) The ratio, $S_n/S_{n \text{ theory}}$, is bounded by the existing diaphragm model test database.

where

S_n = Nominal shear strength [resistance] per unit length of single diaphragm system defined by Eq. E2.1-1

$S_{n \text{ theory}}$ = Calculated nominal diaphragm shear strength [resistance] per unit length for a configuration based on the specified parameters

Where panel out-of-plane buckling controls the nominal diaphragm shear strength [resistance] per unit length, S_{nv} of the tested configuration, and the test set does not define the connection-related diaphragm shear strength [resistance] per unit length, the following two options shall be used to determine the safety and resistance factors:

- (1) The safety and resistance factors are permitted to be determined by calibration of the test results using the calibration parameters listed in Table E1.2.2-1. The calibrated safety factor shall be greater than and the resistance factor shall be less than the values determined:
 - (i) Using Section B Table B-1 where diaphragm strength is determined by calculation using Chapter D, and
 - (ii) Using Table B1.1 for the connection-related limit state.
- (2) It is permitted to apply the panel out-of-plane buckling factors, Ω_{db} or ϕ_{db} , of Section B1 to the nominal diaphragm shear strength [resistance] where:
 - (i) The single diaphragm system test is within the limits (a) through (d) of Chapter D, and
 - (ii) The available diaphragm shear strength [factored resistance] per unit length (S_{nf}/Ω_{df} or $\phi_{df}S_{nf}$) calculated in accordance with Section D1 does not control the available shear strength [factored resistance] of the tested single diaphragm system.

User Note:

The performance of a single diaphragm system is only applicable to that specific system, therefore the calibration follows AISI S100 Section K2.1.1(a). V_p , which indicates repeatability, is unique for the single diaphragm system. AISI S100 Section K2.1.1(a) does not require determination of a correlation coefficient, C_c .

Sections E1.2 and E1.2.2 of the Commentary provide information on existing test based systems and test data scatter.

E2.3 Laboratory Testing Reports

The laboratory testing report shall include the information specified in AISI S907 Section 13.

E2.4 Adjustment for Design

The nominal diaphragm shear strength [resistance] per unit length, S_{nv} of a single diaphragm system shall be determined in accordance with Eq. E2.1-1. Adjustment is required where any one specified d , t , F_w , d_c or f'_c is less than the corresponding d_{test} , t_{test} , $F_{u \text{ test}}$, $d_{c \text{ test}}$ or $f'_{c \text{ test}}$. The adjusted diaphragm shear strength [resistance] per unit length per test, $S_{ni \text{ adj test}}$ shall be modified relative to the as-tested shear strength [resistance] per unit length, $S_{ni \text{ test}}$ in accordance with Sections E2.4.1 for diaphragms without structural concrete fill and E2.4.2 for diaphragms with structural concrete fill.

$S_{ni \text{ adj test}}$ shall not be increased for any parameter where the specified value is greater than

or equal to the tested value for that parameter.

where

d_c = Structural or insulating concrete thickness above top of deck

$d_{c \text{ test}}$ = Average tested structural or insulating concrete thickness above top of the deck measured at supports

t = Base steel thickness of panel

t_{test} = Average value of tested panel's thickness for an individual test, i

f'_c = Structural or insulating concrete compressive strength

$f'_{c \text{ test}}$ = Average tested structural or insulating concrete compressive strength for an individual test, i

F_u = Specified tensile strength of sheet as determined in accordance with AISI S100 Sections A3.1 or A3.2

$F_{u \text{ test}}$ = Average value of tested panel's tensile strength for an individual test, i

$S_{ni \text{ test}}$ = Tested shear strength [resistance] per unit length for an individual test, i

Other parameters are defined in Section E2.1.

E2.4.1 Adjustment to Strength of Diaphragms Without Structural Concrete Fill

This section shall apply to *diaphragms* with *panels* only or with *insulating concrete* fill over *deck*, and shall include steel, wood or *structural concrete* supports. Reductions for each parameter listed in Section E2.4 or combination of parameters shall be applied to $S_{ni \text{ test}}$. The adjusted *diaphragm strength* [resistance], $S_{n \text{ adj test}}$ shall be determined in accordance with Table E2.4.1-1:

Table E2.4.1-1
Adjustment of Tested Nominal Diaphragm Strength, $S_{ni \text{ test}}$, Due to Variations
in Deck, Panel, Concrete Support or Insulating Fill Material From Specified Values

Condition	Modification ⁵
$\frac{t}{t_{\text{test}}} < 1$	$S_{ni \text{ adj test}} = \frac{t}{t_{\text{test}}} S_{ni \text{ test}}$
$\frac{F_u}{F_{u \text{ test}}} < 1$	$S_{ni \text{ adj test}} = \min\left(\frac{1.1F_u}{F_{u \text{ test}}}, 1\right) S_{ni \text{ test}}$
$\frac{t}{t_{\text{test}}} \& \frac{F_u}{F_{u \text{ test}}} < 1$	$S_{ni \text{ adj test}} = \frac{t}{t_{\text{test}}} \min\left(\frac{1.1F_u}{F_{u \text{ test}}}, 1\right) S_{ni \text{ test}}$
Weld ¹ $\frac{d}{d_{\text{test}}} < 1$	$S_{ni \text{ adj test}} = \frac{d}{d_{\text{test}}} S_{ni \text{ test}}$
$\frac{d}{d_{\text{test}}}, \frac{t}{t_{\text{test}}}, \& \frac{F_u}{F_{u \text{ test}}} < 1$	$S_{ni \text{ adj test}} = \frac{d}{d_{\text{test}}} \frac{t}{t_{\text{test}}} \min\left(\frac{1.1F_u}{F_{u \text{ test}}}, 1\right) S_{ni \text{ test}}$
Structural concrete support ² $\frac{f'_c}{f'_{c \text{ test}}} < 1$	$S_{ni \text{ adj test}} = \sqrt{\frac{f'_c}{f'_{c \text{ test}}}} S_{ni \text{ test}}$
Wood Support	See Note ⁴
Insulating Concrete Fill³	
$\frac{d_c}{d_{c \text{ test}}} \& \frac{f'_c}{f'_{c \text{ test}}} < 1$	$S_{ni \text{ adj test}} = 0.5 \left(1 + \frac{d_c}{d_{c \text{ test}}} \sqrt{\frac{f'_c}{f'_{c \text{ test}}}} \right) S_{ni \text{ test}}$
$\frac{d}{d_{\text{test}}}, \frac{t}{t_{\text{test}}}, \frac{F_u}{F_{u \text{ test}}}, \frac{f'_c}{f'_{c \text{ test}}}, \& \frac{d_c}{d_{c \text{ test}}} < 1$	$S_{ni \text{ adj test}} = 0.5 \left(\frac{d}{d_{\text{test}}} \frac{t}{t_{\text{test}}} \min\left(\frac{1.1F_u}{F_{u \text{ test}}}, 1\right) + \frac{d_c}{d_{c \text{ test}}} \sqrt{\frac{f'_c}{f'_{c \text{ test}}}} \right) S_{ni \text{ test}}$

Note:

1. Some variation is expected in d_{test} . See Section D1.1.1.
2. Reduction applies where *structural concrete bearing strength* controls the *support connection strength*.
3. At *concrete supports*, substitute $\sqrt{\frac{f'_c}{f'_{c \text{ test}}}}$ for $\frac{d}{d_{\text{test}}}$ in combined modifications.
4. Wood support size, species, and fastener conform to Sections E2.1(a) and E2.1.1 and reduction is not required for the *support connection*.
5. For a specified value greater than or equal to the tested value for that parameter, insert 1 at that particular ratio in the reduction equation.

where

- d = Visible diameter of outer surface of arc spot weld as specified and located over support
- d_{test} = Average measured visible diameter of the smallest set of 10 support arc spot welds for an individual test, i
- d_c = *Insulating concrete* thickness above top of *deck* as specified
- $d_{c \text{ test}}$ = Average tested *insulating concrete* thickness above top of the *deck* and at the

supports for an individual test, i

f'_c = *Insulating concrete compressive strength [resistance]* as specified for fill
 = *Structural concrete compressive strength [resistance]* as specified for *structural concrete* support

$f'_{c \text{ test}}$ = Average tested *insulating concrete compressive strength [resistance]* for an individual test, i
 = Average tested *structural concrete compressive strength [resistance]* for an individual test, i , for *structural concrete* supports

Other parameters are defined in Section E2.1 and E2.4.

User Note:

The adjustment for lightweight *insulating concrete* depth or *compressive strength* variation from specified values should be made in accordance with Section E2.4.1. *Diaphragm* shear strength per unit length with lightweight *insulating concrete* fill without insulating board can be calculated in accordance with Eq. D4.3-1. Table E2.4.1-1 uses this relationship and rationalizes that both *deck* and lightweight *insulating concrete* fill provide significant contributions to *insulating concrete-filled diaphragm* strength. The Table E2.4.1-1 adjustment is applicable as long as the tested properties are close to specified values since it assigns relatively equal weight to each contribution.

Table E2.4.1-1 assumes that the support is sufficiently thick so its properties do not control *connection* strength. If this is not the case, an adjustment can be made by replacing *panel thickness*, t , with t_{support} and replacing *panel tensile strength*, F_u , with $F_{u \text{ support}}$.

f'_c and d_{test} should be determined in accordance with AISI S907.

E2.4.2 Adjustment to Strength of Diaphragms With Structural Concrete Fill

Tested *strength [resistance]*, $S_{ni \text{ test}}$ for diaphragms with concrete fill over deck shall be adjusted in accordance with this section. The adjusted diaphragm strength [resistance], $S_{ni \text{ adj test}}$ shall be determined in accordance with Table E2.4.2-1:

Table E2.4.2-1
Adjustment of Nominal Diaphragm Strength, $S_{ni \text{ test}}$,
due to Variations in Structural Concrete Fill Relative to Specified Values

Condition	Modification
$\frac{f'_c}{f'_{c \text{ test}}} < 1$	$S_{ni \text{ adj test}} = \sqrt{\frac{f'_c}{f'_{c \text{ test}}}} S_{ni \text{ test}}$
$\frac{d_c}{d_{c \text{ test}}} < 1$	$S_{ni \text{ adj test}} = \frac{d_c}{d_{c \text{ test}}} S_{ni \text{ test}}$
$\frac{d_c}{d_{c \text{ test}}} \& \frac{f'_c}{f'_{c \text{ test}}} < 1$	$S_{ni \text{ adj test}} = \frac{d_c}{d_{c \text{ test}}} \sqrt{\frac{f'_c}{f'_{c \text{ test}}}} S_{ni \text{ test}}$

where

d_c = *Structural concrete* thickness above top of *deck* as specified

$d_{c \text{ test}}$ = Average tested *structural concrete* thickness above top of the *deck* at the supports for an individual test, i

- f'_c = Structural concrete compressive strength [resistance] as specified for fill
 = Structural concrete compressive strength [resistance] as specified for structural concrete support
- $f'_{c \text{ test}}$ = Average tested structural concrete compressive strength [resistance] for fill in an individual test, i
 = Average tested structural concrete compressive strength [resistance] for structural concrete supports in an individual test, i
- $S_{ni \text{ test}}$ = Tested diaphragm shear strength [resistance] per unit length for an individual test, i
- $S_{ni \text{ adj test}}$ = Adjusted diaphragm shear strength [resistance] per unit length for an individual test, i

User Note:

$f'_{c \text{ test}}$ and $d_{c \text{ test}}$ should be determined in accordance with AISI S907. Table E2.4.2-1 assumes that structural concrete fill provides most of the nominal diaphragm shear strength [resistance] per unit length of the diaphragm system and that sufficient support connections are present to allow this.

Table E2.4.2-1 should be based on f'_c and $f'_{c \text{ test}}$ for the structural concrete fill. If the support connection controls $S_{ni \text{ test}}$, use the support ratio, $\sqrt{\frac{f'_c}{f'_{c \text{ test}}}}$, as the modifier. However, fill

modifiers, $\frac{d_c}{d_{c \text{ test}}} \sqrt{\frac{f'_c}{f'_{c \text{ test}}}}$, need not be used in combination with the support modifier.

E2.5 Test Results Interpretation

The test results of a single diaphragm system shall be applied to applications as specified in the test's objective. The test results of a single diaphragm system with a single span are permitted to be used in a design having multiple spans provided the following conditions are satisfied:

- The span of panel between supports with fasteners, L_v , of the multiple span application is the same as that of the tested single span diaphragm system.
- The number of connections at exterior supports equals the number of connections in the tested single span diaphragm system, and the number of connections at interior supports is increased in accordance with the analytical method of Section D1. The increased number of connections at interior supports shall provide equivalent or greater calculated multiple span system diaphragm strength relative to the calculated diaphragm system strength of the tested single span system with calculations based on the specified design application parameters. All calculation parameters other than panel length, L , and number of interior support connections are held constant including panel profile, thickness, yield stress, tensile strength, support connection type, side-lap connection type and spacing, span of panel between supports with fasteners, L_v , and where applicable, concrete fill type, compressive strength, and depth. As compared to the exterior supports, the additional interior support fasteners shall be located closest to side-laps with one installed in each flute and progressing to the center of the deck or panel. The number of fasteners at end-laps over exterior supports shall be the same as that required at interior supports.

User Note:

See Figure D1-1 for clarification of *exterior* and *interior supports*. The difference in the required number of fasteners at *interior* and *exterior supports* is reflected in the variable, β , in Eqs. D1-1 and D1-2, where $\alpha_p^2 \neq \alpha_e^2$ in the multi-span case (say $L = 2L_v$ for two spans) and $n_p = 0.0$ in single spans.

Appendix 1: Determination of Factors, D_n and γ_c

1.1 General

1.1.1 Scope

This appendix addresses the determination of the warping factor, D_n , and the support factor, γ_c , that are required to analytically determine the *stiffness*, G' , in Section D5.

1.1.2 Applicability

This appendix applies to perforated and non-perforated profiled *panels* that conform to the limits (a) to (d) of Chapter D. It is permitted to set $D_n = 0$ for perforated or non-perforated *cellular deck* that conform to the limits (a) to (g) of Section D1.5.

1.2 Determination of Warping Factor, D_n

Where the analytical method of Chapter D is used, *stiffness*, G' , shall be determined in accordance with Eq. D5.1.1-1, in which D_n shall be determined in accordance with this appendix. Section 1.4 shall be used where insulation is not present beneath the *panel*. Section 1.5 shall be used where insulation is present beneath the *panel* and the *diaphragm* meets the limits (a) to (f) of Section D1.3. Section 1.6 shall be used where perforations are present in *acoustic panels*.

It is permitted to determine G' by test in accordance with Chapter E. It is permitted to use existing *diaphragm* system theories to include the end warping effect in accordance with Section E1.2.

User Note:

Section 1.4 can also be used for *diaphragm* systems with insulation between the *panel* and the support as long as the fluted *panel* meets the requirements (a) to (d) as specified in Chapter D. Chapter D does not consider increased *stiffness* caused by insulation above the *panel* with the exception of *insulating concrete* fill. Section 1.5 can be used for *diaphragm* systems without insulation between the *panel* and the support provided the fluted *panel* meets the requirements (a) to (f) specified in Section D1.3.

Where Chapter E is used, the test will include the end warping contribution.

1.3 Determination of Support Factor, γ_c

Support factor, γ_c , in Eq. D5.1.1-1 shall be determined in accordance with Table 1.3-1.

Table 1.3-1
Support Factor, γ_c

Spans	1	2	3	4	5	6	≥ 7
γ_c	1.00	1.00	0.90	0.80	0.71	0.64	0.58

1.4 Determination of Warping Factor Where Insulation Is Not Present Beneath the Panel

D_n for profiled *panels* shall be determined using the dimensions defined in Section D2.1 and the parameters as shown in Figure 1.4-1.

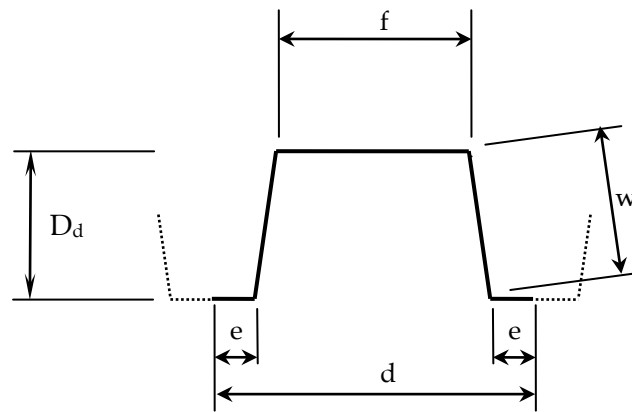

Figure 1.4-1 Panel Configuration

The unitless warping factor, D_n , shall be developed using equation, Eq. 1.4-1:

$$D_n = \frac{D}{L} \quad (\text{Eq. 1.4-1})$$

where

D = Weighted average D_i value for warping across the *panel* width, w , in. (mm)

$$= \frac{U_1 D_1 + U_2 D_2 + U_3 D_3 + U_4 D_4}{U_1 + U_2 + U_3 + U_4} \quad (\text{Eq. 1.4-2})$$

D_1 = Value for warping where bottom flange fastener is in every valley

$$= \frac{\gamma_1 f}{d(t)^{1.5}} \quad \text{in. (mm)} \quad (\text{Eq. 1.4-3})$$

D_2 = Value for warping where bottom flange fastener is in every second valley

$$= \frac{\gamma_2 f}{2d(t)^{1.5}} \quad \text{in. (mm)} \quad (\text{Eq. 1.4-4})$$

D_3 = Value for warping where bottom flange fastener is in every third valley

$$= \frac{\gamma_3 f}{3d(t)^{1.5}} \quad \text{in. (mm)} \quad (\text{Eq. 1.4-5})$$

D_4 = Value for warping where bottom flange fastener is in every fourth valley

$$= \frac{\gamma_4 f}{4d(t)^{1.5}} \quad \text{in. (mm)} \quad (\text{Eq. 1.4-6})$$

U_1 = Number of corrugations having fasteners in every valley across the *panel* width, w

U_2 = Number of corrugations having fasteners in every second valley across the *panel* width, w

U_3 = Number of corrugations having fasteners in every third valley across the *panel* width, w

U_4 = Number of corrugations having fasteners in every fourth valley across the *panel* width, w

L = Total *panel* length, in. (mm)

User Note:

The warping factor, D_{nr} , measures both the lateral racking and accordion distortion of *panels* and the arching of corrugations between support fasteners. This distortion is localized near the *panel* ends and the equation indicates that the impact is reduced at longer *panel* lengths.

The warping parameter, D , considers the panel profile and connection spacing at panel ends.

The D value for warping shall be developed using Eq. 1.4-7 through Eq. 1.4-34.

where

s = Developed flute width per *pitch*

$$= f + 2e + 2w$$

(Eq. 1.4-7)

δ_{ij} = Deflection indicator of profile racking per unit *load* per unit length required for D , in.³ (mm³)

κ_{ij} = Spring constant indicator required for D , $\frac{1}{\text{in.}^3} \left(\frac{1}{\text{mm}^3} \right)$

User Note:

The relationship between the deflection, Δ_{ij} , at joint, i , on a *panel* caused by a unit *load* per unit length at joint, j , on the *panel* and the deflection indicator, δ_{ij} , is as follows:

$$\Delta_{ij} = \frac{\delta_{ij}}{EI_y} \quad \text{in./kip/in (mm/kN/mm)}$$

See the *Commentary* on Appendix 1-4 and SDI DDM01, Appendix A, for an explanation of the subscripts and *load* point locations. For Δ_{ij} and δ_{ij} , $ij = 11, 12, 22$.

The relationship between the spring constant, K_{ij} , at joint, i , on a *panel* associated with a bottom flat *connection* spacing or released restraint, j , on the *panel* and the spring constant indicator, κ_{ij} , is as follows:

$$K_{ij} = EI_y \kappa_{ij} \quad \text{kip/in./in. (kN/mm/mm)}$$

$$I_y = \frac{bt^3}{12} \quad \text{in.}^4 / \text{in.} \cdot (\text{mm}^4 / \text{mm})$$

where

b = unit length of the *panel*, 1 in. or 1 mm, as applicable

For K_{ij} and κ_{ij} , $ij = t1, t2, t3, t4, b2, b3, b4, tc3, tc4, bc4$. The subscripts, tc and bc , apply to spring constants at the top or bottom of central flutes where bottom flats are not restrained at cases $j = 3$ or 4. There is 1 central flute at $j = 3$ and there are 2 central flutes at $j = 4$.

where

$$\delta_{11} = \frac{D_d^2}{3} (2w + 3f) \quad \text{(Eq. 1.4-8)}$$

$$\delta_{12} = \frac{\delta_{11}}{2} \quad (\text{Eq. 1.4-9})$$

$$\delta_{22} = \frac{1}{12} \left(\frac{D_d}{d} \right)^2 \left[s(4e^2 - 2ef + f^2) + d^2(3f + 2w) \right] \quad (\text{Eq. 1.4-10})$$

$$\kappa_{t1} = \frac{1}{\delta_{22} - \frac{\delta_{12}}{2}} \quad (\text{Eq. 1.4-11})$$

$$\kappa_{t2} = \frac{1}{\left(\frac{2e}{f} \right) \left(\frac{\delta_{12}}{2} \right) + \delta_{22}} \quad (\text{Eq. 1.4-12})$$

$$\kappa_{t3} = \frac{1}{\left(0.5 + \frac{2e}{f} \right) \delta_{12} + \delta_{22}} \quad (\text{Eq. 1.4-13})$$

$$\kappa_{t4} = \frac{1}{\left(1 + \frac{3e}{f} \right) \delta_{12} + \delta_{22}} \quad (\text{Eq. 1.4-14})$$

$$\kappa_{b2} = \frac{\frac{2e}{f}}{\frac{2e}{f} \frac{\delta_{11}}{2} + \delta_{12}} \quad (\text{Eq. 1.4-15})$$

$$\kappa_{b3} = \frac{\frac{2e}{f}}{\left(0.5 + \frac{2e}{f} \right) \delta_{11} + \delta_{12}} \quad (\text{Eq. 1.4-16})$$

$$\kappa_{b4} = \frac{\frac{2e}{f}}{\left(1 + \frac{3e}{f} \right) \delta_{11} + \delta_{12}} \quad (\text{Eq. 1.4-17})$$

$$\kappa_{tc3} = \frac{1}{\left(0.5 + \frac{2e}{f} \right) \delta_{11} + \delta_{22} + \frac{\delta_{12}}{2}} \quad (\text{Eq. 1.4-18})$$

$$\kappa_{tc4} = \frac{1}{\left(1.0 + \frac{3e}{f} \right) \delta_{11} + \delta_{22} + \left(1.0 + \frac{e}{f} \right) \delta_{12}} \quad (\text{Eq. 1.4-19})$$

$$\kappa_{bc4} = \frac{\frac{2e}{f}}{\left(1 + \frac{4e}{f} \right) \delta_{11} + 2\delta_{12}} \quad (\text{Eq. 1.4-20})$$

δ_{ti} = Lateral displacement indicator at top of corrugation for valley fastener cases,
 $i = 1$ to 4 , in.^{2.5}(mm^{2.5})

δ_{bi} = Lateral displacement indicator at bottom of corrugation for valley fastener cases,

$$i = 1 \text{ to } 4, \text{ in.}^{2.5}(\text{mm}^{2.5})$$

$\delta_{b1} = 0$ for fasteners in the bottom flat of each flute.

$$\delta_{t1} = \frac{24f}{\kappa_{t1}} \left[\frac{\kappa_{t1}}{4f^2(f+w)} \right]^{0.25} \quad (\text{Eq. 1.4-21})$$

$$\delta_{t2} = \frac{24f}{\kappa_{t2}} \left[\frac{\kappa_{t2}}{4f^2(f+w)} \right]^{0.25} \quad (\text{Eq. 1.4-22})$$

$$\delta_{t3} = \frac{24f}{\kappa_{t3}} \left[\frac{\kappa_{t3}}{4f^2(f+w)} \right]^{0.25} \quad (\text{Eq. 1.4-23})$$

$$\delta_{t4} = \frac{24f}{\kappa_{t4}} \left[\frac{\kappa_{t4}}{4f^2(f+w)} \right]^{0.25} \quad (\text{Eq. 1.4-24})$$

$$\delta_{b2} = \frac{48e}{\kappa_{b2}} \left[\frac{\kappa_{b2}}{16e^2(2e+w)} \right]^{0.25} \quad (\text{Eq. 1.4-25})$$

$$\delta_{b3} = \frac{48e}{\kappa_{b3}} \left[\frac{\kappa_{b3}}{16e^2(2e+w)} \right]^{0.25} \quad (\text{Eq. 1.4-26})$$

$$\delta_{b4} = \frac{48e}{\kappa_{b4}} \left[\frac{\kappa_{b4}}{16e^2(2e+w)} \right]^{0.25} \quad (\text{Eq. 1.4-27})$$

$$\delta_{tc3} = \frac{24f}{\kappa_{tc3}} \left[\frac{\kappa_{tc3}}{4f^2(f+w)} \right]^{0.25} \quad (\text{Eq. 1.4-28})$$

$$\delta_{tc4} = \frac{24f}{\kappa_{tc4}} \left[\frac{\kappa_{tc4}}{4f^2(f+w)} \right]^{0.25} \quad (\text{Eq. 1.4-29})$$

$$\delta_{bc4} = \frac{48e}{\kappa_{bc4}} \left[\frac{\kappa_{bc4}}{16e^2(2e+w)} \right]^{0.25} \quad (\text{Eq. 1.4-30})$$

γ_i = Final displacement indicator at top of corrugation for valley fastener cases,
 $i = 1$ to 4, in.^{2.5}(mm^{2.5})

$$\gamma_1 = \delta_{t1} \quad (\text{Eq. 1.4-31})$$

$$\gamma_2 = 2\delta_{t2} + \frac{2e}{f}\delta_{b2} \quad (\text{Eq. 1.4-32})$$

$$\gamma_3 = 2\delta_{t3} + \delta_{tc3} + 2\left(\frac{2e}{f}\right)\delta_{b3} \quad (\text{Eq. 1.4-33})$$

$$\gamma_4 = 2(\delta_{t4} + \delta_{tc4}) + \left(\frac{2e}{f}\right)(2\delta_{b4} + \delta_{bc4}) \quad (\text{Eq. 1.4-34})$$

1.5 Determination of Warping Factor Where Insulation is Present Beneath the Panel

Where the limits of Chapter D are met and *panel* depth, D_d , is less than or equal to 4 in. (102 mm), it is permitted to use the simplified Eq. 1.5-1 whether or not insulation is present. Section 1.5 shall not apply to perforated *panels*.

Parameters are defined in Section D2.1 and shown in Figure 1.4-1.

$$D_n = \frac{1}{n} \sum_{i=1}^n D_{ni} \quad (\text{Eq. 1.5-1})$$

where

D_n = Warping factor considering distortion at *panel* ends
 = Average of each corrugation's D_{ni} for the entire *panel* width, w

D_{ni} = Warping factor for each corrugation, i

$$= \frac{D_d f^2}{25\alpha L} \left(\frac{1}{t}\right)^{1.5} \quad \text{For } \psi = 1 \quad (\text{Eq. 1.5-2})$$

$$= \frac{0.94d\psi^2}{f} \left(\frac{D_d f^2}{25\alpha L}\right) \left(\frac{1}{t}\right)^{1.5} \quad \text{For } 1 < \psi \leq 3 \quad (\text{Eq. 1.5-3})$$

where

α = Conversion factor
 = 1 for U.S. customary units
 = 420 for SI units

ψ = Number of corrugations between support fasteners at the *panel* end for the set of corrugations containing the corrugation, i .

Unit of the parameters in Eqs. 1.5-2 and 1.5-3 are defined:

Variables	U.S. Customary	SI
D_d, g, f, w, e, d, t	in.	mm
L	ft	m

$$n = \text{Number of corrugations in a total } \textit{panel} \text{ cover width, } w;
 = \frac{w}{d} \quad (\text{Eq. 1.5-4})$$

User Note:

$\psi = 2$ for alternate valley spacing. The Section 1.5 equations are based on a parametric study of the Section 1.4 method. The value, D_n , will not always be exactly the same using the two methods. The Section 1.4 method is required for final design when ψ is greater than 3.

1.6 Determination of Warping Factor for Perforated Deck

The warping value, D , in Eq. 1.4-1 shall be determined using the modified values, e_p , f_p , and w_p for the profile parameters, e , f , and w in Eq. 1.4-7 through Eq. 1.4-10. The modification shall be in accordance with Eq. 1.6-1 through Eq. 1.6-3.

$$e_p = K_{E_e}^{1/3} e \quad (\text{Eq. 1.6-1})$$

$$f_p = K_{E_f}^{1/3} f \quad (\text{Eq. 1.6-2})$$

$$w_p = K_{E_w}^{1/3} w \quad (\text{Eq. 1.6-3})$$

where

K_{E_i} = Indicator of relative flexural stiffness of an element without perforations to the stiffness of the element with perforations over part of its length

$$K_{E_i} = 1 + A_i^3 \left(\frac{1}{k} - 1 \right) \quad (\text{Eq. 1.6-4})$$

where

A_i = Ratio of perforated width to the full element width

i = Index of perforated elements in a profile

= e at bottom flat

= w at *web*

= f at top flat

A_e = Ratio of bottom perforated width to the bottom width

A_f = Ratio of top perforated width to the top width

A_w = Ratio of *web* perforated width to the *web* width

k = Ratio of the perforated element stiffness relative to that of a solid element

$$= 0.9 + p_o^2 - 1.875p_o \quad \text{for } 0.2 \leq p_o \leq 0.58 \quad (\text{Eq. 1.6-5})$$

where

p_o = Ratio of the area of perforations to the total area in the perforated band

User Note:

See the *Commentary* for a recommendation when $p_o < 0.2$.

Appendix 2: Strength at Perimeter Load Delivery Point

2.1 General

2.1.1 Scope

This appendix determines the following:

- Forces on *panels* and *connections* fastened to perimeter supports perpendicular to the *panel* span, and
- Available shear strength [factored resistance] per unit length of a *diaphragm* where perimeter *connections* are loaded.

2.1.2 Applicability

This appendix applies to perforated and non-perforated profiled *panels* and perforated and non-perforated *cellular deck* that are fastened to perimeter supports having limited weak axis bending stiffness when collection struts or wind trusses are not present to transfer *load* into the *diaphragm*.

2.2 Connection Design

The *nominal diaphragm shear strength [resistance]* per unit length, S_{nf} , shall be determined using Eq. 2.2-1. Parameters are defined in Section D1. See Figure 2.2-1.

For ASD

$$S_{nf} = \left(\frac{\beta N}{N^2 L^2 + \beta^2} \right) \left(-\Omega_{df} w_a L + \sqrt{\Omega_{df}^2 w_a^2 L^2 + (N^2 L^2 + \beta^2) \left(P_{nf}^2 - \Omega_{df}^2 \frac{w_a^2}{N^2} \right)} \right) \quad (Eq. 2.2-1a)$$

For LRFD and LSD

$$S_{nf} = \left(\frac{\beta N}{N^2 L^2 + \beta^2} \right) \left(\frac{-w_u L}{\phi_{df}} + \sqrt{\frac{w_u^2 L^2}{\phi_{df}^2} + (N^2 L^2 + \beta^2) \left(P_{nf}^2 - \frac{w_u^2}{\phi_{df}^2 N^2} \right)} \right) \quad (Eq. 2.2-1b)$$

where

w_a = External *nominal load reaction*, kip/ft (kN/m), requiring *allowable diaphragm strength*, S_{nf} / Ω_{df}

w_u = Factored external *nominal load reaction*, kip/ft (kN/m), demanding the *design diaphragm strength [factored resistance]*, $\phi_{df} S_{nf}$

L = Total *panel length*, ft (m) [at perimeter]

N = Number of *support connections* per unit width at an *interior* or *edge panel's end* (perimeter *panel end* in this particular case), 1/ft (1/m)

P_{nf} = *Nominal shear strength [resistance]* of a *support connection* per fastener in accordance with Section D1.1, kip (kN) (at perimeter *panel end*)

S_{nf} = *Nominal shear strength [resistance]* per unit length of *diaphragm system* controlled by *connections*, kip/ft (kN/m)

ϕ_{df} = Connection resistance factor for diaphragm strength controlled by connections and determined in accordance with Table B-1

Ω_{df} = Safety factor for diaphragm strength controlled by connections and determined in accordance with Table B-1

User Note:

Eq. D1-2 is a special case of Eq. 2.2-1a where $w_a = 0.0$ or Eq. 2.2-1b where $w_u = 0.0$. Statics analysis indicates that all shear would flow from the chord (beam flange) into the diaphragm along this line. The force component per fastener at that perimeter is:

$$\frac{S_n}{\Omega_d N} \text{ or } \frac{\phi_d S_n}{N}$$

Eq. 2.2-1 is derived from the free body diagram in Figure 2.2-1. The statics requirement is covered by Eq. D1-2 when w_a or w_u is not present.

Loads causing compression in the panel are discussed in Section 2.3, and loads causing tension in the panel are discussed in Section 2.4. Both should be considered.

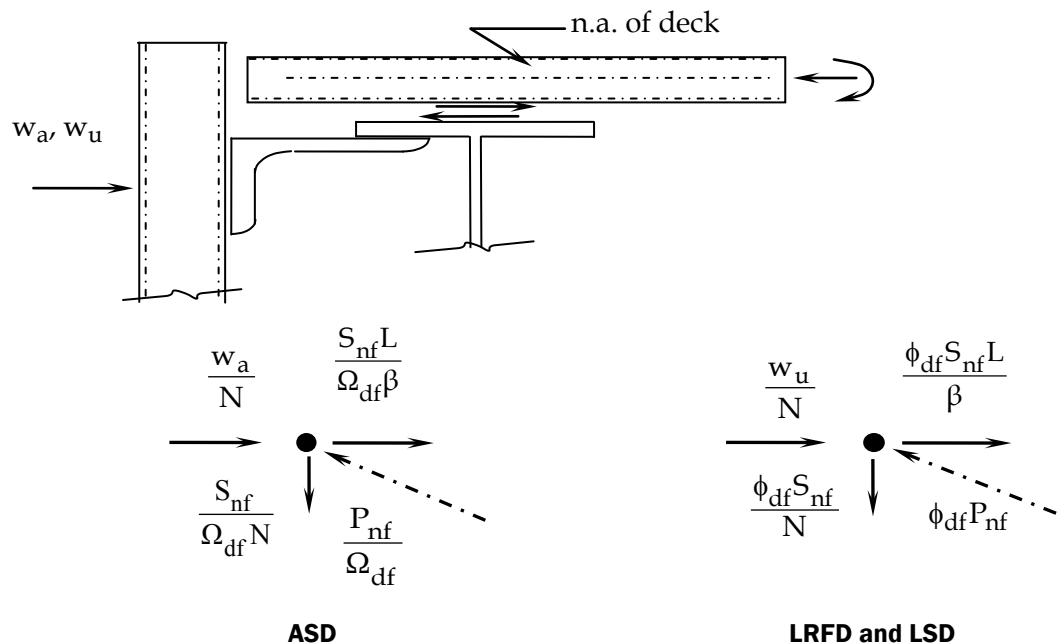

Figure 2.2-1 Free Body of Corner Fastener

2.3 Axial Compression Design in Panel

User Note:

Design is an application of AISI S100 Sections E2 and E3 and Section H2.

$$P_n = A_e F_n \quad (\text{AISI S100 Eq. E3.1-1})$$

where

A_e = Effective area per unit width of panel at stress F_n , in.²/ft (m²/m)

F_n = Compressive stress at the nominal axial strength, kip/in.² (kN/m²)

P_n = Nominal compressive axial strength [resistance] of panel per unit width, kip/ft (kN/m)

$$\text{For } \lambda_c \leq 1.5 \quad F_n = \left(0.658^{\lambda_c^2}\right) F_y \quad (\text{AISI S100 Eq. E2-2})$$

$$\text{For } \lambda_c > 1.5 \quad F_n = \left(\frac{0.877}{\lambda_c^2}\right) F_y \quad (\text{AISI S100 Eq. E2-3})$$

$$\lambda_c = \sqrt{\frac{F_y}{F_{cre}}} \quad (\text{AISI S100 Eq. E2-4})$$

$$F_{cre} = \frac{\pi^2 E}{\left(\frac{KL_v}{r}\right)^2} \quad (\text{AISI S100 Eq. E2.1-1})$$

$$r = \left(\frac{I_{xg}}{A_g}\right)^{1/2} \quad (\text{Eq. 2.3-1})$$

where

r = Radius of gyration of panel, in. (m)

A_g = Area of fully effective (unreduced) panel per unit width, in.²/ft (m²/m)

E = Modulus of elasticity of steel

F_{cre} = Elastic flexural buckling stress of panel, kip/in.² (kN/m²)

F_y = Yield stress of specified steel, kip/in.² (kN/m²)

I_{xg} = Moment of inertia of fully effective (unreduced) panel per unit width, in.⁴/ft (m⁴/m)

K = Effective length factor

L_v = Span of panel between supports with fasteners

λ_c = Slenderness factor

User Note:

Compression in a panel rarely controls. K can conservatively be set as 1. If a concern over shear lag exists, rational design might limit column resistance to the corrugations on either side of the end support connection - e.g., if connection spacing is three corrugations, base A_e on two corrugations and adjust P_n to per unit width consistent with the required compressive axial strength.

2.3.1 Combined Compressive Axial Load and Bending in Panel

For ASD

$$\frac{\Omega_c P}{P_n} + \frac{\Omega_b M_x}{M_n} \leq 1.0 \quad (\text{Particular application of AISI S100 Eq. H1.2-1})$$

For LRFD or LSD

$$\frac{\bar{P}}{\phi_c P_n} + \frac{\bar{M}_x}{\phi_b M_n} \leq 1.0 \quad (\text{Particular application of AISI S100 Eq. H1.2-1})$$

where

P = Required compressive axial strength [compression force] per unit width for ASD

= w_a , kip/ft (kN/m)

- \bar{P} = Required compressive axial strength [factored compression force] per unit width for LRFD and LSD
 = w_u , kip/ft (kN/m)
- M_n = Nominal flexural strength [moment resistance] of deck or panel per unit width, in. kip/ft (kN m/m)
 = $S_x F_y$ (AISI S100 Eq. F3.1-1)
- S_x = Effective section modulus of panel at stress F_y , in.³/ft (m³/m)
- M_x = Required flexural strength [moment] per unit width in ASD
 = $y_b P$, in. kip/ft (kN m/m) (Eq. 2.3.1-1)
- y_b = Distance from panel neutral axis to bottom flat connection, in. (m)
- \bar{M}_x = Required flexural strength [factored moment] per unit width in LRFD and LSD
 = $y_b \bar{P}$, in. kip/ft (kN m/m) (Eq. 2.3.1-2)
- Ω_c = 1.80 ASD
- ϕ_c = 0.85 LRFD or LSD
 = 0.80 LSD
- Ω_b = 1.67 ASD
- ϕ_b = 0.90 LRFD or LSD
- Other parameters are defined in Section 2.2.

User Note:

Other loads simultaneously can cause other bending moment, M_x or \bar{M}_x , in the panel.

2.4 Axial Tension Design in Panel

2.4.1 Combined Tensile Axial Load and Bending in Panel

User Note:

Where w_a or w_u can be significantly different than the compressive value, this limiting condition should be investigated for the panel. S_{nf} is determined using Eq. 2.2-1 and the greater value of w_a or w_u . Other loads simultaneously can cause other bending moment in the panel.

Design is an application of AISI S100 Section D2 and Section H1.

For ASD

$$\frac{\Omega_t T}{T_n} + \frac{\Omega_b M_x}{M_n} \leq 1.0 \quad (\text{Particular application of AISI Eq. H1.1-1})$$

For LRFD or LSD

$$\frac{\bar{T}}{\phi_t T_n} + \frac{\bar{M}_x}{\phi_b M_n} \leq 1.0 \quad (\text{Particular application of AISI Eq. H1.1-1})$$

where

- T_n = Nominal tensile axial strength [resistance] of panel per unit width, kip/ft (kN/m)
 = $A_g F_y$ (Eq. 2.4-1)
- T = Required tensile axial strength [tension force] per unit width for ASD
 = w_a , kip/ft (kN/m)

\bar{T} = Required tensile axial strength [factored tension force] per unit width for LRFD and LSD
= w_u , lb/ft (kN/m)

M_x = Required flexural strength [moment] per unit width in ASD
= $y_b T$, in. kip/ft (kN m/m) (Eq. 2.4-2)

\bar{M}_x = Required flexural strength [factored moment] per unit width in LRFD and LSD
= $y_b \bar{T}$, in. kip/ft (kN m/m) (Eq. 2.4-3)

Ω_t = 1.67 ASD

ϕ_t = 0.90 LRFD or LSD

Other parameters are defined in Sections 2.3 and 2.3.1.



AISI STANDARD

Commentary on the North American Standard for the Design of Profiled Steel Diaphragm Panels

2016 EDITION

The material contained herein has been developed by the American Iron and Steel Institute (AISI) Committee on Specifications. The Committee has made a diligent effort to present accurate, reliable, and useful information on cold-formed steel *diaphragm* design. The Committee acknowledges and is grateful for the contributions of the numerous researchers, engineers, and others who have contributed to the body of knowledge on the subject. Specific references are included in the *Commentary* on the *Standard*.

With anticipated improvements in understanding of the behavior of cold-formed steel *diaphragms* and the continuing development of new technology, this material may eventually become dated. It is anticipated that future editions of this *Standard* will update this material as new information becomes available, but this cannot be guaranteed.

The materials set forth herein are for general information only. They are not a substitute for competent professional advice. Application of this information to a specific project should be reviewed by a registered professional engineer. Indeed, in most jurisdictions, such review is required by law. Anyone making use of the information set forth herein does so at their own risk and assumes any and all resulting liability arising therefrom.

1st Printing – October, 2016

Produced by American Iron and Steel Institute

Copyright American Iron and Steel Institute, 2016

This document is copyrighted by AISI. Any redistribution is prohibited.

PREFACE

This document provides a commentary on the 2016 edition of AISI S310, *North American Standard for the Design of Profiled Steel Diaphragm Panels*, herein referred to as “*Standard*.”

The purpose of the *Commentary* includes: (a) to provide a record of the reasoning behind, and justification for the various provisions of the *Standard* by cross-referencing the published supporting research data, and by discussing the current edition of the *Standard*; (b) to offer a brief but coherent presentation of the characteristics and performance of cold-formed steel *diaphragms* to structural engineers and other interested individuals; (c) to furnish the background material for a study of cold-formed steel *diaphragm* design methods to educators and students; and (d) to provide the needed information to those who will be responsible for future revisions of the *Standard*. Users are encouraged to refer to the original research publications for further information.

Consistent with the *Standard*, the *Commentary* contains a main document, Chapters A through E, and Appendices 1 and 2.

The Committee acknowledges and is grateful for the contributions of the numerous engineers, researchers, producers and others who have contributed to the body of knowledge on the subjects. The Committee particularly acknowledges the pioneering analytical and research work done by Dr. Larry Luttrell of West Virginia University and Clarkson Pinkham of S. B. Barnes Associates. Special thanks are given to the Chairman of the Diaphragm Design Subcommittee, John Mattingly, and Dr. Helen Chen, Secretary of the AISI Committee on Specifications, for their dedication and commitment. The Committee wishes to also express its appreciation for the support of the Steel Deck Institute.

American Iron and Steel Institute
July 2015

SYMBOLS AND DEFINITIONS

The following symbols appear in this *Commentary*. Refer to the list of Symbols and Definitions in the *Standard* for definitions of other symbols.

Symbol	Definition	Section
a	<i>Diaphragm</i> system width subjected to S	Appendix 1.4
B	<i>Diaphragm</i> depth (length parallel with shear force)	C3
C_d	Deflection amplification factor	C1
c_p	Hole center-to-center spacing	Appendix 1.6
D	Dead <i>load</i>	B
D_x	Strong axis flexural <i>stiffness</i> per unit width	D2.1
D_y	Weak axis flexural <i>stiffness</i> per unit length	D2.1
d_p	Perforation hole diameter	Appendix 1.6
I_x	Moment of inertia per unit width	D2.1
I'_x	Moment of inertia of one corrugation (per pitch)	D2.1
L	Live <i>load</i>	B
R	Response modification factor (to seismic <i>load</i>)	C1
V	Shear force delivered along the <i>diaphragm</i> depth, B	C3
V_m	Maximum shear force, V, delivered by the <i>diaphragm</i>	C3
W_d	<i>Load</i> and <i>load</i> distribution causing V_m	C3
S	Average shear level in <i>diaphragm</i>	Appendix 1.4
β_E	<i>Buckling</i> coefficient allowance for end restraint and determined by tests	D2.1
Δ	Differential deflection along <i>diaphragm</i> width, a	Appendix 1.4
Δ_S	Component of Δ caused by material shear displacement	Appendix 1.4
Δ_D	Component of Δ caused by shear relaxation from warping	Appendix 1.4
Δ_C	Component of Δ caused by slip at fasteners	Appendix 1.4
K_{t2}	Spring constant associated with spring constant indicator, κ_{t2}	Appendix 1.4
Ω_o	System overstrength factor	C1

TABLE OF CONTENTS

**COMMENTARY ON THE NORTH AMERICAN STANDARD FOR THE
DESIGN OF PROFILED STEEL DIAPHRAGM PANELS**

Preface.....iii

Symbols and Definitionsiv

List of Tables viii

List of Figures viii

Introduction 1

A. General Provisions2

A1 Scope, Applicability, and Definitions 2

 A1.1 Scope..... 2

 A1.2 Applicability..... 3

 A1.3 Definitions 3

A2 Materials 4

A3 Loads 4

A4 Referenced Documents 4

A5 Units of Symbols and Terms 4

B SAFETY FACTORS AND RESISTANCE FACTORS5

B1 Safety Factors and Resistance Factors of Diaphragm With Steel Supports and No Concrete
 Fill 5

 B1.1 Floor, Roof, or Wall Steel Diaphragm Construction..... 5

C. DIAPHRAGM AND WALL DIAPHRAGM DESIGN8

C1 General..... 8

C2 Strength Design..... 9

C3 Deflection Requirements 9

**D. DIAPHRAGM NOMINAL SHEAR STRENGTH PER UNIT LENGTH AND STIFFNESS DETERMINED
 BY CALCULATION12**

D1 Diaphragm Shear Strength per Unit Length Controlled by Connection Strength, S_{nf} 12

 D1.1 Support Connection Shear Strength in Fluted Deck or Panels, P_{nf} and P_{nfs} 14

 D1.1.1 Arc Spot Welds or Arc Seam Welds on Steel Supports 14

 D1.1.2 Screws Into Steel Supports 15

 D1.1.3 Power-Actuated Fasteners Into Steel Supports 15

 D1.1.4 Fasteners Into Wood Supports..... 16

 D1.1.4.1 Safety Factors and Resistance Factors 16

 D1.1.4.2 Screw or Nail Connection Strength Through Bottom Flat and Into
 Support 16

 D1.1.4.3 Screw or Nail Connection Strength Through Top Flat and Into Support 16

 D1.1.5 Other Connections With Fasteners Into Steel, Wood, or Concrete Support..... 17

 D1.1.6 Support Connection Strength Controlled by Edge Dimension and Rupture..... 18

 D1.2 Side-Lap Connection Shear Strength [Resistance] in Fluted Deck or Panel, P_{ns} 18

 D1.2.1 Arc Spot Welds..... 18

 D1.2.2 Fillet Welds Subject to Longitudinal Shear 19

 D1.2.3 Flare Groove Welds Subject to Longitudinal Shear 19

 D1.2.4 Top Arc Seam Side-Lap Welds Subject to Longitudinal Shear 19

 D1.2.5 Side-Lap Screw Connections 20

D1.2.6 Non-Piercing Button Punch Side-Lap Connections	20
D1.2.7 Other Side-Lap Connections	20
D1.3 Diaphragm Shear Strength per Unit Length Controlled by Support Connection	
Strength Through Insulation, S_{nf}	21
D1.3.1 Lap-Up Condition at Side-Lap	21
D1.3.1.1 Lap-Up Condition With Side-Lap Fasteners Not Into Support	21
D1.3.1.2 Lap-Up Condition With Side-Lap Fasteners Into Support	21
D1.3.2 Lap-Down Condition at Side-Lap	22
D1.3.3 Other Support Fasteners Through Insulation	22
D1.4 Fluted Acoustic Panel With Perforated Elements	22
D1.5 Cellular Deck	22
D1.5.1 Safety Factors and Resistance Factors for Cellular Deck	22
D1.5.2 Connection Strength and Design	22
D1.6 Standing Seam Panels	23
D1.7 Double-Skinned Panels	24
D2 Stability Limit, S_{nb}	24
D2.1 Fluted Panel	24
D2.2 Cellular Deck	26
D3 Shear and Uplift Interaction	27
D3.1 Support Connections	27
D3.1.1 Arc Spot Welds	27
D3.1.2 Screws	27
D3.1.2.1 Screws Into Steel Supports	27
D3.1.2.2 Screws Through Bottom Flats Into Wood Supports	28
D3.1.3 Power-Actuated Fasteners	29
D3.1.4 Nails Through Bottom Flats Into Wood Supports	30
D3.2 Side-Lap Connections	30
D4 Steel Deck Diaphragms With Structural Concrete or Insulating Concrete Fills	30
D4.1 Safety Factors and Resistance Factors	30
D4.2 Structural Concrete-Filled Diaphragms	31
D4.3 Lightweight Insulating Concrete-Filled Diaphragms	31
D4.4 Perimeter Fasteners for Concrete Filled Diaphragms	32
D4.4.1 Steel-Headed Stud Anchors	33
D5 Diaphragm Stiffness	34
D5.1 Stiffness of Fluted Panels	34
D5.1.1 Fluted Panels Without Perforated Elements	34
D5.1.2 Fluted Acoustic Panels With Perforated Elements	35
D5.2 Connection Flexibility	36
D5.2.1 Welds Into Steel	36
D5.2.1.1 Arc Spot or Arc Seam Welds	36
D5.2.1.2 Top Arc Seam Side-Lap Welds	36
D5.2.2 Screws Into Steel	37
D5.2.3 Wood Screws or Nails Into Wood Supports	38
D5.2.4 Power-Actuated Fasteners Into Supports	38
D5.2.5 Non-Piercing Button Punch Fasteners at Steel Panel Side-Laps	38
D5.2.6 Other Fasteners – Flexibility Determined by Tests	38
D5.3 Stiffness of Cellular Deck	38

D5.3.1 Cellular Deck Without Perforations	38
D5.3.2 Cellular Deck With Perforations.....	39
D5.4 Stiffness of Concrete-Filled Diaphragms	39
D5.4.1 Stiffness of Structural Concrete-Filled Diaphragms	39
D5.4.2 Stiffness of Insulating Concrete-Filled Diaphragms	39
D6 Diaphragm Flexibility	40
E. DIAPHRAGM NOMINAL SHEAR STRENGTH [RESISTANCE] PER UNIT LENGTH AND STIFFNESS DETERMINED BY TEST	41
E1 Strength and Stiffness of a Prototype Diaphragm System	41
E1.1 Test Protocol.....	41
E1.2 Design Using Test-Based Analytical Equations	41
E1.2.1 Test Assembly Requirements.....	45
E1.2.2 Test Calibration	47
E1.2.3 Laboratory Testing Reports.....	49
E2 Single Diaphragm System	50
E2.1 Test System Requirements	50
E2.1.1 Fastener and Weld Requirements.....	50
E2.1.2 Concrete Requirements	51
E2.2 Test Calibration.....	51
E2.3 Laboratory Testing Reports	51
E2.4 Adjustment for Design.....	52
E2.4.1 Diaphragms Without Structural Concrete Fill.....	52
E2.4.2 Diaphragms With Structural Concrete Fill.....	52
E2.5 Test Results Interpretation	52
APPENDIX 1: DETERMINATION OF FACTORS, D_N AND γ_c	54
1.1 General.....	54
1.1.1 Scope.....	54
1.1.2 Applicability.....	54
1.2 Determination of Warping Factor, D_N	54
1.3 Determination of Support Factor, γ_c	56
1.4 Determination of Warping Factor Where Insulation is Not Present Beneath the Panel	56
1.5 Determination of Warping Factor Where Insulation is Present Beneath the Panel	57
1.6 Determination of Warping Factor for Perforated Deck	58
APPENDIX 2: STRENGTH AT PERIMETER LOAD DELIVERY POINT	60
REFERENCES.....	61

List of Tables

Table C-E1.2-1 List of Parameters Defined in Common Analytical Methods	44
Table C-1.1a Profile Dimensions (Customary Units in.)	55
Table C-1.1b Profile Dimensions (SI Units mm).....	55
Table C-1.2 D Values	55

List of Figures

Plan View of Simple Building Showing Calculated Diaphragm Deflection at Service Load	10
Figure C-C3-1 Diaphragm Deflection	10
Figure C-D1-2 Interlocking Side-Laps.....	13
Figure C-D1-3 Nestable Side-Lap	13
Figure C-D1.5.2-1 Cellular Deck Interlocking Side-Laps	23
Figure C-D5.1.1-1 Example of Purlin Roll	35
Figure C-D5.1.1-2 Detail to Control Purlin Roll.....	35
Figure C-E2.5-1 Fasteners Required in Multiple-Span Application Based on Single-Span Test of a Single Diaphragm System.....	53
Figure C-1.4-1 Example to Determine D.....	57
Figure C-1.6-1 Example of Perforated Deck With Holes Only in Web.....	58

INTRODUCTION

Cold-formed *panels* have been used successfully in *diaphragms*. These *panels* have fluted profiles and are cold-formed from steel sheet in roll-forming machines or by press brake or bending. *Deck* profiles may be connected to other *deck* profiles or flat bottom plates to form *cellular decks* in the manufacturing plant, and then the *cellular decks* are shipped as assembled units. The *thickness* of steel sheets used in fluted *panels* historically range between 0.014 in. (0.35 mm) and 0.105 in. (2.67 mm). *Cellular decks* are usually formed from thicker sheet steel because of fabrication requirements at longitudinal *connections* and *web* compactness requirements at deeper sections. The steel sheets can be perforated for acoustic, lighting, airflow or other *serviceability* purposes. The *panels* are generally in flat planes but may also be curved in the shop or the field to form arches or shell structures with bending along the *panel* length or across the width. This *diaphragm Standard* only addresses design and testing of plane *diaphragm* systems.

The use of steel *panel diaphragms* has several economic advantages and can reduce the required materials and labor. The *diaphragm* system is usually considered a primary *structural member* that provides lateral resistance and stability to a building system while the *panels* simultaneously provide other *serviceability* functions. The functions include exposed weather-tight membranes (cladding); underlayment (*decking*) for other roofing membranes and insulating systems; concrete forms; permanent reinforcement in *structural concrete* slabs; secondary flexural *structural members* in floors, roofs, or walls; and bracing of primary *structural members*. The *panels* can also replace or supplement permanent diagonal bracing or other bracing systems (Luttrell, 1967).

Industry sponsored much of the original testing of *diaphragms* (Fenestra, Inc., Granco Steel Products Co., H. H. Robertson, R.C. Mahon, Inc., etc.). The testing was performed at or witnessed by independent laboratories, and the focus was to develop *load* tables to assist designers and market products. This work was proprietary and often empirical. Industry testing has continued in order to obtain product evaluation reports. The American Iron and Steel Institute (AISI) has sponsored research in this field since the 1950s. Some of the earliest work was at Cornell University (Nilson, A. H., 1956). AISI-sponsored work continued into the 1960s and 1970s under the direction of Dr. George Winter at Cornell University (Luttrell, 1967). *Diaphragm* applications have history and there is an established and extensive test database (SDI, DDM, 1981, etc.).

Two design manuals were developed for industry and end users, and these manuals have evolved into the primary design and analytical references for designers in North America. These manuals are: (1) Department of Army (1982¹), *Seismic Design for Buildings* (commonly called the *Tri-Services Manual*), based on the work of S. B. Barnes and Associates, John A. Blume and Associates, and Structural Engineers Association of California, first published in 1966; and (2) Steel Deck Institute *Diaphragm Design Manual* (SDI, 2004), based on the work of Dr. L. Luttrell and first published in 1981. Both manuals address flat planar *diaphragm* construction. The limits of design application are established by the tests.

Because these design manuals are not consensus documents, industry petitioned AISI to develop a consensus standard. The first edition of the *North American Standard for the Design of Profiled Steel Diaphragm Panels* (AISI S310-13) was prepared and issued in 2014. Whenever possible, this document is consistent with the edition of AISI S100 and AISI Test Standards referenced in *Standard Section A4*. Provisions outside of the scope of AISI S100 are based on the

¹ The 1982 edition was referenced due to errors in deck design that were found in the 1992 edition.

available research reports. AISI S310 establishes design analytical methods and minimum testing requirements. The first edition of the *Commentary on the North American Standard for the Design of Profiled Steel Diaphragm Panels* was prepared and issued in 2014.

The *Standard* and *Commentary* are intended for use by design professionals with demonstrated engineering competence in their fields.

A. GENERAL PROVISIONS

A1 Scope, Applicability, and Definitions

A1.1 Scope

Diaphragms are roof, floor or other membranes or bracing systems that transfer in-plane forces to the *lateral force-resisting systems*. A *wall diaphragm* can be a *lateral force-resisting system*. The *Standard* provides design provisions for components consisting of *panels* with fluted or *cellular deck* profiles. The *diaphragm* or *wall diaphragm* system includes other components and details that are not explicitly covered in the *Standard*. *Wall diaphragm panels* are in a vertical or nearly vertical plane and often are the *lateral force-resisting system* that transfers forces to foundations. Vertical and horizontal *diaphragms* have nuanced differences and similarities:

- (a) The planar performance is the same but the span-to-depth ratios commonly function over different ranges. Both *diaphragms* resist the same *load* events.
- (b) The wall *dead load* component is one more *load* that might cause *diaphragm* shear or interact with shear. (The *wall diaphragm* normally has a rigid base so wall *dead load* is compressive and not always additive to shear in the *panel* or *support connections* except as a seismic inertial force.)
- (c) Column action in *panels* is treated the same for all *diaphragms* as in Appendix 2.
- (d) The impact of other system components and details is a design issue that must be considered. Three examples are: (1) *purlin* or *girt* roll that inhibits transference of shear to frames, (2) perimeter details that transfer shear from *panels* to *lateral force-resisting systems* or across *panel* discontinuities, and (3) ties in *structural members* that are necessary to collect and transfer axial forces to *lateral force-resisting systems*.
- (e) With proper *connection* details, the interaction of a *wall diaphragm* with a roof *diaphragm* is to unload a roof *diaphragm's* in-plane shear at interior *lateral force-resisting system* lines, or to resist shear at end shear walls. Shear unloads proportionately to the relative *stiffness of the diaphragm and lateral force-resisting system* at those lines and is associated with deflection compatibility. This *wall diaphragm* action is similar to a *moment frame's flexural stiffness* contribution to resisting a roof *diaphragm's* in-plane loads.
- (f) A *wall diaphragm* may be subject to additional requirements in some *applicable building codes*, particularly when the *wall diaphragm* is required for energy dissipation due to seismic load.
- (g) AISI S907 is commonly used to evaluate all *diaphragm* systems.
- (h) *Standard* Table B1.1 applies to walls, roofs, and floors when concrete fill is not present and supports are steel.

The *Standard* is not intended for cold-formed steel framing shear *diaphragms* covered with sheathing other than fluted *panels* or *cellular deck*. Such *diaphragms* should be designed in accordance with AISI S240.

Two design approaches are included in the *Standard*:

- (1) The analytical approach as provided in *Standard* Chapter D, and
- (2) The testing approach as provided in *Standard* Chapter E.

The analytical approach adopts the method presented in the *Diaphragm Design Manual* (Steel Deck Institute, 2004). The method is mechanics-based, confirmed by tests, and includes variations in steel *panel* properties and in *connection* types. Because the analytical method is confirmed by tests, the application limits are established by the tests. The *connection nominal strength* [*resistance*] is determined in accordance with AISI S100 (AISI, 2016) wherever possible. The analytical method adopts the supplemental research sponsored by the Metal Construction Association (MCA) (Luttrell, 1999a) that included insulation between supports and *panels*. The MCA research also addressed wood supports. The testing approach is based on AISI S907-13, *Test Standard for Cantilever Test Method for Cold-Formed Steel Diaphragms* and AISI S905-13, *Test Standard for Cold-Formed Steel Connections*. Both AISI test standards adopt the calibration methods presented in the *Standard* and AISI S100 Section K2.1.1 with modifications applicable to *diaphragms*.

The *Standard* limits itself to the determination of *diaphragm available shear strength* [*factored resistance*] and *stiffness*. However, performance also depends on adherence to design documents and quality control during installation. Guidance in this area is available in the following three references:

Steel Deck Institute (SDI), P.O. Box 426, Glenshaw PA 15116

- (1) ANSI/SDI QA/QC-2011, *Standard for Quality Control and Quality Assurance for Installation of Steel Deck*, 2011
- (2) *Manual of Construction With Steel Deck* (MOC2), August 2006
- (3) *SDI Code of Standard Practice* (COSP), July 2014

A1.2 Applicability

The *Standard* is applicable to *diaphragms*:

- (a) With or without insulation between the *panel* and the support,
- (b) Without insulation between the *cellular deck* and the support in *Standard* Chapter D,
- (c) With insulation between the *cellular deck* and the support in *Standard* Chapter E,
- (d) With or without *structural* or *insulating concrete* fill over the *deck* or *cellular deck*,
- (e) With or without *acoustic* (perforated) *panels* or *cellular deck*, and
- (f) With structural supports made of steel, wood, or *structural concrete*.

This does not preclude other support materials whose performance can be verified by tests or using material design specifications that provide *connection* reliability consistent with the *Standard*. Selection of alternate materials should consider other *serviceability limit state* requirements such as dissimilar materials (corrosion) and fire resistance.

A1.3 Definitions

Definitions for certain commonly used terminologies in *diaphragm* systems are provided in the *Standard*. The *Standard* also refers to the definitions provided in AISI S100 for strength-related terminologies. To apply the *Standard*, the definition of “*diaphragm*” should be in accordance with the *Standard*. Where possible, the definitions in the *Standard* are consistent with the test standards, AISI S905 and AISI S907.

A2 Materials

The materials of profiled steel *panels* should conform to the materials specified in the *Standard*. For low-ductility steels, the *specified yield stress*, F_y , and *specified tensile strength*, F_u , should be modified for design in accordance with AISI S100, Sections A3.1.2 or A3.1.3 for steels not conforming to Section A3.1.1, unless noted otherwise.

Other materials must conform to the national standards governing the design of that material.

A3 Loads

The *required strength* [effect of *factored loads*] in a *diaphragm* system should be calculated using the *load combinations* provided in the *applicable building code*. In the absence of an *applicable building code*, ASCE 7 should be used for ASD and LRFD. Refer to AISI S100 for appropriate building codes for LSD.

A4 Referenced Documents

In addition to the standards referenced in *Standard* Section A4, the following documents may be considered in a calculation-based design approach:

- (a) American Iron and Steel Institute (AISI), 25 Massachusetts Avenue, NW, Suite 800, Washington, DC 20001:

Design Examples for the Design of Profiled Steel Diaphragm Panels Based on AISI S310-13, 2014 Edition

In addition to the standards referenced in *Standard* Section A4, the following documents may be considered in a test-based design approach:

- (a) Department of the Army Seismic Design For Buildings:

Technical Manual TM 5-809-10, 1985 (*Tri-Service Manual*)

- (b) Metal Construction Association (MCA), 4700 W. Lake Ave., Glenview, IL 60025

A Primer on Diaphragm Design, 2004 Edition

- (c) Steel Deck Institute (SDI), P.O. Box 426, Glenshaw PA 15116:

Diaphragm Design Manual, First Edition (DDM01, 1981), and

Diaphragm Design Manual, Third Edition (DDM03, 2004) including Appendices I through VI
Deeper Steel Deck and Cellular Diaphragms, 2005 Edition with Supplement 2013.

These references may be used in conjunction with *Standard* Section E1.2 in determining system effects and application limits of existing test-based methods.

Other references are listed at the end of this *Commentary*.

A5 Units of Symbols and Terms

The equations provided in the *Standard* are intended for design in any compatible system of units (U.S. customary, SI or metric and MKS systems). Equations for U. S. customary and SI or metric unit systems plus the required unit(s) are provided if the *Standard* equation is not compatible with the unit systems. A conversion table between the unit systems is provided in Section A1.4 of the *Commentary* on AISI S100.

B SAFETY FACTORS AND RESISTANCE FACTORS

Standard Table B-1 lists the *Standard* sections that provide the *safety* and *resistance factors* for both calculation and test-based design approaches. A dead to live *load* ratio of zero is used in the development of Table B-1 and in the calibration method of *Standard* Chapter E. Because of the nearly horizontal condition in floors and roofs, shear due to vertical *load* is perpendicular to the *load effects* causing *diaphragm* shear. In walls, the vertical *load* normally induces compression in the *panels* and little shear into the *connections*. As such, vertical *load* shear rarely adds to the in-plane shear *stresses* in the *panels* or the shear in the *connections* of *diaphragms* or *wall diaphragms*. *Connections* commonly control *diaphragm resistance*. The assumption of $D/L = 0.0$ is slightly more severe than the assumption of $D/L = 0.2$ for *LRFD* or $D/L = 0.33$ for *LSD* in AISI S100 Section K2.1.1. Since the dead *load* of the *diaphragm* was present in the tests for confirmation of the analytical method, inclusion of dead *load* is partly built into the calibration.

B1 Safety Factors and Resistance Factors of Diaphragm With Steel Supports and No Concrete Fill

The *safety* and *resistance factors* provided in the 2013 edition of *Standard* Section B1 were extracted from the 2012 edition of AISI S100 Section D5. In 2016, those *safety* and *resistance factors* were moved to this *Standard*, updated and included in *Standard* Table B1.1. Refer to Section B1.1 for background information. The *Standard* Table B1.1 *safety* and *resistance factors* determine the *diaphragm available strength* [*factored resistance*] where the *nominal strength* [*resistance*] is determined in accordance with *Standard* Chapter D. The *safety* and *resistance factors* determined in accordance with *Standard* Chapter E are limited by those in *Standard* Table B1.1 unless noted otherwise in the *Standard*. The table distinguishes material-related limits and *connection*-related limits. The table also distinguishes different *loads* that cause the *diaphragm* shear.

B1.1 Floor, Roof, or Wall Steel Diaphragm Construction

The structural performance of a *diaphragm* can be evaluated by either calculations or tests. Several analytical procedures exist, and are summarized in the *Commentary* Sections A4 and E1.2. Analytical methods consider the limit states of the *connections* between the panels, and between the panels and structural supports, as well as the support thickness and its mechanical properties. As an example, the tilting of screws discussed in AISI S100 Section J4.3 is different from the bearing capacity controlled by panels. The analytical methods will then determine the capacity of the *diaphragm* based on the limit states. Yu and LaBoube (2010) provide a general discussion of structural *diaphragm* behavior.

AISI S907, *Test Standard for Cantilever Test Method for Cold-Formed Steel Diaphragms*, provides the test procedures and commentary for cold-formed steel *diaphragms*. Historically, tested performance was measured using the procedures of ASTM E455, *Standard Method for Static Load Testing of Framed Floor, Roof and Wall Diaphragm Construction for Buildings*, and those results are valid. Future researchers using ASTM E455 should match the minimum number of panels required by AISI S907 over the shear field unless that number is not representative of the design application.

Table D5 in AISI S100-12 was based on a calibration of test data in DDM01 (SDI, 1981). The test data in DDM01 includes welds, screws, some proprietary *power actuated fasteners* and the interaction of all *support* and *side-lap connections* (i.e. system effects). The DDM01 statistical values are:

Diaphragm Connection Type	n	P_m	V_p
Welds	107	1.151	0.217
Screws	29	1.038	0.128

The SDI calibration was based on the same theory as the *Standard* but the test-based *connection* strengths differ from those in AISI S100 and in the *Standard*. The *safety factors* and *resistance factors* listed in *Standard* Table B1.1 are obtained through a recalibration of an expanded database of full-scale *diaphragm* tests. The weld test data now includes: SDI (1981), Ellifritt (1970), and Bagwell (2008); and the screw test data includes: SDI (1981), Luttrell (1967), MCA (1999), and Bagwell (2008). The recalibration used the method of AISI S100-C Section B3.2.2 and AISI S100 Section K2.1.1 and the *load factors* in ASCE 7-10. AISI S100-C Section B3.2.2 only addresses the dead plus live load combination, which leads to the suggested factors of $C_\phi = 1.52$ and $V_Q = 0.21$ for members and individual connections – See the AISI S100-C Section B3.2.2 for background information. It is common for wind or seismic events to control the *required diaphragm strength* [effect of factored loads]. The recalibration is also consistent with the *connection strength* equations in *Standard* Section D1 and the provisions of *Standard* Section E1.2.2. The statistical factors in the recalibration are:

LRFD Calibration Factors for Diaphragms										
Connection Type	C_ϕ	V_Q	M_m	V_M	F_m	V_F	V_p	n	C_p	P_m
Welds	1.6	0.25	1.10	0.10	1	0.10	0.188	88	1.035	1.008
Screws				0.08		0.05	0.145	61	1.051	1.162

Note: The *LSD* calibration factors are the same except $C_\phi = 1.5$.

The most probable *diaphragm D/L load* ratio is zero. This results in the values given in *Standard* Section E1.2.2, $C_\phi = 1.60$ and $V_Q = 0.25$. The dominant *diaphragm* limit state is *connection-related*. Consistent with AISI S100 and explained in AISI S100-C Section B3.3.2(b), in the United States and Mexico, the calibration used $\beta_o = 3.5$ for all *load effects* except for wind *load* and allowed $\beta_o = 2.5$ for *connections* subjected to wind *loads*; in Canada, the recalibration used $\beta_o = 4.0$ for all *load effects* except wind *load* and used $\beta_o = 3.0$ for *connections* subjected to wind *loads*. These reliability indices are required by AISI S100 for individual *connections* with the exception of $\beta_o = 3.0$ in *LSD*, which is for a member. These individual reliability indices are applied in the *diaphragm* tests where all the *connections* are loaded. This approach is historical and conservative because of the repetition of *connections* and potential load redistribution in the *diaphragm* system. Based on the expanded test database and the *connection strengths* [*resistances*] given in this *Standard*, the *safety factors* and *resistance factors* listed in *Standard* Table B1.1 changed relative to those in the 2013 edition of AISI S310. The increased number of screw *diaphragm* tests shows greater reliability relative to welds in *Standard* Table B1.1. Using $\beta_o = 2.5$ for screw calibration suggests that the *safety* and *resistance factors* for *connections* are less severe than the *safety* and *resistance factors* for *panel buckling*, $\phi = 0.8$ and $\Omega = 2.0$. However, *connection-controlled diaphragm safety* and *resistance factors* are not permitted to be less severe than member-controlled *diaphragms* (*panel buckling*) in

Standard Table B1.1. $\phi_d = 0.70$ and $\Omega_d = 2.35$, that were included in Table D5 of AISI S100-12 for wind, are eliminated in *Standard* Table B1.1 for *connection-controlled diaphragms*. These *safety* and *resistance factors* were intended to keep the service load close to the test point, $0.4P_{ultimate}$, for *stiffness* determination. Since the stiffness is relatively constant in this service load zone, the recalibration allowed the method of *Standard* Section E1.2.2 to stand alone.

The calibration of resistance to seismic loads is based on a load factor of 1.6, which might be more conservative than required by ASCE 7. The impact of seismic events on V_Q requires further study. No distinction is made between seismic load and other loads in the recalibration. This differs from earlier editions of the *Standard* and AISI S100 where *safety* and *resistance factors* for welding varied. However, with the exception of LSD, no change occurred for seismic load at welds relative to AISI S100-12 Table D5. When the load factor for earthquake loading is one, the 0.7 multiplier of ASCE 7 is allowed in ASD and the *safety factors* of *Standard* Table B1.1 should be applicable. If a local building code requires that a load factor of 1.6 be applied to the seismic load, the factors of *Standard* Table B1.1 should still be applicable.

The Steel Deck Institute (1987) and the Department of Army (1985) have consistently recommended a *safety factor* of 2.0 to limit “out-of-plane buckling” of *diaphragms*. Out-of-plane buckling is related to panel profile, while the other *diaphragm* limit state is *connection-related*. The remainder of the *Standard* and AISI S100 require different *safety* and *resistance factors* for the two limit states and larger *safety factors* for *connection-controlled* limit. The prescribed factors for out-of-plane panel buckling are constants for all loading types.

The *Standard* allows mechanical fasteners other than screws to be used in accordance with *Standard* Section D1.1.5 or D1.2.7, as applicable. The *diaphragm* shear value using any fastener must not be based on a *safety factor* less than the *safety factor* of individual fastener shear strength or a *resistance factor* greater than the *resistance factor* of individual fastener shear strength unless: 1) sufficient data exists to establish a system effect, 2) an analytical method is established from the tests, and 3) test limits are stated. The system effect is established through large-scale tests in accordance with AISI S907.

C. DIAPHRAGM AND WALL DIAPHRAGM DESIGN

Standard Chapter C is used to determine the *available shear strength* [factored resistance] per unit length and *stiffness* or *flexibility* of *panels* as *diaphragm* system components, and to compare these values with the *required shear strength* [shear force due to factored loads] and required *stiffness*. This *Standard* includes design of *panel* and support *connections*. Since the *diaphragm* resistance also includes the ability to transfer *loads* into the *diaphragm* and transfer *loads* out at either *shear walls* or at braced bents or rigid frames, this *Standard* includes those connections and details. The design of components and details not included in this *Standard* should be based on other standards. The following are the latest edition of the most commonly used standards:

- (a) Hot Rolled Steel Structural Members: ANSI/AISC 360-10
- (b) Cold-Formed Steel Structural Members: AISI S100-16
- (c) Structural Concrete Members: ACI 318-11
- (d) Wood Structural Members: ANSI/AWC NDS-2012

Design must consider *serviceability limits* such as acceptable drift or the appearance of buckled shapes at *service loads* in some products. *Local buckling* or oil canning is common in cold-formed steel products and post-buckling strength is counted on in design. Such *buckling* or waves are not always a *serviceability* or cosmetic issue.

C1 General

The *diaphragm* and *wall diaphragm* systems transfer the forces through the chords and collectors to the *panels* that act as a *stressed* shear transfer skin. The *stressed* skin is attached to the *panel's* supports in the field and at the edges of the *diaphragm* or *wall diaphragm* system. The *Standard* provides design equations that can be used to determine the in-plane shear *resistance* of the *panels* of the *diaphragm* and *wall diaphragm*, and the shear resistance of *connections* between *panels* and between *panels* and *supports*.

Wall diaphragm (*shear wall*) applications subject to seismic *loading* are dependent on the seismic system coefficients for the wall system. ASCE 7-10 does not provide specific requirements for the use of fluted sheet steel *panels* for *wall diaphragm* construction. Where the fluted sheet steel *wall diaphragm's* seismic design coefficients are not otherwise recognized by the building official, the *wall diaphragm* may be classified as a light-framed wall with shear resisting *panels* under the all other materials provision in accordance with ASCE 7 (ASCE, 2010) Table 12.14-1 Item A15, which specifies a response modification factor, $R = 2$. This is lower than the response modification coefficient specified at Item A16 for light-framed (cold-formed steel) wall systems using flat strap bracing, $R = 4$, which is an inherently less ductile system than steel sheets in *wall diaphragms* (*shear walls*). Fluted sheet steel *panels* have characteristics similar to flat sheet *panels* because the *nominal strength* [*resistance*] and ductility are associated with the *connections* at the support framing and not the shape of the *panel* or the support framing, particularly when each flute is attached to the supports. Stojadinovic and Tipping (2008) demonstrated this through cyclic tests of corrugated sheet steel *panels* attached to cold-formed steel framing with self-drilling screws. The study found that following ATC 63, the seismic system coefficient, R , would be in the range of 3 to 4. However, much higher coefficients are recommended based on the 90% draft of FEMA P-795. Stojadinovic and Tipping recommend the following seismic system coefficients: (a) Response Modification Factor, $R = 5.5$, (b) System Overstrength Factor, $\Omega_o = 2.5$, and (c) Deflection Amplification Factor, $C_d = 3.25$.

C2 Strength Design

A *diaphragm* system can be designed using *ASD* or *LRFD* in the U. S. and Mexico, and *LSD* in Canada. Information regarding these design methods can be found in Section B3.3 of the *Commentary* on AISI S100. Information regarding *loads* and *load combinations* can be found in Section B2 of the *Commentary* on AISI S100. For *ASD*, the *Standard* requires that the *diaphragm panel system safety factor* be applied to the *diaphragm's nominal shear strength [resistance]* per unit length in Eq. C2-1. Since the *diaphragm nominal shear strength [resistance]* depends on the *support* and *side-lap connection nominal shear strengths [resistance]*, most *Standard* sections only present the *connection nominal shear strength [resistance]*. The exception is the shear and uplift interaction that allows determination of the *nominal connection shear strength [resistance]* using either *ASD*, *LRFD*, or *LSD* since interaction is related to the *required strength [force due to factored loads]* in tension.

C3 Deflection Requirements

A *diaphragm* should be stiff enough so that δ_n is less than or equal to δ_a . Deflection, δ_n , is the total (shear plus flexural) deflection component of the *diaphragm*. Deflection can be determined by *structural analysis*, and several design examples are shown in the supplemental references listed in the *Commentary* in Section A4. For many *diaphragm* designs, the contribution of longitudinal strain in the perimeter members and the flexural deflection of the *diaphragm* are negligible when compared to the contribution of shear deflection, particularly when the accuracy of predicting *diaphragm stiffness, G'*, is considered. This simplifies *analysis* but it is always permissible to consider both deflection components.

where

δ_n = Theoretical *diaphragm* deflection at *service load* or *nominal loads [specified loads]*

δ_a = Allowable *diaphragm* deflection defined by the *applicable building code* and the structure's service requirements

The change in shear deflection between two points along the *diaphragm* span can be determined by calculating the area under the $\frac{V}{G'B}$ diagram between those points. However, this principle should be applied with caution when *G'* varies along the *diaphragm* span, L_d (L_d is shown in Figure C-C3-1). When *G'* varies, an energy method should be used to determine the in-plane deflection.

Figure C-C3-1 shows potential *diaphragm* deflection for a simple rectangular *diaphragm* under symmetric *loading*. This is idealized, but is a common event. Deflection can include longitudinal deformation of support members plus racking and twisting of end walls and interior frames. This example has braced end walls and sidewalls so the *shear walls* are relatively rigid in plane when compared to the *diaphragm stiffness*. In this example, since the interior frames provide minimal deflection resistance, they do not unload the *diaphragm* and reduce *diaphragm* deflection and shear. A *diaphragm* can be considered as a deep beam in which shear deformation is dominant since the *diaphragm* has a small span-to-depth ratio, $\frac{L_d}{B}$. Usually *diaphragm stiffness, G'*, is significantly less than the *flexural stiffness* of the deep beam for the structure and the flexural component is often neglected in design. Some *applicable building codes* require both the *diaphragm* $\frac{L_d}{B}$ ratio to be limited to a certain value, and *lateral force-resisting*

system stiffness to be considered when the *diaphragm stiffness*, G' , is within a certain range. The design engineer should satisfy these code requirements.

Where a *diaphragm* is not stiff relative to the *lateral force-resisting system* stiffness, the reaction line support approaches a rigid support and the *diaphragm* acts as a simple beam between rigid supports.

Where the interior frames are *moment frames* and the *connection* detail allows development of in-plane deflection resistance or the end wall is not relatively rigid, *lateral force-resisting system* deflections will affect *load* sharing and theoretical *diaphragm* deflection, δ_n . Design is commonly based on deflection compatibility between *shear walls*, frames and *diaphragms*. A *stiffness analysis* might be required to determine the shear distribution to each frame or end wall.

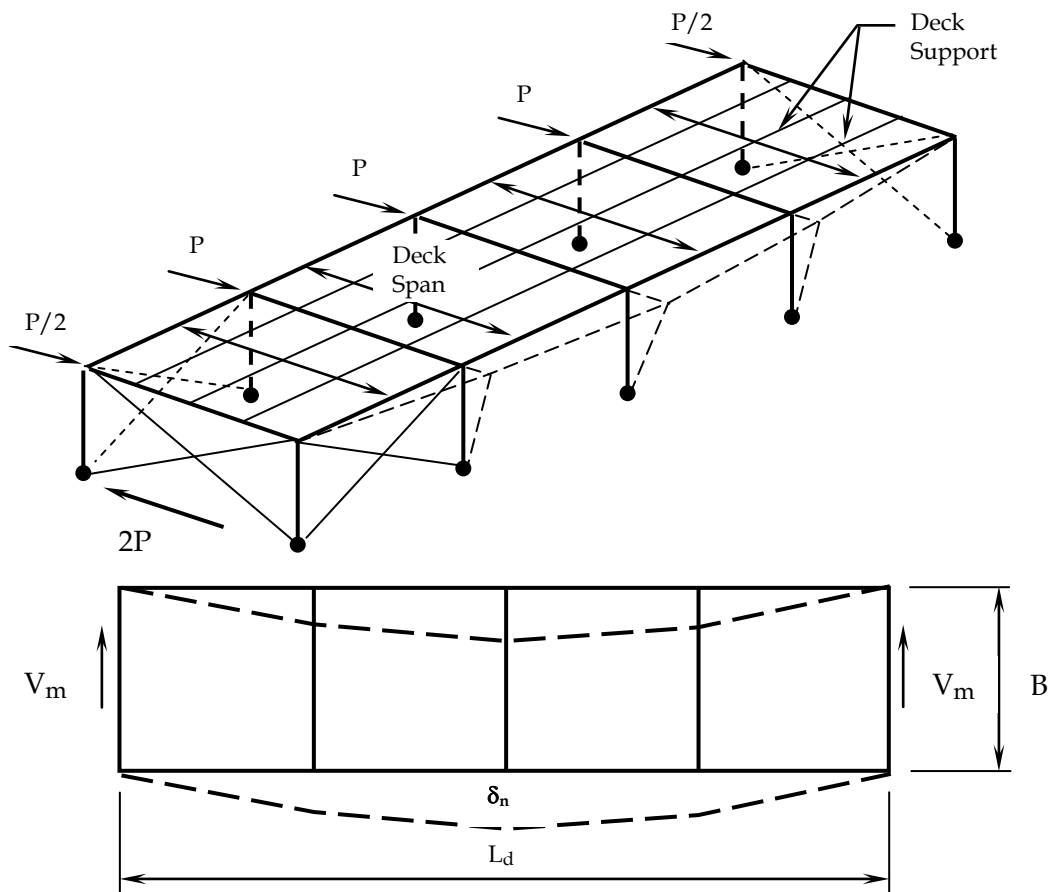

Plan View of Simple Building Showing Calculated Diaphragm Deflection at Service Load

Figure C-C3-1 Diaphragm Deflection

The *diaphragm* deflection is a function of the primary parameters as shown below:

$$\delta_n = \delta \left(V_m, B, L_d, \frac{1}{G'} \text{ or } F, W_d \right) \quad (\text{C-C3-1})$$

where

V_m = Maximum shear force, V , delivered by the *diaphragm*

B = *Diaphragm* depth (length parallel with shear force)

L_d = *Diaphragm* span between *shear walls* or reaction lines

G' = *Diaphragm* stiffness

F = *Diaphragm* flexibility

W_d = *Load* and *load* distribution causing V_m

δ = Deflection function symbol

Figure C-C3-1 provides one example of W_d where equal *loads*, P , are being applied in line with the frames. This might happen where *girts* deliver wind *loads* to frame columns. The resultant shear per unit length in the roof *diaphragm panel* is: $\frac{V_m}{B} = \frac{1.5P}{B}$ while the end wall

resists $\frac{2P}{B}$. $\frac{V_m}{B}$ is the *required shear* per unit length in the *diaphragm edge panel*.

D. DIAPHRAGM NOMINAL SHEAR STRENGTH PER UNIT LENGTH AND STIFFNESS DETERMINED BY CALCULATION

The *Standard* section is applicable to fluted *panels* or *deck* with depth equal to or less than 7.5 in. (191 mm). The stated limits reflect the research by Luttrell (SDI, 1981) and Luttrell (1999a), and Bagwell and Easterling (2008). The *thickness* limit of 0.075 in. (1.91 mm) reflects industry practice and the total *thickness* tested by Bagwell and Easterling. This is a slight increase relative to the 0.064 in. (1.63 mm) limit reported in SDI DDM03 (2004).

Standard Chapter D provides design provisions to calculate the *diaphragm nominal shear strength [resistance]*, *stiffness* and *flexibility*. The *diaphragm nominal strength [resistance]* calculated in accordance with *Standard* Chapter D is the minimum of the three following *limit states of nominal shear strength [resistance]* per unit length:

- (1) *Connection nominal strengths [resistance]* at the *interior* and *exterior supports* in each *panel*, and the *corner connection nominal strength [resistance]* in each *panel* (addressed in *Standard* Section D1);
- (2) *Diaphragm out-of-plane buckling strength* (addressed in *Standard* Section D2); and
- (3) *Diaphragm support connection nominal strength [resistance]* at *edge panels* over *shear walls*, *reaction line frames*, or *collection struts* (addressed in *Standard* Section D1).

Connection-controlled diaphragm nominal shear strength [resistance] is due to local failure at *connections* either by *bearing* of the *panel* against the fastener, by *bearing* or *pull-out* at supports, or by *shear failure* in the fastener body while the profile remains relatively intact. Redistribution is normally present in *connection* forces until system ultimate load occurs. The *panel* often performs elastically and reclaims its original shape upon unloading after *connection* failure.

The *diaphragm nominal shear strength [resistance]* due to *shear buckling* is controlled by:

- (a) Total *out-of-plane panel buckling* with limited *connection* failure, or
- (b) Significant development of *panel waves* and *tension field action* with redistribution of *connection* forces and subsequent *connection* or fastener failures.

The analytical approach outlined in *Standard* Chapter D is based on the third edition of the *Diaphragm Design Manual* (SDI DDM03, 2004) and is virtually the same as that of SDI DDM01 (1981). Design examples are provided in SDI DDM03 (2004) and AISI Design Guide (2014). The method includes the additive and independent contribution of *support connections* and *side-lap connections* as the system effect. The contribution of *support connections* varies linearly with distance from the center of the *panel*.

D1 Diaphragm Shear Strength per Unit Length Controlled by Connection Strength, S_{nf}

The *diaphragm nominal shear strength [resistance]* per unit length controlled by *connection nominal strengths [resistance]* in each *panel* includes fastener failure or *connection* failure in the *panel*. *Standard* Eq. D1-1 includes a $(\lambda-1)$ relaxation term, which represents edge of *panel* corner buckling at *support connections* along *side-laps* at *panel* ends. That corner *connection* cannot develop its full *nominal strength [resistance]*. This relaxation occurs at the compression corners as the *panel* racks in-plane but the reduction is applied in both directions (tension and compression) for simplicity. *Standard* Eq. D1-2 recognizes the orthogonal force components and greater demand at the corner *connections* in each *panel* as illustrated in *Standard* Appendix 2 Figure 2.2-1, which is showing a particular *panel* at the *diaphragm* edge and not the general case at *interior panels* (in the general case, w_a or w_u are not present).

The *diaphragm nominal shear strength [resistance]* controlled by *connections at edge panels* includes fastener failure or local *panel* failure at fasteners along lines where the shear is transmitted from the *diaphragm* to the structure's *lateral force-resisting system* (*shear walls, braced bents, or moment frames*). These *connections* are spaced parallel to the *panel*, and typically edge supports are required in the shear transfer plane to allow installation of these edge *connections*. *Standard* Eq. D1-3 addresses this *diaphragm* strength limit, and the *required strength [reaction due to factored loads]* at frames is compared with this *available shear strength [factored resistance]*. It should be noted that the reaction at an interior support usually does not equal the shear in the *diaphragm panel* at the point of transfer, as beam reactions do not equal shear at interior reactions.

Standard Eq. D1-3, S_{ne} includes the contribution of all edge fasteners, n_e , and the *support connections* between the *panel* center line and the reaction line in the *edge panel*. *Standard* Eq. D1-3 is based on a symmetric *connection* pattern at each support in an *edge panel*, while the patterns can vary between *interior* and *exterior* supports. It is acceptable to only consider n_e and the *support connections* at the edge by letting $\alpha_1 = 1$ and $\alpha_2 = 1$ in *Standard* Eq. D1-3. Since adding *connections* at the edge parallel with the *panel* span normally does not significantly impact installation time, many designers will not let S_{ne} control *diaphragm* capacity. Common practice requires n_e to equal or exceed n_s .

Standard Figure D1-1 assumes that a common *support connection* occurs at the *side-lap* and that the *panel* ends are lapped. In *Standard* Figure D1-1, N = the *connections/unit width*. For a cover width, w , = 3 ft (0.914 m), $A = 2$ and $N = 5/3$ (1/ft) (5.47 (1/m)) at the top *exterior support*, while $A = 1$ and $N = 4/3$ (1/ft) (4.38 (1/m)) at the bottom *exterior support*. If a fastener is installed at either side of the side-lap (See Figure C-D1-2), then with everything else being equal, N at the top is $7/3$ (1/ft) (7.64 (1/m)) and N at the bottom is $5/3$ (1/ft) (5.47 (1/m)). In either case, when determining α_e and α_e^2 , there are 7 values of x_e at the top and 5 values of x_e at the bottom.

In the *Standard* Figure D1-1, the number of *side-lap connections*, n_s , is 6 and is distributed over the entire *panel* length, L . Note that n_s is not the number of *side-lap connections* per span, L_v . The number of *side-lap connections*, n_e , at the edge (*lateral force-resisting system* line in the schematic) is 9. The schematic in *Standard* Figure D1-1 conforms to common practice, $n_e \geq n_s$.

The terms, *exterior support* and *interior support*, are relative to each *panel* and not descriptive of the location within the structure.

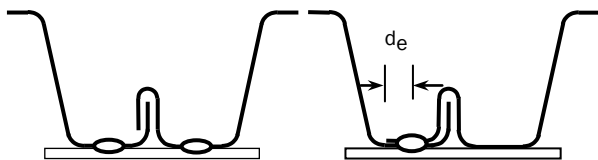

Figure C-D1-2 Interlocking Side-Laps

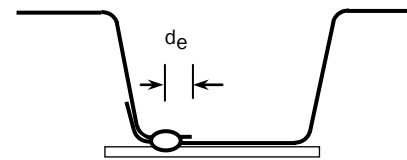

Figure C-D1-3 Nestable Side-Lap

A *support connection* should be installed at either side of the *side-lap* when the *panel* design does not allow a single *support connection* to engage both sections of *panel* at the *side-lap* while developing full *nominal strength [resistance]*. Figure C-D1-2 shows examples of *interlocking side-lap connection* over an *interior support*; one option requires two *support connections* while the other may allow one. The critical edge dimension, d_e , is shown for the second option. Figure C-D1-3

shows that d_e is also critical at nestable *side-laps*. If the horizontal lip is too short, an arc spot weld might not be acceptable but an erector might use an equivalent *strength* fillet weld or a mechanical fastener to engage the support. The designer should determine equivalence.

It is possible to have multiple *connections* in each flute over any support and that effect is included in α_1 and α_2 in Eq. D1-3, and α_e^2 and α_p^2 in Eq. D1-5, respectively. The term “A” in *Standard* Eq. D1-1 accounts for the reduced corner *connection resistance* as limited by the compressive *stiffness* of the *panel* at the *side-lap* over the support. With multiple fasteners per flute, proper spacing and edge dimension must be maintained and the group effect might become a *limit state* at the fastener cluster. See *Standard* Section D1.1.6.

Standard Equations D1-1 through D1-11 were developed by Luttrell and first published in *The SDI Diaphragm Design Manual*, First Edition (SDI, 1981). They are also listed in SDI DDM03 (SDI, 2004). The *Standard* equations are based on fluted *panels* with the *configuration* illustrated in *Standard* Figure D2.1-1 and parameters shown in *Standard* Figure D1-1 and defined in *Standard* Section D1. The basic *Standard* equations and the mechanical model can be modified to be applicable to *diaphragms* with concrete fill over *deck* or with insulation between the *panel* and the support. The *Standard* applies such modifications in Sections D1.3 and D4. The modifications consider the potential for corner *buckling* and end warping, and the relative *flexibilities* of *support connections*.

D1.1 Support Connection Shear Strength in Fluted Deck or Panels, P_{nf} and P_{nfs}

The *Standard* permits the *nominal strength* [*resistance*] of *connections* to be determined either by calculation or by tests.

Standard Sections D1.1.1 through D1.1.4 contain provisions to calculate *support connection strength*, P_{nf} or P_{nfs} , at *diaphragm connections* whose *strength* is listed in AISI S100 or defined by the referenced research reports. *Standard* Section D1.1.5 contains provisions to test *support connection strength*, P_{nf} or P_{nfs} , for unlisted fasteners into steel or wood supports. All fasteners into concrete supports should be tested in accordance with Section D1.1.5. *Standard* Section D1.1.6 addresses *connection strength* controlled by edge dimensions of panel for individual *connections* and at critical shear planes for *connection* groups.

The ductility provisions of AISI S100 Section A3.1 should be considered in *Standard* Chapter D. For example, to use ASTM A653 SS Grade 80 steel *panels*, the reduced *yield stress*, $F_y = 60$ ksi (415 MPa), and reduced *tensile strength*, $F_u = 62$ ksi (430 MPa), should be used to calculate *connection strength* in accordance with AISI S100 Section A3.1, unless noted otherwise.

D1.1.1 Arc Spot Welds or Arc Seam Welds on Steel Supports

The *nominal strengths* [*resistance*] of arc spot welds and arc seam welds on steel supports are extracted from AISI S100 Section J2.2.2.1 and Section J2.3.2.1. See the corresponding sections of the *Commentary* in AISI S100 for technical background information.

Weld washers typically are required at supports when the *panel thickness* is less than 0.028 in. (0.71 mm).

The *thickness* of supports can contribute to blowholes where *panels* are welded to supports. A rule of thumb is that the support should be at least 1/8 in. thick, but this does not always prevent blowholes. AISI S100 Section J2.2 sets 0.15 in. (3.81 mm) as a lower limit

for a support. If blowholes caused by arc spot or arc seam welds into thin support material are a structural or cosmetic concern, fasteners should be considered as an alternative. A blowhole may become a structural concern when a significant amount of the support flange area is removed. Some blowholes should be expected at welded *side-lap connections* between supports.

Arc seam welds are often used in narrow flutes where it is difficult to achieve 1/2 in. (12.7 mm) diameter arc spot welds. The weld width must be sufficient to achieve adequate fusion at the support.

Welding through multiple *thicknesses* requires field quality control. It can be difficult to weld through multiple *thicknesses* of steel sheet, particularly through four layers of *thickness* (Snow and Easterling, 2008). However, it is possible to provide adequate welds through four *thicknesses* as long as the welder adheres to certain requirements. Quality depends on electrode choice (both size and type), weld settings, welding time, air gaps, ambient conditions, presence of moisture, support *thickness* (sometimes), and the skill of the welder (Guenfoud et al, 2010). Guenfoud reported that welding is possible if the support *thickness* exceeds 70% of the combined *thickness(es)* to be welded. Welding can be difficult when the support *thickness* is less than 50% of the combined *thickness(es)*. The *panel* manufacturer might recommend that four layer laps be avoided if the *thickness* of one element at the four-layer lap exceeds 0.06 in. (1.5 mm). In addition, nestability is a concern in thicker *panels* or *panels* with steep *webs* since air gaps contribute to welding difficulty.

A fastener *connection* should be considered if consistent welding quality is difficult to maintain. Figure C-D1.1.1-1 shows common four-*thickness* laps that might occur at *side-laps* or in an end-lap. Minimum edge dimensions must be maintained at welds or mechanical fasteners.

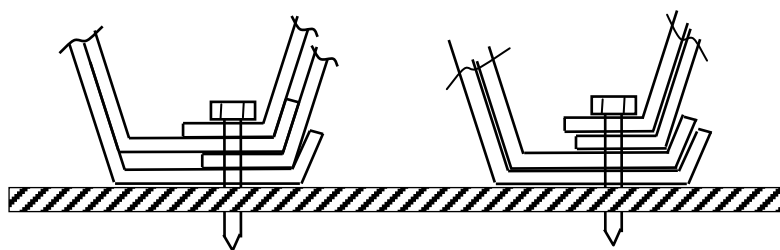

Figure C-D1.1.1-1 Examples of Connection With Four Thicknesses

D1.1.2 Screws Into Steel Supports

The design provisions of *Standard* Section D1.1.2 are extracted from AISI S100 Section J4.3.1. The technical background information can be found in Section J4 of the *Commentary* to AISI S100. To ensure the required level of performance in structural applications, designers should specify screws that conform to ASTM C1513 or an equivalent standard.

D1.1.3 Power-Actuated Fasteners Into Steel Supports

The *Standard* requires that the *nominal strengths* [*resistances*] of *power-actuated fasteners* (PAF) be determined by tests. The tests should also set the *PAF* application limits. A designer can find the test-based strength and *connection flexibility* equations for specific *power-actuated fasteners* listed in SDI DDM03 (2004) and its appendices or can consult the

fastener manufacturer for test data on these and other *PAF* fasteners. The *PAF* used in design should be specified and no substitution of other *PAFs* should be permitted unless the substituted fasteners are equivalent in strength and *connection flexibility* to the specified *PAF*. The designer should request data for replacement of proprietary *PAF* fasteners to substantiate the design values and conformance to the *Standard*.

Tilting should be considered in fastener selection and *strength* determination. The equations given in SDI DDM03 (2004) indicate the acceptable panel thickness and support thickness ranges. The application limits for each equation as listed in SDI DDM03 (2004) or provided by the manufacturer should be met for each particular fastener type.

D1.1.4 Fasteners Into Wood Supports

D1.1.4.1 Safety Factors and Resistance Factors

Because of uncertainty over the material factors in wood, a limiting *safety* and *resistance factor* is imposed even when the test-based calibration may indicate less severe *factors*. The limiting *factors* are consistent with the calibration in Luttrell and Mattingly (2004).

D1.1.4.2 Screw or Nail Connection Strength Through Bottom Flat and Into Support

The *Standard* equations for determining fastener *nominal strength* [*resistance*] into a wood support, P_{nfw} , are from AWC NDS (1986) as listed in the MCA research by Luttrell (1999a). Small-scale tests can be waived for other fasteners that are not listed in *Standard* Table D1.1.4.2-1 as long as their strengths are taken from AWC NDS (2012) and the *safety* or *resistance factors* corresponding to those strengths are less severe than those in *Standard* Section D1.1.4.1. Otherwise, testing is required in accordance with *Standard* Section D1.1.5. The principle for adopting new fasteners in the analytical method is that confidence in the fastener strength must be as good as the ability to predict system strength.

The interior support fastener shank is subject to single shear, while the end-lap fastener shank is subject to double shear. With the exception of the shank, the *fasteners* at the end-laps are subjected to lower shear stress at service *load* as compared to *fasteners* at interior support since the interior support usually has larger *load* tributary area than the end support. As shear flows from the panel to the fastener, each ply sees single thickness bearing against the fastener, so an end-lap ply sees one-half the force that an interior support sees. At *nominal load*, each *support connection* along a side-lap or *side-lap connection* resists as much as it can due to redistribution. Because of this, many manufacturers may use P_{nf} that is based on the single *panel thickness* (t_1) for both interior and end-lap *connections* in both single- and multiple-span tables.

D1.1.4.3 Screw or Nail Connection Strength Through Top Flat and Into Support

Fastener *nominal strength* [*resistance*] through top flats at interior corrugations is neglected due to the *connection flexibility* caused by the cantilever action of the fastener where the fastener only *bears* on the *panel* at the top. Since the opposing shear motion at *side-laps* limits this *support* fastener from tilting, the fastener contribution is included at *side-laps*.

P_{nf} at this condition is based on one *thickness*. Generally, the steel sheets at the *side-lap* have the same *thickness*. If the *thickness* of the two sheets is different, P_{nf} should be based on the *thickness* of the thinner sheet since the thinner sheet controls the *bearing*.

The *connection* provisions provided in *Standard* Section D1.1.4.3 are based on two possible *limit states*: (1) the fastener *bearing nominal strength [resistance]* in the wood support, and (2) the fastener *bearing nominal strength [resistance]* against the steel *panel*. The *nominal shear strengths [resistance]* of fully penetrated fasteners, P'_{nf} , are obtained from the National Design Specification (AWC, 1986) as reported by Luttrell (1999a), while the *bearing strength* against a steel *panel*, P_{ns} , is discussed in *Commentary* Section D1.2.5 and is based on AISI S100 (AISI, 2016). Screw *bearing* against the *panel* equals the *side-lap connection shear strength* determined using AISI S100 Equation J4.3.1-2 and J4.3.1-3 in *Standard* Section D1.1.2. The *connection* is not stronger than the fastener breaking *shear strength*.

D1.1.5 Other Connections With Fasteners Into Steel, Wood, or Concrete Support

The *nominal shear strength [resistance]* of a *diaphragm* fastener into a concrete support must be tested. Similarly, a fastener into a wood support must be tested if the fastener is not listed in *Standard* Section D1.1.4. AISI S905 should be used to determine the fastener *nominal strength [resistance]* and the *connection flexibility*. Alternative ASTM test standards are acceptable in *Standard* Section E1.1 for *nominal strength [resistance]* determination of fasteners into non-steel supports. However, calibration should be in accordance with *Standard* Section E1.2.2.

If the *diaphragm* system satisfies the requirements defined in *Standard* Chapter D, the design provisions provided in *Standard* Sections D1 and D2 can be used to determine the *diaphragm nominal shear strengths [resistance]* per unit length controlled by *diaphragm* interior, corner, and edge *connections* as well as controlled by *diaphragm out-of-plane buckling*. Only small-scale tests are needed to determine *diaphragm nominal shear strength [resistance]* that is controlled by *support connection* strength and to determine *diaphragm stiffness* related to *connection flexibility*. However, the reliability of *connection* strength determined by small-scale tests must be consistent with the system requirements in *Standard* Table B-1.

Support connection performance depends on the thickness, *tensile strength* and hardness of the support. For two examples: (1) the tilting resistance of screws depends on the support thickness; and (2) *power-actuated fastener nominal strength [resistance]* and selection depend on support thickness, *tensile strength* and hardness. If *support connection strength* is not controlled by the *bearing* strength of the *panel* against the fastener, the support material properties must be considered in the small-scale tests.

A rational approach has been to use a single value of P_{nf} to calculate the *diaphragm nominal shear strength [resistance]*, S_{nr} , if one type of support fastener is used in the *diaphragm*. This disregards the thickness-related differences in *connection nominal strength [resistance]* that might occur at end-laps over *exterior supports* shown in Figure D1-1 and at single-*thickness* conditions over *interior supports*. This also disregards the difference that might occur at *side-laps* relative to interior flutes. The *Standard* concludes that the single-*thickness* value based on small-scale tests will control, provided all required edge dimensions and *Standard* equation application limits are met. A detailed discussion of the

differences between end-laps and butt-joints is provided in the examples in the AISI Design Guide (2014). The smallest single-steel sheet *thickness* value at interior flutes should be used in design. This approach can be confirmed for fasteners listed in *Standard* Sections D1.1.1 through D1.1.2. Where small-scale tests indicate otherwise, the smaller end-lap or *side-lap connection* value should be used. AISI S905 (AISI, 2013) can be used to test single-*thickness* shear connections. The *Commentary* of AISI S905 discusses shear tests for multi-layer sheets. When large-scale tests are used to evaluate fasteners, at least one of the large-scale tests should include end-lap conditions to verify that such connections can be made for a particular *panel* and will not control *diaphragm nominal shear strength [resistance]*.

D1.1.6 Support Connection Strength Controlled by Edge Dimension and Rupture

The analytical method determines the number of fasteners per flute required for *diaphragm* strength, and multiple connections are allowed per flute. However, minimum fastener spacing and edge dimensions must be maintained. In addition, individual fastener tear-out or the group effect might become a *limit state* at the fastener cluster – a cluster of fasteners starts to act as one large fastener with failure around the cluster. Group *rupture* is a concern when the spacing within the cluster is tight and the edge dimensions are minimal. The *rupture* cluster edge requirement is analogous to checking e_{\min} for one fastener. This is evaluated using the *rupture* provisions in AISI S100 Sections J6.1 and J6.3. Consult the *Commentary* of AISI S100 for technical background information.

The principle in determining *connection* strength of a fastener group is to determine the least sum value of fastener P_{nf} controlled by failure planes, e.g. the sum of shear planes at each row of fasteners parallel with the force, or staggered planes, if applicable, or failure around the entire fastener group.

D1.2 Side-Lap Connection Shear Strength [Resistance] in Fluted Deck or Panel, P_{ns}

Standard Sections D1.2.1 through D1.2.6 include provisions to determine the *side-lap connection nominal strength [resistance]*, P_{ns} , for fasteners whose *nominal strength [resistance]* is listed in AISI S100 or defined by the referenced research reports.

The *Standard* permits the *connection nominal strength [resistance]* to be determined by tests in accordance with *Standard* Section D1.2.7 and the *diaphragm nominal shear strength [resistance]* to be determined using the analytical approach provided in *Standard* Section D1.

D1.2.1 Arc Spot Welds

Standard Section D1.2.1 is consistent with AISI S100 Section J2.2.2.2. See Section J2.2.2.2 in the *Commentary* of AISI S100 for the corresponding technical background information. The lesser product, tF_w should be used in AISI S100 Eq. J2.2.2.2-1 in the unlikely event that *thickness* or *tensile strength* of the connected sheets varies at the *side-lap connection*.

Weld washers are not used at sheet-to-sheet *side-lap connections* between supports. Industry also recommends that *side-lap* welds be avoided at a *thickness* less than 0.028 in. (0.71 mm).

The spacing limit, $2.75d$, often is irrelevant since normal spacing will exceed this number to avoid multiple “burn-throughs” at *side-laps*.

D1.2.2 Fillet Welds Subject to Longitudinal Shear

Standard Section D1.2.2 is consistent with AISI S100 Section J2.5. See Section J2.5 in the *Commentary* of AISI S100 for the corresponding technical background information. The lesser product, tF_w , should be considered in the unlikely event that *thickness* or *tensile strength* of the connected sheets varies at the *side-lap connection*.

D1.2.3 Flare Groove Welds Subject to Longitudinal Shear

Standard Section D1.2.3 is consistent with AISI S100 Section J2.6. See Section J2.6 in the *Commentary* of AISI S100 for the corresponding technical background information. The more conservative single-valued AISI S100 equation (covering the range $t \leq t_w \leq 2t$) is chosen in the *Standard*.

D1.2.4 Top Arc Seam Side-Lap Welds Subject to Longitudinal Shear

The *top arc seam side-lap weld* has long tenure in *diaphragms* as an *interlocking top side-lap connection*. As with all *side-lap* welds, field quality control by the erector is required. Greater *panel* depth and narrow flute gaps increase the difficulty of making this *connection*. As shown in *Standard* Figure D1.2.4-1, both vertical-to-vertical and hem-to-vertical *connections* are possible. Firm contact is required for fusion and shear transfer. The hem lap is pinched or button-punched to clamp the vertical leg and to establish contact between the three vertical legs. The hem lap must be burned through and fusion established at the top of at least the two adjacent vertical legs, with one being in each of the respective *panels*. At a hem lap, that leg must be closest to the center of the *panel* – see *Standard* Figure D1.2.4-1(a). With proper clamping, fusion at all three legs is common and preferred. Fusion must exist at both vertical legs in Figure D1.2.4-1(b). Blowholes at *top arc seam side-lap weld* ends are to be expected and are not detrimental to the *nominal strength [resistance]*, which is based on the fused length.

The design provisions are based on the Nunna (2012), S.B. Barnes Associates report. The calibration *factors* for the *resistance* equations in *Standard* Section D1.2.4 are compatible with the system *factors* of *Standard* Chapter B. The non-dimensional *resistance* includes the impact of ductility in the ratio, $\frac{F_u}{F_y}$, and the ability to longitudinally distribute *resistance*

along the weld in the ratio, $\frac{t}{L_w}$. Further information is available in the *Commentary* of AISI S100 Section J2.4.1.

The acceptable weld length in design is critical because as lengths get too large, tearing in the vertical leg could become a dominant limit. Both the observed failure modes of tearing in the vertical leg perpendicular to the axis of the weld in thinner steel sheets and shearing of the steel parallel to the axis of the weld for thicker sheets is accounted for in the *Standard's resistance* equation over the prescribed limits of L_w , t , and h_{st} . There is no lower limit on h_{st} for *nominal strength [resistance]* of weld. However, h_{st} must be sufficient to qualify as an edge stiffener when required and must be of sufficient length to allow proper button punching or crimping when those options are chosen.

A minimum spacing is included to avoid excessive shear in the sheets below the weld

line while developing the weld capacity. The *shear rupture* provisions of AISI S100 are adopted to rationally control this concern.

D1.2.5 Side-Lap Screw Connections

At the *side-lap connection*, tilting and bearing limit the screw *connection nominal strength* [resistance]. The provisions conform to AISI S100 Section J4.3.1. The technical background information can be found in Section J4.3 of the *Commentary* to AISI S100. To ensure the required level of performance in structural applications, designers might specify that screws conform to ASTM C1513 or an equivalent standard.

The typical application of this *Standard* section is that $t_1 = t_2$ and $F_{u1} = F_{u2}$. The tilting limit might control and must be checked. The system effect (multiple fasteners in a line) can mitigate but will not fully eliminate the tilting concern.

D1.2.6 Non-Piercing Button Punch Side-Lap Connections

The performance of traditional (manual or mechanically actuated) non-piercing button punch *interlocking top side-lap connections* is dependent on *panel side-lap* dimensions delivered to the field, tool maintenance, and the care of the erector. Analytical equations defining *connection nominal strength* [resistance] also vary as discussed in Bagwell (2008). For these reasons, a lower bound value that is independent of *thickness* is included in *Standard* Section D1.2.6 for shallower *panels*. The contribution of button-punched *side-lap connections* is neglected at deeper *panels*. See *Commentary* Section D1.5.2 that justifies neglecting the *nominal shear strength* [resistance], P_{ns} , for button-punched *cellular deck* when determining the *diaphragm nominal shear strength* [resistance] per unit length, S_n , in accordance with the analytical method of *Standard* Section D1. The same justification applies to deep *panels*. However, the contribution of a button punch is not neglected in the determination of *stiffness*, G' . See *Commentary* Section D5.2.5.

It is acceptable but not mandatory to neglect the contribution of button-punched *side-lap connections* in design where that contribution otherwise would be permitted.

D1.2.7 Other Side-Lap Connections

If a *diaphragm* meets the requirements specified in *Standard* Chapter D, the analytical approach outlined in *Standard* Section D1 should be applicable to other *connections*. However, the *connection strength* and its relationship to *thickness* and mechanical properties of the *connection* materials must be established by small-scale tests as required in *Standard* Section E1.1 for *side-lap connections* not defined in *Standard* Sections D1.2.1 through D1.2.6. The reliability of the *connection strength* established through tests must be consistent with the system *factors* determined in accordance with *Standard* Table B-1. The contribution of other parameters has been established by the tests leading to the analytical method of *Standard* Section D1 and the method has been shown to work over a range of *side-lap connections*.

Several manufacturers have developed proprietary crimping tools that sometimes pierce the vertical legs at the *interlocking top side-lap connections*. These *connection strengths* are determined by tests and differ from the non-piercing button punch *side-lap connections* discussed in *Standard* Section D1.2.6. *Connection flexibilities* for such proprietary *connections* are discussed in *Commentary* Section D5.2.6.

D1.3 Diaphragm Shear Strength per Unit Length Controlled by Support Connection Strength Through Insulation, S_{nf}

The space caused by insulation between *panels* and supports creates cantilever action in the fastener and can significantly reduce the *support connection nominal strength [resistance]*. The contribution of fasteners at interior flutes is neglected in the analytical method. The contribution of *support connection strength* at *interior panel side-laps* is included due to the opposing action of shear at these *support connections* in *diaphragms*. *This action stabilizes the connections* and makes their contribution effective. The opposing shear action typically is not present at edge reactions even if the *support connection* is through a *side-lap*. Therefore, it can be difficult to develop P_{nf} or P_{nfs} at edge lines.

Design provisions given in *Standard* Section D1 are applicable to profiled *panels* with insulation, provided the additional requirements listed in *Standard* Section D1.3 are met.

All *support connections* stabilize the *diaphragm* from *panel buckling*. The Luttrell (1999a) research for MCA indicated that a positive path must be provided at *shear walls* and perimeters to get the shear into and out of a *diaphragm* system. Subsequent work by Lease and Easterling (2006) indicated that shear could be transferred in and out of the *diaphragm* through the end and edge fasteners with insulation present provided the gap between the support and *panel* bottom flat is less than or equal to 3/8 in. (10 mm).

D1.3.1 Lap-Up Condition at Side-Lap

D1.3.1.1 Lap-Up Condition With Side-Lap Fasteners Not Into Support

If *side-lap connections* over supports are not fastened into the support in a lap-up condition, the *diaphragm nominal shear strength [resistance]* is based on the *side-lap connection nominal strength [resistance]*, P_{ns} . The strength contribution of *support connections* in interior corrugations is neglected, but these *connections* stabilize the *diaphragm* from *out-of-plane buckling* and resist uplift. The *diaphragm* shear flow is from sheet-to-sheet until a perimeter detail is reached.

D1.3.1.2 Lap-Up Condition With Side-Lap Fasteners Into Support

If the *side-lap connections* are fastened into the support, the *diaphragm nominal shear strength [resistance]* can be determined using *Standard* Section D1. *Standard* Eq. D1-5 is modified for the insulation effect to determine the factor, β , in accordance with *Standard* Eq. D1.3.1.2-1 by using $\alpha_e = A$, $\alpha_p = A_p$, $\alpha_e^2 = 0.5A$, and $\alpha_p^2 = 0.5A_p$.

In wood supports with *support connection nominal strength [resistance]* determined using *Standard* Section D1.1.4.3, P_{nf} does not always equal P_{ns} , so α_s is determined using Eq. D1-6 while $\alpha_s = 1$ for fasteners into steel supports. The *nominal shear strength [resistance]* of the *support connection* into wood is based on the Luttrell (1999a) report where *connection strength* increases relative to *side-lap connection nominal strength [resistance]* because of fixity in the thicker wood. In the case of steel, this increase is not allowed and the *support connection* strength defaults to the *side-lap connection* strength. The latter requirement can be conservative at thicker steel supports where the same degree of base fixity should occur.

D1.3.2 Lap-Down Condition at Side-Lap

The *diaphragm nominal shear strength [resistance]* can be determined with the factor, β , defined by *Standard* Eq. D1.3.1.2-1 since the interior flute *support connections* are neglected over insulation. The *nominal strength [resistance]* of the *support connection*, P_{nf} , through the bottom flat at *side-laps* equals the value determined in accordance with *Standard* Section D1.1 where insulation is not present. α_s must be calculated because the values of P_{nf} and P_{ns} can differ along the *side-lap*.

Many fasteners listed in *Standard* Section D1.1 are not practical over insulation or where weathertightness is critical. The typical applications are limited to either screws or nails with sealing washers.

D1.3.3 Other Support Fasteners Through Insulation

If the fluted *panels* meet the requirements specified in *Standard* Section D1.3, tests in accordance with *Standard* Section D1.1.5 should be used to determine the *connection nominal strengths [resistances]* for fasteners not listed in *Standard* Sections D1.1.1 through D1.1.4.

D1.4 Fluted Acoustic Panel With Perforated Elements

Perforations may be located in the bottom flats or other elements of the *acoustic panels*. A common design has perforations only in the fluted *panel webs*. These *web* perforations will not affect the *support* or *side-lap connection nominal strength [resistance]* since no perforations exist at the *diaphragm* supports and at *panel side-laps* where *connections* are made. However, the perforations might reduce the *stiffness* of the *diaphragm* system, and the reduction can be calculated using *Standard* Section D5.1.2 and Appendix 1 that is based on Luttrell (SDI, 2011). Contact the *panel* manufacturer for the design parameters reduced for perforations.

Designs that require *connections* through perforated zones must be tested using *Standard* Section D1.1.5 and D1.2.7 as applicable.

D1.5 Cellular Deck

D1.5.1 Safety Factors and Resistance Factors for Cellular Deck

Bagwell (2008) reported that 35 tests of *cellular deck* using various combinations of *cellular deck thickness* and fastener types were performed. The mean ratio, P_{test}/P_{theory} , was 0.98 based on the theory of *Standard* Section D1. This set of data fits well within the scatter of the total test data (SDI, 1981) that is the basis of *Standard* Table B1.1. Consequently, the *safety* and *resistance factors* given in *Standard* Table B1.1 are also applied to *cellular deck*.

D1.5.2 Connection Strength and Design

The Bagwell (2008) test data indicated that it was difficult to make button-punched *side-lap connections* (*Standard* Section D1.2.6) on some products. The *cellular deck* ratio, $S_{n\ test} / S_{n\ theory}$, has less scatter when the button punch contribution is neglected. Because of that, the *diaphragm nominal shear strength [resistance]* contribution from button-punched *side-lap connections* is ignored in the *Standard*. This does not apply to proprietary button punches or other proprietary crimping tool *connections* with *nominal strength [resistance]* established by test.

Typically, *cellular deck* profiles cannot be end-lapped. However, the total steel *thickness* of *cellular deck* that fasteners must penetrate can be large at supports. Depending on *cellular deck* product design, *support connections (fasteners)* might not engage top and bottom elements of the *cellular deck* at interior flutes. For example, individual top hats of the *cellular deck* are fastened to a bottom plate, and the bottom flats of the hat are not large. This might create a significant gap; thus, only the bottom plate is continuous over the support. In such cases, only the bottom plate *thickness* is used to determine P_{nf} .

Examples of *Standard* design provisions D1.5.2 (b) and (c) are illustrated in Figure C-D1.5.2-1. Shear in the *diaphragm* flows from sheet to sheet through panel *side-lap connections*. Where a *side-lap* does not provide a sound path without going through the support, fasteners are required at either side of the *side-lap* over supports. In Figure C-D1.5.2-1(a), two fasteners are required and the plane of shear transfer is below the bottom plate of the *cellular deck*. *Support connection nominal strength [resistance]*, P_{nf} , and the effective diameter, d_e , for a weld are determined using one bottom plate *thickness* plus one top *deck thickness*. In Figure C-D1.5.2-1(b), the path is from sheet to sheet and requires one fastener if edge conditions are satisfactory. The shear transfer plane is then below the bottom plate of the top *cellular deck* to the right of the figure, and P_{nf} is determined using that bottom plate *thickness*. The effective diameter, d_e , for a weld is then determined using two bottom plate *thicknesses* plus one top *deck thickness*.

The weld *configurations* shown in Figures C-D1.5.2-1(a) and C-D1.5.2-1(b) are acceptable as long as required edge dimensions and combined *thickness* limitations are met. They are not necessarily equivalent, and their respective capacities can be calculated using *Standard* Section D1.1.1 as specified in Section D1.5.2 (b).

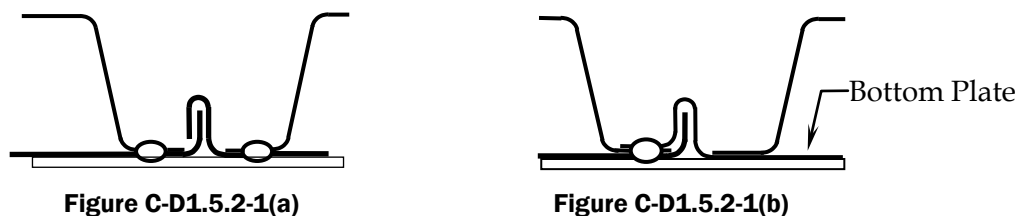

Figure C-D1.5.2-1 Cellular Deck Interlocking Side-Laps

D1.6 Standing Seam Panels

Since *standing seam roof system* clips at *side-lap connections* typically permit the *standing seam roof system panels* to expand and contract (float) along the *panel* longitudinal direction, it is difficult to develop longitudinal shear. Additional *support connections* may not be present. In such a case, P_{nf} does not exist and P_{ns} may be small. The calculated *diaphragm nominal shear strength [resistance]* per unit length, S_n , determined using *Standard* Section D1 is negligible. The *Standard* codifies the historical approach where S_n is set equal to zero. The system can be tested in accordance with *Standard* Chapter E to establish *diaphragm nominal shear strength [resistance]*. Some manufacturers have tested their products to define this contribution.

Standard Section D1.6 enumerates some of the same testing principles that are contained in ASTM E1592. *Standing seam roof system panels* also can provide some lateral stability to supports. This *resistance* is similar to but not the same as *diaphragm shear*. Consult the *panel* manufacturer for guidance in both areas.

AISI CF97-1 suggests tests for a *diaphragm* system that is fixed at one end using the method of AISI S907 and two test *configurations*: (1) with no end restraint, and (2) with end restraint at both ends. AISI CF97-1 then provides a method to extend the large-scale tests to a larger building application. This is consistent with the intent of the AISI S310 *Standard* where lack of fixity must be addressed.

D1.7 Double-Skinned Panels

Double-skinned panels are illustrated in *Standard* Figure D1.7-1. If the top *panels* are not connected to supports but connected to sub-*purlins* or sub-*girts* at an elevated plane, the shear force in the top *panels* will not be efficiently transferred to the supports. This is because of roll at the sub-*purlins* or sub-*girts* and the flexural flexibility of the bottom *panel webs* (vertical elements). Therefore, the contribution of the top *panels* is ignored and only the bottom *panels* provide the *diaphragm shear strength [resistance]*, which is determined in accordance with *Standard* Section D1.

$(\lambda-1)$ in *Standard* Eq. D1-1 represents a reduction in the *nominal strength [resistance]*, P_{nf} , at the corner *support connections* in each *panel* due to local distortion in the *panel* profile at a *side-lap*. Since only the bottom *panel's* contribution is considered, the design assumption of the double-skin system is conservative. Also, since the bottom *panel side web* is relatively stiff and prevents distortion at the corner fasteners, the *Standard* eliminates the reduction by setting $\lambda = 1$.

The bottom *panel's* flat is often very wide, and local waves caused by *shear buckling* across this flat are a major concern. Appearance at *service load* is often critical in these panels. To avoid *shear buckling*, an additional rational *limit state* is imposed in the *Standard*. If the bottom *panel* is fastened to the support, as illustrated in *Standard* Figure D1.7-1, the bottom *panel* vertical elements can be considered as beam flanges (where the depth, h , of the beam is defined as the spacing between the vertical elements). The *diaphragm* supports can be considered as transverse stiffeners (where the distance, a , between transverse stiffeners of reinforced beam *webs* is defined as the spacing of *diaphragm* supports). The *nominal shear stress* of the beam *web* (the bottom *panel's* horizontal flat in the figure) is then determined in accordance with AISI S100 Section G1 based on the herein defined h/t and a/h , where t is the *thickness* of the bottom *panel*. The beam *web* area is taken as the area between the vertical elements of the bottom *panel* (ht), and the unit area is taken as the *web* area divided by the spacing between the vertical elements of the bottom *panel*. The *diaphragm nominal shear strength [resistance]* controlled by *shear buckling* is calculated using *Standard* Eq. D1.7-2. Since S_n is the *nominal strength [resistance]* per unit length, the controlling *diaphragm* strength for design is based on the lowest *available strength [factored resistance]* considering all *limit states*.

D2 Stability Limit, S_{nb}

D2.1 Fluted Panel

Standard Section D2.1 determines the *diaphragm nominal shear strength [resistance]* that is controlled by *shear buckling (out-of-plane panel buckling)*. This *shear buckling* might manifest as several relatively large diagonal waves across several *panels* or as general (column-like) *buckling* between supports. When several diagonal waves occur, *post-buckling strength* can be present until *connection failure* occurs, which further controls the *diaphragm resistance*. The *load*

on these *connections* is redistributed by tension field action and may not follow the model of *Standard* Section D1. *Buckling* initially is a material limit, so the *Standard* Table B1.1 *factors* in *Standard* Section B1 vary from the *connection*-related limits.

Standard Eq. D2.1-1 is a theoretical limit that includes the orthotropic nature of the *diaphragm* fluted *panel* and represents the same theory used to design corrugated *webs* in girders. This theory was presented in SDI DDM03 (2004) and was initially evaluated by Easley (1975). The Easley research contained *confirmatory tests* limited to single spans. For practical cases, Easley and McFarland showed that the elastic *buckling load* for thin corrugated metal *diaphragms* is predicted using Eq. C-D2.1-1. Since the strong axis *flexural stiffness* is more commonly based on I_x (I_{xg} in the *Standard*), the axes presented in Eq. C-D2.1-1 are shifted for convenience relative to that presented in the Easley paper.

$$S_{nb} = \frac{36\beta_E D_y^{1/4} D_x^{3/4}}{L_v^2} \quad (\text{C-D2.1-1})$$

where

β_E = *Buckling* coefficient allowance for end restraint and determined by tests
= 1.07

D_x = Strong axis *flexural stiffness* per unit width, k-in. (kN-mm)

$$= \frac{EI'_x}{d} = EI_x \quad (\text{C-D2.1-2})$$

where

E = Modulus of elasticity of steel, 29500 ksi (203000 MPa)

I'_x = Moment of inertia of one corrugation, in.⁴/*pitch* (mm⁴/*pitch*)

I_x = Moment of inertia per unit width, in.⁴/in. (mm⁴/mm)

d = *Panel* corrugation *pitch*, in./*pitch* (mm/*pitch*). See *Standard* Figure D2.1-1

$$I_x = \frac{I'_x}{d}$$

D_y = Weak axis *flexural stiffness* per unit length, k-in. (kN-mm)

$$= \left(\frac{Et^3}{12} \right) \frac{d}{s} \quad (\text{C-D2.1-3})$$

where

s = Developed flute width per *pitch* determined in accordance with *Standard* Eq. D2.1-2, in./*pitch* (mm/*pitch*)

t = Base steel *thickness* of *panel*, in. (mm)

L_v = Span of *panel* between supports with fasteners, ft (m)

$$S_{nb} = \frac{36\beta_E E}{L_v^2} \sqrt[4]{\frac{t^3 I_x^3}{12} \left(\frac{d}{s} \right)} \quad (\text{C-D2.1-4})$$

Eq. C-D2.1-4 is dimensionally admissible for any unit system, but dimensional analysis is required to adjust for product and material data as commonly presented. Examples are:

U.S. Customary Units

Where I_{xg} has units, in.⁴/ft, while other parameters and units are as shown in the definitions (I_{xg} is substituted for I_x to agree with the *Standard*):

$$S_{nb} = \frac{36(1.07)(29500)}{L_v^2} \left(\frac{\text{k}}{\text{in.}^2 \text{ft}^2} \right) \sqrt[4]{\frac{t^3 I_{xg}^3}{12} \left(\frac{\text{d}}{\text{s}} \right) \left(\frac{\text{in.}^3 \text{in.}^{12} \text{in.}}{\text{ft}^3 \text{in.}} \right) \left(\frac{1 \text{ft}^3}{1728 \text{in.}^3} \right)}$$

$$S_{nb} = \frac{36(1.07)(29500)}{12L_v^2} \left(\frac{\text{k in.}^3}{\text{in.}^2 \text{ft}^2} \right) \left(\frac{1 \text{ft}}{12 \text{in.}} \right) \sqrt[4]{t^3 I_{xg}^3 \left(\frac{\text{d}}{\text{s}} \right)}$$

$$S_{nb} = \frac{7890}{L_v^2} \sqrt[4]{t^3 I_{xg}^3 \left(\frac{\text{d}}{\text{s}} \right)} \frac{\text{k}}{\text{ft}}$$

SI Units

Where I_{xg} is substituted for I_x , while other parameters and units are as shown in the Definitions:

$$S_{nb} = \frac{36(1.07)(203000)1000}{L_v^2} \left(\frac{\text{kN}}{\text{m}^2 \text{m}^2} \right) \sqrt[4]{\frac{t^3 I_{xg}^3}{12} \left(\frac{\text{d}}{\text{s}} \right) \left(\frac{\text{mm}^3 \text{mm}^{12} \text{mm}}{\text{mm}^3 \text{mm}} \right)}$$

$$S_{nb} = \frac{36(1.07)(203000000)}{1.861L_v^2} \left(\frac{\text{kN mm}^3}{\text{m}^2 \text{m}^2} \right) \left(\frac{1 \text{m}^3}{10^9 \text{mm}^3} \right) \sqrt[4]{t^3 I_x^3 \left(\frac{\text{d}}{\text{s}} \right)}$$

$$S_{nb} = \frac{4.20}{L_v^2} \sqrt[4]{t^3 I_{xg}^3 \left(\frac{\text{d}}{\text{s}} \right)} \frac{\text{kN}}{\text{m}}$$

Nunna (2011) compared existing *diaphragm* test data with the equations in existing analytical models. The 28 tests exhibited *panel buckling* and included five multiple-span tests plus one hybrid test mixing multiple- and single-spans. The equation in the *Standard* represents a best fit between theory and tests. The *buckling* coefficient increased relative to the previous SDI DDM03 (2004) value. The same *buckling strength* is attributed to single and multiple-span applications. The Nunna report indicates that the *resistance factors* are reasonable when determined in accordance with *Standard* Table B-1. The evaluation results were rationally extended to the entire acceptable range of *Standard* Section D1.1.

The *gross section* moment of inertia should be used in the stability analysis, and this might be more representative of the available *buckling stiffness* of the *panel* during tests. However, section properties are typically published at a *stress* level consistent with *service loads* and these values are commonly used in *diaphragm* design to determine *diaphragm* strength and develop *load* tables.

The *nominal shear strength [resistance]* of *diaphragms* formed by fluted *panels* is based on the typical fluted *panel* section illustrated in *Standard* Figure D2.1-1. Perforations can affect the moment of inertia and the d/s ratio. Luttrell (SDI, 2011) provided an analytical method to determine this effect. Contact the *deck* or *panel* manufacturer for these parameters.

Testing is always allowed to verify *buckling* capacity.

D2.2 Cellular Deck

There is limited (if any) data on *panel buckling* of *cellular deck*. *Cellular deck* was not considered in the derivation of *Standard* Eq. D2.1-1, but rational design allows that provision to be applied using the moment of inertia of the *cellular deck* and the *thickness*, *pitch*, and developed width of the top *deck*. This is similar to using the top *deck buckling strength* but amplifying that *strength* using the full *cellular deck* moment of inertia. This is *rational*

engineering that neglects some of the shear sharing between the top *deck* and bottom plate and the additional torsional restraint of the closed cell units.

Perforations can affect the moment of inertia of the *cellular deck* and the d/s ratio of the top element. The top element fluted *deck* is rarely perforated in *cellular deck*, but the bottom element is commonly perforated to provide acoustic treatment.

Testing is always allowed to verify *buckling* capacity.

D3 Shear and Uplift Interaction

It is common for *connections* to experience simultaneous shear and tension (uplift) when the *diaphragm* resists a shear force caused by wind *load*.

The *connection nominal shear strength [resistance]*, P_{nft} , associated with a tensile *load* should satisfy the interaction equations outlined in *Standard* Section D3, and P_{nft} should replace P_{nf} in the equations provided in *Standard* Section D1 to determine the *diaphragm nominal shear strength [resistance]* per unit length, S_{nf} . Whenever possible, the *Standard's* interaction equations are based on the AISI S100 provisions, but since P_{nft} is required, the *Standard's* equations have been altered to make them more directly useful.

Where *nominal shear strength [resistance]* of a *diaphragm* is determined in accordance with Section D1 and is based on P_{nft} , the system *factor* determined in accordance with *Standard* Table B-1 is applied to the controlling S_{nf} in accordance with *Standard* Eq. D-1 or Eq. D-2, as applicable. The *available strength [factored resistance]* should be greater than or equal to the *required shear strength [shear per unit length due to factored loads]* in accordance with *Standard* Section C2.

P_{nft} can be determined using ASD, LRFD, or LSD. The result can vary slightly among the design methods.

D3.1 Support Connections

Consistent with AISI S100, three *limit states* in tension must be considered. The *Standard* allows linear interaction in lieu of testing.

D3.1.1 Arc Spot Welds

The provisions given in *Standard* Section D3.1.1 are consistent with AISI S100 Sections J2.2.4. See the corresponding section in the *Commentary* of AISI S100 for technical background information.

D3.1.2 Screws

D3.1.2.1 Screws Into Steel Supports

Standard Section D3.1.2.1 is consistent with AISI S100 Sections J4.5.1, J4.5.2 and J4.5.3. See the corresponding sections in the *Commentary* of AISI S100 for technical background information.

Three tensile limit states are possible in the *connection*: pull-out, pull-over, and fracture in the screw shank. The first is associated with the *thickness* of the *support*, the second is associated with the sheet steel *thickness* of the *panel*, and the third is a screw

property that typically does not control. *Standard* equations are provided to investigate these three *limit states*.

It is rational to use the controlling value of P_{nf} (*bearing*, *tilting*, or *shank fracture*) in *Standard* Sections D3.1.2.1 (a) and (b). Only breaking *nominal strengths* [*resistance*] should be used in *Standard* Section D3.1.2.1 (c).

S_n is directly proportional to P_{nft} in the presence of wind uplift and P_{nf} in the absence of wind uplift. For pull-over, *Standard* Eqs. D3.1.2.1-1 and D3.1.2.1-3 have been adjusted for ease of application. $\frac{P_{nft}}{\Omega_d}$ is substituted for the fastener's *required allowable shear strength*, \bar{V} , in AISI S100 Eq. J4.5.1-1. $\phi_d P_{nft}$ is substituted for the fastener's *required shear strength*, \bar{V} , [shear force due to *factored loads*] in AISI S100 Eq. J4.5.1-1. A similar adjustment is used for pull-out.

Simple design suggests that each *load effect* be considered separately and a screw pattern chosen to resist the *required diaphragm shear strength* [shear force due to *factored loads*]. Additional *support connections* are then added to resist uplift. The final design should be checked for interaction, and adjustments should be made as needed.

An anomaly exists at pull-over *Standard* Eq. D3.1.2.1-2 in *ASD* and Eq. D3.1.2.1-4 in *LRFD* and *LSD*. A reduction of 6 to 19% exists in screw *connection shear capacity* when there is no uplift. This is because the *diaphragm system resistance factor*, ϕ_d , for *wind loads* is more than 23% greater than the *resistance factor*, ϕ , used in the *Standard's* interaction equation. An anomaly also exists at pull-out *Standard* Eq. D3.1.2.1-6 in *ASD* and Eq. D3.1.2.1-8 in *LRFD* and *LSD* since a 10 to 23% reduction in screw shear capacity exists when there is no uplift. This is because the *diaphragm system resistance factor*, ϕ_d , for *wind loads* is more than 33% greater than the *resistance factor*, ϕ , used in the *Standard's* interaction equation. (A similar anomaly exists in *LRFD*, but is negligible.) Rational design in *LSD* might allow no reduction of *factored resistance* in shear when the effect due to *factored tension loads* is less than 5% of the *factored resistance* in tension in the absence of shear.

Engineers often use linear interaction design when other information is not available. The *Standard* permits this approach when design is outside the test limits of the existing pull-over, pull-out, or breaking *nominal strength* [*resistance*] equations.

D3.1.2.2 Screws Through Bottom Flats Into Wood Supports

Three *limit states* may exist: one failure controlled by wood properties, and two failures controlled by steel properties. Therefore, in addition to this section, both *Standard* Sections D3.1.2.1 and D3.1.2.2 must be investigated.

Where *bearing* of the steel *panel* against the screw controls *connection nominal shear strength* [*resistance*], P_{nfv} , and *nominal tension strength* [*resistance*] is controlled by pull-over, the interaction equation of *Standard* Section D3.1.2.1(a) applies. Fracture in the screw is unlikely for most applications but should still be checked per *Standard* Section D3.1.2.1(c). Otherwise, where *bearing* of the screw against wood, P_{nfw} , or pull-out from wood, P_{nT} , controls, the interaction equations of *Standard* Section D3.1.2.2 apply.

The *Standard's* shear and tension interaction provisions (controlled by wood bearing and pull-out) for screws fastened into wood supports are obtained from AWC NDS

(2012), and the equation is an application of the Hankinson formula. T or \bar{T} is determined considering that *support connections* resist the total uplift. However, V and \bar{V} depend on the load sharing of both *side-lap connections* and *support connections*, and that load sharing is indicated in Eqs. D1-1 and D1-2. The design requires iteration as a *diaphragm configuration* is evaluated. To perform the iteration, an engineer can assume a P_{nft} less than P'_{nfw} , where P_{nft} is the *nominal strength [resistance]*. When the *diaphragm required strength [force due to factored loads]* per unit length equals the *available strength [factored resistance]*, then $V = \frac{P_{nft}}{\Omega}$ for ASD or $\bar{V} = \phi P_{nft}$ for LRFD and LSD. Calculate P_{nft} using Eq. D3.1.2.2-1 and the values of V or \bar{V} based on the assumption and the values of T or \bar{T} based on the design analysis, and compare the calculated P_{nft} with the assumed P_{nft} . Depending on the difference, a new value of P_{nft} is assumed for the *diaphragm configuration*. S_{nf} is then calculated using Section D1 and the final P_{nft} . If Eq. D3.1.2.2-4 is satisfied, design is considered satisfactory for that *configuration*. Depending on the spread, alternate *diaphragm configurations* can be considered and the process repeated.

Since sufficient data does not exist to provide an interaction equation for fasteners through the top flats, rational design or testing is required.

D3.1.3 Power-Actuated Fasteners

The *power-actuated fasteners (PAFs)* used in design should be specified and no substitutions should be allowed unless equivalence is substantiated by test data.

For *PAFs*, small-scale tests should be performed to determine the combined shear and tension effect in accordance with AISI S905. If a test-based interaction equation is not available, or development is not justified, the *Standard* allows a linear interaction equation. The *safety* and *resistance factors* for *available pull-over strength [factored resistance]* and the strength itself should then be determined in accordance with AISI S100 Section J4 for screws. When washers are present on *power-actuated fasteners*, it is rational to use the pull-over equation for screws in AISI S100 Section J4.4.2 to define P_{nov} . Pull-out must be investigated as a *limit state* and these *nominal strengths [resistances]* can be obtained from the fastener manufacturer.

Luttrell (Section 4.10 of SDI 2004) has done the required small-scale tests to establish P_{nf} and the interaction for particular (but not all) *PAFs*. When an interaction equation listed in SDI DDM03 (2004) is used to satisfy the *Standard's* testing requirement, the *resistance factor* for shear, ϕ_d , is the value listed in *Standard* Table B1.1 for screws, and the *resistance factor* for a *power-actuated fastener* subjected to tension, ϕ_t , equals 0.5. The SDI listed equations assume pull-over will control tension.

Proprietary *power-actuated fastener* interaction equations may be available from manufacturers and could be similar to those listed in SDI DDM03 (2004), but the *Standard* requires test verification, and the *resistance factors* must be determined in accordance with *Standard* Section E1.2.2. The statistical parameters, M_{mv} , V_M , F_{mv} , and V_F , are listed in AISI S100 Table K2.1. To ensure that the calibrated interaction equation has the equivalent accuracy as provided by the *Standard's* *diaphragm* system in Section D1, the calibrated interaction equation should have an equal or smaller *safety factor*, and an equal or greater *resistance factor* than the requirements of *Standard* Table B-1. Accuracy is dependent on the

average ratio (test/theory) of the *PAF* interaction equation and the scatter which define the factors. Equivalent calibration factors could require a theoretical strength reduction.

If the *support connection nominal shear strength [resistance]*, P_{nf} , can be determined in accordance with *Standard* Section D1.1.5 and the interaction effect is established by small-scale tests, large-scale shear *diaphragm* tests are not required. It should be noted that it is extremely difficult to conduct large-scale shear and uplift interaction tests using test facilities such as air bags or vacuum chambers. The large-scale tests can be used to determine the *diaphragm nominal shear strength [resistance]* per unit length, S_n , and the *support connection nominal shear strength [resistance]*, P_{nf} , and to define the *resistance factors* without the uplift effect. The interaction equations will then be used to define P_{nft} .

D3.1.4 Nails Through Bottom Flats Into Wood Supports

The design provisions considering the interaction of shear and tension of nails into the wood supports are obtained from AWC NDS (2005). Three *limit states* are considered: one failure controlled by wood properties, the second failure controlled by steel *panel* properties (combination of nail bearing against the panel in shear and nail pull-over), and the third controlled by nail fracture properties. The pull-over *nominal strength [resistance]* equation and interaction equation for nails are the same as those for screws, which is given in Section D3.1.2.1. Washers may be required for weathertightness. Fracture in the nail is unlikely to occur for most applications but is checked in *Standard* Section D3.1.2.1(c).

An interaction equation for fasteners through the top flats is not included. Rational design or testing is required.

D3.2 Side-Lap Connections

The *nominal shear strength [resistance]* reduction due to wind uplift does not need to be considered for *side-lap connections*. The *side-lap connections* will move along with the steel *panels* under the wind uplift and there is negligible differential movement at the *side-lap* to cause strain in the *side-lap connections*. As a result, no tension force is introduced.

D4 Steel Deck Diaphragms With Structural Concrete or Insulating Concrete Fills

Welded wire fabric (WWF) may be necessary for flexure or fiber-reinforced concrete for *serviceability* in *structural concrete*, but the *strength [resistance]* contribution of WWF or fibers is not considered in *diaphragm shear strength* analysis in accordance with test findings reported by SDI. Several of the *structural concrete* slab *diaphragm* tests reported by Easterling and Porter (1988) did not include WWF or fibers.

Slabs with cover, d_c , greater than 6 in. (152 mm) are permitted but the analytical value, S_n , should be based on a maximum value of 6 in. (152 mm).

Lightweight *insulating concrete* is discussed in *Standard* Section D4.3.

D4.1 Safety Factors and Resistance Factors

The *factors* for the calculation of *available diaphragm shear strength [factored resistance]* are limited to *Standard* Section D4.1. However, if the *diaphragm nominal strength [resistance]* is determined through large-scale testing, the *safety* and *resistance factors* should be determined in accordance with *Standard* Section E1.2.2 for *structural concrete* and *lightweight insulating*

concrete fill. For *structural concrete*, Standard Section E1.2.2 is not limited by the values provided in Standard Section D4.1.

D4.2 Structural Concrete-Filled Diaphragms

The *nominal shear strength [resistance]* for *diaphragms* with *structural concrete* fill is the summation of the *deck* shear strength and the shear strength of the concrete over the *deck*. The equations provided in Standard Section D4.2 are adopted from SDI DDM03 (2004). The *deck* contribution is consistent with Eq. D1-1. However, the concrete bond stabilizes the *deck* at the *side-lap* corner so λ is 1 and there is no $(\lambda - 1)$ reduction. The concrete contribution typically dominates. A rational limit of 25% of the total *nominal shear strength [resistance]* is imposed on the *deck* contribution since concrete failure can be semi-brittle and will limit the contribution of the *deck* in the *diaphragm* field. This also avoids overstating the additive contribution of thicker *deck* with many *support* and *side-lap connections*. However, the total *diaphragm nominal shear strength [resistance]* cannot be less than the *deck* alone.

D4.3 Lightweight Insulating Concrete-Filled Diaphragms

The equations provided in Standard Section D4.3 are adopted from SDI DDM03 (2004). The system in Standard D4.3(a) is based on lightweight *insulating concrete* fill with vermiculite aggregate or cellular foaming agent. The system in Standard D4.3(b) is based on a layer of lightweight *insulating concrete* fill placed to a level slightly above the corrugation top flats or crests. Rigid insulation boards of expanded cellular polystyrene, having about 2% of the board surface area containing holes, are then embedded into the concrete and the concrete slurry fills the hole openings. A 2-in. (50-mm) thick topping of *insulating concrete* is placed over the polystyrene to finish the *diaphragm*: e.g., if the polystyrene insert is 1 in. (25.4 mm) thick, the total cover over the *form deck* is approximately 3- $\frac{1}{4}$ in. (82.6 mm) – i.e. 1/4 in. (6.35 mm) bonding slurry plus 1 in. (25.4 mm) insert plus 2 in. (50.8 mm) topping. Insulation boards are held 3 ft (1 m) back from the *diaphragm* shear-resisting reaction lines (*shear walls* or interior *moment frames*), so the *insulating concrete* fill is full depth (3- $\frac{1}{4}$ in. (82.6 mm) in the example) in those zones. Full depth provides a path to transmit shear out of the fill and develop concrete bond at this critical reaction transfer zone. If a system differs significantly from these descriptions, *diaphragm nominal shear strength [resistance]* should be determined in accordance with Standard Chapter E. The insulation fill manufacturer may be able to provide this test information.

Type (b) is rarely used, and Standard Eq. D4.3-2 predicts a lower bound *diaphragm nominal shear strength [resistance]* for 2-in. (50.8-mm) cover over insulating board based on test data for various covers over *deck* and board thickness. In type (b), the minimum probable solid *insulating concrete* thickness over *deck*, d_c , near *lateral force-resisting system* lines is about 3 in. (76.2 mm) for 2-in. (50.8-mm) fill thickness over board. Using Standard Eq. D4.3-1, $d_c = 3$ in. (76.2 mm), and $f'_c = 125$ psi (0.862 MPa) lead to an *insulating concrete* contribution of 0.537 klf (7.84 kN/m). Eq. D4.3-2 leads to 0.716 klf (10.4 kN/m), so the results are not entirely out of line. When cover over board is 3 in. (76.2 mm), the *insulating concrete* fill thickness over *deck* at a *lateral force-resisting system* line is about 4 in. (102 mm) minimum and type (a) provides 0.716 klf (10.4 kN/m). Types (a) and (b) converge and for greater fill cover over board, the type (b) *diaphragm nominal shear strength [resistance]* equation predicts a lower value.

Differing amounts of Portland cement, water, aggregates (vermiculite and/or perlite)

and/ or preformed cellular foam are mixed together dependent on specific requirements (National Roof Deck Contractors Association, 2012). The insulating characteristics could be enhanced either by the entrapped air in the pores of the expanded aggregate, or by air injected under pressure into the concrete mix using the foaming agent to stabilize the mix. The latter creates closed cell air bubbles within the (cellular *insulating concrete*) mix. Cellular *insulating concrete* may contain no sand or other aggregate. Consult the *insulating concrete* fill manufacturer for specific product requirements and installation instructions. The cellular *insulating concrete* foaming agent should conform to ASTM C869.

Lightweight *insulating concrete* fill is typically placed over *form deck* other than *composite deck*. Depending on the roof membrane and fill manufacturer's requirements, the *deck* may require venting.

D4.4 Perimeter Fasteners for Concrete-Filled Diaphragms

For *structural* and lightweight *insulating concrete*-filled *diaphragms*, sufficient *connections* must be provided along the perimeters so shear forces can be transferred into and out of the *diaphragm* at perimeter transverse supports, such as spandrel beams, and at *edge panel* longitudinal supports, such as *shear walls*, braced frames, or *moment frames*. The designer should include supports in the *diaphragm's* bottom plane to allow fastener installation and shear transfer. However, this design requirement is sometimes wrongly overlooked at edges parallel with the *deck* span. See the *Commentary* on Section D1 since this concern also applies without fill.

Standard Eqs. D4.4-1 and D4.4-2 are based on the assumption that the *nominal shear strength [resistance]* per unit length, S_{nv} is proportional to the number of edge fasteners, n_e , along a *panel* length, L , but n_e should not be less than L/α , where α is an industry serviceability limit for connection spacing at larger L_v . At perimeters perpendicular to the *deck* span, the number of fasteners per unit width, N , is determined based on the assumption that the *diaphragm* strength is proportional to the number of fasteners at perimeters. Where the *required* S_n varies along the *diaphragm* span, L_d , the required N can also vary along that length. Statics only requires the N *connections* to resist the component perpendicular to the *deck* span, i.e., S_n . The limited *flexural stiffness* of most spandrel beams about the weak axis would not allow development of a component parallel with the *deck's* span even where that component exists. SDI DDM03 (2004) addresses similar details and concerns that occur at slab perimeters or discontinuities at large holes in *diaphragms*.

Diagonal tension in *structural* or *insulating concrete*-filled *diaphragms* is associated with two perpendicular shear components. Since most of the shear is flowing through the fill in *structural concrete*, those components must be resisted by perimeter *connections* at building corners or perimeter points along reaction lines, for that is where shear gets out. For *structural concrete*-filled *diaphragms*, because of potential force redistribution and the large number of fasteners along longitudinal (reaction) and transverse (along L_d) perimeter lines, the *Standard* does not mandate an increase of *connections* at the corners.

It should be noted that N should satisfy the industry maximum allowable spacing requirement in addition to developing the strength resistance requirement.

Standard Eq. D1-2 addresses the shear resistance needed along the perimeters and at the corners for *diaphragms* without concrete fill.

D4.4.1 Steel-Headed Stud Anchors

The *structural concrete* develops a significant portion of the total *diaphragm nominal shear strength [resistance]*, which can be an order of magnitude greater than the *strength* without fill. The *nominal shear strength [resistance]* of other fasteners at *edge panels* may adequately provide the *nominal strength [resistance]*, so steel-headed stud anchors are not required. At larger *loads*, steel-headed stud anchors may be required to transfer shear from the concrete slab to the *lateral force-resisting system* or to the transverse perimeter supports. The welded steel headed-stud anchors provide a direct path to collect shear from the concrete. This avoids having to count on the chemical bond between the *deck* and the concrete to transfer shear, and having to use an excessive number of other types of fasteners. The steel-headed stud anchors also can resist end “slip over” in *structural concrete* slabs on *deck* and provide composite beam *resistance* at the supports.

The required number of welded steel-headed stud anchors at *edge panels*, n_e , depends on the magnitude of the *required diaphragm strength [shear due to factored loads]* along the line of transfer, and n_e should be determined in accordance with *Standard Section D4.4*. Steel-headed stud anchor *nominal strength [resistance]* is determined in accordance with ANSI/AISC 360 (2010). The maximum spacing required by ANSI/AISC 360 should be checked in addition to determining the number of steel-headed stud anchors required by *Standard Eq. D4.4-1* or *D4.4-2*.

The *thickness* of the *deck* supports must be considered before selecting anchors to transfer shear. ANSI/AISC 360 (2010) provides guidance on support *thickness* and the impacts of galvanized thickness and *deck thickness(es)* on steel-headed stud anchor installation. ANSI/AISC 360 also provides guidance on spacing and edge dimensions. Where mechanical shear *connections* are allowed by the building code, they may be used in lieu of welded steel-headed stud anchors, but the designer should avoid mixing shear *connection* types unless the *connection flexibilities* are comparable.

The reliability of the *connection nominal shear strength [resistance]*, P_{nfs} , must be consistent with that of the *diaphragm* system. The *safety factor* provided in ANSI/AISC 360 (2010) for steel-headed stud anchors is 2.31 and the *resistance factor* is 0.65. These *factors* are less severe than *Standard Section D4.1*, so the number of fasteners, n_e , should be determined in accordance with *Standard Eq. D4.4-1* or *D4.4-2* using the ANSI/AISC 360 *nominal strength [resistance]*.

A mechanical shear *connection* may be used in *structural concrete* where the *connection safety factor* is greater than or the *resistance factor* is less than the factors in *Standard Section D4.1*. In such cases, the reliability of the *connection nominal shear strength [resistance]*, P_{nfs} , is not consistent with that of the *diaphragm* system. The mechanical shear *connection's nominal strength [resistance]*, P_{nfs} , should be reduced proportionately to the respective factors when calculating n_e in accordance with *Standard Section D4.4*. P_{nfs} should not be increased if the *connection's* factors obtained from tests are better than the *diaphragm* system factors. As an example, the *safety factor* for the shear *connection* in concrete is 4 (published by manufacturer or determined by push-off tests), but the *diaphragm* system's *safety factor* is 3.25; therefore, a reduced $P_{nfs} = (3.25/4) P_{nfs}$ should be used in *Standard Eqs. D4.4-1* and *D4.4-2*. A similar reduction may be required in *Standard Section D4.2* if the factors also are not consistent when based on tests with *deck* alone and in accordance with AISI S905 (2013).

This *Standard* provision does not preclude the use of a proprietary shear stud or a mechanical shear *connection* in lightweight *insulating concrete* or *structural concrete-filled diaphragms* with strength verified by large-scale test using *Standard* Chapter E.

D5 Diaphragm Stiffness

D5.1 Stiffness of Fluted Panels

D5.1.1 Fluted Panels Without Perforated Elements

Standard Eq. D5.1.1-1 used to calculate the *diaphragm stiffness*, G' , is based on SDI DDM03 (2004) and Luttrell (Luttrell, 1999a and 1999b; and MCA, 2004). It was developed based on the fluted *panel* as shown in *Standard* Figure D2.1-1. The background information for this equation is provided in *Commentary* Appendix 1. In lieu of analytical Eq. D5.1.1-1, large-scale tests may be performed in accordance with *Standard* Chapter E.

Stiffness based on tests (AISI, S907) is determined at $0.4S_{ni \text{ test}}$ and is used to calculate in-plane deflection at the *nominal load* [*specified load*]. In *Standard* Eq. D5.1.1-1, the K factor measures the relationship between *support connection* and *side-lap connection flexibilities*. In the lap-down case over steel supports, $K = 1$ since this is the baseline for other cases. This indicates that support *connection* clamping to steel supports, particularly those at lap-down *side-lap connections*, restrains slippage at *side-lap connections* between supports. In the lap-up case, the *diaphragm stiffness* is significantly reduced and the ratio of *support connection flexibility* to *side-lap connection flexibility* is used to reduce the baseline *stiffness*. The wood support K is consistent with the ratio of *connection flexibilities* listed in *Standard* Section

D5.2.3. For a screw-screw or nail-screw combination, $\frac{S_f}{S_s} = \frac{1.5}{3} = 0.5$. In the *Standard*,

$K = 0.5$ is used even when the screw or nail is through the top flat and into the wood support where $\frac{S_f}{S_s} = \frac{3}{3} = 1.0$. Fasteners through the top flat and into the support are shown

in *Standard* Figure D1.1.4.3-1.

Perimeter details should be designed to minimize *purlin* or structural joist roll and to provide a stable path for shear flow into the *shear wall* or *moment frame*. Figure C-D5.1.1-1 illustrates purlin roll. Figure C-D5.1.1-2 provides one possible detail to control purlin roll.

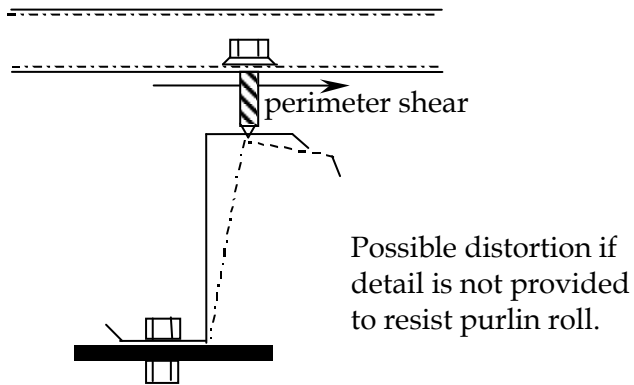

Figure C-D5.1.1-1
Example of Purlin Roll

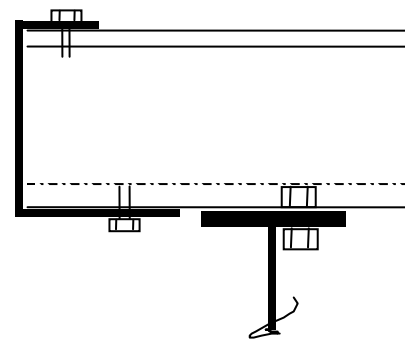

Figure C-D5.1.1-2
Detail to Control Purlin Roll

D5.1.2 Fluted Acoustic Panels With Perforated Elements

Perforations can affect all three items in the denominator of *Standard* Eq. D5.1.1-1. Luttrell (2011) provides a method to calculate this impact. The method addresses increased shear deflection in the *panel* elements and end warping. Shear deflection in a *panel* element is impacted by reduced shear *stiffness* across the perforated zone. End warping, D_n , discussed in the *Standard* Appendix 1 and its *Commentary*, is impacted by reduced *flexural stiffness* of the *panel* profile elements. The impact of perforations on I_x , D_n , and $\frac{s}{d}$ can be calculated and the necessary parameters for D_n and shear deflection in the panel elements can be obtained from the *panel* manufacturer.

The same fastener slippage constant, C , applies to *acoustic panels* and *non-acoustic panels* when fasteners are not in perforated zones. The effect of increasing s , D_n and C in the denominator of *Standard* Eq. D5.1.1-1 results in a decrease of *stiffness*, G' , and increased *diaphragm* deflection.

Standard Eq. D5.1.2-1 determines an equivalent width of a solid profile, s , for a perforated *panel*. The equivalent width provides the same shear deformation as a perforated element when subjected to the same *diaphragm* shear load. Note that this equivalent width, s , should not be used in the determination of D_n (see *Standard* Appendix 1) since different deformations are being considered – shear deformation in elements vs. element flexural racking at D_n .

If perforations are localized in *webs* of *panels* with depths less than or equal to 3 in. (76.2 mm) and the total perforation area is limited, the impact on I_x , s , D_n and G' can be small if not negligible.

A common application might illustrate the impact of perforations on G' : *Deck* type is WR (see *Commentary* Appendix 1, Table C-1.1a), $s = 8.19$ in. (208 mm) with no perforation; however, holes only are in the *webs* with $W_p = 1$ in. (25.4 mm), $c_p = 3/8$ in. (9.53 mm), and $d_p = 1/8$ in. (3.18 mm). These parameters lead to $p_o = 0.10$ (per Eq. C-1.6-1) and $k_{web} = 0.78$ (per Eq. C-1.6-2 while extrapolating *Standard* Eq. 1.5-5 results in $k_{web} = 0.72$). The modified

s is 8.75 in. (222 mm) (per *Standard* Eq. D5.1.2-1) or 6.8% greater than s with no perforation. The modified first denominator term in Eq. D5.1.1-1 is 3.79 vs. 3.55 and often of little consequence relative to the other denominator terms. In the example, D_n would also be modified (See *Standard* Appendix 1). $\gamma_c D_n$ is normally much larger than 3.79. A conservative example to investigate D_n in the denominator is: $L_v = 6$ ft (2 m), $L = 18$ ft (6 m), $t = 0.0358$ in. (0.909 mm), and with a fastener in each flute, so the modified s is 8.26 in. (210 mm) (per *Standard* Eqs. 1.4-7 and 1.6-3) and $\gamma_c D_n$ perforated is $0.9(4.30) = 3.87$ vs. $0.9(4.28) = 3.85$ unperforated – impact = 0.5%. The sum of the first two denominator terms is 7.66 vs. 7.40 or within 3.5% and this difference can be reduced by slippage, C, which could be about 7.5. Using this C, the denominator difference is about 2.0% (15.2 vs. 14.9). With a fastener in every other flute, $\gamma_c D_n$ perforated is $0.9(35.9) = 32.3$ vs. $0.9(35.8) = 32.2$ unperforated. The sum of these three terms is 43.6 vs. 43.3 or within 1% and dominated by D_n . Test data indicates $\frac{G'_{\text{test}}}{G'_{\text{theory}}}$ scatter much greater than this. The example's *web* perforation impact is negligible in both cases (< 2%).

The *stiffness* reduction due to perforations only in the *webs* and for *panel* depths less than 3 in. (76.2 mm) usually will not affect the *diaphragm* performance. This assumes the perforation pattern does not consume a large portion of the *web* area. Common *web* perforation patterns are less than 23% of the perforated zone.

D5.2 Connection Flexibility

Structural connection flexibility, S_f , and *side-lap connection flexibility*, S_s , provide the values of *connection flexibilities* necessary to calculate *diaphragm stiffness*, G' . These *flexibilities* are based on tests discussed in Luttrell (1981) and presented in SDI DDM03 (2004), Luttrell (1999a), and Nunna (2012). S_f and S_s indicate local distortion, strain, or slippage at fasteners in a *connection*.

D5.2.1 Welds Into Steel

D5.2.1.1 Arc Spot or Arc Seam Welds

The equations presented in *Standard* Section D5.2.1.1 for determining the *connection flexibilities* of arc spot or arc seam welds are adopted from SDI DDM03 (2004). Arc spot and arc seam welds are illustrated in *Standard* Sections D1.1.1 at supports and D1.2.2 at *side-laps*. *Standard* Eqs. D5.2.1.1-1 and D5.2.1.1-2 indicate that size of weld has negligible impact on the tested *connection flexibilities*. Arc seam welds at *side-laps* are not the same as *top arc seam side-lap welds*. By way of comparison, they have the same *flexibility* at a 2.33-in. (59.2-mm) long *top arc seam side-lap weld*, so there is relative consistency.

D5.2.1.2 Top Arc Seam Side-Lap Welds

The equations presented in *Standard* Section D5.2.1.2 for determining the *connection flexibilities* of *top arc seam side-lap welds* are based on the research sponsored by industry and reported by Nunna (2012).

Thickness affects the *connection flexibility* of a *top arc seam side-lap weld* while the weld

length, L_w , may have less impact. This is consistent with arc spot welds (*Standard* Section D5.2.1.1) where weld size has no impact. The *top arc seam side-lap weld* test data included ductile steels with a minimum $F_y = 31.9$ ksi (220 MPa) and a maximum $F_y = 54.2$ ksi (375 MPa) and lower ductility steel having a maximum tested value of $F_y = 105$ ksi (725 MPa). Therefore, the *Standard's connection flexibility* equation applies over the acceptable range of Chapter D.

D5.2.2 Screws Into Steel

The *Standard* Eq. D5.2.2-1 is for thick supporting material and is adopted from SDI DDM03 (2004). The equation only considers the *bearing* deformation of the *panel* against screw. For thin supports, tilting can be considered rationally by linear interpolation between *Standard* Eqs. D5.2.2-1 and D5.2.2-2 that define the probable limits of S_f . This is a consideration in cold-formed steel framing. Since the original research determining S_f did not include such supports, the following rational engineering judgments are provided.

For strength determined in accordance with *Standard* Section D1.1.2, the *connection flexibility* is determined as follows:

For $t_2 \geq t_3$, use *Standard* Eq. D5.2.2-1

For $t_2 < t_3$ and $t_2 \geq t_1$, linearly interpolate as shown in Figure C-D5.2.2-1

For $t_2 < t_1$, *Standard* use Eq. D5.2.2-2 based on $t = t_2$

where

t_1 = *panel thickness*, in. (mm)

t_2 = *support thickness*, in. (mm)

t_3 = *support thickness* where P_{nf} controlled by tilting or *bearing* of the screw against the support controls for the *panel thickness*, t_1 in. (mm)

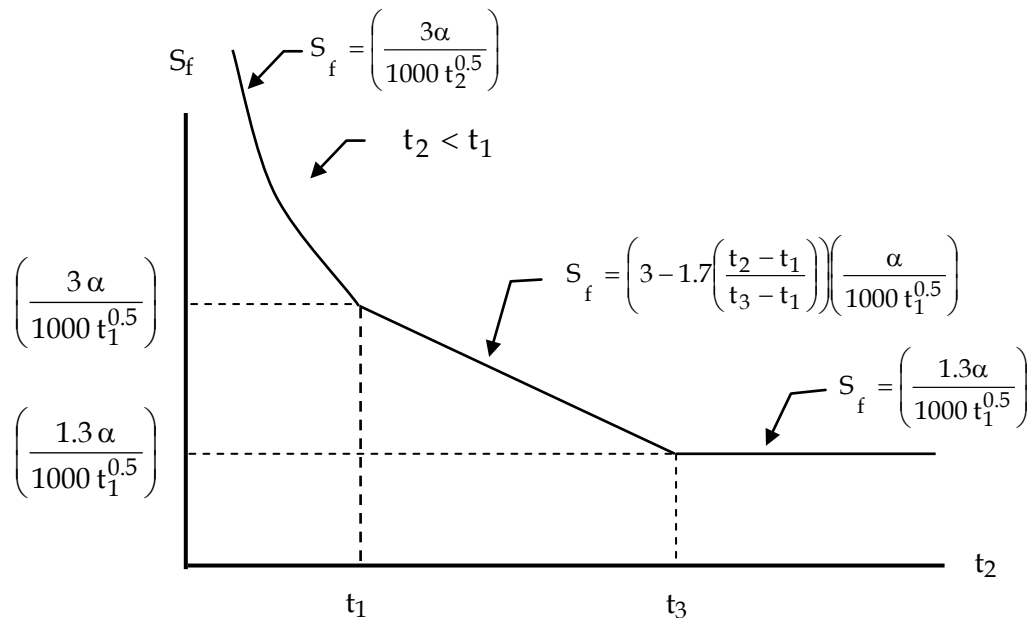

Figure C-D5.2.2-1 Support Screw Flexibility

The *Standard's side-lap connection flexibility* Equation D5.2.2-2 is not limited to #12 screws and is commonly applied to #10 screws and # 8 screws. SDI DDM03 (2004) includes *nominal strength [resistance]* research on #8 and #10 screws, and discusses that the slope of the *load-slip* curve was virtually constant for all diameters at lower *loads*. Choice of screw size, thread and point type depends on the application.

D5.2.3 Wood Screws or Nails Into Wood Supports

The *Standard* equations for determining the *connection flexibility* of screws or nails into a wood support are adopted from Luttrell (1999a).

S_s is not provided for nails, and nails typically are not used in *side-lap connections* that are not into the support.

D5.2.4 Power-Actuated Fasteners Into Supports

A designer can find the *connection flexibility* equations for specific *power-actuated fasteners* listed in SDI DDM03 (2004) and its appendices or can consult the fastener manufacturer for test data on these and other proprietary fasteners that conform to *Standard* Section D5.2.6.

D5.2.5 Non-Piercing Button Punch Fasteners at Steel Panel Side-Laps

The traditional non-piercing button punch requires a manual or automated crimping tool to draw a “dome-like” button into an *interlocking top side-lap connection*.

When determining G' , n_s should not be neglected (even when it must be neglected for *diaphragm nominal shear strength [resistance]*) because the contribution of *side-lap connections* is greater at the *service load* level and can be depleted near ultimate *load* because of slip. Test data calibration for deep or *cellular deck* fits better when non-piercing button punch contribution is considered for *diaphragm stiffness* but neglected for *diaphragm shear strength*.

D5.2.6 Other Fasteners – Flexibility Determined by Tests

For fasteners not included in *Standard* Sections D5.2.1 to D5.2.5, the *Standard* permits *connection flexibility* to be determined through tests conducted in accordance with *Standard* Sections E1.1 and E1.2. AISI S905 includes *connection flexibility* test methods.

Support *thickness* dominates the support *connection flexibility*, S_f , even though other mechanical properties may affect *connection flexibility* as well. As support *thickness* approaches the sheet *thickness*, support *connection flexibility*, S_f , will approach S_s .

Several manufacturers have developed proprietary tools and *side-lap connections* to provide significant *nominal strength [resistance]* per *connection*, and some connections fully penetrate and fold the steel to form an interlock. These proprietary *connection flexibilities* must be tested in accordance with *Standard* Section D5.2.6.

D5.3 Stiffness of Cellular Deck

D5.3.1 Cellular Deck Without Perforations

The equations in *Standard* Section D5.3.1 are adopted from Luttrell (SDI, 2013). Bagwell (2008) evaluated the stiffness equation in an earlier edition, Luttrell (2005). Warping distortion in the bottom plate is negligible and tests indicate that warping in the top *deck* is

also negligible. The inherent torsional restraint of the closed *cellular deck* resists end warping and D_n is not present in *Standard* Eq. D5.3.1-1. The bottom plate efficiently resists a significant part of the shear force. *Standard* Eq. D5.3.1-1 modifies *Standard* Eq. D5.1.1-1 and addresses both factors. The distribution of *shear resistance* between the bottom plate and top *deck* can be calculated based on shear deflection compatibility at the longitudinal lines of *cellular deck connections*. *Standard* Eq. D5.3.1-2 adjusts for *load sharing* and measures the shear flow and *stress* in the top *deck*. The numerator, t , of *Standard* Eq. D5.3.1-1 is based on the top *deck thickness* of the *cellular deck*.

Slippage at *side-lap connections* over and between supports can dominate deflection and depends on the *connection flexibilities* (and *thicknesses*) at the *side-lap*.

D5.3.2 Cellular Deck With Perforations

Perforations in either the bottom plate or top *deck* affect the shear distribution between the two elements. The more common condition is perforations in the bottom plate only. Luttrell (SDI, 2013) provided a method to calculate the shear distribution between top and bottom elements and the resultant G' . The method considers the increased shear strain due to perforations by calculating an equivalent increased element length for a non-perforated element. *Standard* Eq. D5.3.2-1 includes this method and reduces to *Standard* Eq. D5.3.1-2 when there are no perforations.

D5.4 Stiffness of Concrete-Filled Diaphragms

D5.4.1 Stiffness of Structural Concrete-Filled Diaphragms

The equations for alternative unit systems have been provided for *structural concrete stiffness* contribution, K_3 , in the *Standard*. *Standard* Eq. D5.4.1-1 has additive components and is unit-sensitive. Therefore, a compatible unit system should be used. For example, if $f'_c = 3000$ psi and $d_c = 2.5$ in. are used in *Standard* Eq. D5.4.1-3a,, $K_3 = 2377$ kip/in. Therefore, the U.S. customary units that produce kip/in. ($E = \text{ksi}$ and $t, s, d = \text{in.}$) should be used for the first term in *Standard* Eq. D5.4.1-1 or *Standard* Eq. D5.4.1-2. Similarly, if $f'_c = 21$ MPa and $d_c = 65$ mm are used in *Standard* Eq. D5.4.1-3b, $K_3 = 430,000$ kN/m, and the SI units that produce kN/m ($E = \text{MPa}$ and $t, s, d = \text{mm}$) should be adopted for the first term. C is unitless in *Standard* Eq. D5.1.1-2. In SI units, G' often is adjusted and published as kN/mm.

Although the theories behind *Standard* Eqs. D5.4.1-1 and D5.4.1-2 apply to any support type that has a defined S_f and allows calculation of C in *Standard* Eq. D5.1.1-2, the research is based on tests of the *structural concrete-filled diaphragms* on hot-rolled shape supports. This includes both large-scale *concrete slab* tests and *connection flexibility* tests. The *Standard* limits applicability to shapes or steel joists whose top chord *thicknesses* are greater than or equal to 0.1 in. (2.5 mm). Testing is required for other cases.

D5.4.2 Stiffness of Insulating Concrete-Filled Diaphragms

The same analytical method is used for both *structural* and *insulating concrete*.

D6 Diaphragm Flexibility

Flexibility is the inverse of *stiffness*. *Stiffness*, G' , or *flexibility*, F , can be used to calculate in-plane deflection in accordance with *Standard* Section C3. The *Commentary* on Section E1.2 discusses the *diaphragm* system in the *Tri-Service Manual* (TM 5-809-10, 1985) as an acceptable method to determine *diaphragm nominal strength* [resistance] and *stiffness* by tests. The equations in the *Tri-Service Manual* provide *diaphragm flexibility* and are unit-sensitive.

E. DIAPHRAGM NOMINAL SHEAR STRENGTH [RESISTANCE] PER UNIT LENGTH AND STIFFNESS DETERMINED BY TEST

Standard Chapter E outlines the testing methods and test requirements. Testing objectives are discussed in *Standard* Section E1.2. The testing objective should establish the test matrix, and the test results should determine the applicable range of parameters, ultimate strength of *diaphragm* or *diaphragm connections*, and *stiffness* and *flexibility* of *diaphragm* or *diaphragm connections*, as required by the testing objective.

The *available diaphragm shear strength* [*factored resistance*] and *stiffness* can be based on tests in accordance with:

- (a) *Standard* Section E1, which is used for a *prototype diaphragm system* based on an analytical method with considerations of parameters outlined in *Commentary* Section E1.2 and AISI S907; or
- (b) *Standard* Section E2, which is for a *single diaphragm system*.

Standard Chapter E does not preclude acceptance of any products (or fasteners) and research or tests that preceded the *Standard* and thus might not conform to the *Standard's* requirements, where the research or tests were performed under the direction of an engineer in accordance with acceptable practices.

E1 Strength and Stiffness of a Prototype Diaphragm System

E1.1 Test Protocol

The tests should be based on existing AISI Test Standards wherever possible. Some ASTM Standards are permitted for small-scale tests for particular *support connections* into non-steel supports.

Seasoned and dry wood is required to eliminate the greater variation associated with wood to establish a baseline and to help isolate the contribution of other parameters. Design should consider reductions in *nominal strength* [*resistance*] and increases in *connection flexibility* for *structural connections* in wood supports due to less seasoning and greater moisture. Various reduction factors are provided in AWC NDS.

E1.2 Design Using Test-Based Analytical Equations

Existing *diaphragm* system methods (SDI, 2004; MCA, 2004; TM 5-809-10, 1982) are test-based and may be used to establish analytical equations or as starting points to extend the stated limits of these methods.

Since the existing analytical methods already have defined the contributions of many parameters and the controlling *limit states*, those parameters and *limit states* do not have to be considered in the development of test matrices unless the desired application range is outside the established limits. The number of tests to extend these limits typically is minimal, and calibration could include the entire testing database verifying the existing method plus any extension tests. AISI S100 Section J4 allows tests in lieu of analytical equations for screws. *Standard* Section E1.2 similarly allows testing of any fastener or *connection* even when the analytical method of *Standard* Chapter D applies. For some proprietary fasteners, the provisions in *Standard* Chapter D may be applicable. However, the manufacturer has the option to refine the *nominal strength* [*resistance*] or *connection flexibility* of the fastener by tests.

The *Standard* does not address the development of a new analytical method, but it does not exclude that option. Alternative analytical methods to establish *diaphragm nominal shear strength [resistance]* and *stiffness* equations should be developed under the supervision of an experienced professional and should be confirmed by sufficient tests. The method should define the controlling *limit states*, application limits of parameters, and *safety* and *resistance factors*. Since the number of required tests depends on testing objectives, the number of required tests to develop a new analytical method typically requires more tests than that required to extend an existing method. The *safety* and *resistance factors* for new analytical methods are determined in accordance with *Standard* Section E1.2.2. Alternative analytical methods and new tests should also meet building code requirements and be acceptable to the design professional and other authorities having jurisdiction.

In any analytical method, theoretically, all parameters must be considered. However, since some of the parameters may not be pertinent to the method or test scope, those parameters can be eliminated. A list of probable parameters is contained in AISI S907. Some parameters are included in each test assembly, such as span, profile, *thickness*, and mechanical properties. The contributions of these essential parameters are considered in tests that are constructed to evaluate other parameters. More than two parameters can be included in one test where their contributions are defined in an existing system method equation and the test combination for these parameters is within the method's established limits. The contribution of parameters being purposely evaluated must be significant in the test or the result may be trivial. *Commentary* Table C-E1.2-1 summarizes the parameters whose contributions are defined in each of the listed method or model's analytical equations.

Although other effects are possible, profile geometry can affect the following:

- (a) The number, type and size of acceptable fasteners,
- (b) The ability to end-lap,
- (c) *Buckling resistance*, and
- (d) The response to warping shear.

Fastener dimensions and mechanical properties might include but are not limited to shank dimensions, head or washer type, shank hardness, and *tensile strength*. The number of required tests will depend on the test objective; e.g., the desired application limits of the fastener in the analytical model.

Testing can establish either a constant, trivial or asymptotic value for certain parameters and the results can use those values in the *nominal strength [resistance]* or *flexibility* analytical equations, which define the *panel*, support, and *connection* interaction in the *diaphragm* system. It is acceptable to set a singular, i.e. minimum or maximum, value for the contribution of a parameter. Examples include:

- (a) Constant *side-lap connection nominal shear strength [resistance]*, P_{ns} , for all values of t and F_u , and
- (b) The benefit of increasing F_u for a particular fastener is determined to be negligible after some value of F_u .

A particular example of (a) is selecting a single value for P_{ns} in *Standard* Section D1.2.6 for a non-piercing button punch.

Where the method of *Standard* Chapter D is used to calculate *diaphragm* shear strength and *stiffness* and all parameters (other than those *connections* to be tested) conform to *Standard* Chapter D, small-scale tests can be performed to define the *nominal strength [resistance]* and

flexibility of the *connections* that are not already defined. The *connection strength* and *connection flexibility* equations will include the contributions of the essential parameters listed in *Standard* Table E1.2-1, as applicable to the research scope. Although large-scale tests in accordance with AISI S907 and no small-scale tests are the acceptable option, the more common approach is to only use small-scale tests in accordance with *Standard* Sections D1.1.5 and D1.2.7. *Standard* Section E1.2.2(a) sets additional restrictions on the *connection nominal strength [resistance]* equation, so the confidence in *connection strength* equals or exceeds that of the *Standard* Chapter D analytical system. Application of *Standard* Section E1.2.2(a) requires reduction of the *nominal strength [resistance]* equation and recalibration where an initial calibration generates a *resistance factor* less than that of the *diaphragm* system for the same *load* effect and construction type. To use the limits of an existing method for a *diaphragm* system, the new *connection* test matrix must encompass those same limits.

To use the theory of an existing method with limited new large-scale tests, the mean, P_{mv} of all large-scale test data leading to the original calibration of the theory plus any new test data should not shift significantly. This indicates that the accuracy of a newly developed *support* or *side-lap connection nominal strength [resistance]* equation is in line with other fastener equations provided in the existing method. This also indicates that:

- (a) Inclusion of the new *connection* equation would not significantly affect the calibration leading to *Standard* Table B1.1 or other test-based theories, and
- (b) The existing system *safety* and *resistance factors* are valid for the new data.

An analytical method includes the interaction of *support* and *side-lap connections* and the impact of the *panel* to define a *diaphragm* system's *nominal shear strength [resistance]* per unit length controlled by *connections*, S_{nf} . The method also defines a separate limit state, the *nominal shear strength [resistance]* per unit length controlled by *panel* buckling, S_{nb} . Existing analytical methods should not be mixed to calculate either limit state, S_{nf} or S_{nb} , unless the combination is considered a new analytical method. However, when determining S_{nf} , insertion of a test-based analytical equation for *connection nominal strength [resistance]* from one existing analytical method into another analytical method provides the same result as small-scale tests and is acceptable as long as the reliability of the borrowed *connection* equation is consistent with that of the primary analytical method and all other provisions of Section E1 are met. The stability analytical method leading to S_{nb} defines a separate *limit state* and does not mix methods if it is unchanged. Although it is rarely done, it should be acceptable to use S_{nf} from one existing model and S_{nb} from an alternate model as long as the correct *safety* or *resistance factor* is used for each limit state. Large-scale testing may still be required to confirm the system application in accordance with Section E1.

To minimize the number of tests or *load* tables for design applications, it is conservative to use lightweight *structural concrete* test results for normal weight *structural concrete available strength [factored resistance]* in design, or to use lesser *concrete compressive strength*, f'_c , test results for greater *compressive strength* in design.

Parameter	SDI & MCA Method ²		Tri-Service Method ^{1, 3}	
	Qualified	Comment	Qualified	Comment
Span, L_v	Yes		Yes	
Span continuity, L & $\frac{L}{L_v}$	Yes		Yes	
Panel profile	Yes	Limits defined	Yes	Limits defined
Cellular Deck	Yes	Limits defined	Yes	Limits defined
Panel uncoated thickness, t	Yes	Limits defined	Yes	Limits defined
Panel properties, F_u & F_y	Yes	Equations for pre-qualified fasteners define limits	No	Variation not defined. See Note ¹
Panel cover width, w	Yes		Yes	
Support thickness	Yes	See Chapter D for impact on P_{nf}	Yes ⁴	Assumes panel bearing controls
Support tensile strength, F_u	Yes		No	
Panel side-lap fastener type & size, P_{ns}	Yes	Equations for pre-qualified fasteners define limits	Yes	Welds & button punch only
Side-lap fastener number, n_s	Yes		Yes	
Support fastener type & size, P_{nf}	Yes	Equations for pre-qualified fasteners define limits	Yes ^{1,3}	Limits defined. One-size weld and lower value F_u (55 ksi).
Support fastener location	Yes	Included in α , α^2	Yes	Included in S
Panel end lap detail	Yes	See Note ²	Yes	Reductions defined
Reinforcing accessories	No		Yes	Limits defined
Edge detail parallel to panel	Yes	Included at S_{ne}	Yes	
Limits for out-of-plane buckling	Yes	Limits defined	Yes	Limits defined
Fill type and thickness	Yes	Limits defined	Yes	Limits defined
Fill mechanical properties, f'_c	Yes	Limits defined	Yes	Limits defined
Insulation - panel & support	Yes	Limits defined	No	

Note:

- 1 The Tri-Service method is empirical and provides the *allowable strength [resistance]*. The *safety factor* is 3 for panels with and without fill. The support weld requires an effective diameter, d_e in D1.1.1, of ½ in. (13 mm) for arc spot welds or 3/8 x 1 in. (9.50x 25.4 mm) for arc seam welds. The empirical equation does not include panel F_y or F_u as parameters, and a minimum $F_y = 40$ ksi (275 MPa), and a minimum $F_u = 55$ ksi (380 MPa) are required. That material contribution is attributed to all steel in the equation.
- 2 Some end-laps were included in the large-scale tests, and this is partly covered in the value of P_{nf} . If the value P_{nf} at end-laps is determined, then the method addresses the impact.
- 3 The empirical formulas are limited to particular *connections* and sizes. However, the methodology can be applied after the contributions for other *connections* are defined and verified by tests. This contribution is permitted to include fastener size and type, panel thickness and mechanical properties. With sufficient tests, lesser *safety factors* can be justified. However, the more common approach adopts the existing *factor* as discussed in the *Commentary* of this Section.
- 4 3/16 in. (4.76 mm) minimum support thickness is required. Lesser thickness requires tests.

The *Tri-Service Manual* (Department of Army, 1985) provides design equations for determining *allowable strength* and *flexibility* of *diaphragm configurations*, and includes a system relationship between *support* and *side-lap connection* strengths. For *diaphragm configurations* whose parameters other than *connection(s)* conform to the limits of the analytical method given in the *Tri-Service Manual* (Department of Army, 1985), the following procedures can be followed to determine the *connection* strength and *flexibility* of a new *connection* to be used in the analytical method:

- (a) Perform small-scale tests using AISI S905 to determine the *nominal strength [resistance]* and *connection flexibility* of all *connections* that are not already defined in the method. The *connection* strength and *flexibility* equations will include the contributions of the essential parameters as applicable to the research scope, including those that affect constant, K (in Section 5-6 of the *Tri-Service Manual* (TM 5-809-10, Eq. 5-12)) for *support connections*. K requires large-scale tests (see item (b) below) which determine constants C2 and C3 (in Section 5-6 of the *Tri-Service Manual* (TM 5-809-10, Eq. 5-13 and Eq. 5-14)) that are required for *side-lap connections*.
- (b) Perform large-scale tests per AISI S907 to complete the test matrix, and analyze the results to determine the constants mentioned in (a).
- (c) Modify the existing equations in the *Tri-Service Manual* for *allowable diaphragm* shears and *flexibility* factors so the test results conform to the *Standard's* Sections E1.2.1 and E1.2.2(c). Units should be consistent in this analysis.
- (d) Develop *load* tables and *diaphragm flexibilities* using the *safety* and *resistance factors* determined using *Standard* Section E1.2.2. Tables must state any application limits.

E1.2.1 Test Assembly Requirements

If *diaphragm nominal shear strength [resistance]* is controlled by a tested edge *connection* or detail, the *interior panel diaphragm shear strength* would not be established to evaluate analytical equations for the *panel*. This implies that test assembly details should isolate the system contribution of the *diaphragm's panels* and *connections* by eliminating nonessential parameters or details that could otherwise control *diaphragm nominal shear strength [resistance]*. Partial-width *panels* should not be used to complete a test assembly unless the partial-width *panel* is fastened to supports and *stitch-connected* to the full-width *panel* to develop the same *strength* as a full-width *panel* and its *connections*. *Standard* Section D1 shows that the cover width impacts *strength* and *stiffness*. As an example, more side seams are present for slip to occur in partial-width or narrow *panels*, and the section modulus of the *support connection* cluster is smaller in narrow *panels*. The number of full-width *panels* should conform to the requirements of AISI S907.

A *diaphragm* test should consider that total shear (100%) has to flow into or out of the *diaphragm* through the longitudinal and transverse perimeter *support connections*. The analytical method in *Standard* Chapter D addresses this requirement at Eqs. D1-2 and D1-3 by checking the resistance to required shear flow at *panel* ends and edges. Eqs. D1-1 and D1-2 (where applicable) cover the field *diaphragm panel connection resistance*. When these limits plus *out-of-plane buckling* concerns are met, the *panel* design for tests is considered satisfactory.

Where the test objective is to establish the *diaphragm* strength per unit length of the edge detail, the edge condition should control the *diaphragm* failure. Otherwise, sufficient

connections should be provided parallel to the *panel* span to direct the *strength* limit to the *diaphragm* field. In lieu of edge detail testing, the perimeter or edge *connection* parallel to the *panel* span can be designed to transfer forces without limiting *diaphragm nominal shear strength [resistance]* or *stiffness*. Many engineers consider that the addition of more fasteners and thicker accessories at the edge does not significantly impact the total project installation cost, and this approach can avoid the edge detail's control of the system *resistance*.

Where the tested *nominal strength [resistance]* is limited by a parallel edge *connection* or detail, the designer is cautioned to not apply the tested *stiffness* or *strength* to the entire *diaphragm* design. Local warping in flashings or accessories, support distortion or roll, and fastener slippage at perimeter details can provide greater proportionate impact relative to a few *panels* in a test frame than they will in a larger structure.

Each *configuration* has one set of parameters. Absolute repeatability of some parameters within different test specimens of similar *configuration* is not possible, but such parameters should be held reasonably close to study the contribution of other tested parameters. An example is concrete *compressive strength*, f'_c , when determining the contribution of fill thickness while the impact of f'_c is not already defined by the method.

Where a new *panel* or fastener is being developed and end-laps are a feature of both the *panel* used in the test and the testing objective, the test should demonstrate that end-laps can be made and that *connections* can be installed. The *connection nominal strength [resistance]* at *panel* ends can be determined using an existing analytical method provided the *connection strength* equation is applicable for both end-laps and butt *joints*. Since designers may not know whether end-laps or butt *joints* will be installed on projects, it is rational to select the lesser *nominal strength [resistance]*. Manufacturers commonly use only one *connection strength* in load tables including *interior support connections*, and butt *joint* or end-lap *support connections* by using the least of all these support *connection nominal strengths [resistance]*, P_{nf} .

Parameters that are not defined by existing method equations require the minimum number of tests specified in AISI S907 or S905, as applicable, to establish each parameter's contribution over the desired range. Historically, a minimum of three tests is required to establish linearity or non-linearity of contribution for each parameter, but this depends on the test objective and the desired application range. As long as the contribution of each is not trivial, more than one undefined parameter can be isolated and included in a *configuration*.

A large-scale test evaluates the system effect of *connections* and can detect the weakest link of the *diaphragm* system. Analytical methods include the system contribution of *support* and *side-lap connections*. The *Commentary* of AISI S907 provides minimum relative contribution requirements for *connections* to ensure that interaction is present and the contribution of each *connection* is measurable while *nominal strength [resistance]* equations are tested. The tested *connections* should be as specified for the test assembly. Some variance is acceptable at welds as long as the overall uniformity of *connections* remains. The *Standard* provides rules to establish reasonable uniformity.

If panel application is limited to single-span, single-span tests should be performed. Whenever possible, three or more test spans are preferred for confirmation of multiple-span *diaphragms*. Two span test results could be permitted for multiple-span *diaphragms*

where available test frame size is limited. Many manufacturers apply three span tests to a greater number of spans for both *diaphragm shear strength* and *stiffness*. Most end warping occurs at *panel* ends. Generally, the impact of end warping is greater in single- or double-span tests than in three span tests when all the variables are kept the same other than *panel* length, L . For this reason, direct use of the tested G' from a single- or double-span test is conservative. However, if the existing model considers the variation of span number, G' can be calculated when applying single-span test confirmations to multiple-span applications.

If a new analytical method is being developed and the impact of continuity is not defined by the tests, the design engineer should consider the continuity impact using an existing analytical method before applying single-span test results to multiple-span applications or multiple-span test results to single-span applications.

E1.2.2 Test Calibration

Calibration of an analytical equation for a *diaphragm* system should be based on AISI S100 Section K2.1.1(b). However, the number of tests required by the test standards listed in *Standard* Section E1.1 for particular testing objectives could vary from the requirement in AISI S100 Section K2.1.1(b) and *Standard* Section E1.1 controls. The calibration method provided in *Standard* Section E1.2.2 is an application of AISI S100 Section K2.1.1(c) that is specific to *diaphragm* systems. A detailed discussion of *diaphragm*-specific calibration is included in Section B1.1. See AISI S100 *Commentary* Section B3.3 for a discussion of probability analysis concepts and calibration of *resistance factors*.

AISI S100 Section K2.1.1(a) requires that deviation of any individual test result from the average value obtained from all tests should not exceed 15 percent. When this is not satisfied, additional testing is required. However, AISI S100 Section K2.1.1(a) only applies in *Standard* Section E2. To develop analytical equations through tests, the *Standard* adopts AISI S100 Section K2.1.1(b) with these modifications:

- (a) Relax the scatter criterion due to repetition of components and contributing parameters in each *diaphragm* test while recognizing the probable variance in the large-scale test due to installation quality at these repeating components (weakest link and redistribution potential), and
- (b) Allow the calibration process to provide the necessary *safety* and *resistance factors* with restrictions on $\frac{R_{t,i}}{R_{n,i}}$ while retaining the C_c requirement of AISI S100 Section K2.1.1(b).

Reasonable *resistance factors* have been obtained using this approach to verify that a theory adequately predicts tested performance. Each large-scale test evaluates the same analytical equation, so each test is a repeat verification. The AISI S100 Section K2.1.1(a) requirement for three identical specimens does not apply in AISI S907 since there can be many *connections* and *panels* in each test. Note that in AISI S100 Section K2.1.1(c), n is the total number of large-scale tests in the test program verifying the analytical method. n is not the total number of *connections* in all tests.

If large-scale tests are selected to verify an analytical method, $S_n \text{ test} / S_n \text{ theory}$ for each test should be consistent with the tests used to develop *Standard* Table B1.1. Analysis of the test data in DDM01 (SDI, 1981) reports using the theory of the *Standard* creates the scatter

of 0.58 to 2.03 while Bagwell (2008) reports the scatter of 0.81 to 1.39 for *cellular deck*. The ratio limit of 0.6 in *Standard* Eq. E1.2.2-1 ensures that most of the tests constructed in a laboratory provide more *resistance* than the theoretical *factored strength*, ϕS_n , that might be used in design, and avoids *resistance* equations significantly over predicting tested performance. This value also takes into consideration the historical scatter in *diaphragm* tests. The engineer in charge of testing must determine whether a testing anomaly exists to discount a value lower than 0.6. If an anomaly does not exist, the test should be repeated to determine if a flaw exists in the *resistance* equation and if the equation reasonably predicts all regions of the proposed parameter range. The engineer should determine if other tests that support the equation in the same range of parameters can offset a low ratio. By following the restrictions requiring a ratio greater than 0.6 and n conforming to AISI S907, the calibration process outlined in *Standard* Section E1.2.2 is consistent with the intent of AISI S100 Section K2.1.1(b).

The *Standard* requires that *connections* be as specified but recognizes that size variance will exist at welds. Therefore, S_n theory is based on the average measured weld sizes at support and *side-laps*, but the assembly weld size scatter must conform to the range limits of *Standard* Section E1.2.1. Use of the average is consistent with the *diaphragm* system effect and redistribution potential of that system.

The method of measuring deflection within a test will affect the calculated value of $G'_{i \text{ test}}$. $G'_{i \text{ test}}$ often is the secant value of a *load-deflection* curve in the lower range of *loads*. Since the difference in deflection values at defined *loads* is in the denominator and can be a very small number, very slight errors in deflection readings can have a large impact on $G'_{i \text{ test}}$. If deflections (leading to $G'_{i \text{ test}}$) or *panel* parameters (leading to $G'_{i \text{ theory}}$) are not measured accurately, an individual ratio, $\frac{G'_{i \text{ test}}}{G'_{i \text{ theory}}}$, could be less than 0.50. However, the

Standard sets 0.50 as the lowest acceptable ratio to ensure a consistency between measured and calculated stiffness values, and most existing data conform to this requirement.

Generally, tests should result in an average value of all $\frac{G'_{i \text{ test}}}{G'_{i \text{ theory}}}$ greater than 0.7 or the

analytical method should be revised. Because of the potential scatter, a significant number of tests may be required to bring the desired balance, and it is reasonable to consider new tests verifying an existing theory as extensions of the previous tests. The new test results can be added to the published existing database. Tested or calculated G' is, at best, a good approximation of *stiffness* in an actual structure's *diaphragm*.

The target reliability index, $\beta_o = 3.5$, is used in *LRFD* and $\beta_o = 4.0$ is used in *LSD* because AISI S100 Section K2.1.1 requires this for *connections*. $\beta_o = 2.5$ is permitted when wind plus dead *load* causes *diaphragm* shear in *LRFD* and by extension in *ASD*. These β_o options might not apply to steel *deck* with concrete fill or *panels* on wood support, and this is shown in *Standard* Table E1.2.2-1. For *diaphragms* with *structural concrete* fill, β_o should not be less than the β_o allowed for *concrete* shear in ACI 318.

The research by Nowak and Szerszen (2003) reported that for *structural concrete* slabs, $F_m = 0.92$; $V_F = 0.12$; $P_m = 1.02$; $V_p = 0.06$; $M_m = 1.35$ to 1.12 ; and $V_M = 0.102$ to 0.042 for ready mix *concrete* 28-day cylinders with $f'_c = 3$ ksi and $f'_c = 6$ ksi, respectively. However,

in a separate study relating in-situ f'_c to 28-day cylinder f'_c , Petersons (1968) suggests that the in-situ strength is approximately 90% of the cylinder f'_c . Tabsh (1997) reports $\beta_o = 3$ for *structural concrete* slabs in shear. Statistical data, $F_m = 0.9$; $V_F = 0.10$; $M_m = 1.1$; and $V_M = 0.10$, are selected based on these reports recognizing that the *diaphragm* consists of steel *deck* and *connections* in addition to *concrete* fill. The other calibration values, P_m and V_p , are calculated from the test data.

Structural concrete fill dominates *diaphragm nominal shear strength [resistance]*. However, the system β_o is conservatively chosen to be greater than or equal to that allowed for *concrete* slabs and that allowed for steel *connections* in AISI S100.

Standard Eqs. D4.3-1 and D4.3-2 indicate that both *deck* and *lightweight insulating concrete* fill contribute to *diaphragm shear strength*. The contribution of each component to the total strength can be significant. AISI S100 Table K2.1.1-1 lists statistical data for determination of *resistance factors* using AISI S100 Eq. K2.1.1-2 for various *deck connections*. The statistical parameters for *insulating concrete* fill should not deviate greatly from those of *deck connections*. For simplicity, the *deck connections* statistical data in AISI S100 Table K2.1.1-1 is used to calibrate the combination of *deck* and *lightweight insulating concrete*. Consistent with AISI S100 Section K2.1.1, statistical data can otherwise be determined by statistical analysis.

The statistical data in *Standard* Table E1.2.2-1 for wood-supported *diaphragms* was determined based on rational engineering after a review of Rosowsky (2005) and Bulleit (2007). The data in *Standard* Table E1.2.2-1 provide reasonable agreement with *Standard* Section D1.1.4.1.

In large-scale tests for extending or verifying existing theories, C_p may be taken as 1.0 because the entire theory database can be used to define n in AISI S100 Eq. K2.1.1-4. The *Commentary* of AISI S907 includes a discussion of the historical and extensive testing performed on existing analytical methods.

E1.2.3 Laboratory Testing Reports

When developing analytical equations, two separate reports may be produced:

(1) Laboratory Testing Report

This report provides the required information defined in AISI S905 and AISI S907. The size and *nominal strength [resistance]* requirements for *connections* include the visible diameter for welds and the *nominal tensile strength [resistance]* and hardness for screws and *power-actuated fasteners*. When welds are used, report electrode size, *tensile strength* and type, weld settings, and welding time. Note air gaps, ambient conditions, support *thickness*, and whether qualified welders were used. Also, note whether large-scale tests conform to the prequalification procedures used in small-scale tests if applicable.

Weld procedures in tests do not define the exact procedure required for construction site installations because those conditions can be entirely different from laboratory conditions. Often, welder preferences and prequalification procedures required by the *applicable building code* will establish what is required for suitable welds on construction sites.

(2) Engineering Report

This report justifies the analytical equation(s), responds to the requirements of *Standard* Section E1, and provides information for future researchers, designers and building officials. This report might include:

- (a) Developed analytical equations,
- (b) Calculated *nominal shear strength* [*resistance*] and *stiffness* for each test using the analytical equation,
- (c) Table of $\frac{S_{ni \text{ test}}}{S_{ni \text{ theory}}}$ and $\frac{G'_i \text{ test}}{G'_i \text{ theory}}$ for each test,
- (d) Calculated *safety* and *resistance factors* or statement that established system *factors* apply,
- (e) Applicable range limits of the developed equation(s), and
- (f) Certification that the equation development and calibration conform to the *Standard* and were performed under the direction of a professional engineer.

E2 Single Diaphragm System

A *single diaphragm system* is defined in *Standard* Section A1.3. A *single diaphragm system* has one *configuration* with no variation in construction parameters.

E2.1 Test System Requirements

The specified *diaphragm system* must be tested whether isolating a detail or verifying the field of *diaphragm* construction. The limits in *Standard* Sections E2.1(b) and E2.1(c) recognize that tested mechanical properties typically vary from specified values. However, tested values should be reasonably close to those specified, and repeated tests should have consistent materials and construction. Adjustments are required in *Standard* Section E2.4 to account for variance of tested material properties from specified properties. Material controls and design adjustments are consistent with AISI S100 Section A3. Because the tests repeat the same construction and installation techniques, and the material is taken from the same batches where applicable, repeatability should be more readily achievable than testing in Section E1. Therefore, the test deviation requirements of AISI S100 Section K2.1.1(a) are imposed.

A “support representative of the design” does not have to be the same member size that will be used on a particular project, but the tested dimension should be adequate so that the same type of failure will occur at the *connection*; e.g., *bearing* of *panel* against and slotting around the fastener. The requirement to test dry and seasoned wood supports does not apply in *Standard* Section E2. The wood support should be representative of the design and application.

E2.1.1 Fastener and Weld Requirements

Size variation should be expected in the installation of specified welded *connections*. However, care should be taken to closely achieve the desired weld sizes in test construction. A prequalification procedure is suggested to achieve the desired sizes. The *Standard* provides acceptable limits and requires adjustment based on the smallest measured dimensions. Design based on a set of smallest values recognizes distribution

potential and that the smallest *connections* should be the weakest link. The number of smallest welds, 10, is a rational judgment. This approach slightly differs from the average value that is used to calculate S_{ni} theory in *Standard* Section E1.2.1. *Standard* Section E1.2.1 is testing a theory, while *Standard* Section E2.1.1 is defining the *nominal shear strength [resistance]* and *stiffness* of a particular *diaphragm* construction. Slightly greater quality control is also required in *single diaphragm system* tests.

E2.1.2 Concrete Requirements

Depth and *compressive strength* variation relative to specified values should be expected at *structural* or *insulating concrete* fill (slabs) over *deck* in individual or repeat tests. The *Standard* provides acceptable variations. The *structural concrete* f'_c lower limit is consistent with ACI 318.

Perimeter *connections* that transfer shear are critical and typically collect shear from the *concrete* through chemical bond or steel-headed stud anchor shear *resistance*. Chemical bond is critical at *diaphragm edge panels* and in the *diaphragm* field. The test curing time of seven days was chosen to provide a rational minimum time for undisturbed bonding.

E2.2 Test Calibration

Testing of a *single diaphragm system* involves limited tests and does not establish all parameter contributions (as variables) or *limit state* thresholds. Since *safety* and *resistance factors* associated with *connection* failures are typically more severe than those controlled by *panel out-of plane buckling*, it is possible to overstate the *available shear strength [factored resistance]* for a tested *configuration* that is controlled by panel buckling and not controlled by *connection* failure. The question is: When would *connection* failure have occurred if panel buckling had not occurred? This requires that the *diaphragm system safety* and *resistance factors* controlled by *connections* be applied to a tested *shear strength* controlled by *buckling*. As an example, a 9-foot span is tested and *panel out-of-plane buckling* controls. However, *connection-controlled* failure also might be imminent. If a lower *safety factor* is applied because *buckling* controls, this might provide a greater *available strength [factored resistance]* value than if an 8-foot span is tested and *connections* control failure, which might require a greater *safety factor*. This is consistent with *Standard* Section B1.1. However, if *structural analysis* using an established method indicates that *connection* failure is not imminent and that the *available strength [factored resistance]* controlled by *connections* will exceed the *available strength [factored resistance]* controlled by *buckling* and the *buckling* limit is reasonably confirmed by test, it should be acceptable to apply the *buckling safety* and *resistance factor* to the test results.

If the tested *configuration* falls within the acceptable limits of an existing system model, it is rational to accept the existing *safety* and *resistance factors* in lieu of the *factors* based on three to six tests as long as the test results fit the normal scatter of tests based on the existing model. In the absence of such data, the scatter discussed in the *Commentary* of Section E1.2.2 can be used for the models listed in *Commentary* Sections E1.2 and A4.

E2.3 Laboratory Testing Reports

Standard Section E2.3 adopts the test report requirements in AISI S907. See the *Commentary* on Section E1.2.3.

E2.4 Adjustment for Design

When an analytical method, such as Chapter D, that includes the impact of specified design parameters is not used in design but a *single diaphragm system* test is used for design, the *Standard* requires that the test results be adjusted for the specified design parameters.

E2.4.1 Diaphragms Without Structural Concrete Fill

Standard Section E2.4.1 extends the concept that design is based on the design *thickness* and the minimum specified mechanical properties of steel. *Standard* Section E2.1 requires that the specified design values be tested while recognizing the normal variance of ordered material properties. The calibration process uses the normal increase of material properties. Material factors in AISI S100 Table K2.1.1-1 already assume that F_y and F_u will be at least 10% greater than the specified minimum F_y and F_u . The reduction multiplier does not penalize tested values within the norm. The reduction is consistent with the design equations in AISI S100 that relate *connection resistance* to F_u rather than F_y . Tested properties should be relatively close to the design values so linear reductions are applied to most parameters to establish *nominal strength [resistance]*. The exception is concrete-filled *diaphragms* where the concrete fill shear contribution is historically proportional to the square root of f'_c . The contribution of *insulating concrete* is additive to the contribution of steel, both components are significant, and f'_c should be reasonably close to design values, even though limits are not set on the f'_c deviation. Adjustments for lightweight *insulating concrete* fill rationally address both contributions, but theoretically might not be precise since the adjustment assumes that the contribution of the *deck* equals the contribution of the *insulating concrete* fill (or one-half the total strength).

E2.4.2 Diaphragms With Structural Concrete Fill

Structural concrete often dominates *diaphragm* shear strength and *deck connections* contribute strength, to a lesser extent, in the field of *diaphragms*. The *concrete* over the top of *deck*, d_c , and *compressive strength*, f'_c , are most critical to *diaphragm* shear strength. Consequently, reductions are required for the *concrete* contribution without adjustments for other tested properties when the other properties are reasonably close to the specified properties. No limits are imposed on $f'_{c \text{ test}}$. The *Standard* imposes limits on *concrete* screed quality control and implicitly directs the testing engineer to aim at $d_{c \text{ test}}$ greater than d_c to avoid penalty. When a parameter is within the *Standard's* limits but less than the specified value, an increase in *nominal shear strength [resistance]* is not allowed for that parameter. The reduction functions are consistent with the *strength* contribution in *Standard* Section D4.2.

E2.5 Test Results Interpretation

Test frame size can limit tests to a single (*simple*)-span condition. *Commentary* Section E1.2 outlines existing analytical models that are acceptable in tests such as the analytical model presented in *Standard* Section D1. Such models indicate that with everything else being equal, single-span *nominal shear strength [resistance]* is greater than multiple-span strength. A 50

percent increase in the number of fasteners at *interior supports* can be determined as the maximum required increase to balance multiple-span and single-span *shear strengths* based on *Standard Section D1*. When *side-lap connection* contribution is significant, the required increase in *support connection* quantity can be negligible.

A weld kernel or the shank of a fastener at end-laps has the same tributary length as that of an *interior support connection*, while at service load, butt joint *connections* have the same tributary length as *connections* in simple spans. Near *nominal strength* redistribution occurs and each connection contributes as much as it can so tributary length has less meaning. To simplify field installation and to overcome quality control concerns at end-laps, *Standard Section E2.5* extends the *interior support* increase to *exterior supports* with lapped ends. At *exterior supports* (see Figure D1-1) where *panels* have butt joints or are at perimeter ends, design applications could require the same number of *connections* as the single-span test.

The design provisions in accordance with *Standard Section D1* indicate the theoretical difference in *resistance* between single- and multiple-span *diaphragms* and can, therefore, be used to determine the additional required number of *interior support connections* so the multiple-span *diaphragms* provide the same *nominal strength [resistance]* as the single-span *diaphragm* system. If the single-span test results reasonably confirm the single-span theoretical result, the designer might increase the number of *interior support connections* and apply the test results to multiple-span applications.

The required number of *support connections* depends on the number and type of *side-lap connections*. A detailed discussion is presented in Example 4 of the AISI Design Guide (2014). See Figure C-E2.5-1 for an illustration of how to fulfill an analysis requirement to increase fasteners at *interior supports* by approximately 50% to justify the use of the single-span tested strength.

The required location of additional fasteners at *interior supports* is consistent with *Standard Section D1* since those *support connections* furthest from the *panel center line* provide the greatest benefit in the determination of α_p^2 and S_n .

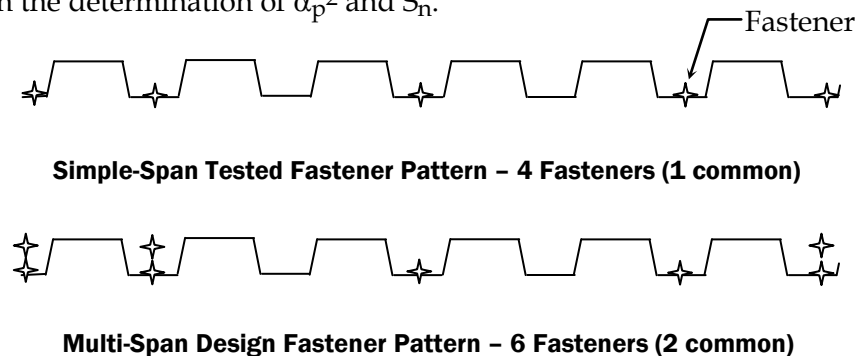

Figure C-E2.5-1 Fasteners Required in Multiple-Span Application Based on Single-Span Test of a Single Diaphragm System

APPENDIX 1: DETERMINATION OF FACTORS, D_n AND γ_c

1.1 General

1.1.1 Scope

The factors, D_n and γ_c are necessary to calculate the *stiffness*, G' .

1.1.2 Applicability

This appendix applies to perforated and non-perforated fluted *panels*. Warping, associated with D_n , is negligible in *cellular deck* and *diaphragms* with fill.

1.2 Determination of Warping Factor, D_n

For a given shear stress, more shear and warping displacements will occur in longer elements of a profile with open cross-section. Those impacts have been considered in the generalized *stiffness* equation presented in *Standard* Eq. D5.1.1-1 where the shear deformation impact is considered in the first term of the denominator and warping deformation impact is considered in warping factor, D_n .

Since end warping is restrained by *structural* or *insulating concrete* fill, D_n does not appear in *Standard* Eqs. D5.4.1-1 or D5.4.2-1. In *Standard* Eq. D5.3.1-1, *cellular deck* requires a modifier for material shear displacement due to *load* sharing between the bottom plate and top *deck*, and torsional restraint in profiles with closed cross-section makes D_n negligible. A condensed text is presented in *Commentary* Appendix 1 Section 1.4 and summarizes the development of D_n .

Perforations in any profile element reduce the shear and *flexural stiffness* of that element. A shear *stiffness* change impacts the shear displacement of the element (indicated by the first term in the denominator of *Standard* Eq. D5.1.1-1), while a *flexural stiffness* change (resisting transverse racking) impacts the profile warping factor, D_n , i.e., the second term in the denominator. *Standard* Section D5.1.1 allows calculation of these impacts by determining the equivalent lengths of an unperforated element for shear displacement and end warping respectively. These modified lengths are substituted in *Standard* Eq. D5.1.1-1. The warping adjustment is discussed in *Commentary* Appendix 1 Section 1-6.

Table C-1.1 presents dimensions and Table C-1.2 presents the warping parameter, D , for generic *deck* profiles. D_n is related to D as shown in *Standard* Eq. 1.4-1. D_n is dimensionless but D has units as shown in *Standard* Appendix 1 Section 1.4, so L must be in the same units as D . The *panel* manufacturers can use product-specific dimensions and *Standard* Appendix 1 Section 1.4 to determine D_n for other profiles.

Note in the Tables C-1.1 and C-1.2:

- WR = Wide rib and commonly called B *deck*
- IR = Intermediate rib and commonly called F *deck*
- NR = Narrow rib and commonly called A *deck*
- DR = Deep rib and commonly called N *deck*

Table C-1.1a
Profile Dimensions (Customary Units in.)

Type	D_d	w	d	2e	f	s
WR	1.47	1.53	6.00	1.56	3.56	8.19
IR	1.47	1.59	6.00	0.53	4.24	7.95
NR	1.47	1.51	6.00	0.36	4.99	8.36
DR	3.00	3.07	8.00	1.49	5.24	12.86

Note: Table C-1.1 column headers are shown in *Standard* Appendix 1, Figure 1.4-1, and *Standard* Section D2.1.

Table C-1.1b
Profile Dimensions (SI Units mm)

Type	D_d	w	d	2e	f	s
WR	37.3	39.0	152	39.7	90.5	208
IR	37.3	40.5	152	13.4	108	202
NR	37.3	38.3	152	9.10	127	212
DR	76.2	77.9	203	37.8	133	327

Table C-1.2
D Values

Roof Deck Type	t		Valley Spacing							
			Each		Alternate		Third		Fourth	
	in	mm	in	m	in	m	in	m	in	m
WR	0.0295	0.75	1237	31.40	10329	262.35	21247	539.65	33966	862.75
	0.0358	0.91	925	23.50	7726	196.25	15893	403.70	25407	645.35
	0.0474	1.20	607	15.40	5071	128.80	10432	264.95	16677	423.60
	0.0598	1.52	429	10.90	3579	90.90	7362	187.00	11769	298.95
IR	0.0295	0.75	2234	56.75	10336	262.55	20266	514.75	31880	809.75
	0.0358	0.91	1671	42.45	7731	196.35	15159	385.05	23846	605.70
	0.0474	1.20	1097	27.85	5075	128.90	9950	252.75	15652	397.55
	0.0598	1.52	774	19.65	3581	90.95	7022	178.35	11046	280.55
NR	0.0295	0.75	3802	96.55	13486	342.55	25599	650.20	39828	1011.65
	0.0358	0.91	2844	72.25	10087	256.20	19149	486.40	29791	756.70
	0.0474	1.20	1867	47.40	6621	168.15	12569	319.25	19555	496.70
	0.0598	1.52	1317	33.45	4672	118.65	8870	225.30	13800	350.50
DR	0.0295	0.75	7224	183.50						
	0.0358	0.91	5404	137.25						
	0.0474	1.20	3547	90.10						
	0.0598	1.52	2503	63.60						

Standard Section D2.1 and Appendix 1 Section 1.4 show the required units. Where those units are used and the method of Appendix 1 is applied, the SI value of D is mm. For convenience of size, D is converted to m in Table C-1.2. Some valley spacing in Table C-1.2 is not recommended for *serviceability* in roofs and exceeds industry standards, while other spacing physically is not possible because of product *pitch* and available cover widths. Typical roof fastener spacing is limited to each or alternate corrugations, with three being a maximum. Table C-1.2 values are included to illustrate that numbers can be determined and can be used as a computer program check. Fasteners spaced at every fourth corrugation are quite possible in non-composite *form decks*. Table C-1.2 does not limit *thickness*; other *thicknesses* are permitted.

1.3 Determination of Support Factor, γ_c

The support factors are based on tests and taken from SDI DDM01 (SDI, 1981).

1.4 Determination of Warping Factor Where Insulation Is Not Present Beneath the Panel

Commentary on Diaphragm Panel End Warping by Luttrell:

Open corrugated or fluted steel *panels* are produced with individual *panel* widths containing flutes as shown in *Standard* Figure 1.4-1. *Panels* may be several feet (m) long and installed over supports using fasteners through the *panel's* bottom flanges. Under in-plane shear *loading*, the connected *diaphragm* lower flanges receive direct *loads* from the frame while top elements are *loaded* by shears moving through supporting *webs*, *w*. The top flange typically is not connected to supports at *panel* ends and the section can roll over in torsion from the uneven *loading*. This allows the top flange at the *panel* end to move laterally, i.e., perpendicular to the *panel* span.

Diaphragm stiffness is defined as $G' = \frac{Sa}{\Delta}$

where:

S = specified average shear level,

a = system width, and

$\Delta = \Delta_S + \Delta_D + \Delta_C$.

In order, these deflection components are material shear displacement, shear relaxation from warping, and slip at fasteners.

The Δ_D expression was first developed prior to publishing the Steel Deck Institute *Diaphragm Design Manual*, First Ed., in 1981. This warping expression involves a fourth order differential equation and up to five interconnected horizontal *panel* elements acting as beams on elastic foundations. The materials in the successive groups of equations presented in *Standard* Appendix 1.4 represent the general warping solution. Specific warping D values from this solution are listed in Table C-1.2 for certain standard *deck* profiles.

Referring to *Standard* Appendix 1 Figure 1.4-1, *s* is the developed width per *pitch*, *d*. A unit length of the *panel* of *Standard* Appendix 1 Figure 1.4-1 is considered as a frame under horizontal unit *load* applications. For any pair of designated points, *i* and *j*, deflections can be established as δ_{ij} and read, for example, as "deflection at point 1 due to a unit *load* at point 2." Here, 2 represents a point at the right edge of the *f* element and 1, a point at middle of the lower flange, of width $2e$, to the right of the figure. For a single flute with a fastener at the bottom left and a roller support at the right, unit *loadings* lead to δ_{11} , δ_{12} , and δ_{22} as defined in *Standard*

Eq. 1.4-8 through Eq. 1.4-10.

The combined δ_{ij} terms can be used to describe spring constants that indicate the *resistance* of horizontal *panel* elements to lateral movement under *load*. With $n = 2$ marking the case of fasteners in alternate valleys, the top spring constants are in the form $K_{t2} = \kappa_{t2} (EI)$ for a *panel thickness*, t , where $EI = \frac{E(b)t^3}{12}$ and b is a unit length of *panel*, 1 in. or 1 mm as applicable.

Subscript, b_2 , marks a bottom flange condition where $n = 2$. This model leads to *Standard* Eq. 1.4-11 through Eq. 1.4-20.

The released end restraints lead to top displacements, δ_{tn} , and bottom displacements, δ_{bn} , where n is 1, 2, 3, or 4 for fasteners in each valley, every second valley, every third valley, or every fourth valley. These displacements are used to measure the energy associated with the transverse restraints. Combining forms for $n = 1, 2, 3, 4$ valley spacing, this model leads to *Standard* Eq. 1.4-21 through Eq. 1.4-30.

For applications where the *panel* has mixed end fastener conditions, U_1 of the total *panel* width has D_1 warping; U_2 of the width has D_2 warping; U_3 has D_3 warping; and U_4 has D_4 warping, the mixed warping effect D then is the weighted average in accordance with *Standard* Eq. 1.4-2.

For example, a 36 in. (915 mm)-wide *panel* with 6 in. (152 mm)-wide flutes (6 corrugations) has a leading edge fastener, with the next fastener being 6 in. (152 mm) (1 corrugation) from the edge; the next fastener is at 12 in. (305 mm) (2 corrugations) from the last one; and the far edge fastener 18" (457 mm) (3 corrugations) beyond the previous. In this example: $U_1 = 1$, $U_2 = 2$, $U_3 = 3$, $U_4 = 0$ and the sum $U_1 + U_2 + U_3 = 6$ or 6 corrugations per *panel* width. Then apply *Standard* Eq. 1.4-2:

$$D = \frac{6D_1 + 12D_2 + 18D_3}{36} = \frac{D_1 + 2D_2 + 3D_3}{6}$$

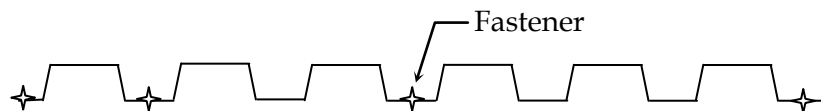

Figure C-1.4-1 Example to Determine D

The approach presented here is adaptable to a spreadsheet application from which warping D values may be easily established.

1.5 Determination of Warping Factor Where Insulation is Present Beneath the Panel

The method of *Standard* Appendix 1.5 is an approximation of *Standard* Appendix 1.4 and is based on a parametric study by Luttrell (MCA, 2001), which is published in *A Primer on Diaphragm Design* (MCA, 2004). There is relatively good agreement, particularly at $\psi = 2$ and 3. Some agreement accuracy is lost at $\psi = 4$ and this case is excluded. Fasteners at every fourth corrugation are rare but can occur in shallow product with relative small *pitch* such as concrete *form deck*. Even here, concrete fill is normally installed and the end warping concern only applies without fill.

The greatest difference occurs in the D_1 term (*Standard* Eq. 1.4-3/L vs. *Standard* Eq. 1.5-2),

but D_1 is normally small and not dominant in the calculation of G' . There are three terms in the denominator of G' and as D_n decreases, the impact on G' is less.

The parametric study did not include perforated *panels*. When perforated *panels* are present, use *Standard* Appendix 1.6. However, when the manufacturer says the impact of perforations is negligible, it is reasonable to use *Standard* Appendix 1.5.

1.6 Determination of Warping Factor for Perforated Deck

Developed by Luttrell, SDI (2011) presents a method to determine the impact of perforations on shear displacement and end warping. This method was adopted in the *Standard* to calculate G' .

The reduced stiffness of perforated elements can affect the three components in the denominator of *Standard* Eq. D5.1.1-1 and the two components in *Standard* Eq. D5.3.1-1. The profile parameters, D_d and d , in *Standard* Figure 1.4-1 are not modified in the *Standard's* equations. The modified values of e_p , f_p , w_p are not used in *Standard* Eq. 1.4-12 through Eq. 1.4-34. The equations assume that the perforation pattern, and thus k , will be a constant in all elements of the profile.

p_o can be obtained from the *panel* manufacturer or by using tables published by the Industrial Perforators Association (IPA) for the profile's perforation pattern. For the common 60 degree staggered pattern:

$$p_o = 0.9069 \frac{d_p^2}{c_p^2} \quad (\text{C-1.6-1})$$

where

d_p = Perforation hole diameter

c_p = Hole center-to-center spacing

An example is: $d_p = 0.188$ in. (4.78 mm) and $c_p = 0.375$ in. (9.53 mm) leading to $p_o = 0.228$ and $k = 0.524$. The IPA test-based limits on p_o are imposed in the *Standard*. Common products use p_o close to 0.1. *Rational engineering* suggests that for p_o less than 0.2:

$$k = 1 - 2.175p_o \quad (\text{C-1.6-2})$$

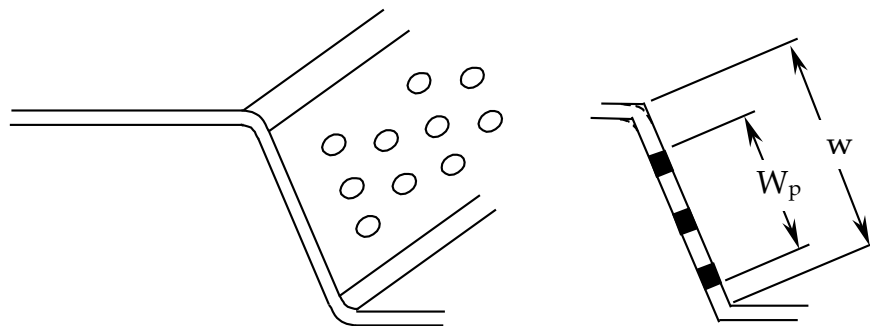

Figure C-1.6-1 Example of Perforated Deck With Holes Only in Web

For the *web* shown in Figure C-1.6-1:

$$A_w = \frac{W_p}{w} \quad (\text{C-1.6-3})$$

where

A_w = Ratio to perforated width (in *web*) to the full element (*web*) width.

See *Standard* Eq. 1.6-4. ($i = w$ at A_i)

W_p = Out-to-out perforation band width in *web*

w = Point-of-intercept to point-of-intercept *web* width

Similarly in *Standard* Appendix 1.6:

$$A_e = \frac{E_p}{2e} \quad (i = e \text{ at } A_i) \quad \& \quad A_f = \frac{F_p}{f} \quad (i = f \text{ at } A_i)$$

The impact of perforations on the other components in the denominator of *Standard* Eq. D5.1.1-1 is discussed in *Commentary* Section D5.1.2.

The *Standard's* method to calculate the impact of perforations on D_n and G' is consistent with SDI (2011). If perforations are not at fastener locations and only located in the bottom plates of *cellular deck*, the effect of perforations on G' is negligible. In this case, C (*Standard* Eq. D5.1.1-2) and s (in *Standard* Eq. D5.3.1-2) are not affected. Perforations that are only in the *webs* of *deck* (non-cellular) can have negligible effect on D_n and G' where p_o and W_p are small.

APPENDIX 2: STRENGTH AT PERIMETER LOAD DELIVERY POINT

The *required load* must be transmitted to a *diaphragm* to develop the *available shear strength* [*factored resistance*]. The *Standard* appendix considers the development of additional shear in *connections* at a *load* delivery point where the perimeter edge is perpendicular to the *panel* length. Sometimes drag struts are provided to transmit *load*, and this is analogous to stiffeners below concentrated *loads* in plate girders. When the perimeter supports along the *diaphragm* length are not sufficiently stiff and struts are not provided to relieve bending in the supports, compression can be developed in the *panel* to transmit the *load* and develop shear.

The design should consider the combined bending and axial *stress* interaction in the *panel*. The *Standard* appendix provides a rational design method based on AISI S100 and considers both axial compression and tension. The compression or tension consideration is analogous to checking local *bearing* or pull on the *web* of a beam or plate girder due to a large concentrated *load*. This sometimes requires transverse stiffeners in beams. The condition in *diaphragms* sometimes requires extra perimeter fasteners and requires a check of the *panel* as a column strut and a consideration of eccentric end moment in the *panel*.

The definition of limited weak axis bending is not precise and requires judgment. Simplistically, use the theoretical deflection of the support at the upper bound shear transfer, w_a (or per *connection*, w_a/N), and the *connection flexibility* response as a first iteration to estimate the part transmitted to the *panel* in compression. The *panel* normally has sufficient capacity to transfer *load*, and additional fasteners at the perimeter do not significantly impact the overall installation. If there is doubt, check the effect by neglecting any transverse *load* transfer to the spandrel beam in bending and use *Standard* Eq. 2.2-1 as applicable.

Obtain the required profile properties from the manufacturer. For common profiles, visit SDI DDM03 (2004) Appendix V for a reasonable approximation of I_{xg} and *Commentary* Table C-1.1 for s , as defined in *Standard* Eq. D2.1-2, so that A_g can readily be determined. Since manufacturers commonly publish I_x to calculate deflection based on the effective widths at the *stress* caused by *service loads*, many designers substitute this value for I_{xg} .

REFERENCES

- American Iron and Steel Institute (2016), AISI S100-16, *North American Specification for the Design of Cold-Formed Steel Structural Members*, 2016.
- American Iron and Steel Institute (2014), AISI Design Guide, *Design Examples for the Design of Profiled Steel Diaphragm Panels Based on AISI S310-13*, 2014.
- American Iron and Steel Institute (1997), CF97-1, *A Guide for Designing with Standing Seam Roof Panels*, 1997.
- American Society of Civil Engineering (2010), ASCE 7 Including Supplement No. 1, *Minimum Design Loads for Buildings and Other Structures*, 2010.
- Applied Technology Council (2011), FEMA P-795, *Quantification of Building Seismic Performance Factors: Component Equivalency Methodology*, 2011.
- ASTM International (2005), ASTM C39/C39M-05e1, *Standard Test Method for Compressive Strength of Cylindrical Concrete Specimens*, 2005.
- ASTM International (1999), ASTM C495-99a, *Standard Test Methods for Compressive Strength of Lightweight Insulation Concrete*, 1999.
- ASTM International (2011), ASTM C869/C869M-11, *Standard Specification for Foaming Agents Used in Making Preformed Foam for Cellular Concrete*, 2011
- ASTM International (2010), ASTM C1513-10, *Standard Specification for Steel Tapping Screws for Cold-Formed Steel Framing Connections*, 2010
- ASTM International (2011), ASTM E455, *Standard Method for Load Testing of Framed Floor, Roof and Wall Diaphragm Construction for Buildings*, 2011.
- Bagwell, J.M. and W.S. Easterling (2008), "Deep Deck and Cellular Deck Diaphragm Strength and Stiffness Evaluation," Report No. CE/VPI-ST-08/03, Virginia Polytechnic Institute and State University, 2008.
- Bulleit, W. M., (2006), "Reliability of Wood Connections Designed Using LRFD from NDS-2005," *Proceedings of the World Conference on Timber Engineering*, Portland, OR, August 6-10, 2006.
- Department of Army (1982), *Seismic Design for Buildings*, U.S. Army Technical Manual 5-809-10, Washington, DC, 1982.
- Easley, J. T. (1975), "Strength and Stiffness of Corrugated Metal Shear Diaphragms," *Journal of the Structural Division*, ASCE, Volume 101, July 1975.
- Easley, J. T. (1977), "Strength and Stiffness of Corrugated Metal Shear Diaphragms," *Journal of the Structural Division*, ASCE, Volume 103, January 1977.
- Easterling, W.S. and M. L. Porter (1988), "Behavior, Analysis, and Design of Steel-Deck-Reinforced Concrete Diaphragms," College of Engineering, Iowa State University, March 1988.
- Easterling, W.S. and M. L. Porter (1994), "Steel-Deck Reinforced Concrete Diaphragms, I," *Journal of Structural Engineering*, Vol 120, No. 2, February 1994.
- Easterling, W.S. and M. L. Porter (1994), "Steel-Deck Reinforced Concrete Diaphragms, II," *Journal of Structural Engineering*, Vol 120, No. 2, February 1994.
- Ellifritt, D.S. (1970), "The Strength and Stiffness of Steel Deck Subjected to In-Plane Loading," Dissertation, West Virginia University, 1970.

- Francka, R. M. and R.A. Laboube (2009), "Screw Connections Subject to Tension Pull-Out and Shear Forces," Research Report, Missouri University of Science & Technology, December 2009.
- Guenfoud, N., R. Tremblay and C.A. Rogers (2010), "Arc-Spot Welds for Multi-Overlap Roof Deck Panels," *Proceedings of the Twentieth International Specialty Conference on Cold Formed Steel Structures*, Missouri University of Science & Technology, November 2010.
- Lease, A. and W. S. Easterling (2006), "Insulation Impact on Shear Strength of Screw Connections and Shear Strength of Diaphragms," Report No. CE/VPI-ST-06/01, Virginia Polytechnic Institute and State University, 2006.
- Luttrell, L.D. (1967), "Strength and Behavior of Light-Gage Steel Shear Diaphragms," *Cornell Engineering Research Bulletin*, 1967.
- Luttrell, L.D. (1999a), "Metal Construction Association Diaphragm Test Program Final Report," West Virginia University, April 12, 1999.
- Luttrell, L.D. (1999b), "Metal Construction Association Diaphragm Test Program, Part I, Aluminum Diaphragms & Part II, Fastener Performance," West Virginia University, March 26, 1999.
- Luttrell, L.D. (2001), *MCA Diaphragm Program and Design Reviews*, Metal Construction Association, June 12, 2001.
- Luttrell, L.D. (2002), *A Primer on Diaphragm Design for Metal Construction Association, Commentary on Section 7*, October 30, 2002.
- Luttrell, L.D. and H.T. Huang (1981), "Steel Deck Diaphragm Studies," West Virginia University, Civil Engineering Studies, January 1981.
- Metal Construction Association (2004), *A Primer on Diaphragm Design*, First Edition, Metal Construction Association, Glenview IL, 2004.
- National Roof Deck Contractors Association, Frequently Asked Questions, www.nrdca.org, 2012
- NAVFAC (1982), *Seismic Design For Buildings; Technical Manual TM 5-809-10/NAVFAC P-355/AFM 88-3*, (Tri-Service Manual), Departments of the Army, the Navy, and the Air Force, October 1982.
- Nowak, A. and M. Szerszen (2003), "Calibration of Design Code for Buildings (ACI 318) Part 1, Statistical Models for Resistance," *ACI Structural Journal*, May-June 2003.
- Nunna, R. and C. W. Pinkham (2012), "Top Arc Seam Welds (Arc Seam Weld on Standing Seam Hem) Shear Strength [Resistance] and Flexibility for Sheet-to-Sheet Connections," S. B. Barnes Associates, Report No. 11-01, February 17, 2012.
- Nunna, R. (2011), "Buckling of Profiled Steel Diaphragms," S. B. Barnes Associates, Report No. 11-03, October 21, 2011.
- Petersons, N. (1968), "Should Standard Cube Test Specimens Be Replaced by Test Specimens Taken from Structures," *Materiaux et Constructions, Reunion Internationale des Laboratoires d'Essais et de Recherches sur les Materiaux et les Constructions*, Paris, France, Vol. 1, No. 5, pp. 425-435, 1968.
- Rosowsky, D; D. S. Gromala and P. Line (2005), "Reliability-Based Code Calibration for Design of Wood Members Using Load and Resistance Factor Design," *Journal Of Structural Engineering*, ASCE, February 2005.

- Snow, G. L. and W. S. Easterling (2008), "Strength of Arc Spot Welds Made in Single and Multiple Steel Sheets," *Proceedings of the Nineteenth International Specialty Conference on Cold-Formed Steel Structures*, Missouri University of Science & Technology, October 2008.
- Steel Deck Institute (1981), *Diaphragm Design Manual*, First Edition, Steel Deck Institute, January 1981.
- Steel Deck Institute (1987), *Steel Deck Institute Diaphragm Design Manual*, Second Edition, Steel Deck Institute, 1987.
- Steel Deck Institute (2004), *Diaphragm Design Manual*, Third Edition, Steel Deck Institute, 2004.
- Steel Deck Institute (2006), *Manual of Construction with Steel Deck*, Steel Deck Institute, 2006.
- Steel Deck Institute (2011), *Perforated Metal Deck Diaphragm Design*, Steel Deck Institute, March 25, 2011.
- Steel Deck Institute (2011), *Perforated Metal Deck Design with Commentary*, Steel Deck Institute, November 18, 2011.
- Steel Deck Institute (2011), ANSI/SDI QA/QC-2011, *Standard for Quality Control and Quality Assurance for Installation of Steel Deck*, Steel Deck Institute, 2011.
- Steel Deck Institute (2014), *SDI Code of Standard Practice*, Steel Deck Institute, July 2014.
- Steel Deck Institute (2013), *Deeper Steel Deck and Cellular Diaphragms, Supplement to 2005 Edition*, Steel Deck Institute, 2013.
- Stirnemann, L.K. and R.A. LaBoube (2007), "Behavior of Arc Spot Weld Connections Subjected to Combined Shear and Tension Forces," Research Report, University of Missouri-Rolla, 2007.
- Stojadinovic, B. and S. Tipping (2008), "Structural Testing of Corrugated Sheet Steel Shear Walls," University of California at Berkeley, Charles Pankow Foundation, 2008.
- Tabsh, S. (1997), "Safety of Reinforced Concrete Members Designed Following ACI 318 Building Code," *Engineering Structures*, Elsevier Science Ltd, Vol 19, No 10, pp. 843-850, 1997.
- Yu, W. W. and R. A. LaBoube (2010), *Cold-Formed Steel Design*, Fourth Edition, John Wiley & Sons, New York, NY, 2010.
- Zwick, K., and R. A. LaBoube (2006), "Self-Drilling Screw Connections Subjected to Combined Shear and Tension," Department of Civil, Architectural, and Environmental Engineering, University of Missouri-Rolla, 2006.



**American
Iron and Steel
Institute**

25 Massachusetts Avenue NW
Suite 800
Washington, DC 20001
www.steel.org





**American
Iron and Steel
Institute**

25 Massachusetts Avenue NW
Suite 800
Washington, DC 20001
www.steel.org

