

01 Dec 2015

North American Standard for Seismic Design of Cold-Formed Steel Structural Systems, 2015 Edition with Supplement 1

American Iron and Steel Institute

Follow this and additional works at: <https://scholarsmine.mst.edu/ccfss-aisi-spec>



Part of the [Structural Engineering Commons](#)

Recommended Citation

American Iron and Steel Institute, "North American Standard for Seismic Design of Cold-Formed Steel Structural Systems, 2015 Edition with Supplement 1" (2015). *AISI-Specifications for the Design of Cold-Formed Steel Structural Members*. 196.

<https://scholarsmine.mst.edu/ccfss-aisi-spec/196>

This Technical Report is brought to you for free and open access by Scholars' Mine. It has been accepted for inclusion in AISI-Specifications for the Design of Cold-Formed Steel Structural Members by an authorized administrator of Scholars' Mine. This work is protected by U. S. Copyright Law. Unauthorized use including reproduction for redistribution requires the permission of the copyright holder. For more information, please contact scholarsmine@mst.edu.



AISI S400-15 w/S1-16



AISI STANDARD

**North American Standard
for Seismic Design of
Cold-Formed Steel
Structural Systems**

2015 Edition With Supplement 1



AISI S400-15 w/S1-16



AISI STANDARD

North American Standard for Seismic Design of Cold-Formed Steel Structural Systems

2015 Edition With Supplement 1

DISCLAIMER

The material contained herein has been developed by the American Iron and Steel Institute (AISI) Committee on Framing Standards. The Committee has made a diligent effort to present accurate, reliable, and useful information on seismic design for cold-formed steel structures. The Committee acknowledges and is grateful for the contributions of the numerous researchers, engineers, and others who have contributed to the body of knowledge on the subject. Specific references are included in the *Commentary on the Standard*.

With anticipated improvements in understanding of the behavior of cold-formed steel and the continuing development of new technology, this material will become dated. It is anticipated that AISI will publish updates of this material as new information becomes available, but this cannot be guaranteed.

The materials set forth herein are for general purposes only. They are not a substitute for competent professional advice. Application of this information to a specific project should be reviewed by a registered professional engineer. Indeed, in many jurisdictions, such a review is required by law. Anyone making use of the information set forth herein does so at their own risk and assumes any and all liability arising therefrom.

First Printing – December 2015
Second Printing – September 2016

Copyright American Iron and Steel Institute 2015

PREFACE

The American Iron and Steel Institute (AISI) Committee on Framing Standards has developed this first edition of the *North American Standard for Seismic Design of Cold-Formed Steel Structural Systems* (hereinafter referred to as this *Standard* in general) in 2015. This *Standard* is intended to address the design and construction of cold-formed steel structural members and connections used in the seismic force-resisting systems in buildings and other structures. In this first edition, the material represents a merging of AISI S110, *Standard for Seismic Design of Cold-Formed Steel Structural Systems – Special Bolted Moment Frames, 2007 Edition with Supplement No. 1-09*, and the seismic portions of AISI S213, *North American Standard for Cold-Formed Steel Framing – Lateral Design, 2007 Edition with Supplement No. 1-09*. In addition, many of the seismic design requirements stipulated in this *Standard* are drawn from ANSI/AISC 341-10, *Seismic Provisions for Structural Steel Buildings*, developed by the American Institute of Steel Construction (AISC). The application of this *Standard* should be in conjunction with AISI S100, *North American Specification for the Design of Cold-Formed Steel Structural Members* (hereinafter referred to as AISI S100), and AISI S240, *North American Standard for Cold-Formed Steel Framing* (hereinafter referred to as AISI S240).

The Lateral Design Subcommittee of the AISI Committee on Framing Standards is responsible for the ongoing development of this *Standard*. The AISI Committee on Framing Standards gives the final approval of this document through an ANSI-accredited balloting process. The membership of these committees follows this Preface.

The Committee acknowledges and is grateful to the numerous engineers, researchers, producers and others who have contributed to the body of knowledge on these subjects. AISI further acknowledges the permission of the American Institute of Steel Construction for adopting many provisions from its *Seismic Provisions for Structural Steel Buildings*.

In this first edition of AISI S400, special recognition is extended to Hank Martin, Sr. who served as AISI's West Coast Regional Director of Construction Codes and Standards from 1982 to 2006. Hank was pivotal in the initial adoption of cold-formed steel lateral design into the model building codes. His vision for the industry led to the establishment of the AISI Committee on Framing Standards in 1998, the development of AISI S213 in 2004, and, eventually, to the publication of AISI S110 in 2009.

Building on the work initiated by Hank, the AISI S400 Working Group spent the past two years developing the new combined seismic standard, AISI S400. The committee would like to thank the members of the AISI S400 Working Group, which includes Rob Madsen, Ben Schafer, Colin Rogers, and J.R. Mujagic, for their herculean job. Additionally, the committee would like to thank Shahab Torabian, Randy Shackelford and Roger LaBoube for their contributions to the document.

In the second printing of this standard, Supplement 1 to AISI S400-15 is incorporated.

American Iron and Steel Institute
November 2015
Updated September 2016

This Page is Intentionally Left Blank.

COMMITTEES THAT APPROVE AISI S400-15

AISI COMMITTEE ON FRAMING STANDARDS (2015)

Rick Haws, <i>Chairman</i>	Nucor Corporation
Steve Fox, <i>Vice Chairman</i>	Canadian Sheet Steel Building Institute
Helen Chen, <i>Secretary</i>	American Iron and Steel Institute
Don Allen	Super Stud Building Products
Bill Babich	Alpine TrusSteel
Brad Cameron	Cameron & Associates Engineering, LLC
Randy Daudet	Simpson Strong-Tie
Jim DesLaurier	Certified Steel Stud Association
Scott Douglas	National Council of Structural Engineers Associations
Nader Elhajj	FrameCAD Solutions
Pat Ford	Steel Framing Industry Association
Jeff Klaiman	ADTEK Engineers
Roger LaBoube	Wei-Wen Yu Center for Cold-Formed Steel Structures
Rob Madsen	Supreme Steel Framing System Association
John Matsen	Matsen Ford Design Associates
Cris Moen	Virginia Polytechnic Institute and State University
Kenneth Pagano	Scosta Corporation
Mike Pellock	Aegis Metal Framing
Nabil Rahman	The Steel Network, Inc.
Greg Ralph	ClarkDietrich Building Systems
Ben Schafer	The Johns Hopkins University
Fernando Sesma	California Expanded Metal Products
Sutton Stephens	Pacific Northwest Engineering, Inc.
Steven Walker	Light Gauge Steel Engineering Group, Inc.
Robert Wessel	Gypsum Association
Lei Xu	University of Waterloo
Cheng Yu	University of North Texas
Rahim Zadeh	Steel Stud Manufacturers Association
Ron Ziemian	Structural Stability Research Council

LATERAL DESIGN SUBCOMMITTEE (2015)

Rob Madsen, <i>Chairman</i>	Supreme Steel Framing System Association
Helen Chen, <i>Secretary</i>	American Iron and Steel Institute
Don Allen	Super Stud Building Products
Brad Cameron	Cameron & Associates Engineering, LLC
Nader Elhajj	FrameCAD Solutions
Bill Gould	Hilti, Inc.
Perry Green	Bechtel Power Corporation
Rick Haws	Nucor Corporation
Roger LaBoube	Wei-Wen Yu Center for Cold-Formed Steel Structures
Stephen Linch	Telling Industries
John Matsen	Matsen Ford Design Associates, Inc.
Cris Moen	Virginia Polytechnic Institute and State University
J.R. Mujagic	Uzun & Case Engineers LLC
Ashwin Mupparapu	Structuneering Inc.
Robert Paullus	National Council of Structural Engineers Associations
Nabil Rahman	The Steel Network, Inc.
Greg Ralph	ClarkDietrich Building Systems
Colin Rogers	McGill University
Ben Schafer	The Johns Hopkins University
Reynaud Serrette	Santa Clara University
Fernando Sesma	California Expanded Metal Products
Randy Shackelford	Simpson Strong-Tie
K.S. Sivakumaran	McMaster University
Chia-Ming Uang	University of California, San Diego
Lei Xu	University of Waterloo
Henry Yektai	Paco Steel Engineering
Cheng Yu	University of North Texas
Rahim Zadeh	Steel Stud Manufacturers Association

COMMITTEES THAT APPROVE SUPPLEMENT 1 TO AISI S400-15

AISI COMMITTEE ON FRAMING STANDARDS (2016)

Roger LaBoube, <i>Chairman</i>	Wei-Wen Yu Center for Cold-Formed Steel Structures
Steve Fox, <i>Vice Chairman</i>	Canadian Sheet Steel Building Institute
Helen Chen, <i>Secretary</i>	American Iron and Steel Institute
Don Allen	Super Stud Building Products
Bill Babich	Alpine TrusSteel
Brad Cameron	Cameron & Associates Engineering, LLC
Randy Daudet	Simpson Strong-Tie
Jim DesLaurier	Certified Steel Stud Association
Nader Elhajj	FrameCAD Solutions
Pat Ford	Steel Framing Industry Association
Rick Haws	Nucor Buildings Group
Danielle Jacobs	National Council of Structural Engineers Associations
Jeff Klaiman	ADTEK Engineers
Rob Madsen	Supreme Steel Framing System Association
Cris Moen	Virginia Polytechnic Institute and State University
J. R. Mujagic	Consulting Structural Engineer
Kenneth Pagano	Scosta Corporation
Mike Pellock	Aegis Metal Framing
Nabil Rahman	The Steel Network, Inc.
Greg Ralph	ClarkDietrich Building Systems
Ben Schafer	The Johns Hopkins University
Michael Schmeida	Gypsum Association
Fernando Sesma	California Expanded Metal Products
Sutton Stephens	Pacific Northwest Engineering, Inc.
Brandon Wahl	360 Engineering Group
Steven Walker	Light Gauge Steel Engineering Group, Inc.
Robert Warr	Frameworks Engineering, LLC
Lei Xu	University of Waterloo
Cheng Yu	University of North Texas
Rahim Zadeh	Steel Stud Manufacturers Association
Ron Ziemian	Structural Stability Research Council

LATERAL DESIGN SUBCOMMITTEE (2016)

Rob Madsen, <i>Chairman</i>	Supreme Steel Framing System Association
Helen Chen, <i>Secretary</i>	American Iron and Steel Institute
Don Allen	Super Stud Building Products
Patrick Bodwell	Verco Decking, Inc.
Jim DesLaurier	Certified Steel Stud Association
Nader Elhajj	FrameCAD Solutions
Brian Gerber	IAPMO Uniform Evaluation Service
Bill Gould	ICC-ES
Perry Green	Bechtel Power Corporation
Rick Haws	Nucor Buildings Group
Danielle Jacobs	National Council of Structural Engineers Associations
Roger LaBoube	Wei-Wen Yu Center for Cold-Formed Steel Structures
Cris Moen	Virginia Polytechnic Institute and State University
J.R. Mujagic	Structural Engineering Consultant
Ashwin Mupparapu	Structuneering, Inc.
Nabil Rahman	The Steel Network, Inc.
Greg Ralph	ClarkDietrich Building Systems
Colin Rogers	McGill University
Atsushi Sato	Nagoya Institute of Technology
Ben Schafer	The Johns Hopkins University
Walter Schultz	Nucor Vulcraft
Reynaud Serrette	Santa Clara University
Randy Shackelford	Simpson Strong-Tie
K.S. Sivakumaran	McMaster University
Matthew Speicher	NIST Engineering Laboratory
Tom Sputo	Steel Deck Institute
Shahabeddin Torabian	Cold-Formed Steel Research Consortium
Chia-Ming Uang	University of California, San Diego
Steve Walker	Light Gauge Steel Engineering Group, Inc.
Robert Warr	Frameworks Engineering, LLC
Lei Xu	University of Waterloo
Cheng Yu	University of North Texas
Rahim Zadeh	Steel Stud Manufacturers Association
Bill Zhang	Kansas State University

SYMBOLS

Symbol	Definition	Section
A_c	Gross cross-sectional area of <i>chord member</i> , in square in. (mm ²)	E1.4.1.4, E2.4.1.4
A_g	Gross area of the flat <i>strap</i>	E3.3.1, E3.3.3, E3.4.1
A_n	Net area of the flat <i>strap</i>	E3.4.1
a	Bolt spacing	E4.3.3
a	Wall aspect ratio	E2.3.1.1.1
b	Length of the <i>shear wall</i> , in in. (mm)	E1.4.1.4, E2.4.1.4
b	Bolt spacing	E4.3.3
C	Boundary <i>chord</i> force (tension/compression) (lb, kN)	E1.4.2.2, E2.4.2.2.2
C_a	Shear resistance adjustment factor	E1.3.1.2, E1.4.2.2, E1.4.2.2.2, E2.3.1.2, E2.4.2.2.1, E2.4.2.2.2
$C_B, C_{B,0}$	Coefficients for determining bearing strength and deformation	E4.3.3
C_d	Deflection amplification factor	B1.1
C_{DB}	Bearing deformation adjustment factor	
C_{DS}, C_S	Coefficients for determining slip strength and deformation	E4.3.3
c	Bolt spacing	E4.3.3
d	Bolt diameter	E4.3.3
E	Modulus of elasticity of steel, 29,500 ksi (203,000 MPa)	E1.4.1.4, E2.4.1.4, E4.4.3
E_{mh}	Effect of horizontal seismic forces including overstrength	E4.3.1
E_h	Horizontal seismic <i>load effect</i>	E4.3.1
F_a	Acceleration-based site coefficient, as defined in NBCC [Canada]	
F_y	<i>Specified minimum yield stress</i>	A3.2.1, A3.2.3, E4.3, E4.4.3
F_y	Yield stress of steel sheet sheathing	E2.3.1.1.1
F_y	Yield stress of the flat <i>strap</i>	E3.3.1, E3.3.3
F_{ya}	Yield stress due to cold work of forming	A3.2.3

SYMBOLS

Symbol	Definition	Section
F_u	<i>Specified minimum tensile strength</i>	A3.2.2, E4.3
F_u	Tensile strength of connected component	E4.3.3
F_{uf}	Minimum tensile strength of framing materials	E2.3.1.1.1
F_{ush}	Tensile strength of steel sheet sheathing	E2.3.1.1.1
G	Shear modulus of sheathing material, in lb/ in. ² (MPa)	E1.4.1.4, E2.4.1.4
h	Height of the <i>shear wall</i> , ft (m)	E1.3.1.1, E1.3.1.2.1, E1.4.1.4, E1.4.2.2.2, E2.3.1.1, E2.3.1.1.1, E2.3.1.2.2, E.2.4.1.4, E2.4.2.2.2, E3.3.1, E5.3.1.1, E6.3.1.1, E2.3.1.1.1
h	Height of <i>shear wall</i> segment	E1.4.2
h	Height from column base to center line of beam	E4.3.3
h_{os}	Hole oversize	E4.3.3
h_p	Height of <i>wall pier</i>	E1.3.1.1.1, E2.3.1.1.2
K	Elastic lateral stiffness of the frame line	E4.3.3
k	Slip coefficient	E4.3.3
L	<i>Diaphragm</i> resistance length, in ft (m)	F2.4.1
ΣL_i	Sum of lengths of <i>Type II shear wall segments</i> , ft (m)	E1.3.1.2, E1.3.1.2.1, E1.4.2.2, E1.4.2.2.2, E2.3.1.2, E2.3.1.2.1, E2.4.2.2.1, E2.4.2.2.2
M_e	Expected moment at a bolt group	E4.3.3
M_{no}	Nominal flexural strength determined in accordance with Section C3.1.1(b) of AISI S100	A3.2.3
M_{bp}	Required moment of a bolt bearing plate	
M_y	<i>Nominal flexural yield strength [resistance]</i>	A3.2.3
N	Number of channels in a beam	E4.3.3
n	Number of columns in a frame line	E4.3.3
P_n	Nominal shear strength [resistance] of	E2.3.1.1.1

SYMBOLS

Symbol	Definition	Section
	screw connections within the effective strip width, W_e , on the steel sheet sheathing	
R	<i>Seismic response modification coefficient</i>	A1.2.3, B1.1, E1.1.1, E2.2.2, E3.2.2, E4.2.2, E6.2.2, F2.2.1, F2.5
R_{BS}	Relative bearing strength	
R_{cf}	Factor considering strength increase due to cold work of forming	A3.2.3, E4.3
R_n	<i>Nominal strength</i>	B31, B3.2
R_0	Smallest value of dtR_tF_u of connected components	E4.3.3
R_d, R_o	<i>Seismic force modification factors</i>	A1.2.3, B1.1, B3.4, E1.2.2, E2.2.2, E2.4.1.3, E2.4.2.2.1, E3.2.2, E3.4.3, E5.4.1.2, E5.4.1.3, E7.2.2, 1.2
R_{re}	Factor considering inelastic bending reserve capacity	A3.2.3, E4.3
R_t	Ratio of expected tensile strength and <i>specified minimum tensile strength</i>	A3.2.2, E3.4.1, E4.3, E4.3.3
R_y	Ratio of expected yield stress to <i>specified minimum yield stress</i>	A3.2.1, A3.2.3, E3.3.3, E3.4.1, E4.3
S_e	Effective section modulus at yield stress, F_y	
S_f	Full unreduced section modulus at yield stress, F_y	A3.2.3
s	Maximum fastener spacing at panel edges, in in. (mm)	E1.4.1.4, E2.4.1.4
s	Screw spacing on the panel edges	E2.3.1.1.1
T	Snug-tightened bolt tension	E4.3.3
T_n	<i>Nominal strength [resistance] of the strap braced wall in yielding</i>	E3.3.1
T_S	S_{D1}/S_{DS} in accordance with applicable building code	
T_{sh}	Design thickness of steel sheet sheathing	E2.3.1.1.1
T_f	Minimum design thicknesses of framing members	E2.3.1.1.1
t	Thickness of the connected component	E4.3.3
t	Design thickness of steel sheet sheathing	E2.3.1.1.1
t_p	Thickness of bearing plate	E4.3.1.2
$t_{sheathing}$	Nominal panel thickness, in in. (mm)	E1.4.1.4, E2.4.1.4
t_{stud}	Stud <i>designation thickness</i> , in in. (mm)	E1.4.1.4, E2.4.1.4
t_w	Thickness of beam web	E4.3.1.2

SYMBOLS

Symbol	Definition	Section
V	Shear force	E1.4.2.2.1, E1.4.2.2.2, E2.4.2.2.1, E2.4.2.2.2
V	Total lateral <i>load</i> applied to the <i>shear wall</i> , in lb (N)	E1.4.1.4, E2.4.1.4
V_B	Connection bearing component of column shear corresponding to the displacement, Δ	E4.3.3
$V_{B,max}$	Column shear producing the bearing strength of a bolt group	E4.3.3
V_{bp}	<i>Required shear strength</i> of bolt bearing plates	E4.3.1.2
V_e	Expected strength of the bolted <i>connection</i>	E4.3.1.2, E4.3.3
V_n	<i>Nominal strength [resistance]</i> for shear	E1.3.1.1, E1.3.1.2, E1.3.2, E1.4.2, E2.3.1.1, E2.3.1.1.1, E2.3.1.2, E2.3.2, E2.3.3, E3.3.1, E3.3.2, E5.3.1.1, E5.3.2, E5.3.3, E6.3.1.1, E6.3.2, F1.4.2, F2.4.1, F2.4.2
V_S	Column shear corresponding to the slip strength of the bolt group	E4.3.3
v	Shear force per unit length	E1.4.2.2, E2.4.2.2.1
v	Shear demand, in lb/ in. (N/mm)	E1.4.1.4, E2.4.1.4
v_n	<i>Nominal shear strength [resistance]</i> per unit length	E1.3.1.1, E1.3.1.2, E2.3.1.1, E2.3.1.2, E5.3.1.1, E6.3.1.1, F2.4.1
w	Length of the <i>shear wall</i> , ft (m)	E1.3.1.1, E2.3.1.1, E2.3.1.1.1, E3.3.1, E5.3.1.1, E6.3.1.1
w	Length of <i>shear wall</i> segment	E1.4.2
w_e	Effective width	E2.3.1.1.1
w_p	Length of <i>wall pier</i>	E1.3.1.1.1, E2.3.1.1.2
Δ	<i>Design story drift</i>	E4.3.3, E4.4.1
Δ_B	Component of <i>design story drift</i> causing bearing deformation in a bolt group	E4.3.3
$\Delta_{B,max}$	Component of <i>design story drift</i> corresponding to the deformation of the bolt group at maximum bearing strength	E4.3.3
Δ_S	Component of <i>design story drift</i> corresponding to bolt slip deformation	E4.3.3
$\alpha, \alpha_1, \alpha_2$	Variables	E2.3.1.1.1
β	Coefficient	E1.4.1.4, E2.4.1.4
$\beta_1, \beta_2, \beta_3$	Variables	E2.3.1.1.1

SYMBOLS

Symbol	Definition	Section
δ	Calculated deflection, in in. (mm)	E1.4.1.4, E2.4.1.4
δ_v	Vertical deformation of anchorage/attachment details, in in. (mm)	E1.4.1.4, E2.4.1.4
ρ	Variable	E2.3.1.1.1
λ	Slenderness of compression element	A3.2.3
ϕ	<i>Resistance factor for LRFD and LSD</i>	B3.2
ϕ_v	<i>Resistance factor for LRFD and LSD</i>	E1.3.2, E2.3.2, E3.3.2, E5.3.3, E6.3.2, F1.4.2, F2.4.2
ρ	Coefficient	E1.4.1.4, E2.4.1.4
$\omega_1, \omega_2, \omega_3, \omega_4$	Variables	E1.4.1.4, E2.4.1.4
Ω	<i>Safety factor for ASD</i>	B3.2
Ω_E	Expected strength factor	E1.3.3, E2.3.3, E5.3.3
Ω_o	Overstrength factor	B1.1, B3.4, E1.3.3, E2.3.3, E2.4.1.3, E3.4.3, E4.3.1, E6.3.2
Ω_v	<i>Safety factor for ASD</i>	E1.3.2, E2.3.2, E3.3.2, E6.3.2, F1.4.2, F2.4.2

This Page is Intentionally Left Blank.

TABLE OF CONTENTS

**NORTH AMERICAN STANDARD FOR SEISMIC DESIGN OF
COLD-FORMED STEEL STRUCTURAL SYSTEMS
WITH SUPPLEMENT 1**

Disclaimer	ii
Preface	iii
Committees That Approve AISI S400-15.....	v
AISI Committee on Framing Standards (2015).....	v
Lateral Design Subcommittee (2015)	vi
Committees That Approve Supplement 1 to AISI S400-15	vii
AISI Committee on Framing Standards (2016).....	vii
Lateral Design Subcommittee (2016)	viii
NORTH AMERICAN STANDARD FOR SEISMIC DESIGN OF COLD-FORMED STEEL STRUCTURAL SYSTEMS WITH SUPPLEMENT 1	1
A. GENERAL	1
A1 Scope and Applicability.....	1
A1.1 Scope.....	1
A1.2 Applicability.....	1
A2 Definitions	2
A2.1 Terms.....	2
A3 Materials	7
A3.1 Material Specifications.....	7
A3.2 Expected Material Properties.....	8
A3.2.1 Material Expected Yield Stress [Probable Yield Stress].....	8
A3.2.2 Material Expected Tensile Strength [Probable Tensile Strength].....	8
A3.2.3 Material Modified Expected Yield Stress [Modified Probable Yield Stress]	9
A3.3 Consumables for Welding.....	9
A4 Structural Design Drawings and Specifications.....	9
A5 Reference Documents	10
B. GENERAL DESIGN REQUIREMENTS	12
B1 General Seismic Design Requirements.....	12
B1.1 General.....	12
B1.2 Load Path.....	12
B1.3 Deformation Compatibility of Members and Connections Not in the Seismic Force- Resisting System.....	12
B1.4 Seismic Load Effects Contributed by Masonry and Concrete Walls.....	12
B1.5 Seismic Load Effects From Other Concrete or Masonry Components	12
B2 Lateral Force-Resisting System.....	12
B3 Design Basis.....	13
B3.1 Nominal Strength [Resistance]	13
B3.2 Available Strength [Factored Resistance]	13
B3.3 Expected Strength [Probable Resistance].....	13
B3.4 Required Strength [Effects of Factored Loads].....	14
C. ANALYSIS.....	15
C1 Seismic Load Effects.....	15

D. GENERAL MEMBER AND CONNECTION DESIGN REQUIREMENTS.....	15
E. SEISMIC FORCE-RESISTING SYSTEMS	16
E1 Cold-Formed Steel Light Frame Shear Walls Sheathed With Wood Structural Panels	16
E1.1 Scope.....	16
E1.2 Basis of Design.....	16
E1.2.1 Designated Energy-Dissipating Mechanism.....	16
E1.2.2 Seismic Design Parameters [Seismic Force Modification Factors and Limitations] for Seismic Force-Resisting System	16
E1.2.3 Type I or Type II Shear Walls.....	16
E1.2.4 Seismic Load Effects Contributed by Masonry and Concrete Walls.....	17
E1.3 Shear Strength [Resistance].....	17
E1.3.1 Nominal Strength [Resistance].....	17
E1.3.1.1 Type I Shear Walls.....	17
E1.3.1.1.1 Wall Pier Limitations.....	18
E1.3.1.1.2 Both Wall Faces Sheathed With the Same Material and Fastener Spacing	18
E1.3.1.1.3 More Than a Single Sheathing Material or Fastener Configuration	18
E1.3.1.2 Type II Shear Walls	20
E1.3.1.2.1 Percent Full-Height Sheathing.....	20
E1.3.1.2.2 Maximum Opening Height Ratio.....	20
E1.3.2 Available Strength [Factored Resistance].....	20
E1.3.3 Expected Strength [Probable Resistance]	21
E1.4 System Requirements.....	21
E1.4.1 Type I Shear Walls	21
E1.4.1.1 Limitations for Tabulated Systems	21
E1.4.1.2 Required Strength [Effect of Factored Loads] for Chord Studs, Anchorage, and Collectors	22
E1.4.1.3 Required Strength [Effect of Factored Loads] for Foundations.....	22
E1.4.1.4 Design Deflection	23
E1.4.2 Type II Shear Walls.....	23
E1.4.2.1 Additional Limitations	23
E1.4.2.2 Required Strength [Effect of Factored Loads] for Chord Studs, Anchorage, and Collectors	24
E1.4.2.2.1 Collectors Connecting In-Plane Type II Shear Wall Segments.....	24
E1.4.2.2.2 Uplift Anchorage and Boundary Chord Forces at Type II Shear Wall Ends	24
E1.4.2.2.3 Uplift Anchorage Between Type II Shear Wall Ends.....	25
E1.4.2.3 Design Deflection	25
E2 Cold-Formed Steel Light Frame Shear Walls With Steel Sheet Sheathing	25
E2.1 Scope.....	25
E2.2 Basis of Design.....	25
E2.2.1 Designated Energy-Dissipating Mechanism.....	25
E2.2.2 Seismic Design Parameters [Seismic Force Modification Factors and Limitations] for Seismic Force-Resisting System	26
E2.2.3 Type I or Type II Shear Walls.....	26
E2.2.4 Seismic Load Effects Contributed by Masonry and Concrete Walls.....	26

E2.3	Shear Strength [Resistance]	27
E2.3.1	Nominal Strength [Resistance]	27
E2.3.1.1	Type I Shear Walls	27
E2.3.1.1.1	Effective Strip Method	27
E2.3.1.1.2	Wall Pier Limitations	28
E2.3.1.1.3	Both Wall Faces Sheathed With the Same Material and Fastener Spacing	29
E2.3.1.1.4	More Than a Single Sheathing Material or Fastener Configuration	29
E2.3.1.2	Type II Shear Walls	31
E2.3.1.2.1	Percent Full-Height Sheathing	31
E2.3.1.2.2	Maximum Opening Height Ratio	31
E2.3.2	Available Strength [Factored Resistance]	31
E2.3.3	Expected Strength [Probable Resistance]	32
E2.4	System Requirements	32
E2.4.1	Type I Shear Walls	32
E2.4.1.1	Limitations for Tabulated Systems	32
E2.4.1.2	Required Strength [Effect of Factored Loads] for Chord Studs, Anchorage, and Collectors	33
E2.4.1.3	Required Strength [Effect of Factored Loads] for Foundations	34
E2.4.1.4	Design Deflection	34
E2.4.2	Type II Shear Walls	35
E2.4.2.1	Additional Limitations	35
E2.4.2.2	Required Strength [Effects of Factored Loads] for Chord Studs, Anchorage, and Collectors	35
E2.4.2.2.1	Collectors Connecting In-Plane Type II Shear Wall Segments	35
E2.4.2.2.2	Uplift Anchorage and Boundary Chord Forces at Type II Shear Wall Ends	36
E2.4.2.2.3	Uplift Anchorage Between Type II Shear Wall Ends	36
E2.4.2.3	Design Deflection	36
E3	Cold-Formed Steel Light Frame Strap Braced Wall Systems	37
E3.1	Scope	37
E3.2	Basis of Design	37
E3.2.1	Designated Energy-Dissipating Mechanism	37
E3.2.2	Seismic Design Parameters [Seismic Force Modification Factors and Limitations] for Seismic Force-Resisting System	37
E3.2.3	Seismic Load Effects Contributed by Masonry and Concrete Walls	37
E3.3	Shear Strength [Resistance]	38
E3.3.1	Nominal Strength [Resistance]	38
E3.3.2	Available Strength [Factored Resistance]	38
E3.3.3	Expected Strength [Probable Resistance]	38
E3.4	System Requirements	38
E3.4.1	Limitations on System	38
E3.4.2	Required Strength [Effect Due to Factored Loads] for Seismic Force-Resisting System	39
E3.4.3	Required Strength [Effect Due to Factored Loads] for Foundations	40
E3.4.4	Design Deflection	40

E4 Cold-Formed Steel Special Bolted Moment Frames (CFS-SBMF).....	40
E4.1 Scope.....	40
E4.2 Basis of Design.....	40
E4.2.1 Designated Energy-Dissipating Mechanism.....	40
E4.2.2 Seismic Design Parameters for Seismic Force-Resisting System.....	40
E4.2.3 Seismic Load Effects Contributed by Masonry and Concrete Walls.....	41
E4.3 Strength.....	41
E4.3.1 Required Strength.....	41
E4.3.1.1 Beams and Columns.....	41
E4.3.1.2 Bolt Bearing Plates.....	41
E4.3.2 Available Strength.....	41
E4.3.3 Expected Strength.....	42
E4.4 System Requirements.....	44
E4.4.1 Limitations on System.....	44
E4.4.2 Beams.....	44
E4.4.3 Columns.....	44
E4.4.4 Connections, Joints and Fasteners.....	45
E4.4.4.1 Bolted Joints.....	45
E4.4.4.1.1 Beam-to-Column Connections.....	45
E4.4.4.1.2 Bolt Bearing Plates.....	45
E4.4.4.2 Welded Joints.....	45
E4.4.4.3 Other Joints and Connections.....	45
E5 Cold-Formed Steel Light Frame Shear Walls With Wood-Based Structural Panel Sheathing on One Side and Gypsum Board Panel Sheathing on the Other Side.....	46
E5.1 Scope.....	46
E5.2 Basis of Design.....	46
E5.2.1 Designated Energy-Dissipating Mechanism.....	46
E5.2.2 Seismic Force Modification Factors and Limitations for Seismic Force-Resisting System.....	46
E5.2.3 Type I Shear Walls.....	46
E5.2.4 Seismic Load Effects Contributed by Masonry and Concrete Walls.....	46
E5.3 Shear Resistance.....	47
E5.3.1 Nominal Resistance.....	47
E5.3.1.1 Type I Shear Walls.....	47
E5.3.1.1.1 Both Wall Faces Sheathed With the Same Material and Fastener Spacing.....	47
E5.3.2 Factored Resistance.....	47
E5.3.3 Probable Resistance.....	48
E5.4 System Requirements.....	48
E5.4.1 Type I Shear Walls.....	48
E5.4.1.1 Limitations for Tabulated Systems.....	48
E5.4.1.2 Effect of Factored Loads for Chord Studs, Anchorage, and Collectors.....	49
E5.4.1.3 Effect of Factored Loads for Foundations.....	49
E5.4.1.4 Design Deflection.....	49
E6 Cold-Formed Steel Light Frame Shear Walls With Gypsum Board or Fiberboard Panel Sheathing.....	50
E6.1 Scope.....	50

E6.2	Basis of Design	50
E6.2.1	Designated Energy-Dissipating Mechanism.....	50
E6.2.2	Seismic Design Parameters for Seismic Force-Resisting System.....	50
E6.2.3	Type I Shear Walls	50
E6.2.4	Seismic Load Effects Contributed by Masonry and Concrete Walls	50
E6.3	Shear Strength.....	50
E6.3.1	Nominal Strength.....	50
E6.3.1.1	Type I Shear Walls.....	50
E6.3.1.1.1	Both Wall Faces Sheathed With the Same Material and Fastener Spacing	51
E6.3.1.1.2	More Than a Single Sheathing Material or Fastener Configuration	51
E6.3.2	Available Strength	52
E6.3.3	Expected Strength.....	52
E6.4	System Requirements.....	52
E6.4.1	Type I Shear Walls	52
E6.4.1.1	Limitations for Tabulated Systems	52
E6.4.1.2	Required Strength for Chord Studs, Anchorage, and Collectors	53
E6.4.1.3	Required Strength for Foundations	54
E6.4.1.4	Design Deflection	54
E7	Conventional Construction Cold-Formed Steel Light Frame Strap Braced Wall Systems	55
E7.1	Scope.....	55
E7.2	Basis of Design.....	55
E7.2.1	Designated Energy-Dissipating Mechanism.....	55
E7.2.2	Seismic Force Modification Factors and Limitations for Seismic Force-Resisting System.....	55
E7.2.3	Wall Aspect Ratio.....	55
E7.2.4	Seismic Load Effects Contributed by Masonry and Concrete Walls	55
E7.3	Shear Resistance.....	55
E7.3.1	Nominal Resistance	55
E7.3.2	Factored Resistance.....	55
E7.4	System Requirements.....	56
E7.4.1	Limitations on System.....	56
E7.4.2	Effect of Eccentricity	56
E7.4.3	Design Deflection.....	56
F.	DIAPHRAGMS.....	57
F1	General.....	57
F1.1	Scope.....	57
F1.2	Design Basis.....	57
F1.3	Required Strength	57
F1.3.1	Diaphragm Stiffness	57
F1.3.2	Seismic Load Effects Including Overstrength.....	57
F1.4	Shear Strength.....	57
F1.4.1	Nominal Strength.....	57
F1.4.1.1	Diaphragms Sheathed With Wood Structural Panels	57
F1.4.2	Available Strength	57
F2	Cold-Formed Steel Diaphragms Sheathed With Wood Structural Panels	58

F2.1	Scope.....	58
F2.2	Additional Design Requirements.....	58
	F2.2.1 Seismic Detailing Requirements.....	58
	F2.2.2 Seismic Load Effects Contributed by Masonry and Concrete Walls.....	58
F2.3	Required Strength.....	58
	F2.3.1 Diaphragm Stiffness.....	58
F2.4	Shear Strength.....	58
	F2.4.1 Nominal Strength.....	58
	F2.4.1.1 Requirements for Tabulated Systems.....	59
	F2.4.2 Available Strength.....	59
	F2.4.3 Design Deflection.....	60
F2.5	Requirements Where the Seismic Response Modification Coefficient, R , is Greater Than Three.....	60
	F2.5.1 Open Front Structures.....	61
	F2.5.2 Member Requirements.....	61
F3	Other Diaphragms.....	61
	G. QUALITY CONTROL AND QUALITY ASSURANCE.....	62
G1	Cold-Formed Steel Light Frame Shear Walls Sheathed With Wood Structural Panels.....	62
G2	Cold-Formed Steel Light Frame Shear Walls Sheathed with Steel Sheets.....	62
G3	Cold-Formed Steel Light Frame Strap Braced Wall Systems.....	62
G4	Cold-Formed Steel Special Bolted Moment Frames (CFS-SBMF).....	62
	G4.1 Cooperation.....	62
	G4.2 Rejections.....	62
	G4.3 Inspection of Welding.....	62
	G4.4 Inspection of Bolted Connections.....	63
	G4.5 Identification of Steel.....	63
G5	Cold-Formed Steel Light Frame Shear Walls Sheathed With Wood-Based Structural Panels and Gypsum Board Panels in Combination.....	63
G6	Cold-Formed Steel Light Frame Shear Walls Sheathed With Gypsum Board or Fiberboard Panels.....	63
	H. USE OF SUBSTITUTE COMPONENTS AND CONNECTIONS IN SEISMIC FORCE-RESISTING SYSTEMS.....	64
	APPENDIX 1, SEISMIC FORCE MODIFICATION FACTORS AND LIMITATIONS IN CANADA.....	65
1.1	Scope and Applicability.....	65
1.2	Seismic Force Modification Factors and Limitations in Canada.....	65

NORTH AMERICAN STANDARD FOR SEISMIC DESIGN OF COLD-FORMED STEEL STRUCTURAL SYSTEMS WITH SUPPLEMENT 1

A. GENERAL

A1 Scope and Applicability

A1.1 Scope

This *Standard* is applicable for the design and construction of *cold-formed steel structural members and connections in seismic force-resisting systems and diaphragms* in buildings and other structures.

A1.2 Applicability

A1.2.1 This *Standard* shall be applied in conjunction with AISI S100 [CSA S136], AISI S240 and the *applicable building code*.

A1.2.2 In the absence of an *applicable building code*, the design requirements shall be in accordance with accepted engineering practice for the location under consideration as specified by the applicable sections of ASCE 7 in the U.S. and Mexico, or the *National Building Code of Canada* (NBCC) in Canada.

A1.2.3 In the U.S. and Mexico, in *seismic design categories* B or C and where the *seismic response modification coefficient*, R , used to determine the seismic design forces is taken equal to 3, the *cold-formed steel structural members and connections in lateral force-resisting systems* need only be designed in accordance with AISI S100 or AISI S240, as applicable. In Canada, where the *seismic force modification factors*, R_dR_o , used to determine the seismic design forces, are taken as less than 1.56 or the design spectral response acceleration $S(0.2)$ as specified in the NBCC is less than or equal to 0.12, the *cold-formed steel structural members and connections in lateral force-resisting systems* need only be designed in accordance with CSA S136 or AISI S240, as applicable.

User Note:

This *Standard* intends to exempt *lateral force-resisting system* only where the *seismic design category* is B or C and the *seismic response modification coefficient*, R , equals 3. ASCE 7, Table 12.2-1, Line H exempts these steel systems from seismic detailing requirements in this *Standard* as long as they are designed in accordance with AISI S240 or AISI S100, as applicable. For *seismic design category* A, it is not necessary to define a *seismic force-resisting system* that meets any special requirements and this *Standard* does not apply.

User Note:

In Canada, the NBCC sets the *seismic force modification factors*, R_dR_o , for “Other Cold-Formed Steel Seismic Force-Resisting System(s)” equal to 1.0, which is the only system with R_dR_o under 1.56. Systems falling into this category need only be designed in accordance with CSA S136 or AISI S240 as appropriate.

A1.2.4 Elements not specifically addressed by this *Standard* shall be constructed in accordance with *applicable building code* requirements.

A1.2.5 This *Standard* does not preclude the use of other materials, assemblies, structures or

designs not meeting the criteria herein, when the other materials, assemblies, structures or designs demonstrate equivalent performance for the intended use to those specified in this *Standard*. Where there is a conflict between this *Standard* and other reference documents, the requirements contained within this *Standard* shall govern.

A1.2.6 This *Standard* includes Chapters A through H and Appendix 1 in their entirety.

A2 Definitions

A2.1 Terms

Where the following terms appear in this *Standard* in italics, they shall have the meaning herein indicated. Where a country is indicated in square brackets following the definition, the definition shall apply only in the country indicated. Terms included in square brackets shall be specific to LSD terminology. Terms not defined in Section A2.1 shall have the ordinary accepted meaning for the intended context.

ASD (Allowable Strength Design). Method of proportioning *structural components* such that the *allowable strength* equals or exceeds the *required strength* of the *component* under the action of the *ASD load combinations*. [USA and Mexico]

ASD Load Combination. *Load combination* in the *applicable building code* intended for *allowable strength design* (allowable stress design). [USA and Mexico]

Allowable Strength. *Nominal strength* divided by the *safety factor*, R_n/Ω . [USA and Mexico]

Applicable Building Code. The building code under which the structure is designed.

Approved. Acceptable to the *authority having jurisdiction*.

Authority Having Jurisdiction. The organization, office, or individual responsible for enforcing the requirements of this *Standard*, or for approving materials, an installation, or a procedure.

User Note:

In Canada, the regulatory authority functions as the *authority having jurisdiction*. It is defined as the federal, provincial/territorial, or municipal ministry, department, board, agency, or commission that is responsible for regulating by statute the use of products, materials, or services.

Available Strength. *Design strength* or *allowable strength* as appropriate. [USA and Mexico]

Base Steel Thickness. The thickness of bare steel exclusive of all coatings.

Bearing (Local Compressive). Limit state of local compressive yielding due to the action of a member bearing against another member or surface.

Blocking. *C-shaped member*, break shape, flat *strap* material, or *component* assemblies attached to *structural members*, flat *strap* or sheathing panels to transfer shear forces or stabilize members.

Blocking, Panel. *Blocking* that transmits shear between the panels of a *shear wall* or *diaphragm*.

Blocking, Stud. *Blocking* that provides torsional support to the *studs* in a *shear wall*.

Boundary Elements. Portions along wall and *diaphragm* edges for transferring or resisting forces. *Boundary elements* include *chords* and *collectors* (drag struts) at *diaphragm*, *strap braced wall* and *shear wall* perimeters, edges of openings, discontinuities and re-entrant corners.

Bracing. Structural elements that are installed to provide restraint or support (or both) to

other *structural members* or *nonstructural members* so that the complete assembly forms a stable structure.

Capacity-Based Design. Design of *lateral force-resisting systems* according to capacity design principles to resist the maximum anticipated seismic loads.

User Note:

Capacity design principles for design of a *seismic force-resisting system* include all of the following: a) specific elements or mechanisms are designed to dissipate energy; b) all other elements are sufficiently strong for this energy dissipation to be achieved; c) structural integrity is maintained; d) elements and *connections* in the horizontal and vertical load paths are designed to resist these seismic loads and corresponding principal and companion loads as defined by the NBCC; e) *diaphragms* and *collector* elements are capable of transmitting the *loads* developed at each level to the vertical *seismic force-resisting system*; and f) these *loads* are transmitted to the foundation. [Canada]

Chord. Member of a *shear wall*, *strap braced wall* or *diaphragm* that forms the perimeter, interior opening, discontinuity or re-entrant corner.

Chord Stud. Axial load-bearing *studs* located at the ends of *Type I shear walls* or *Type II shear wall segments*, or *strap braced walls*.

Cold-Formed Sheet Steel. Sheet steel or strip steel that is manufactured by (1) press braking blanks sheared from sheets or cut length of coils or plates, or by (2) continuous roll forming of cold- or hot-rolled coils of sheet steel; both forming operations are performed at ambient room temperature, that is, without any addition of heat such as would be required for hot forming.

Cold-Formed Steel. See *Cold-Formed Sheet Steel*.

Collector. Also known as a drag strut, a member parallel to the applied *load* that serves to transfer forces between *diaphragms* and members of the *lateral force-resisting system* or distributes forces within the *diaphragm* or *seismic force-resisting system*.

Component. See *Structural Component*.

Connection. Combination of structural elements and *joints* used to transmit forces between two or more members.

Connector. A device used to transmit forces between *cold-formed steel structural members*, or between a *cold-formed steel structural member* and another structural element.

Construction Documents. Written, graphic and pictorial documents prepared or assembled for describing the design (including the structural system), location and physical characteristics of the elements of a building necessary to obtain a building permit and construct a building.

C-Shape. A *cold-formed steel* shape used for *structural members* and *nonstructural members* consisting of a *web*, two (2) *flanges* and two (2) *lips* (edge stiffeners).

Design Earthquake. The ground motion represented by the design response spectrum as specified in the *applicable building code*.

Design Load. Applied *load* determined in accordance with either *LRFD load combinations* or *ASD load combinations*, whichever is applicable. [USA and Mexico]

Design Strength. *Resistance factor* multiplied by the *nominal strength*. [USA and Mexico]

Design Story Drift. Calculated story drift, including the effect of expected inelastic action, due to design level earthquake forces as determined by the *applicable building code*.

Designated Energy Dissipating Mechanism. Selected portion of the *seismic force-resisting system* designed and detailed to dissipate energy.

Designation Thickness. The minimum *base steel thickness* expressed in *mils* and rounded to a whole number.

Diaphragm. Roof, floor or other membrane or *bracing system* that transfers in-plane forces to the *seismic force-resisting system*. [USA and Mexico]

Diaphragm. Roof, floor or other membrane or *bracing system* that transfers in-plane forces to the wall elements as part of the *seismic force-resisting system*. [Canada]

Factored Load. Product of a *load factor* and the *nominal load* [specified load].

Factored Resistance. Product of *nominal resistance* and appropriate *resistance factor*. [Canada]

Fiberboard. A fibrous, homogeneous panel made from lignocellulosic fibers (usually wood or cane) and having a density of less than 31 pounds per cubic foot (pcf) (497 kg/m³) but more than 10 pcf (160 kg/m³).

Flange. For a *C-shape*, *U-shape* or *track*, that portion of the *structural member* or *nonstructural member* that is perpendicular to the *web*. For a *furring channel*, that portion of the *structural member* or *nonstructural member* that connects the *webs*.

Hold-Down (Tie-Down). A device used to resist overturning forces in a *shear wall*, *strap braced wall*, or uplift forces in a *cold-formed steel structural member*. For the purposes of this *Standard*, it is a *component* of the *seismic force-resisting system*.

Joint. Area where two or more ends, surfaces or edges are attached. Categorized by type of fastener or weld used and the method of force transfer.

Lateral Force-Resisting System. The structural elements and *connections* required to resist racking and overturning due to wind forces or seismic forces, or other predominantly horizontal forces, or combination thereof, imposed upon the structure in accordance with the *applicable building code*.

Limit States. Those conditions in which a *structural member* ceases to fulfill the function for which it was designed. Those states concerning safety are called the ultimate limit states. The ultimate limit state for resistance is the maximum *load-carrying capacity*. Limit states that restrict the intended use of a member for reasons other than safety are called serviceability limit states. [Canada]

User Note:

Ultimate limit states include overturning, sliding, fracturing, and exceeding load-carrying capacity. Serviceability limit states include deflection, vibration, and permanent deformation.

LSD (Limit States Design). Method of proportioning *structural components* (members, *connectors*, connecting elements and assemblages) such that no applicable *limit state* is exceeded when the structure is subjected to all appropriate *load combinations*. [Canada]

Lip. That part of a *structural member* or *nonstructural member* that extends from the *flange* as a stiffening element.

Load. Force or other action that results from the weight of building materials, occupants and their possessions, environmental effects, differential movement, or restrained dimensional changes.

Load Effect. Forces, stresses, and deformations produced in a *structural component* by the applied loads.

- Load Factor.* A factor defined by the *applicable building code* to take into account the variability in loads and the analysis of their effects. [USA and Mexico]
- LRFD (Load and Resistance Factor Design).* Method of proportioning *structural components* such that the *design strength* equals or exceeds the *required strength* of the *component* under the action of the *LRFD load combinations*. [USA and Mexico]
- LRFD Load Combination.* Load combination in the *applicable building code* intended for strength design (*Load and Resistance Factor Design*). [USA and Mexico]
- Moment Frame.* Framing system that provides resistance to lateral loads and provides stability to the structural system primarily by shear and flexure of the *structural members* and their *connections*.
- Nominal Load.* Magnitude of the *load* specified by the *applicable building code*. [USA and Mexico]
- Nominal Resistance (Resistance).* Capacity of a structure or *component* to resist the effects of loads, determined in accordance with this *Standard* using specified material strengths and dimensions. [Canada]
- Nominal Strength.* Strength of a structure or *component* (without the *resistance factor* or *safety factor* applied) to resist the *load effects*, as determined in accordance with this *Standard*. [USA and Mexico]
- Nonstructural Member.* A member in a steel-framed system that is not a part of the gravity load-resisting system, *lateral force-resisting system* or building envelope.
- Owner.* The individual or entity organizing and financing the design and construction of the project.
- Owner's Representative.* The *owner* or individual designated contractually to act for the *owner*.
- Other Structures.* Structures designed and constructed in a manner similar to buildings, with building-like vertical and lateral load-resisting elements.
- Quality Control.* Controls and inspections implemented by the *component manufacturer* or *installer* to confirm that the material provided and work performed meet the requirements of the *approved construction documents* and referenced standards.
- Rational Engineering Analysis.* Analysis based on theory that is appropriate for the situation, any relevant test data, if available, and sound engineering judgment.
- Registered Design Professional.* Architect or engineer who is licensed to practice their respective design profession as defined by the legal requirements of the jurisdiction in which the building is to be constructed.
- Required Strength.* Forces, stresses, and deformations produced in a *structural component*, determined by either structural analysis, for the *LRFD* or *ASD load combinations*, as appropriate, or as specified by this *Standard*. [USA and Mexico]
- Resistance Factor (ϕ).* Factor that accounts for unavoidable deviations of the actual strength [resistance] from the *nominal strength* [*nominal resistance*] and for the manner and consequences of failure.
- Risk Category.* A categorization of buildings and *other structures* for determination of flood, wind, snow, ice, and earthquake loads based on the risk associated with unacceptable performance.
- Safety Factor (Ω).* Factor that accounts for the desired level of safety, including deviations of

the actual *load* from the *nominal load* and uncertainties in the analysis that transforms the *load* into a *load effect*, in determining the *nominal strength* and for the manner and consequences of failure. [USA and Mexico]

Seismic Design Category (SDC). A classification assigned by the *applicable building code* to a structure based on its *risk category* and the severity of the *design earthquake* ground motion at the site. [USA and Mexico]

Seismic Force Modification Factors, R_d and R_o . Factors that reduce seismic *load effects* to strength level for ductility and overstrength respectively, as specified by the *applicable building code*. [Canada]

Seismic Force-Resisting System (SFRS). That part of the structural system that has been selected in the design to provide energy dissipation and the required resistance to the seismic forces prescribed in the *applicable building code*.

Seismic Response Modification Coefficient, R . Factor that reduces seismic *load effects* to strength level as specified by the *applicable building code*. [USA and Mexico]

Shear Wall. A wall with structural sheathing attached to *cold-formed steel structural members* and designed to primarily resist lateral forces parallel to the wall.

Snug-Tightened Bolt. Bolt in a *joint* in which tightness is attained by either a few impacts of an impact wrench, or the full effort of a worker with an ordinary spud wrench, that brings the connected plies into firm contact.

Specified Minimum Yield Stress. Lower limit of *yield stress* specified for a material as defined by ASTM.

Specified Minimum Tensile Strength. Lower limit of tensile strength specified for a material as defined by ASTM.

Steel Sheet Sheathing. A panel of thin flat steel sheet.

Strap. Flat or coiled sheet steel material typically used for *bracing* or *blocking* which transfers loads by tension or shear.

Strap-Braced Wall. Wall designed to resist in-plane lateral forces that is braced by *strap bracing* and is provided with *hold-downs* and anchorage at each end of the wall segment.

Strap Bracing. Steel straps, applied diagonally, to form a vertical *truss* that forms part of the *lateral force-resisting system*.

Structural Component. Member, *connector*, connecting element or assemblage.

Structural Member. A member that resists *design loads* [*factored loads*] as required by the *applicable building code*, except when defined as a *nonstructural member*.

Stud. A vertical *structural member* or *nonstructural member* in a wall system or assembly.

Track. A *structural member* or *nonstructural member* consisting of only a *web* and two (2) *flanges*. *Track web* depth measurements are taken to the inside of the *flanges*.

Type I Shear Wall. Wall designed to resist in-plane lateral forces that is fully sheathed and that is provided with *hold-downs* and anchorage at each end of the wall segment.

Type II Shear Wall. Wall designed to resist in-plane lateral forces that is sheathed with *wood structural panels* or *steel sheet sheathing* that contains openings, but which has not been specifically designed and detailed for force transfer around wall openings. *Hold-downs* and anchorage for *Type II shear walls* are only required at the ends of the wall.

Type II Shear Wall Segment. Section of *shear wall* (within a *Type II shear wall*) with full-height sheathing (i.e., with no openings) and which meets specific aspect ratio limits.

Wall Pier. A section of a *Type I shear wall* adjacent to an opening and equal in height to the opening, which is designed to resist lateral forces in the plane of the wall.

Web. That portion of a *structural member* or *nonstructural member* that connects the *flanges*.

Wood Structural Panel. A panel manufactured from veneers, wood strands or wafers or a combination of veneer and wood strands or wafers bonded together with waterproof synthetic resins or other suitable bonding systems.

A3 Materials

A3.1 Material Specifications

Structural members utilized in *cold-formed steel seismic force-resisting systems* shall be manufactured from steel complying with the requirements of one of the following ASTM specifications, subject to the additional limitations specified in Chapter E and Chapter F:

ASTM A36/A36M, *Standard Specification for Carbon Structural Steel*

ASTM A242/A242M, *Standard Specification for High-Strength Low-Alloy Structural Steel*

ASTM A283/A283M, *Standard Specification for Low and Intermediate Tensile Strength Carbon Steel Plates*

ASTM A500 (Grade B or C), *Standard Specification for Cold-Formed Welded and Seamless Carbon Steel Structural Tubing in Rounds and Shapes*

ASTM A529/A529M, *Standard Specification for High-Strength Carbon-Manganese Steel of Structural Quality*

ASTM A572/A572M (Grade 42 (290), 50 (345), or 55 (380)), *Standard Specification for High-Strength Low-Alloy Columbium-Vanadium Structural Steel*

ASTM A588/A588M, *Standard Specification for High-Strength Low-Alloy Structural Steel With 50 ksi [345 MPa] Minimum Yield Point to 4-in. [100 mm] Thick*

ASTM A606, *Standard Specification for Steel, Sheet and Strip, High-Strength, Low-Alloy, Hot-Rolled and Cold-Rolled, With Improved Atmospheric Corrosion Resistance*

ASTM A653/A653M (SS Grades 33 (230), 37 (255), 40 (275), and 50 (340) Class 1 and Class 3; HSLAS Types A and B, Grades 40 (275), 50 (340), 55 (380) Class 1 and 2, 60 (410)), *Standard Specification for Steel Sheet, Zinc-Coated (Galvanized) or Zinc-Iron Alloy-Coated (Galvannealed) by the Hot-Dip Process*

ASTM A792/A792M (Grades 33 (230), 37 (255), 40 (275), and 50 Class 1 (340 Class 1)), *Standard Specification for Steel Sheet, 55% Aluminum-Zinc Alloy-Coated by the Hot-Dip Process*

ASTM A875/A875M (SS Grades 33 (230), 37 (255), 40 (275), and 50 (340) Class 1 and Class 3; HSLAS Types A and B, Grades 50 (340), 60 (410)), *Standard Specification for Steel Sheet, Zinc-5% Aluminum Alloy-Coated by the Hot-Dip Process*

ASTM A1003/A1003M (Grades ST33H, ST37H, ST40H, ST50H), *Standard Specification for Steel Sheet, Carbon, Metallic- and Nonmetallic-Coated for Cold-Formed Framing Members*

ASTM A1008/A1008M (SS Grades 25 (170), 30 (205), 33 (230) Types 1 and 2, and 40 (275) Types 1 and 2; HSLAS Classes 1 and 2, Grades 45 (310), 50 (340), 55 (380), 60 (410), and 65 (450)); HSLAS-F Grades 50 (340), 60 (410)), *Standard Specification for Steel, Sheet, Cold-Rolled, Carbon, Structural, High-Strength Low-Alloy, High-Strength Low-Alloy with Improved*

Formability, Solution Hardened, and Bake Hardenable

ASTM A1011/A1011M (SS Grades 30 (205), 33 (230), 36 (250) Types 1 and 2, 40 (275), 45 (310), 50 (340), and 55 (380); HSLAS Classes 1 and 2, Grades 45 (310), 50 (340), 55 (380), 60 (410), and 65 (450)); HSLAS-F Grades 50 (340), and 60 (410)), *Standard Specification for Steel, Sheet and Strip, Hot-Rolled, Carbon, Structural, High-Strength Low-Alloy and High-Strength Low-Alloy With Improved Formability*

ASTM A1085, *Standard Specification for Cold-Formed Welded Carbon Steel Hollow Structural Sections (HSS)*

A3.2 Expected Material Properties

A3.2.1 Material Expected Yield Stress [Probable Yield Stress]

Where required in this *Standard*, the expected strength [probable resistance] of a *connection* or *structural member* shall be determined using the expected yield stress [probable yield stress], $R_y F_y$, with R_y given in Table A3.2-1, unless otherwise modified in Chapter E and Chapter F.

Values of R_y , other than those listed in Table A3.2-1, are permitted to be used, if the values are determined by testing specimens representative of the product thickness and source, and such tests are conducted in accordance with the requirements for the specified grade of steel in Section A3.1.

Table A3.2-1
 R_y and R_t Values for Various Product Types

Steel	R_y	R_t
Plates and bars: A36/A36M, A283/A283M	1.3	1.2
A242/A242M, A529/A529M, A572/A572M, A588/A588M	1.1	1.2
Hollow Structural Sections: A500 Grade B	1.4	1.3
A500 Grade C	1.3	1.2
A1085	1.25	1.15
Sheet and strip (A606, A653/A653M, A792/A792M, A875, A1003/A1003M, A1008/A1008M, A1011/A1011M):		
$F_y < 37$ ksi (255 MPa)	1.5	1.2
37 ksi (255MPa) $\leq F_y < 40$ ksi (275 MPa)	1.4	1.1
40 ksi (275MPa) $\leq F_y < 50$ ksi (340 MPa)	1.3	1.1
$F_y \geq 50$ ksi(340 MPa)	1.1	1.1

A3.2.2 Material Expected Tensile Strength [Probable Tensile Strength]

Where required in this *Standard*, the expected strength [probable resistance] of a *connection* or *structural member* shall be determined using the expected tensile strength [probable tensile strength], $R_t F_u$ with R_t given in Table A3.2-1, unless otherwise modified in Chapter E and Chapter F.

Values of R_t other than those listed in Table A3.2-1, are permitted to be used, if the values are determined by testing specimens representative of the product thickness and source, and such tests are conducted in accordance with the requirements for the specified grade of steel in Section A3.1.

A3.2.3 Material Modified Expected Yield Stress [Modified Probable Yield Stress]

Where required in this *Standard*, the expected strength [probable resistance] of a flexural member shall be determined from the modified expected yield stress [modified probable yield stress], $R_{re}R_{cf}R_yF_y$.

The factor to account for increase in yield stress above the nominal specified yield stress, R_y , shall be determined in accordance with Section A3.2.1.

The factor to account for the increase in yield stress due to cold work of forming, averaged over the cross section, R_{cf} , shall be taken as F_{ya}/F_y , where F_{ya} is determined in accordance with Section A7.2 of AISI S100 [CSA S136]. R_{cf} shall not be taken less than 1.1.

The factor considering the inelastic reserve capacity for a fully effective section in bending, R_{re} , shall be determined as follows:

For $\lambda < 0.673$,

$$R_{re} = M_{no}/M_y \quad (\text{Eq. A3.2.3-1})$$

For $\lambda \geq 0.673$,

$$R_{re} = 1$$

where

λ = Slenderness of compression *flange* of member considered, as defined in accordance with AISI S100

M_{no} = Nominal strength [resistance] determined in accordance with Section C3.1.1(b) of AISI S100 [CSA S136], if applicable, or M_y

$$M_y = \text{Nominal flexural yield strength [resistance]} \\ = S_f F_y \quad (\text{Eq. A3.2.3-2})$$

where

S_f = Full unreduced section modulus at yield stress, F_y

F_y = Specified minimum yield stress

A3.3 Consumables for Welding

All welds used in members and *connections* in the *seismic force-resisting system* shall be made in accordance with the requirements of AWS D1.1/D1.1M, AWS D1.3/D1.3M, *Structural Welding Code – Sheet Steel*, or CSA W59, as applicable, unless otherwise modified in Chapter E and Chapter F.

Electrodes shall be approved for use in resisting seismic forces.

A4 Structural Design Drawings and Specifications

Structural design drawings and specifications shall indicate the work to be performed, and include items required by AISI S100 [CSA S136], AISI S240, the *applicable building code*, and the following, as applicable:

- (a) Designation of the *seismic force-resisting system*,
- (b) Identification of the *structural members and connections* that are part of the *seismic force-resisting system*, and
- (c) *Connection details* between *diaphragms* and the elements of the *seismic force-resisting system*.

A5 Reference Documents

The following documents or portions thereof are referenced in this *Standard* and shall be considered part of the requirements of this *Standard*:

1. American Institute of Steel Construction (AISC), One East Wacker Drive, Suite 700, Chicago, IL 60601-1802:
 - ANSI/AISC 341-10, *Seismic Provisions for Structural Steel Buildings*, June 22, 2010
 - ANSI/AISC 360-10, *Specification for Structural Steel Buildings*, Chicago, IL, June 22, 2010
2. American Iron and Steel Institute (AISI), 25 Massachusetts Avenue, NW, Suite 800, Washington, DC 20001:
 - AISI S100-12, *North American Specification for the Design of Cold-Formed Steel Structural Members*, 2012
 - AISI S240-15, *North American Standard for Cold-Formed Steel Structural Framing*, 2015
3. American Society of Civil Engineers, 1801 Alexander Bell Drive, Reston, Virginia 20191-4400:
 - ASCE/SEI 7-10 With Supplement 1-12, *Minimum Design Loads for Buildings and Other Structures*
4. ASTM International, 100 Barr Harbor Drive, West Conshohocken, PA 19428-2959:
 - ASTM A36/A36M-14, *Standard Specification for Carbon Structural Steel*
 - ASTM A242/A242M-13, *Standard Specification for High-Strength Low-Alloy Structural Steel*
 - ASTM A283/A283M-13, *Standard Specification for Low and Intermediate Tensile Strength Carbon Steel Plates*
 - ASTM A500-13, *Standard Specification for Cold-Formed Welded and Seamless Carbon Steel Structural Tubing in Rounds and Shapes*
 - ASTM A529/A529M-14, *Standard Specification for High-Strength Carbon-Manganese Steel of Structural Quality*
 - ASTM A572/A572M-15, *Standard Specification for High-Strength Low-Alloy Columbium-Vanadium Structural Steel*
 - ASTM A588/A588M-15, *Standard Specification for High-Strength Low-Alloy Structural Steel With 50 ksi [345 MPa] Minimum Yield Point, With Atmosphere Corrosion Resistance*
 - ASTM A606-09a, *Standard Specification for Steel, Sheet and Strip, High-Strength, Low-Alloy, Hot-Rolled and Cold-Rolled, With Improved Atmospheric Corrosion Resistance*
 - ASTM A653/A653M-15, *Standard Specification for Steel Sheet, Zinc-Coated (Galvanized) or Zinc-Iron Alloy-Coated (Galvannealed) by the Hot-Dip Process*
 - ASTM A792/A792M-10, *Standard Specification for Steel Sheet, 55% Aluminum-Zinc Alloy-Coated by the Hot-Dip Process*
 - ASTM A875/A875M-13, *Standard Specification for Steel Sheet, Zinc-5% Aluminum Alloy-Coated by the Hot-Dip Process*

- ASTM A1003/A1003M-15, *Standard Specification for Steel Sheet, Carbon, Metallic- and Nonmetallic-Coated for Cold-Formed Framing Members*
- ASTM A1008/A1008M-15, *Standard Specification for Steel, Sheet, Cold-Rolled, Carbon, Structural, High-Strength Low-Alloy and High-Strength Low-Alloy With Improved Formability, Solution Hardened and Bake Hardenable*
- ASTM A1011/A1011M-14, *Standard Specification for Steel, Sheet and Strip, Hot-Rolled, Carbon, Structural, High-Strength Low-Alloy and High-Strength Low-Alloy With Improved Formability, and Ultra-High Strength*
- ASTM A1085-13, *Standard Specification for Cold-Formed Welded Carbon Steel Hollow Structural Sections (HSS)*
- ASTM C208-12, *Standard Specification for Cellulosic Fiber Insulating Board*
- ASTM C954-15, *Standard Specification for Steel Drill Screws for the Application of Gypsum Panel Products or Metal Plaster Bases to Steel Studs From 0.033 in. (0.84 mm) to 0.112 in. (2.84 mm) in Thickness*
- ASTM C1002-14, *Standard Specification for Steel Self-Piercing Tapping Screws for the Application of Gypsum Panel Products or Metal Plaster Bases to Wood Studs or Steel Studs*
- ASTM C1396/C1396M-14a, *Standard Specification for Gypsum Board*
- ASTM C1513-13, *Standard Specification for Steel Tapping Screws for Cold-Formed Steel Framing Connections*
- ASTM E2126-11, *Standard Test Methods for Cyclic (Reversed) Load Test for Shear Resistance of Vertical Elements of the Lateral Force Resisting Systems for Buildings*
5. American Welding Society (AWS), 8669 NW 36 Street, #130, Miami, Florida 33166-6672:
AWS D1.1/D1.1M-2010, *Structural Welding Code – Steel*
AWS D1.3/D1.3M-2008, *Structural Welding Code – Sheet Steel*
6. CSA Group, Mississauga, Ontario, Canada.
CSA S16-09, *Design of Steel Structures*, 2009 Edition including Update No. 1 (2010), Update No. 2 (2010), Update No. 3 (2013)
CSA S136-12, *North American Specification for the Design of Cold-Formed Steel Structural Members*
CSA O325-07 (R2012), *Construction Sheathing*
CSA O121-08 (R2013), *Douglas Fir Plywood*
CSA O151-09 (R2014), *Canadian Softwood Plywood*
CSA W59-13, *Welded Steel Construction (Metal Arc Welding)*
7. Department of Commerce Voluntary Product Standard, administered by NIST, Gaithersburg, MD
DOC PS 1-09, *Structural Plywood*
DOC PS 2-10, *Performance Standard for Wood-Based Structural-Use Panels*
8. National Research Council of Canada, Ottawa, Ontario, Canada
NBCC, *National Building Code of Canada*, 2010 Edition

B. GENERAL DESIGN REQUIREMENTS

B1 General Seismic Design Requirements

B1.1 General

In the U.S. and Mexico, *required strengths* for the *seismic force-resisting system* shall be determined in accordance with the *applicable building code*. Seismic design parameters (R , C_d , Ω_o), *seismic design categories* (SDCs), *risk categories*, *design story drift*, system limitations, and requirements for horizontal and vertical structural irregularities shall also be determined in accordance with the *applicable building code*.

In Canada, effect of *factored load* for the *seismic force-resisting system* shall be determined in accordance with the *applicable building code*. *Seismic force modification factors* (R_d , R_o), *seismic design story drift*, system limitations, and requirements for irregularities shall also be determined in accordance with the *applicable building code*, unless modified herein.

In the absence of an *applicable building code*, the design requirements shall be in accordance with accepted engineering practice for the location under consideration as specified by the applicable sections of ASCE 7, *Minimum Design Loads for Buildings and Other Structures*, in the U.S. and Mexico, or the *National Building Code of Canada* in Canada.

B1.2 Load Path

Seismic load effects shall be resolved through a complete *lateral force-resisting system* using a continuous load path to the foundation.

B1.3 Deformation Compatibility of Members and Connections Not in the Seismic Force-Resisting System

Where deformation compatibility of *structural members* and *connections* that are not part of the *seismic force-resisting system* is required by the *applicable building code*, these elements shall be designed to resist the combination of *gravity load effects* and the effects of deformations occurring at the *design story drift* [*seismic design story drift*] calculated in accordance with the *applicable building code*.

B1.4 Seismic Load Effects Contributed by Masonry and Concrete Walls

Seismic load effects contributed by masonry and concrete walls are permitted to be resisted by the designated *seismic force-resisting systems* of this *Standard* subject to the limitations of Chapter E and Chapter F.

B1.5 Seismic Load Effects From Other Concrete or Masonry Components

Cold-formed steel structural members and *connections* are permitted to resist seismic forces from other concrete or masonry components, including, but not limited to, chimneys, fireplaces, concrete or masonry veneers, and concrete floors or roofs.

B2 Lateral Force-Resisting System

The complete *lateral force-resisting system* shall include one or more designated *seismic force-*

resisting systems, designed in accordance with Chapter E, and all other *components* required to ensure a continuous load path for the *seismic loads*. Combinations of *seismic force-resisting systems* shall be in accordance with the *applicable building code*.

Exception: Substitute components and connections into *approved seismic-force resisting systems* shall meet the requirements of Chapter H.

B3 Design Basis

The *available strength [factored resistance]* of the designated *seismic force-resisting system* shall be greater than or equal to the *required strength [effects of factored loads]* determined from the applicable *load combinations*. To ensure the performance of the designated *seismic force-resisting system*, other *structural members and connections* in the *lateral force-resisting system* that are not part of the *designated energy-dissipating mechanism* shall be designed for the expected strength [probable resistance] of the designated *seismic force-resisting system*, as specified in Chapter E and Chapter F, including the *load effect* determined from the applicable *load combinations*.

User Note:

Within the designated *lateral force-resisting system*, this typically includes the following:

- (a) The *designated energy-dissipating mechanism* is designed and detailed to dissipate energy;
- (b) All other *structural members and connections* permit the necessary energy dissipation to be achieved;
- (c) Structural integrity is maintained;
- (d) *Structural members and connections* in the horizontal and vertical load paths are designed to resist the seismic loads;
- (e) *Diaphragms and collector elements* are capable of transmitting the loads developed at each level to the vertical *seismic force-resisting system*; and
- (f) These *loads* are transmitted to the foundation.

In the U.S. and Mexico, per Section F2.3, the *diaphragm chords and diaphragms* are required to be designed for the *loads* from the *applicable building code* (without consideration of expected strength) and the *collectors* are required to be designed for the expected strength of the *seismic force-resisting system* but need not exceed the seismic *load effect*, including overstrength.

B3.1 Nominal Strength [Resistance]

The *nominal strength [resistance]*, R_n , of the *seismic force-resisting system* shall be determined in accordance with this *Standard*. The *nominal strength [resistance]* of all other *structural members and connections* shall be determined in accordance with the *applicable building code*.

B3.2 Available Strength [Factored Resistance]

The *available strength [factored resistance]* is stipulated as ϕR_n for design in accordance with the provisions for *load and resistance factor design [limit states design]* and R_n/Ω for design in accordance with the provisions for *allowable strength design (ASD)* as designated in Chapter E and Chapter F.

B3.3 Expected Strength [Probable Resistance]

For the *seismic force-resisting system*, the expected strength [probable resistance] shall be determined in accordance with Chapter E.

User Note:

The concept of expected strength [probable resistance] only applies to the *seismic force-resisting system*; i.e., the system that is being utilized to dissipate energy. All other *components* in the *lateral force-resisting system* that are not part of the *seismic force-resisting system* do not utilize their expected strength [probable resistance].

B3.4 Required Strength [Effects of Factored Loads]

For the *seismic force-resisting system*, the *required strength* [effects of *factored loads*] shall be determined in accordance with the *applicable building code*.

In the U.S. and Mexico, for all *structural members* and *connections* in the *lateral force-resisting system* that are not part of the *designated energy-dissipating mechanism*, the *required strength* shall be determined from the expected strength of the *seismic force-resisting system*, but need not exceed the *seismic load effect* including overstrength as designated in Chapter E and Chapter F.

In Canada, for all *structural members* and *connections* in the *lateral force-resisting system*, that are not part of the *designated energy-dissipating mechanism*, the effect of *factored loads* shall be determined from the probable resistance of the *seismic force-resisting system*, but need not exceed the maximum anticipated *seismic load effect* determined with $R_d R_o = 1.0$ as designated in Chapter E and Chapter F.

User Note:

Structural members and *connections* in the *lateral force-resisting system* that are not part of the *designated energy-dissipating mechanism*, as defined for each system in Chapter E, must be designed for force levels that ensure the necessary energy dissipation occurs in the designated mechanism. In the U.S. and Mexico, this is achieved by designing these *components* for the expected force that the designated mechanism delivers into the *components*, or more empirically by amplifying the *seismic load effects* to a sufficiently high level using Ω_o . In Canada, this is achieved by designing these other *structural members* and *connections* for the probable force, which is equivalent to probable resistance of the designated mechanism, but not to force levels higher than those determined from an elastic analysis.

C. ANALYSIS

C1 Seismic Load Effects

An analysis conforming to the requirements of the *applicable building code* and AISI S100 [CSA S136] shall be performed to determine the effect of seismic *load combinations* on the system, except as modified herein.

D. GENERAL MEMBER AND CONNECTION DESIGN REQUIREMENTS

Design of *structural members* and *connections* shall be in accordance with the requirements of Chapters E and F, as appropriate.

E. SEISMIC FORCE-RESISTING SYSTEMS

E1 Cold-Formed Steel Light Frame Shear Walls Sheathed With Wood Structural Panels

E1.1 Scope

Cold-formed steel light frame shear walls sheathed with wood structural panels rated for shear resistance shall be designed in accordance with the requirements of this section.

E1.2 Basis of Design

Cold-formed steel light frame shear walls sheathed with wood structural panels are expected to withstand seismic demands primarily through deformation in the *connection* between the *wood structural panel sheathing* and the *cold-formed steel structural members*.

E1.2.1 Designated Energy-Dissipating Mechanism

The *structural member-to-sheathing connection* and the *wood structural panel sheathing* itself are the *designated energy-dissipating mechanism* in this system.

E1.2.2 Seismic Design Parameters [Seismic Force Modification Factors and Limitations] for Seismic Force-Resisting System

In the U.S. and Mexico, the *seismic response modification coefficient*, R , shall be determined in accordance with the *applicable building code*. For *cold-formed steel light frame shear walls sheathed with wood structural panels* rated for shear resistance, the design shall comply with this section.

User Note:

In the U.S. and Mexico, the *seismic response modification coefficient*, R , is generally determined from ASCE 7, Table 12.2-1. The systems specified here are listed as an $R=6.5$ for bearing wall systems in Table 12.2-1, Line A.16, and $R=7.0$ for building frame systems in Line B.23. To develop the energy dissipation consistent with these *seismic response modification coefficients*, the requirements specified in this section must be followed.

In Canada, the *seismic force modification factors*, R_dR_o , shall be determined in accordance with the *applicable building code*. For *cold-formed steel light frame shear walls with wood-based structural panel sheathing*, the design shall comply with this section.

User Note:

In Canada, the *seismic force modification factors*, R_dR_o , are generally determined from the NBCC. The system specified here is listed as $R_dR_o=4.25$ for screw connected *shear walls with wood-based structural panel sheathing*. To develop the energy dissipation consistent with these factors, the requirements specified in this section must be followed.

E1.2.3 Type I or Type II Shear Walls

The design of *shear walls* that resist seismic loads shall be classified as either *Type I shear walls* or *Type II shear walls* in accordance with this section.

Type I shear walls shall be full-height sheathed with *hold-downs* and anchorage at each end. *Type I shear walls* are permitted to have openings where details are provided to

account for force transfer around openings. Additional requirements are provided in Section E1.3.1.1 and Section E1.4.1.

Type II shear walls are permitted to have openings without specific details to account for force transfer around openings. *Hold-downs* and anchorage at each end of the *Type II shear walls* shall be required. Additional requirements provided in Section E1.3.1.2 and Section E1.4.2 shall be met.

E1.2.4 Seismic Load Effects Contributed by Masonry and Concrete Walls

Cold-formed steel light frame shear walls sheathed with *wood structural panels* are permitted to be used to provide resistance to seismic forces in buildings or *other structures* with masonry or concrete walls, provided the following requirements are met:

- (a) The building or *other structure* is 2 stories or less in height.
- (b) The story-to-story wall heights do not exceed 12 ft (3.66 m).
- (c) *Diaphragms* are considered flexible and do not cantilever beyond the outermost supporting *shear wall*.
- (d) Combined deflections of *diaphragms* and *shear walls* do not permit the *design story drift* of supported masonry or concrete walls to exceed 0.7% of the story height at *LRFD design [LSD factored] load levels*.
- (e) *Wood structural panel* sheathing for both stories of *shear walls* have all unsupported edges blocked and, for the lower story, have a minimum thickness of 15/32" (12 mm).
- (f) There are no horizontal out-of-plane offset irregularities as specified by the *applicable building code*.

E1.3 Shear Strength [Resistance]

E1.3.1 Nominal Strength [Resistance]

E1.3.1.1 Type I Shear Walls

For a *Type I shear wall* sheathed with *wood structural panels*, the *nominal strength [resistance]* for shear, V_n shall be determined in accordance with the following:

For $h/w \leq 2$,

$$V_n = v_n w \quad (\text{Eq. 1.3.1.1-1})$$

where

h = Height of the *shear wall*, ft (m)

w = Length of the *shear wall*, ft (m)

v_n = *Nominal shear strength [resistance]* per unit length for assemblies with *wood structural panel* and *panel blocking* as specified in Table E1.3-1 as lb/ft (kN/m)

Where permitted in Table E1.3-1, the *nominal strength [resistance]* for shear, V_n , for height-to-length aspect ratios ($h:w$) greater than 2:1, but not exceeding 4:1, shall be determined in accordance with the following:

For $2 < h/w \leq 4$,

$$V_n = v_n w (2w/h) \quad (\text{Eq. 1.3.1.1-2})$$

In no case shall the height-to-length aspect ratio ($h:w$) exceed 4:1.

The length of a *Type I shear wall* shall not be less than 24 in. (610 mm).

In the U.S. and Mexico, increases in the *nominal strengths [resistances]* in Table E1.3-1, as allowed by other standards, shall not be permitted.

E1.3.1.1.1 Wall Pier Limitations

The height-to-length aspect ratio ($h_p:w_p$) of a *wall pier* in a *Type I shear wall* with openings shall be limited to a maximum of 2:1.

The length of a *wall pier* (w_p) shall not be less than 24 in. (610 mm).

E1.3.1.1.2 Both Wall Faces Sheathed With the Same Material and Fastener Spacing

For a *Type I shear wall* sheathed with *wood structural panels* having the same material and fastener spacing on opposite faces of the same wall, the *nominal strength [resistance]*, based on Table E1.3-1, shall be determined by adding the strength from the two opposite faces together.

E1.3.1.1.3 More Than a Single Sheathing Material or Fastener Configuration

For a *Type I shear wall* sheathed with *wood structural panels* having more than a single sheathing material or fastener spacing, the *nominal strength [resistance]*, based on Table E1.3-1, of the complete wall shall not be permitted to be determined by adding the *nominal strength [resistance]* from the different individual walls. Rather, it shall be determined in accordance with this section.

For a *Type I shear wall* sheathed with *wood structural panels* having more than a single sheathing material or fastener configuration along one face of the same wall line, the *nominal strength [resistance]* shall be taken either assuming the weaker (lower *nominal strength [resistance]*) material or fastener configuration exists for the entire length of the wall, or the stronger (higher *nominal strength [resistance]*) material or fastener configuration exists for its own length, whichever is greater.

For a *Type I shear wall* sheathed with *wood structural panels* having more than a single sheathing material or fastener configuration on opposite faces of the wall, the *nominal strength [resistance]* shall be taken either assuming the weaker material or fastener configuration exists for both faces of the wall, or the stronger material or fastener configuration exists for its own face alone, whichever is greater.

User Note:

For walls with multiple layers of sheathing on an individual face of a wall, insufficient research exists to provide a definitive solution. Accounting for only the innermost layer when determining the *nominal strength [resistance]* of the panel is assumed to be conservative, but has not been verified by testing.

Table E1.3-1
Nominal Shear Strength [Resistance] (v_n) per Unit Length for Seismic and
Other In-Plane Loads ^{1,4}
For Shear Walls Sheathed With Wood Structural Panels on One Side of Wall

U.S. and Mexico (lb/ft)							
Assembly Description	Max. Aspect Ratio (h:w)	Fastener Spacing at Panel Edges ² (in.)				Designation Thickness ⁵ of Stud and Track (mils)	Minimum Sheathing Screw Size
		6	4	3	2		
15/32" Structural 1 Sheathing (4-ply)	2:1 ³	780	990	-	-	33 or 43	8
	2:1	890	1330	1775	2190	43 or 54	8
		68	10				
7/16" OSB	2:1 ³	700	915	-	-	33	8
	2:1 ³	825	1235	1545	2060	43 or 54	8
	2:1	940	1410	1760	2350	54	8
	2:1	1230	1850	2310	3080	68	10
Canada (kN/m)							
Assembly Description	Max. Aspect Ratio (h:w)	Fastener Spacing at Panel Edges ² (mm)			Designation Thickness ⁵ of Stud and Track (mils)	Required Sheathing Screw Size	
		150	100	75			
9.5 mm CSP Sheathing	2:1 ³	8.5	11.8	14.2	43 (min.)	8	
12.5 mm CSP Sheathing	2:1 ³	9.5	13.0	19.4	43 (min.)	8	
12.5 mm DFP Sheathing	2:1 ³	11.6	17.2	22.1	43 (min.)	8	
9 mm OSB 2R24/W24	2:1 ³	9.6	14.3	18.2	43 (min.)	8	
11 mm OSB 1R24/2F16/W24	2:1 ³	9.9	14.6	18.5	43 (min.)	8	

1. For SI: 1" = 25.4 mm, 1 ft = 0.305 m, 1 lb = 4.45 N. For U.S. Customary Units: 1 mm = 0.0394", 1 m = 3.28 ft, 1 N = 0.225 lb
2. See Section E1.4.1.1 for installation requirements for screws in the field of the panel.
3. See Section E1.3.1.1 for *shear wall* height-to-length aspect ratios (h:w) greater than 2:1, but not exceeding 4:1.
4. See Section E1.3.1.1.2 and Section E1.3.1.1.3 for requirements for sheathing applied to both sides of wall.
5. Only where *Designation Thickness* is specified as a (min) is substitution with a thicker member permitted.

E1.3.1.2 Type II Shear Walls

For a *Type II shear wall*, the *nominal strength [resistance]* for shear, V_n , shall be determined in accordance with the following:

$$V_n = C_a v_n \Sigma L_i \quad (\text{Eq. 1.3.1.2-1})$$

where

C_a = Shear resistance adjustment factor from Table E1.3.1.2-1

For intermediate values of opening height ratio and percentages of full-height sheathing, the shear resistance adjustment factors are permitted to be determined by interpolation.

v_n = *Nominal shear strength [resistance]* per unit length as specified in Table E1.3-1, lb/ft (kN/m)

ΣL_i = Sum of lengths of *Type II shear wall segments*, ft (m)

Table E1.3.1.2-1
Shear Resistance Adjustment Factor- C_a

	Maximum Opening Height Ratio ¹				
	1/3	1/2	2/3	5/6	1
Percent Full-Height Sheathing ²	Shear Resistance Adjustment Factor				
10%	1.00	0.69	0.53	0.43	0.36
20%	1.00	0.71	0.56	0.45	0.38
30%	1.00	0.74	0.59	0.49	0.42
40%	1.00	0.77	0.63	0.53	0.45
50%	1.00	0.80	0.67	0.57	0.50
60%	1.00	0.83	0.71	0.63	0.56
70%	1.00	0.87	0.77	0.69	0.63
80%	1.00	0.91	0.83	0.77	0.71
90%	1.00	0.95	0.91	0.87	0.83
100%	1.00	1.00	1.00	1.00	1.00

1. See Section E1.3.1.2.2.

2. See Section E1.3.1.2.1.

E1.3.1.2.1 Percent Full-Height Sheathing

The percent of full-height sheathing shall be calculated as the sum of lengths (ΣL_i) of *Type II shear wall segments* divided by the total width of the *Type II shear wall* including openings.

E1.3.1.2.2 Maximum Opening Height Ratio

The maximum opening height ratio shall be calculated by dividing the maximum opening clear height by the *shear wall* height, h .

E1.3.2 Available Strength [Factored Resistance]

The *available strength [factored resistance]* ($\phi_v V_n$ for *LRFD* and *LSD* or V_n/Ω_v for *ASD*) shall be determined from the *nominal strength [resistance]* using the applicable *safety factors* and *resistance factors* given in this section in accordance with the applicable design method—*ASD*, *LRFD*, or *LSD* as follows:

$$\begin{aligned}\Omega_v &= 2.50 \quad (ASD) \\ \phi_v &= 0.60 \quad (LRFD) \\ &= 0.70 \quad (LSD)\end{aligned}$$

E1.3.3 Expected Strength [Probable Resistance]

The expected strength [probable resistance] ($\Omega_E V_n$) shall be determined from the *nominal strength [resistance]* in accordance with this section.

In the U.S. and Mexico, the expected strength factor, Ω_E , shall be 1.8 for shear walls sheathed with wood structural panels.

In Canada, the expected strength factor, Ω_E , shall be 1.33 for walls with DFP wood-based structural panel sheathing or OSB wood-based structural panel sheathing, and 1.45 for walls with CSP wood-based structural panel sheathing.

E1.4 System Requirements

E1.4.1 Type I Shear Walls

E1.4.1.1 Limitations for Tabulated Systems

The *Type I shear wall seismic force-resisting system* specified in Table E1.3-1 shall conform to the following requirements:

- (a) Wall *studs* and *track* are ASTM A1003 Structural Grade 33 (Grade 230) Type H steel for members with a *designation thickness* of 33 and 43 mils, and ASTM A1003 Structural Grade 50 (Grade 340) Type H steel for members with a *designation thickness* equal to or greater than 54 mils.
- (b) *Studs* are *C-shape* members with a minimum *flange* width of 1-5/8 in. (41.3 mm), minimum *web* depth of 3-1/2 in. (89 mm) and minimum *edge stiffener* of 3/8 in. (9.5 mm).
- (c) *Track* has a minimum *flange* width of 1-1/4 in. (31.8 mm) and a minimum *web* depth of 3-1/2 in. (89 mm).
- (d) *Chord studs*, or other vertical *boundary elements* at the ends of wall segments braced with sheathing, are anchored such that the bottom *track* is not required to resist uplift by bending of the *track web*.
- (e) Screws for *structural members* are a minimum No. 8 and comply with ASTM C1513.
- (f) Fasteners along the edges in shear panels are placed from panel edges not less than the following, as applicable:
 - (1) In the U.S. and Mexico, 3/8 in. (9.5 mm).
 - (2) In Canada, 12.5 mm (1/2 in.).
- (g) Fasteners in the field of the panel are installed 12 in. (305 mm) o.c. unless otherwise specified.
- (h) Panel thicknesses are taken as minimums.
- (i) Panels less than 12 in. (305 mm) wide are not permitted.
- (j) Maximum *stud* spacing is 24 in. (610 mm) on center.
- (k) All sheathing edges are attached to *structural members* or *panel blocking*.
- (l) Where used as *panel blocking*, flat *strap* is a minimum thickness of 33 mils with a

- minimum width of 1-1/2 in. (38.1 mm) and is installed below the sheathing.
- (m) Where *panel blocking* is used, the screws are installed through the *wood structural panel* sheathing to the *panel blocking*.
 - (n) *Wood structural panel* sheathing is manufactured using exterior glue and complies with the following, as applicable:
 - (1) In the U.S. and Mexico, DOC PS 1 or DOC PS 2.
 - (2) In Canada, CSA-O121, CSA-O151 or CSA-O325.
 - (o) *Wood structural panel* sheathing is permitted to be applied either parallel to or perpendicular to *studs*.
 - (p) *Wood structural panel* sheathing is attached to *cold-formed steel structural members* with either No. 8 self-tapping screws with a minimum head diameter of 0.285 in. (7.24 mm) or No. 10 self-tapping screws with a minimum head diameter of 0.333 in. (8.46 mm).
 - (q) Screws used to attach *wood structural panel* sheathing to *cold-formed steel structural members* comply with ASTM C1513.
 - (r) The pull-out resistance of screws is not used to resist seismic forces.

E1.4.1.2 Required Strength [Effect of Factored Loads] for Chord Studs, Anchorage, and Collectors

In the U.S. and Mexico, for *collectors, chord studs, other vertical boundary elements, hold-downs* and anchorage connected thereto, and all other *components and connections* of the *shear wall* that are not part of the *designated energy-dissipating mechanism*, the *required strength* shall be determined from the expected strength of the *shear wall*, but need not exceed the *load effect* determined from applicable *load* combinations including seismic *load* with overstrength. The *available strength* of the *collectors, chord studs, other vertical boundary members, hold-downs* and anchorage connected thereto, and all other *components and connections* of the *shear wall* shall be greater than or equal to the *required strength*.

In Canada, for *collectors, chord studs, other vertical boundary elements, hold-down* and anchorage connected thereto, and all other *components and connections* of the *lateral force-resisting system* that are not part of the *designated energy-dissipating mechanism*, the effect of *factored loads* shall be determined from the probable resistance of the *seismic force-resisting system*, but need not exceed the maximum anticipated seismic *load effect* determined with $R_d R_o = 1.0$. The *factored resistance* of the *chord studs, other vertical boundary elements, hold-downs* and anchorage connected thereto, and all other *components and connections* in the *lateral force-resisting system* shall be greater than or equal to the effects of *factored loads* determined from the applicable *load* combinations.

E1.4.1.3 Required Strength [Effect of Factored Loads] for Foundations

In the U.S. and Mexico, for foundations, the *required strength* shall be determined from the seismic *load effect* and need not include the overstrength factor (Ω_o) nor consider the expected strength of the *seismic force-resisting system* unless otherwise specified in the *applicable building code*.

In Canada, for foundations in *Type I shear walls*, the effect of *factored loads* shall be determined from the probable resistance of the *seismic force-resisting system*, but need not

exceed the maximum anticipated seismic *load effect* determined with $R_d R_o = 1.0$.

E1.4.1.4 Design Deflection

The deflection of a blocked *cold-formed steel* light frame *shear wall* sheathed with *wood structural panels* is permitted to be calculated in accordance with the following:

$$\delta = \frac{2vh^3}{3EA_c b} + \omega_1 \omega_2 \frac{vh}{\rho G t_{\text{sheathing}}} + \omega_1^{5/4} \omega_2 \omega_3 \omega_4 \left(\frac{v}{\beta} \right)^2 + \frac{h}{b} \delta_v \quad (\text{Eq. E1.4.1.4-1})$$

where

A_c = Gross cross-sectional area of *chord member*, in square in. (mm²)

b = Length of the *shear wall*, in in. (mm)

E = Modulus of elasticity of steel
= 29,500,000 psi (203,000 MPa)

G = Shear modulus of sheathing material, in lb/ in.² (MPa)

h = Wall height, in in. (mm)

s = Maximum fastener spacing at panel edges, in in. (mm)

$t_{\text{sheathing}}$ = Nominal panel thickness, in in. (mm)

t_{stud} = Stud *designation thickness*, in in. (mm)

v = Shear demand, in lb/ in. (N/mm)

$$= V/b$$

(Eq. E1.4.1.4-2)

V = Total lateral *load* applied to the *shear wall*, in lb (N)

β = 67.5 for plywood other than Canadian Softwood Plywood (CSP)

= 55 for OSB and CSP for U.S. Customary Units (lb/in.^{1.5})

= 2.35 for plywood other than CSP

= 1.91 for OSB and CSP for SI units (N/mm^{1.5})

δ = Calculated deflection, in in. (mm)

δ_v = Vertical deformation of anchorage/attachment details, in in. (mm)

ρ = 1.85 for plywood other than CSP, 1.05 for OSB and CSP

ω_1 = $s/6$ (for s in in.) and $s/152.4$ (for s in mm)

(Eq. E1.4.1.4-3)

ω_2 = $0.033/t_{\text{stud}}$ (for t_{stud} in in.)

(Eq. E1.4.1.4-4a)

= $0.838/t_{\text{stud}}$ (for t_{stud} in mm)

(Eq. E1.4.1.4-4b)

ω_3 = $\sqrt{\frac{(h/b)}{2}}$

(Eq. E1.4.1.4-5)

ω_4 = 1 for *wood structural panel sheathing*

E1.4.2 Type II Shear Walls

Type II shear walls shall meet all of the requirements for *Type I shear walls* except where amended by the applicable requirements of Section E1.2.3 and this section.

E1.4.2.1 Additional Limitations

The *Type II shear wall seismic force-resisting system* shall conform to the following

requirements:

- (a) A *Type II shear wall segment*, meeting the aspect ratio (h:w) limitations of Section E1.3.1, is located at each end of a *Type II shear wall*. Openings are permitted to occur beyond the ends of the *Type II shear wall*; however, the length of such openings is not included in the length of the *Type II shear wall*.
- (b) The *nominal strength [resistance]* for shear, V_n , is based upon a screw spacing of not less than 4 in. (100 mm) o.c.
- (c) Where horizontal out-of-plane offset irregularities occur, portions of the wall on each side of the offset are designated as separate *Type II shear walls*.
- (d) *Collectors* for shear transfer are provided for the full length of the *Type II shear wall*.
- (e) A *Type II shear wall* has uniform top-of-wall and bottom-of-wall elevations.
- (f) *Type II shear wall* height, h , does not exceed 20 ft (6.1 m).

User Note:

Type II shear walls not having uniform elevations need to be designed by other methods.

E1.4.2.2 Required Strength [Effect of Factored Loads] for Chord Studs, Anchorage, and Collectors

Design of *collectors* connecting *Type II shear wall segments* and anchorage at the ends or between *Type II shear wall segments* shall conform to the requirements of this section.

E1.4.2.2.1 Collectors Connecting In-Plane Type II Shear Wall Segments

The unit shear force, v , transmitted into the top and out of the base of the *Type II shear wall* full-height sheathing segments, and into *collectors* (drag struts) connecting *Type II shear wall segments*, shall be determined in accordance with the following:

$$v = \frac{V}{C_a \sum L_i} \quad (\text{Eq. E1.4.2.2-1})$$

where

v = Shear force per unit length (plf, kN/m)

V = Shear force in *Type II shear wall* (lb, kN)

In the U.S. and Mexico, V is based on the expected strength of the *Type II shear wall segment*, but need not exceed the seismic load effect including overstrength.

User Note:

For shear walls sheathed with *wood structural panels*, the expected strength is set as the seismic load effect including overstrength as per E1.3.3.

In Canada, V is based on the probable resistance of the *Type II shear wall segment*, but need not exceed the seismic load effect determined with $R_d R_o = 1.0$.

C_a = Shear resistance adjustment factor from Table E1.3.1.2-1

$\sum L_i$ = Sum of lengths of *Type II shear wall segments* (ft, m)

E1.4.2.2.2 Uplift Anchorage and Boundary Chord Forces at Type II Shear Wall Ends

Anchorage for uplift forces due to overturning shall be provided at each end of

the *Type II shear wall*. Uplift anchorage and boundary *chord* forces shall be determined in accordance with the following:

$$C = \frac{Vh}{C_a \sum L_i} \quad (\text{Eq. E1.4.2.2-2})$$

where

C = Boundary *chord* force (tension/compression) (lb, kN)

V = Shear force in *Type II shear wall* (lb, kN)

In the U.S. and Mexico, V is based on the expected strength of the *Type II shear wall segment*, but need not exceed the seismic load effect including overstrength.

In Canada, V is based on the probable resistance of the *Type II shear wall segment*, but need not exceed the seismic load effect determined with $R_d R_o = 1.0$.

h = *Shear wall* height (ft, m)

C_a = Shear resistance adjustment factor from Table E1.3.1.2-1

$\sum L_i$ = Sum of lengths of *Type II shear wall segments* (ft, m)

User Note:

Uplift can be reduced by the dead load and chord forces can be increased by dead load.

E1.4.2.2.3 Uplift Anchorage Between Type II Shear Wall Ends

In addition to the requirements of Section E1.4.2.2.2, *Type II shear wall* bottom plates at full-height sheathing locations shall be anchored for a uniform uplift force equal to the unit shear force, v , determined in accordance with Section E1.4.2.2.1.

E1.4.2.3 Design Deflection

The deflection of a *Type II shear wall* shall be determined by principles of mechanics considering the deformation of the sheathing and its attachment, *chord studs*, *hold-downs* and anchorage.

E2 Cold-Formed Steel Light Frame Shear Walls With Steel Sheet Sheathing

E2.1 Scope

Cold-formed steel light frame *shear walls* with *steel sheet sheathing* shall be designed in accordance with the requirements of this section.

E2.2 Basis of Design

Cold-formed steel light frame *shear walls* with *steel sheet sheathing* are expected to withstand seismic demands primarily through deformation in the *connection* between the *steel sheet sheathing* and *cold-formed steel structural members*.

E2.2.1 Designated Energy-Dissipating Mechanism

The *structural member-to-sheathing connection* and the *steel sheet sheathing* itself are the *designated energy-dissipating mechanism* in this system.

E2.2.2 Seismic Design Parameters [Seismic Force Modification Factors and Limitations] for Seismic Force-Resisting System

In the U.S. and Mexico, the *seismic response modification coefficient*, R , shall be determined in accordance with the *applicable building code*. For *cold-formed steel light frame shear walls with steel sheet sheathing*, the design shall comply with this section.

User Note:

In the U.S. and Mexico, the *seismic response modification coefficient*, R , is generally determined from ASCE 7, Table 12.2-1. The systems specified here are listed as an $R=6.5$ for bearing wall systems in Table 12.2-1, Line A.16, and $R=7.0$ for building frame systems in Line B.23. To develop the energy dissipation consistent with these *seismic response modification coefficients*, the requirements specified in this section must be followed.

In Canada, the *seismic force modification factors*, $R_d R_o$, shall be determined in accordance with Appendix 1. For *cold-formed steel light frame shear walls with steel sheet sheathing*, the design shall comply with this section.

User Note:

In Canada, the *seismic force modification factors*, $R_d R_o$, are generally determined from the NBCC. However, since this is a relatively new system for Canada, the *seismic force modification factors*, $R_d R_o$, and limitations have not yet been adopted by the NBCC. The system specified here is listed as $R_d R_o=2.6$ for screw-connected *shear walls with steel sheet sheathing*. To develop the energy dissipation consistent with these factors, the requirements specified in this section must be followed.

E2.2.3 Type I or Type II Shear Walls

The design of *shear walls* that resist seismic loads shall be classified as either *Type I shear walls* or *Type II shear walls* in accordance with this section.

Type I shear walls shall be full-height sheathed with *hold-downs* and anchorage at each end. *Type I shear walls* are permitted to have openings where details are provided to account for force transfer around openings. Additional requirements are provided in Section E2.3.1.1 and Section E2.4.1.

Type II shear walls are permitted to have openings without specific details to account for force transfer around openings. *Hold-downs* and anchorage at each end of the *Type II shear walls* shall be required. Additional requirements provided in Section E2.3.1.2 and Section E2.4.2 shall be met.

E2.2.4 Seismic Load Effects Contributed by Masonry and Concrete Walls

Cold-formed steel light frame shear walls with steel sheet sheathing are permitted to be used to provide resistance to seismic forces in buildings and *other structures* with masonry or concrete walls, provided the following requirements are met:

- (a) The building or *other structure* is 2 stories or less in height.
- (b) The story-to-story wall heights do not exceed 12 ft (3.66 m).
- (c) *Diaphragms* are considered flexible and do not cantilever beyond the outermost supporting *shear wall*.
- (d) Combined deflections of *diaphragms* and *shear walls* do not permit per story drift of

supported masonry or concrete walls to exceed 0.7% of the story height at *LRF design [LSD factored]* load levels.

- (e) *Steel sheet sheathing* for both stories of *shear walls* have all unsupported edges blocked and, for the lower story, have a minimum thickness of 0.027" (0.683 mm).
- (f) There are no horizontal out-of-plane offset irregularities as specified by the *applicable building code*.

E2.3 Shear Strength [Resistance]

E2.3.1 Nominal Strength [Resistance]

E2.3.1.1 Type I Shear Walls

For a *Type I shear wall* with *steel sheet sheathing*, the *nominal strength [resistance]* for shear, V_n , shall be determined in accordance with the following:

For $h/w \leq 2$,

$$V_n = v_n w \quad (\text{Eq. E2.3.1.1-1})$$

where

h = Height of the *shear wall*, ft (m)

w = Length of the *shear wall*, ft (m)

v_n = *Nominal shear strength [resistance]* per unit length for assemblies with *steel sheet sheathing* and *panel blocking* as specified in Table E2.3-1 lb/ft (kN/m) or determined in accordance with Section E2.3.1.1.1

Where permitted in Table E2.3-1 or Section E2.3.1.1.1, the *nominal strength [resistance]* for shear, V_n , for height-to-length aspect ratios ($h:w$) greater than 2:1, but not exceeding 4:1, shall be determined in accordance with the following:

For $2 < h/w \leq 4$,

$$V_n = v_n w (2w/h) \quad (\text{Eq. E2.3.1.1-2})$$

In no case shall the height-to-length aspect ratio ($h:w$) exceed 4:1.

The length of a *Type I shear wall* shall not be less than 24 in. (610 mm).

E2.3.1.1.1 Effective Strip Method

The effective strip method is permitted to be used only in the United States and Mexico. The *nominal shear strength [resistance]* per unit length for a *Type I shear wall* with *steel sheet sheathing*, which meets the limitations specified in Section E2.3.1.1.1.1, is permitted to be determined in accordance with the effective strip method as follows:

$$V_n = \text{minimum}(1.33P_n \cos \alpha, 1.33w_e t F_y \cos \alpha) \quad (\text{Eq. E2.3.1.1.1-1})$$

where

P_n = *Nominal shear strength [resistance]* of screw connections within the effective strip width, W_e , on the steel sheet sheathing

α = $\text{Arctan}(h/w)$ (Eq. E2.3.1.1.1-2)

h = *Shear wall* height

w = *Shear wall* length

t = Design thickness of steel sheet sheathing

$$F_y = \text{Yield stress of steel sheet sheathing}$$

$$w_e = w_{\max}, \text{ when } \lambda \leq 0.0819 \quad (\text{Eq. E2.3.1.1.1-3})$$

$$= \rho w_{\max}, \text{ when } \lambda > 0.0819 \quad (\text{Eq. E2.3.1.1.1-4})$$

where

$$w_{\max} = w/\sin\alpha \quad (\text{Eq. E2.3.1.1.1-5})$$

$$\rho = \frac{1 - 0.55(\lambda - 0.08)^{0.12}}{\lambda^{0.12}} \quad (\text{Eq. E2.3.1.1.1-6})$$

$$\lambda = 1.736 \frac{\alpha_1 \alpha_2}{\beta_1 \beta_2 \beta_3^2 a} \quad (\text{Eq. E2.3.1.1.1-7})$$

where

$$\alpha_1 = F_{\text{ush}}/45 \quad (\text{For } F_{\text{ush}} \text{ in ksi}) \quad (\text{Eq. E2.3.1.1.1-8})$$

$$= F_{\text{ush}}/310.3 \quad (\text{For } F_{\text{ush}} \text{ in MPa}) \quad (\text{Eq. E2.3.1.1.1-9})$$

$$\alpha_2 = F_{\text{uf}}/45 \quad (\text{For } F_{\text{uf}} \text{ in ksi}) \quad (\text{Eq. E2.3.1.1.1-10})$$

$$= F_{\text{uf}}/310.3 \quad (\text{For } F_{\text{uf}} \text{ in MPa}) \quad (\text{Eq. E2.3.1.1.1-11})$$

$$\beta_1 = t_{\text{sh}}/0.018 \quad (\text{For } t_{\text{sh}} \text{ in in.}) \quad (\text{Eq. E2.3.1.1.1-12})$$

$$= t_{\text{sh}}/0.457 \quad (\text{For } t_{\text{sh}} \text{ in mm}) \quad (\text{Eq. E2.3.1.1.1-13})$$

$$\beta_2 = t_f/0.018 \quad (\text{For } t_f \text{ in in.}) \quad (\text{Eq. E2.3.1.1.1-14})$$

$$= t_f/0.457 \quad (\text{For } t_f \text{ in mm}) \quad (\text{Eq. E2.3.1.1.1-15})$$

$$\beta_3 = s/6 \quad (\text{For } s \text{ in in.}) \quad (\text{Eq. E2.3.1.1.1-16})$$

$$= s/152.4 \quad (\text{For } s \text{ in mm}) \quad (\text{Eq. E2.3.1.1.1-17})$$

F_{ush} = Tensile strength of steel sheet sheathing

F_{uf} = Minimum tensile strength of framing materials

T_{sh} = Design thickness of steel sheet sheathing

T_f = Minimum design thicknesses of framing members

s = Screw spacing on the panel edges

a = Wall aspect ratio (h:w)

$$= h/w \quad (\text{Eq. E2.3.1.1.1-18})$$

E2.3.1.1.1.1 The effective strip method is permitted to be used within the following range of parameters:

- (a) Designation thickness of stud, track, and stud blocking: 33 mils (0.838 mm) to 54 mils (1.37 mm).
- (b) Designation thickness of steel sheet sheathing: 18 mils (0.457 mm) to 33 mils (0.838 mm).
- (c) Screw spacing at panel edges: 2 in. (50.8 mm) to 6 in. (152 mm).
- (d) Height-to-length aspect ratio (h:w): 1:1 to 4:1.
- (e) Sheathing screw shall be minimum No. 8.
- (f) Yield stress of steel sheet sheathing shall not be greater than 50 ksi (345 MPa).

See Section E2.3.1.1 for *Type I shear wall* height-to-length aspect ratios (h:w) greater than 2:1, but not exceeding 4:1 for additional requirements.

E2.3.1.1.2 Wall Pier Limitations

The height-to-length aspect ratio ($h_p:w_p$) of a wall pier in a *Type I shear wall* with

openings shall be limited to a maximum of 2:1.

The length of a *wall pier* (w_p) shall not be less than 24 in. (610 mm).

E2.3.1.1.3 Both Wall Faces Sheathed With the Same Material and Fastener Spacing

For a *Type I shear wall with steel sheet sheathing* having the same material and fastener spacing on opposite faces of the same wall, the *nominal strength [resistance]*, based on Table E2.3-1, shall be determined by adding the strength from the two opposite faces together.

E2.3.1.1.4 More Than a Single Sheathing Material or Fastener Configuration

For a *Type I shear wall with steel sheet sheathing* having more than a single sheathing material or fastener spacing, the *nominal strength [resistance]*, based on Table E2.3-1 or Section E2.3.1.1.1, of the complete wall shall not be permitted to be determined by adding the strength from the different individual walls. Rather, it shall be determined in accordance with this section.

For a *Type I shear wall with steel sheet sheathing* having more than a single sheathing material or fastener configuration along one face of the same wall line, the *nominal strength [resistance]* shall be taken either assuming the weaker (lower *nominal strength [resistance]*) material or fastener configuration exists for the entire length of the wall, or the stronger (higher *nominal strength [resistance]*) material or fastener configuration exists for its own length, whichever is greater.

For a *Type I shear wall with steel sheet sheathing* having more than a single sheathing material or fastener configuration on opposite faces of the wall, the *nominal strength [resistance]* shall be taken either assuming the weaker material or fastener configuration exists for both faces of the wall, or the stronger material or fastener configuration exists for its own face alone, whichever is greater.

User Note:

For walls with multiple layers of sheathing on an individual face of a wall, insufficient research exists to provide a definitive solution. Accounting for only the innermost layer when determining the *strength [resistance]* of the panel is assumed to be conservative, but has not been verified by testing.

Table E2.3-1
Nominal Shear Strength [Resistance] (v_n) per Unit Length for Seismic and Other In-Plane Loads ^{1,4}
for Shear Walls With Steel Sheet Sheathing on One Side of Wall

<i>U.S. and Mexico</i> (lb/ft)								
Assembly Description	Max. Aspect Ratio (h:w)	Fastener Spacing at Panel Edges ² (in.)				Stud Blocking Required	Designation Thickness ⁵ of Stud, Track and Stud Blocking (mils)	Minimum Sheathing Screw Size
		6	4	3	2			
0.018" steel sheet	2:1	390	-	-	-	No	33 (min.)	8
0.027" steel sheet	2:1 ³	-	1000	1085	1170	No	43 (min.)	8
	2:1 ³	647	710	778	845	No	33 (min.)	8
0.030" steel sheet	2:1 ³	910	1015	1040	1070	No	43 (min.)	8
	2:1 ³	-	-	-	1355	Yes	43 (min.)	10
0.033" steel sheet	2:1 ³	1055	1170	1235	1305	No	43 (min.)	8
	2:1 ³	-	-	-	1505	Yes	43 (min.)	10
	2:1 ³	-	-	-	1870	No	54 (min.)	8
	2:1 ³	-	-	-	2085	Yes	54 (min.)	10
<i>Canada</i> (kN/m)								
Assembly Description	Max. Aspect Ratio (h:w)	Fastener Spacing at Panel Edges ² (mm)				Stud Blocking Required	Designation Thickness ⁵ of Stud, Track and Stud Blocking (mils)	Required Sheathing Screw Size
		150	100	75	50			
0.46 mm steel sheet	2:1	4.1	---	---	---	No	33 (min)	8
0.46 mm steel sheet	2:1	4.5	6.0	6.8	7.5	No	43 (min)	8
0.68 mm steel sheet	2:1	6.5	7.2	7.9	8.7	No	33 (min)	8
0.76 mm steel sheet	4:1	8.9	10.6	11.6	12.5	No	43 (min)	8
0.84 mm steel sheet	4:1	10.7	12.0	13.0	14.0	No	43 (min)	8
0.46 mm steel sheet	2:1	7.4	9.7	11.6	13.5	Yes	43 (min)	8
0.76 mm steel sheet	2:1	11.7	14.3	---	---	Yes	43 (min)	8
0.76 mm steel sheet	2:1	---	---	19.9	23.3	Yes	54 (min)	8

1. F or SI: 1" = 25.4 mm, 1 ft = 0.305 m, 1 lb = 4.45 N. For U.S. Customary Units: 1 mm = 0.0394", 1 m = 3.28 ft, 1 N = 0.225 lb
2. See Section E2.4.1.1 for installation requirements for screws in the field of the panel.
3. See Section E2.3.1.1 for *shear wall* height to length aspect ratios (h:w) greater than 2:1, but not exceeding 4:1.
4. See Section E2.3.1.1.2 and Section E2.3.1.1.3 for requirements for sheathing applied to both sides of wall.
5. Only where *Designation Thickness* is specified as a (min) is substitution with a thicker member permitted.

E2.3.1.2 Type II Shear Walls

For a *Type II shear wall*, the *nominal strength [resistance]* for shear, V_n , shall be determined in accordance with the following:

$$V_n = C_a v_n \Sigma L_i \quad (\text{Eq. 2.3.1.2-1})$$

where

C_a = Shear resistance adjustment factor from Table E2.3.1.2-1

For intermediate values of opening height ratio and percentages of full-height sheathing, the shear resistance adjustment factors are permitted to be determined by interpolation.

v_n = *Nominal shear strength [resistance]* per unit length as specified in Table E2.3-1, lb/ft (kN/m)

ΣL_i = Sum of lengths of *Type II shear wall segments*, ft (m)

Table E2.3.1.2-1
Shear Resistance Adjustment Factor- C_a

	Maximum Opening Height Ratio ¹				
	1/3	1/2	2/3	5/6	1
Percent Full-Height Sheathing ²	Shear Resistance Adjustment Factor				
10%	1.00	0.69	0.53	0.43	0.36
20%	1.00	0.71	0.56	0.45	0.38
30%	1.00	0.74	0.59	0.49	0.42
40%	1.00	0.77	0.63	0.53	0.45
50%	1.00	0.80	0.67	0.57	0.50
60%	1.00	0.83	0.71	0.63	0.56
70%	1.00	0.87	0.77	0.69	0.63
80%	1.00	0.91	0.83	0.77	0.71
90%	1.00	0.95	0.91	0.87	0.83
100%	1.00	1.00	1.00	1.00	1.00

1. See Section E2.3.1.2.2.

2. See Section E2.3.1.2.1.

E2.3.1.2.1 Percent Full-Height Sheathing

The percent of full-height sheathing shall be calculated as the sum of lengths (ΣL_i) of *Type II shear wall segments* divided by the total length of the *Type II shear wall* including openings.

E2.3.1.2.2 Maximum Opening Height Ratio

The maximum opening height ratio shall be calculated by dividing the maximum opening clear height by the *shear wall* height, h .

E2.3.2 Available Strength [Factored Resistance]

The *available strength [factored resistance]* ($\phi_v V_n$ for *LRFD* and *LSD* or V_n/Ω_v for *ASD*) shall be determined from the *nominal strength [resistance]* using the applicable *safety factors* and *resistance factors* given in this section in accordance with the applicable design method—*ASD*, *LRFD*, or *LSD* as follows:

$$\begin{aligned}\Omega_v &= 2.50 \quad (ASD) \\ \phi_v &= 0.60 \quad (LRFD) \\ &= 0.70 \quad (LSD)\end{aligned}$$

E2.3.3 Expected Strength [Probable Resistance]

The expected strength [probable resistance] ($\Omega_E V_n$) shall be determined from the *nominal strength [resistance]* in accordance with this section.

In the U.S. and Mexico, the expected strength factor, Ω_E , shall be 1.8 for shear walls with steel sheet sheathing.

In Canada, the expected strength factor, Ω_E , shall be 1.4 for walls with *steel sheet sheathing*.

E2.4 System Requirements

E2.4.1 Type I Shear Walls

E2.4.1.1 Limitations for Tabulated Systems

The *Type I shear wall seismic force-resisting system* specified in Table E2.3-1 shall conform to the following requirements:

- (a) Wall *studs* and *track* are ASTM A1003 Structural Grade 33 (Grade 230) Type H steel for members with a *designation thickness* of 33 and 43 mils, and ASTM A1003 Structural Grade 50 (Grade 340) Type H steel for members with a *designation thickness* equal to or greater than 54 mils.
- (b) *Studs* are *C-shape* members with a minimum *flange* width of 1-5/8 in. (41.3 mm), minimum *web* depth of 3-1/2 in. (89 mm) and minimum *edge stiffener* of 3/8 in. (9.5 mm).
- (c) *Track* has a minimum *flange* width of 1-1/4 in. (31.8 mm) and a minimum *web* depth of 3-1/2 in. (89 mm).
- (d) *Chord studs*, or other vertical *boundary elements* at the ends of wall segments braced with sheathing, are anchored such that the bottom *track* is not required to resist uplift by bending of the *track web*.
- (e) Screws for *structural members* are a minimum No. 8 and comply with ASTM C1513.
- (f) Fasteners along the edges in shear panels are placed from panel edges not less than the following, as applicable:
 - (1) In the U.S. and Mexico, 3/8 in. (9.5 mm).
 - (2) In Canada, 12.5 mm (1/2 in.).
- (g) Fasteners in the field of the panel are installed 12 in. (305 mm) o.c. unless otherwise specified.
- (h) Panel thicknesses are taken as minimums.
- (i) Panels less than 12-in. (305-mm) wide are not permitted.
- (j) Maximum *stud* spacing is 24 in. (610 mm) on center.
- (k) All sheathing edges are attached to *structural members* or *panel blocking*.
- (l) In lieu of *panel blocking*, unblocked assemblies with panel edges are permitted to be overlapped and attached to each other with screw spacing as required for panel

- edges. Where such a connection is used, the *nominal strength [resistance]* provided in Table E2.3-1 is to be multiplied by 0.70.
- (m) Where used as *panel blocking*, *flat strap* is a minimum thickness of 33 mils with a minimum width of 1-1/2 in. (38.1 mm) and is installed either on top of or below the sheathing.
 - (n) *Steel sheet sheathing* has a minimum *base steel thickness* as specified in Table E2.3-1 and complies with ASTM A1003 Structural Grade 33 (Grade 230) Type H.
 - (o) In Canada, *steel sheet sheathing* shall be connected without horizontal joints.
 - (p) Where *shear walls* require multiple vertical sheathing panels, a single *stud* shall be used at the sheathing joint, unless the connection between the combined *studs* is designed for the shear transfer between panels.
 - (q) Screws used to attach *steel sheet sheathing* comply with ASTM C1513.
 - (r) *Stud blocking* is installed at quarter-points for all *shear wall* heights and meets either of the following requirements:
 - (1) In-line block-and-strap method: In-line *blocking* is a *stud* or *track* section with the same *web* depth and minimum thickness as the *studs*. Flat *straps* have a minimum thickness of 33 mils with a minimum width of 1-1/2 in. (38.1 mm). In-line *blocking* is installed between *studs* at the termination of all flat *straps*, at 12 ft (3.66 m) intervals along the flat *strap*, and at the ends of the shear wall. Flat *straps* are attached to the *flanges* of each *stud* with a minimum of one No. 8 screw and to the *flanges* of the in-line *blocking* with a minimum of two No. 8 screws. In-line *blocking* is attached to each *stud* with a minimum of one No. 8 screw.
 - (2) Solid-block method: In-line *blocking* is a *stud* or *track* section with the same *web* depth and minimum thickness as the *studs*. In-line *blocking* is installed between every *stud*. In-line *blocking* is attached to each *stud* with a minimum of one No. 8 screw.
 - (s) The pull-out resistance of screws is not used to resist seismic forces.

E2.4.1.2 Required Strength [Effect of Factored Loads] for Chord Studs, Anchorage, and Collectors

In the U.S. and Mexico, for *collectors*, *chord studs*, other vertical *boundary elements*, *hold-downs* and anchorage connected thereto, and all other *components* and *connections* of the *shear wall* that are not part of the *designated energy-dissipating mechanism*, the *required strength* shall be determined from the expected strength of the *shear wall*, but need not exceed the *load effect* determined from applicable *load* combinations including seismic loads with overstrength. The *available strength* of the *collectors*, *chord studs*, other vertical *boundary elements*, *hold-downs* and anchorage connected thereto, and all other *components* and *connections* of the *shear wall* shall be greater than or equal to the *required strength*.

In Canada, for *collectors*, *chord studs*, other vertical *boundary elements*, *hold-downs* and uplift anchorage connected thereto, and all other *components* and *connections* in the *lateral force-resisting system* that are not part of the *designated energy-dissipating mechanism*, the effect of *factored loads* shall be determined from the probable resistance of the *seismic force-resisting system*, but need not exceed the maximum anticipated seismic *load effect* determined with $R_d R_o = 1.0$. The *factored resistance* of the *collectors*, *chord studs*, other vertical *boundary elements*, *hold-downs* and anchorage connected thereto, *collectors*, and all

other *components* and *connections* of the *lateral force-resisting system* shall be greater than or equal to the effects of *factored loads* determined from the applicable *load combinations*.

E2.4.1.3 Required Strength [Effect of Factored Loads] for Foundations

In the U.S. and Mexico, for foundations, the *required strength* shall be determined from the *seismic load effect* and need not include the overstrength factor (Ω_o) nor consider the expected strength of the *seismic force-resisting system* unless otherwise specified in the *applicable building code*.

In Canada, for foundations in *Type I shear walls*, the effect of *factored loads* shall be determined from the probable resistance of the *seismic force-resisting system*, but need not exceed the maximum anticipated *seismic load effect* determined with $R_d R_o = 1.0$.

E2.4.1.4 Design Deflection

The deflection of a blocked *cold-formed steel light frame Type I shear wall* with *steel sheet sheathing* is permitted to be calculated in accordance with the following:

$$\delta = \frac{2vh^3}{3EA_c b} + \omega_1 \omega_2 \frac{vh}{\rho G t_{\text{sheathing}}} + \omega_1^{5/4} \omega_2 \omega_3 \omega_4 \left(\frac{v}{\beta} \right)^2 + \frac{h}{b} \delta_v \quad (\text{Eq. E2.4.1.4-1})$$

where

A_c = Gross cross-sectional area of *chord member*, in square in. (mm²)

b = Length of the *shear wall*, in in. (mm)

E = Modulus of elasticity of steel
= 29,500,000 psi (203,000 MPa)

G = Shear modulus of sheathing material, in lb/ in.²(MPa)

h = Wall height, in in. (mm)

s = Maximum fastener spacing at panel edges, in in. (mm)

$t_{\text{sheathing}}$ = Nominal panel thickness, in in. (mm)

t_{stud} = Stud *designation thickness*, in in. (mm)

v = Shear demand, in lb/ in. (N/mm)

$$= V/b$$

(Eq. E2.4.1.4-2)

V = Total lateral *load* applied to the *shear wall*, in lb (N)

β = 29.12 × ($t_{\text{sheathing}}/0.018$) for steel sheet (for $t_{\text{sheathing}}$ in in.) (lb/in^{1.5})

(Eq. E2.4.1.4-3a)

$$= 1.01 \times (t_{\text{sheathing}}/0.457) \quad \text{for steel sheet (for } t_{\text{sheathing}} \text{ in mm) (N/mm}^{1.5}\text{)}$$

(Eq. E2.4.1.4-3b)

δ = Calculated deflection, in in. (mm)

δ_v = Vertical deformation of anchorage/attachment details, in in. (mm)

ρ = 0.075 × ($t_{\text{sheathing}}/0.018$) for steel sheet (for $t_{\text{sheathing}}$ in in.)

(Eq. E2.4.1.4-4a)

$$= 0.075 \times (t_{\text{sheathing}}/0.457) \quad \text{for steel sheet (for } t_{\text{sheathing}} \text{ in mm)}$$

(Eq. E2.4.1.4-4b)

ω_1 = $s/6$ (for s in in.) and $s/152.4$ (for s in mm)

(Eq. E2.4.1.4-5)

$$\omega_2 = 0.033/t_{\text{stud}} \text{ (for } t_{\text{stud}} \text{ in in.)} \quad (\text{Eq. E2.4.1.4-6a})$$

$$= 0.838/t_{\text{stud}} \text{ (for } t_{\text{stud}} \text{ in mm)} \quad (\text{Eq. E2.4.1.4-6b})$$

$$\omega_3 = \sqrt{\frac{(h/b)}{2}} \quad (\text{Eq. E2.4.1.4-7})$$

$$\omega_4 = \sqrt{\frac{33}{F_y}} \text{ (for } F_y \text{ in ksi)} \quad (\text{Eq. E2.4.1.4-8a})$$

$$= \sqrt{\frac{227.5}{F_y}} \text{ (for } F_y \text{ in MPa) for steel sheet} \quad (\text{Eq. E2.4.1.4-8b})$$

E2.4.2 Type II Shear Walls

Type II shear walls shall meet all of the requirements for *Type I shear walls* except where amended by the applicable requirements of Section E2.2.3 and this section.

E2.4.2.1 Additional Limitations

The *Type II shear wall seismic force-resisting system* shall conform to the following requirements:

- (a) A *Type II shear wall segment*, meeting the aspect ratio (h:w) limitations of Section E2.3.1, is located at each end of a *Type II shear wall*. Openings are permitted to occur beyond the ends of the *Type II shear wall*; however, the length of such openings is not included in the length of the *Type II shear wall*.
- (b) The *nominal strength [resistance]* for shear, V_n , is based upon a screw spacing of not less than 4 in. (100 mm) o.c.
- (c) Where horizontal out-of-plane offset irregularities occur, portions of the wall on each side of the offset are designated as separate *Type II shear walls*.
- (d) *Collectors* for shear transfer are provided for the full length of the *Type II shear wall*.
- (e) A *Type II shear wall* has uniform top-of-wall and bottom-of-wall elevations.
- (f) *Type II shear wall* height, h , does not exceed 20 ft (6.1 m).

User Note:

Type II shear walls not having uniform elevations need to be designed by other methods.

E2.4.2.2 Required Strength [Effects of Factored Loads] for Chord Studs, Anchorage, and Collectors

Design of *collectors* connecting *Type II shear wall segments* and anchorage at the ends or between *Type II shear wall segments* shall conform to the requirements of this section, or shall be determined using principles of mechanics.

E2.4.2.2.1 Collectors Connecting In-Plane Type II Shear Wall Segments

The unit shear force, v , transmitted into the top and out of the base of the *Type II shear wall* full-height sheathing segments, and into *collectors* (drag struts) connecting *Type II shear wall segments*, shall be determined in accordance with the following:

$$v = \frac{V}{C_a \sum L_i} \quad (\text{Eq. E2.4.2.2-1})$$

where

v = Shear force per unit length (plf, kN/m)

V = Shear force in *Type II shear wall* (lb, kN)

In the U.S. and Mexico, V is based on the expected strength of the *shear wall* segment, but need not exceed the seismic load effect including overstrength.

User Note:

For shear walls with *steel sheet sheathing*, the expected strength is set as the seismic load effect including overstrength as per Section E2.3.3.

In Canada, V is based on the probable resistance of the *shear wall* segment, but need not exceed the seismic load effect determined with $R_d R_o = 1.0$.

C_a = Shear resistance adjustment factor from Table E2.3.1.2-1

ΣL_i = Sum of lengths of *Type II shear wall segments* (ft, m)

E2.4.2.2.2 Uplift Anchorage and Boundary Chord Forces at Type II Shear Wall Ends

Anchorage for uplift forces due to overturning shall be provided at each end of the *Type II shear wall*. Uplift anchorage and boundary *chord* forces shall be determined in accordance with the following:

$$C = \frac{Vh}{C_a \Sigma L_i} \quad (\text{Eq. E2.4.2.2-2})$$

where

C = Boundary *chord* force (tension/compression) (lb, kN)

V = Shear force in *Type II shear wall* (lb, kN)

In the U.S. and Mexico, V is based on the expected strength of the *shear wall* segment, but need not exceed the seismic load effect including overstrength.

In Canada, V is based on the probable resistance of the *shear wall* segment, but need not exceed the seismic load effect determined with $R_d R_o = 1.0$.

h = *Shear wall* height (ft, m)

C_a = Shear resistance adjustment factor from Table E2.3.1.2-1

ΣL_i = Sum of lengths of *Type II shear wall segments* (ft, m)

User Note:

Uplift can be reduced by the dead load and *chord* forces can be increased by dead load.

E2.4.2.2.3 Uplift Anchorage Between Type II Shear Wall Ends

In addition to the requirements of Section E2.4.2.2.2, *Type II shear wall* bottom plates at full-height sheathing locations shall be anchored for a uniform uplift force equal to the unit shear force, v , determined in accordance with Section E2.4.2.2.1.

E2.4.2.3 Design Deflection

The deflection of a *Type II shear wall* shall be determined by principles of mechanics considering the deformation of the sheathing and its attachment, *chord studs*, *hold-downs* and anchorage.

E3 Cold-Formed Steel Light Frame Strap Braced Wall Systems

E3.1 Scope

Cold-formed steel light frame strap braced wall systems shall be designed in accordance with the requirements of this section.

E3.2 Basis of Design

Cold-formed steel light frame strap braced wall systems are expected to withstand seismic demands primarily through tension yielding along the length of the *strap bracing*.

E3.2.1 Designated Energy-Dissipating Mechanism

Yielding of the *strap bracing* is the *designated energy-dissipating mechanism*.

E3.2.2 Seismic Design Parameters [Seismic Force Modification Factors and Limitations] for Seismic Force-Resisting System

In the U.S. and Mexico, the *seismic response modification coefficient*, R , shall be determined in accordance with the *applicable building code*. For *cold-formed steel light frame strap braced wall* systems, the design shall comply with this section.

User Note:

In the U.S. and Mexico, the *seismic response modification coefficient*, R , is generally determined from ASCE 7, Table 12.2-1. The systems specified here are listed as an $R=4$ for bearing wall systems in Table 12.2-1, Line A.18. To develop the energy dissipation consistent with this *seismic response modification coefficient*, the requirements specified in this section must be followed.

In Canada, the *seismic force modification factors*, $R_d R_o$, shall be determined in accordance with the *applicable building code*. For *cold-formed steel light frame strap braced wall* systems, the design shall comply with this section.

User Note:

In Canada, the *seismic force modification factors*, $R_d R_o$, are generally determined from the NBCC. The system specified here is listed as $R_d R_o=2.47$ for limited ductility of *strap braced walls*. To develop the energy dissipation consistent with these factors, the requirements specified in this section must be followed.

E3.2.3 Seismic Load Effects Contributed by Masonry and Concrete Walls

Cold-formed steel light frame strap braced wall systems are permitted to be used to provide resistance to seismic forces in buildings and *other structures* with masonry or concrete walls, provided the following requirements are met:

- (a) The building or *other structure* is 2 stories or less in height.
- (b) The story-to-story wall heights do not exceed 12 ft (3.66 m).
- (c) *Diaphragms* are considered flexible and do not cantilever beyond the outermost supporting *strap braced wall*.
- (d) Combined deflections of *diaphragms* and walls do not permit per story drift of supported masonry or concrete walls to exceed 0.7% of the story height at *LRFD design [LSD factored] load* levels.
- (e) There are no horizontal out-of-plane offset irregularities as specified by the *applicable building code*.

E3.3 Shear Strength [Resistance]

E3.3.1 Nominal Strength [Resistance]

For a *strap braced wall*, the wall *nominal strength [resistance]* for shear, V_n , shall be determined in accordance with the following:

$$V_n = T_n w / \sqrt{h^2 + w^2} \quad (\text{Eq. E3.3.1-1})$$

where

h = Height of the wall

w = Length of the wall

T_n = *Nominal strength [resistance]* of the *strap braced wall* in yielding

$$= A_g F_y \quad (\text{Eq. E3.3.1-2})$$

A_g = Gross area of the flat *strap*

F_y = Yield stress of the flat *strap*

User Note:

Users are reminded that the *designated energy-dissipating mechanism* is *strap yielding*; other traditional tension limit states such as net section fracture are addressed in Section E3.4.

E3.3.2 Available Strength [Factored Resistance]

The *available strength [factored resistance]* ($\phi_v V_n$ for *LRFD* and *LSD* or V_n/Ω_v for *ASD*) shall be determined from the *nominal strength [resistance]* using the applicable *safety factors* and *resistance factors* given in this section in accordance with the applicable design method – *ASD*, *LRFD*, or *LSD* as follows:

$$\Omega_v = 1.67 \quad (\text{ASD})$$

$$\phi_v = 0.90 \quad (\text{LRFD})$$

$$= 0.90 \quad (\text{LSD})$$

E3.3.3 Expected Strength [Probable Resistance]

The expected strength [probable resistance] shall be $R_y A_g F_y$ where A_g is the gross area of the *strap bracing*.

E3.4 System Requirements

E3.4.1 Limitations on System

The *cold-formed steel light frame strap braced wall* system shall conform to the following requirements:

(a) The *connection* of the *strap bracing* member to the *structural members* is designed in accordance with one of the following three methods:

(1) Method 1: The *connection* is welded and configured such that gross cross-section yielding of the *strap bracing* member governs its strength.

(2) Method 2: The *connection* is configured such that the *strap bracing* member meets both of the following criteria:

$$(R_t F_u) / (R_y F_y) \geq 1.2 \quad (\text{Eq. E3.4.1-1})$$

and,

$$R_t A_n F_u > R_y A_g F_y \quad (\text{Eq. E3.4.1-2})$$

User Note:

Compliance can be demonstrated using published values or through coupon testing. If coupon testing is conducted to determine values, then R_t and R_y become 1.0.

- (3) Method 3: The *connection* is configured such that gross cross-section yielding of the *strap bracing* member under cyclic loading is demonstrated by tests in accordance with the loading protocol in ASTM E2126.
- (b) For *strap braced walls* where the aspect ratio ($h:w$) exceeds 1.9:1:
- (1) A lateral frame analysis of the *strap braced wall* is required to be performed. The frame analysis is to be based on the assumption of full *joint* fixity.

User Note:

Commentary Section E3.4.1 provides expressions for a frame analysis with full *joint* fixity. The purpose of the frame analysis is to determine the moment demand on the *chord studs*.

- (2) In considering the moment along the length of the *chord stud*, locations that are stiffened by a *hold-down* or similar attachment at the ends need not be checked for combined axial load and bending.

User Note:

From the frame analysis, the *chord stud* is designed for combined axial load and bending at the *expected strength* [*probable resistance*] of the *strap braced wall*, in combination with all other applicable loads, in accordance with Section E3.4.2.

- (c) Provisions are made for pretensioning, or other methods of installing tension-only *strap bracing* to guard against loose *strap bracing*.
- (d) *Chord studs*, or other vertical *boundary elements* at the ends of wall segments with *strap bracing*, are anchored such that the bottom *track* is not required to resist uplift by bending of the *track web*. Where the *track* is not designed to resist the horizontal shear force from the *strap bracing* by compression or tension, the horizontal shear force is resisted by a device connected directly to the *strap bracing* and anchored directly to the foundation or supporting structural element.

E3.4.2 Required Strength [Effect Due to Factored Loads] for Seismic Force-Resisting System

In the U.S. and Mexico, for *collectors*, *connections* of *strap bracing*, *chord studs*, other vertical *boundary elements*, *hold-downs* and anchorage connected thereto, and all other *components* and *connections* of the *strap braced wall*, the *required strength* shall be determined from the expected strength of the *strap braced wall*, but need not exceed the *load effect* determined from the applicable *load* combinations including seismic loads with overstrength. The *available strength* of the *collectors*, *connections* of *strap bracing*, *chord studs*, other vertical *boundary elements*, *hold-downs* and anchorage connected thereto, and all other *components* and *connections* in the *strap braced wall* shall be greater than or equal to the *required strength*.

In Canada, for *collectors*, *connections* of *strap bracing*, *chord studs*, other vertical *boundary elements*, *hold-downs* and anchorage connected thereto, and all other *components* and *connections* in the *lateral force-resisting system*, the effect of *factored loads* shall be determined from the probable resistance of the *strap braced wall* taking into consideration the applicable load combinations, but need not exceed the anticipated maximum seismic *load effects*

determined with $R_dR_o=1.0$. The *factored resistance* of the *collectors, connections of strap bracing, chord studs, other vertical boundary elements, hold-downs* and anchorage connected thereto, and all other *components and connections* of the *lateral force-resisting system* shall be greater than or equal to the effect of *factored loads* determined from the applicable *load combinations*.

The effect of *eccentricity on required strengths* [effect due to *factored loads*] for *connections, chord studs, hold-downs* and anchorage shall be considered in the design.

E3.4.3 Required Strength [Effect Due to Factored Loads] for Foundations

In the U.S. and Mexico, for foundations, the *required strength* shall be determined from the *seismic load effect* and need not include the *overstrength factor* (Ω_o) nor consider the expected strength of the *seismic force-resisting system* unless otherwise specified in the *applicable building code*.

In Canada, for foundations, the effect of *factored loads* shall be determined from the probable resistance of the *seismic force-resisting system*, but need not exceed the maximum anticipated *seismic load effect* determined with $R_dR_o=1.0$.

E3.4.4 Design Deflection

The deflection of a *strap braced wall* shall be determined by principles of mechanics considering the deformation of the *strap, chord studs, hold-downs* and anchorage.

E4 Cold-Formed Steel Special Bolted Moment Frames (CFS-SBMF)

E4.1 Scope

In the U.S. and Mexico, *Cold-Formed Steel-Special Bolted Moment Frame (CFS-SBMF)* systems shall be designed in accordance with this section. This *Standard* does not have provisions for this system that are applicable in Canada.

E4.2 Basis of Design

Cold-Formed Steel-Special Bolted Moment Frame (CFS-SBMF) systems are expected to withstand *inelastic friction and bearing deformations* at the bolted *beam-to-column connections*.

E4.2.1 Designated Energy-Dissipating Mechanism

The *designated energy-dissipating mechanism* is the *beam-to-column connection*.

E4.2.2 Seismic Design Parameters for Seismic Force-Resisting System

In the U.S. and Mexico, the *seismic response modification coefficient*, R , shall be determined in accordance with the *applicable building code*. For *cold-formed steel special bolted moment frames*, the design shall comply with this section.

User Note:

In the U.S. and Mexico, the *seismic response modification coefficient*, R , is generally determined from ASCE 7, Table 12.2-1. The systems specified here are listed as an $R=3.5$ for moment-resisting frame systems in Table 12.2-1, Line C.12. To develop the energy dissipation consistent with this *seismic response modification coefficient*, the requirements specified in this section must be followed.

E4.2.3 Seismic Load Effects Contributed by Masonry and Concrete Walls

Seismic load effects contributed by masonry and concrete walls shall not be permitted to be resisted by *cold-formed steel special bolted moment frames*.

E4.3 Strength

The *nominal strength* for shear shall be determined in accordance with AISI S100.

Where required to determine the *nominal strength* for shear, for limit states within the same member from which the *required strength* is determined, the expected yield stress, $R_e R_{cf} R_y F_y$, and the expected tensile strength, $R_t F_u$ are permitted to be used in lieu of F_y and F_u , respectively, where F_u is the *specified minimum tensile strength* and R_t is the ratio of the expected tensile strength to the *specified minimum tensile strength*, F_u of that material.

E4.3.1 Required Strength

The *required strength* for shear of the *connection* shall be based on the *LRFD load combinations* in the *applicable building code* using the *seismic load effect* including overstrength. In determining the *seismic load effect* including overstrength, the effect of horizontal seismic forces including overstrength, E_{mh} , shall be taken as stipulated by Sections E4.3.1.1 and E4.3.1.2. The horizontal *seismic load effect* including overstrength need not exceed $\Omega_o E_h$.

E4.3.1.1 Beams and Columns

The *required strength* of beams and columns in CFS-SBMF systems shall be determined from the expected moment developed at the bolted *connection*. The expected shear, V_e , shall be determined in accordance with Section E4.3.3.

E4.3.1.2 Bolt Bearing Plates

Bolt bearing plates shall be welded to the beam *web* and be designed for the following *required shear strength*, V_{bp} :

$$V_{bp} = \frac{V_e}{N} \left(\frac{t_p}{t_w + t_p} \right) \quad (\text{Eq. E4.3.1.2-1})$$

where

t_p = Thickness of bolt bearing plate

t_w = Thickness of beam *web*

V_e = Expected strength of the bolted *connection*, as determined in Section E4.3.3

N = 1 for single-channel beams

= 2 for double-channel beams

E4.3.2 Available Strength

The *available strength* for shear shall be determined from the *nominal strength* using the applicable *resistance factors* given in AISI S100 in accordance with the *LRFD load combinations*.

E4.3.3 Expected Strength

The expected shear strength, V_e , shall be determined as follows:

$$V_e = V_S + V_B \quad (\text{Eq. E4.3.3-1})$$

where

V_S = Column shear corresponding to the slip strength of the bolt group

V_B = Connection bearing component of column shear corresponding to the displacement, Δ

(1) Slip Component of Column Shear, V_S

The value of V_S shall be determined as follows:

$$V_S = C_S k N T / h \quad (\text{Eq. E4.3.3-2})$$

where

C_S = Value from Table E4.3.3-1

k = Slip coefficient
= 0.33

N = 1 for single-channel beams
= 2 for double-channel beams

T = 10 kips (44.5 kN) for 1-in. (25.4-mm) diameter bolts, unless the use of a higher value is *approved*

h = Height from column base to center line of beam

(2) Bearing Component of Column Shear, V_B

The value of V_B shall be determined as follows:

$$\left(\frac{V_B}{V_{B,\max}} \right)^2 + \left(1 - \frac{\Delta_B}{\Delta_{B,\max}} \right)^{1.43} = 1 \quad (\text{Eq. E4.3.3-3})$$

where

$V_{B,\max}$ = Column shear producing the bearing strength of a bolt group
= $C_B N R_0 / h$ (Eq. E4.3.3-4)

Δ = *Design story drift*

Δ_B = Component of *design story drift* causing bearing deformation in a bolt group

$$= \Delta - \Delta_s - \frac{\sum_{i=1}^n \left(\frac{M_{e,i}}{h_i} \right)}{K} \geq 0 \quad (\text{Eq. E4.3.3-5})$$

$\Delta_{B,\max}$ = Component of *design story drift* corresponding to the deformation of the bolt group at maximum bearing strength
= $C_{B,0} C_{DB} h$ (Eq. E4.3.3-6)

Δ_s = Component of *design story drift* corresponding to bolt slip deformation
= $C_{DS} h_{os} h$ (Eq. E4.3.3-7)

C_B , C_{DS} , and $C_{B,0}$ = Values from Table E4.3.3-1

C_{DB} = Value from Table E4.3.3-2

- d = Bolt diameter
- h_{os} = Hole oversize
- K = Elastic lateral stiffness of the frame line
- M_e = Expected moment at a bolt group
- n = Number of columns in a frame line
- R_0 = Smallest value of dR_tF_u of connected *components*
- F_u = Tensile strength of connected component
- t = Thickness of connected *component*
- R_t = Ratio of expected tensile strength to *specified minimum tensile strength*

Alternate methods of calculating V_S and V_B are permitted if such methods are acceptable to the *authority having jurisdiction*.

Table E4.3.3-1
Values of Coefficients C_S , C_{DS} , C_B , and $C_{B,0}$

Bolt spacing, in.			C_S (ft)	C_{DS} (1/ft)	C_B (ft)	$C_{B,0}$ (in./ft)
a	b	c				
2½	3	4¼	2.37	5.22	4.20	0.887
3	6		3.34	3.61	5.88	0.625
3	10		4.53	2.55	7.80	0.475
2½	3	6¼	2.84	4.66	5.10	0.792
3	6		3.69	3.44	6.56	0.587
3	10		4.80	2.58	8.50	0.455

Table E4.3.3-2
Bearing Deformation Adjustment Factor C_{DB}

Relative Bearing Strength, R_{BS}	0.0	0.4	0.5	0.6	0.7	0.8	0.9	1.0
C_{DB}	1.00	1.10	1.16	1.23	1.33	1.46	1.66	2.00

where

Relative Bearing Strength (R_{BS}) = $(tF_u)_{(weaker)} / (tF_u)_{(stronger)}$, where weaker *components* correspond to that with a smaller tF_u value.

t = Thickness of beam or column *component*

F_u = Tensile strength of beam or column

E4.4 System Requirements

The *Cold-Formed Steel*-Special Bolted Moment Frame (CFS-SBMF) systems shall conform to the requirements in this section.

E4.4.1 Limitations on System

The *Cold-Formed Steel*-Special Bolted Moment Frames (CFS-SBMF) systems shall conform to the following requirements:

- (a) CFS-SBMF systems are limited to one-story structures, no greater than 35 ft (10.7 m) in height, without column splices.
- (b) The CFS-SBMF engages all columns.
- (c) All columns shall be designed and constructed as pin-based.
- (d) A single size and length beam and single size and length column with the same bolted moment *connection* detail are used for each frame.
- (e) The frame is supported on a level floor or foundation.
- (f) For structures having a period shorter than T_S , as defined in the *applicable building code*, alternate methods of computing the *design story drift*, Δ , are permitted, provided such methods are acceptable to the *authority having jurisdiction*.
- (g) P- Δ effects are considered in accordance with the requirements of the *applicable building code*.

E4.4.2 Beams

Beams in the *Cold-Formed Steel*-Special Bolted Moment Frames (CFS-SBMF) system shall conform to the following requirements:

- (a) Beams in CFS-SBMF systems are ASTM A653 Grade 55 galvanized *cold-formed steel* C-section members with lips, designed in accordance with Chapter C of AISI S100.
- (b) The beams have a minimum design thickness of 0.105 in. (2.67 mm).
- (c) The beam depth is not less than 12 in. (305 mm) or greater than 20 in. (508 mm).
- (d) The flat depth-to-thickness ratio of the *web* does not exceed $6.18\sqrt{E/F_y}$.
- (e) Where single C-section beams are used, torsional effects are accounted for in the design.

E4.4.3 Columns

Columns in the *Cold-Formed Steel*-Special Bolted Moment Frames (CFS-SBMF) system shall conform to the following requirements:

- (a) Columns in CFS-SBMF systems are *cold-formed steel* hollow structural section (HSS) members painted with a standard industrial finished surface, and designed in accordance with Chapter C of AISI S100. Hollow structural section (HSS) columns are permitted to be ASTM A500 Grade B and C, and ASTM A1085 materials.
- (b) The column depth and width are not less than 8 in. (203 mm) or greater than 12 in. (305 mm).
- (c) The flat depth-to-thickness ratio does not exceed $1.40\sqrt{E/F_y}$.

E4.4.4 Connections, Joints and Fasteners

Connections, joints and fasteners that are part of the *seismic force-resisting system* shall meet the requirements of AISI S100 except as modified in this section.

Connections for members that are a part of the *seismic force-resisting system* shall be configured such that a ductile limit-state in the member or at the *joint* controls the design.

E4.4.4.1 Bolted Joints

Bolts shall be high-strength bolts, and bolted *joints* shall not be designed to share *load* in combination with welds.

The bearing strength of bolted *joints* shall be provided using standard holes or short-slotted holes perpendicular to the line of force, unless an alternative hole-type is specified by a *registered design professional*.

E4.4.4.1.1 Beam-to-Column Connections

Beam-to-column *connections* in the *Cold-Formed Steel-Special Bolted Moment Frame (CFS-SBMF)* systems shall conform to the following requirements:

- (a) Beam-to-column *connections* in CFS-SBMF systems are bolted *connections* with 1-in. (25.4-mm) diameter *snug-tightened* high-strength bolts.
- (b) The bolt spacing and edge distance are in accordance with the limits of Section E3 of AISI S100.
- (c) The 8-bolt configuration in Table E4.3.1-1 is used.
- (d) The faying surfaces of the beam and column in the bolted moment *connection* region are free of lubricants or debris.

E4.4.4.1.2 Bolt Bearing Plates

Bolt bearing plates in the *Cold-Formed Steel-Special Bolted Moment Frame (CFS-SBMF)* systems shall conform to the following requirements:

- (a) The use of bolt bearing plates on beam *webs* in CFS-SBMF systems are permitted to increase the bearing strength of the bolt.
- (b) Bolt bearing plates are welded to the beam *web*.
- (c) The edge distance of bolts are in accordance with the limits of Section E3 of AISI S100.

E4.4.4.2 Welded Joints

Welded *joints* are permitted to join members that are a part of the *seismic force-resisting system*, in accordance with AISI S100.

E4.4.4.3 Other Joints and Connections

Alternative *joints* and *connections* are permitted if the *registered design professional* demonstrates performance equivalent to the *approved joints* and *connections* specified in accordance with Chapter H.

E5 Cold-Formed Steel Light Frame Shear Walls With Wood-Based Structural Panel Sheathing on One Side and Gypsum Board Panel Sheathing on the Other Side

E5.1 Scope

In Canada, *cold-formed steel* light frame *shear walls* sheathed with wood-based structural panels on one side and gypsum board panels on the other side shall be designed in accordance with the requirements of this section. This *Standard* does not have provisions for this system that are applicable in the U.S. and Mexico.

E5.2 Basis of Design

Cold-formed steel light frame *shear walls* sheathed with wood-based structural panels on one side and gypsum board panels on the other side are expected to withstand seismic demands primarily through deformation in the *connections* between both the wood-based structural panel and gypsum board panel and *cold-formed steel structural members*.

E5.2.1 Designated Energy-Dissipating Mechanism

The structural member-to-sheathing *connection* and the wood-based structural panel and gypsum board panel themselves are the *designated energy-dissipating mechanism* in this system.

E5.2.2 Seismic Force Modification Factors and Limitations for Seismic Force-Resisting System

The *seismic force modification factors*, R_dR_o , shall be determined in accordance with the *applicable building code*. For *cold-formed steel* light frame *shear walls* sheathed with wood-based structural panels on one side and gypsum board panels on the other side, the design shall comply with this section.

User Note:

In Canada, the *seismic force modification factors*, R_dR_o , are generally determined from the NBCC. The system specified here is listed as $R_dR_o=2.55$ for screw-connected *shear walls* with wood-based structural panel sheathing on one side and gypsum panels on the other side. To develop the energy dissipation consistent with these factors, the detailing specified in this section must be followed.

For this *seismic force-resisting system*, gypsum board panel *shear walls* shall not be used alone to resist lateral loads and the use of gypsum board panels in *shear walls* shall be limited to structures four stories or less in height, in accordance with the *applicable building code*. (See Appendix 1 for details.)

E5.2.3 Type I Shear Walls

The design of *shear walls* that resist seismic loads shall be classified as *Type I shear walls* in accordance with this section.

Type I shear walls shall be full-height sheathed with *hold-downs* and anchorage at each end.

E5.2.4 Seismic Load Effects Contributed by Masonry and Concrete Walls

Cold-formed steel light frame *shear walls* sheathed with wood-based structural panels on

one side and gypsum panels on the other side shall not be used to provide resistance to seismic forces from masonry or concrete walls.

E5.3 Shear Resistance

E5.3.1 Nominal Resistance

E5.3.1.1 Type I Shear Walls

For a *Type I shear wall* sheathed with wood-based structural panels on one side and gypsum board panels on the other side, the *nominal resistance* for shear, V_n , shall be determined in accordance with the following:

For $h/w \leq 2$,

$$V_n = v_n w \quad (\text{Eq. E5.3.1.1-1})$$

where

h = Height of the *shear wall*, ft (m)

w = Length of the *shear wall*, ft (m)

v_n = Nominal shear resistance per unit length as specified in Table E1.3-1 lb/ft (kN/m) and Table E5.3-1 and as determined in accordance with Section E5.3.1.1.2, as applicable

The length of a *Type I shear wall* shall not be less than 24 in. (610 mm).

E5.3.1.1.1 Both Wall Faces Sheathed With the Same Material and Fastener Spacing

For a *Type I shear wall* sheathed with wood-based structural panels on one side and gypsum board panels on the other side having the same material and fastener spacing on opposite faces of the same wall, the *nominal resistance*, based on Table E1.3-1 and Table E5.3-1, shall be determined by adding the strength from the two opposite faces together.

Table E5.3-1
Canada

Nominal Shear Resistance (v_n) per Unit Length for Seismic Loads for Shear Walls Sheathed With Gypsum Board on One Side of Wall^{1,2,3} (kN/m)

Assembly Description	Maximum Aspect Ratio (h:w)	Fastener Spacing at Panel Edges/Field (mm)			Designation Thickness of Stud and Track (mils)	Required Sheathing Screw Size
		100/300	150/300	200/300		
12.5 mm gypsum board; studs max. 600 mm o.c.	2:1	3.4	3.1	2.7	33 (min.)	6

1. For U.S. Customary Units: 1 mm = 0.0394", 1 m = 3.28 ft, 1 N = 0.225 lb
2. Only where *Designation Thickness* is specified as a (min) is substitution with a thicker member permitted.
3. Tabulated values are applicable for short-term *load* duration only (seismic loads). Gypsum-sheathed *shear walls* are not permitted for other *load* durations.

E5.3.2 Factored Resistance

The *factored resistance* ($\phi_v V_n$) shall be determined from the *nominal resistance* using the applicable *resistance factor* given in this section in accordance with LSD as follows:

$$\phi_v = 0.70 \text{ (LSD)}$$

E5.3.3 Probable Resistance

The probable resistance ($\Omega_E V_n$) shall be determined from the *nominal resistance* in accordance with this section. The expected resistance factor, Ω_E , shall be 1.33 for walls with DFP wood-based structural panel sheathing, OSB wood-based structural panel sheathing, or gypsum board panel sheathing; and 1.45 for walls with CSP wood-based structural panel sheathing.

E5.4 System Requirements

E5.4.1 Type I Shear Walls

E5.4.1.1 Limitations for Tabulated Systems

The *Type I shear wall seismic force-resisting system* specified in Table E1.3-1 and Table E5.3-1 shall conform to the following requirements:

- (a) Wall *studs* and *track* are ASTM A1003 Structural Grade 33 (Grade 230) Type H steel for members with a *designation thickness* of 33 and 43 mils, and ASTM A1003 Structural Grade 50 (Grade 340) Type H steel for members with a *designation thickness* equal to or greater than 54 mils.
- (b) *Studs* are *C-shape* members with a minimum *flange* width of 1-5/8 in. (41.3 mm), minimum *web* depth of 3-1/2 in. (89 mm) and minimum *edge stiffener* of 3/8 in. (9.5 mm).
- (c) *Track* has a minimum *flange* width of 1-1/4 in. (31.8 mm) and a minimum *web* depth of 3-1/2 in. (89 mm).
- (d) *Chord studs*, or other vertical *boundary elements* at the ends of wall segments braced with sheathing, are anchored such that the bottom *track* is not required to resist uplift by bending of the *track web*.
- (e) Screws for *structural members* are a minimum No. 8 and comply with ASTM C1513.
- (f) Fasteners along the edges in shear panels are placed from panel edges not less than 12.5 mm (1/2 in.).
- (g) Fasteners in the field of the panel are installed 12 in. (305 mm) o.c. unless otherwise specified.
- (h) Panel thicknesses are taken as minimums.
- (i) Panels less than 12-in. (305-mm) wide are not permitted.
- (j) Maximum *stud* spacing is 24 in. (610 mm) on center.
- (k) All sheathing edges are attached to *structural members* or *panel blocking*.
- (l) Where used as *panel blocking*, flat *strap* is a minimum thickness of 33 mils with a minimum width of 1-1/2 in. (38.1 mm) and is installed below the sheathing.
- (m) Where *panel blocking* is used, the screws are installed through the *wood structural panel* sheathing to the *panel blocking*.
- (n) *Wood structural panel* sheathing is manufactured using exterior glue and complies with CSA-O121, CSA-O151 or CSA-O325.
- (o) *Wood structural panel* sheathing is permitted to be applied either parallel to or perpendicular to *studs*.
- (p) *Wood structural panel* sheathing is attached to *cold-formed steel structural members* with either No. 8 self-tapping screws with a minimum head diameter of 0.285 in. (7.24

- mm) or No. 10 self-tapping screws with a minimum head diameter of 0.333 in. (8.46 mm).
- (q) Screws used to attach *wood structural panel* sheathing to *cold-formed steel structural members* comply with ASTM C1513.
 - (r) The pull-out resistance of screws is not used to resist seismic forces.
 - (s) Gypsum board panels comply with ASTM C1396/C1396M.
 - (t) For gypsum board panels that are applied perpendicular to *studs*, flat *strap* is used as *panel blocking* behind the horizontal *joint* with in-line *blocking* between the first two end *studs*, at each end of the wall. In-line *blocking* is a *stud* or *track* section with the same *web* depth and minimum thickness as the *studs*. In-line *blocking* is attached to each *stud* with a minimum of one No. 8 screw. For gypsum board panels that are applied parallel to *studs*, all panel edges are attached to *structural members*. Unblocked assemblies are permitted provided the *nominal resistance* values are multiplied by 0.35.
 - (u) Screws used to attach gypsum board panels shall be in accordance with ASTM C954 or ASTM C1002, as applicable.

E5.4.1.2 Effect of Factored Loads for Chord Studs, Anchorage, and Collectors

For *chord studs*, other vertical *boundary elements*, uplift anchorage connected thereto, *collectors*, and all other *components* and *connections* in the *lateral force-resisting system* that are not part of the *designated energy-dissipating mechanism*, the effect of *factored loads* shall be determined from the probable resistance of the *seismic force-resisting system*, but need not exceed the maximum anticipated seismic *load effect* determined with $R_d R_o = 1.0$. The *factored resistance* of the *chord studs*, other vertical *boundary elements*, and uplift anchorage connected thereto, *collectors*, and all other *components* and *connections* in the *lateral force-resisting system* shall be greater than or equal to the effects of *factored loads* determined from the applicable *load combinations*.

E5.4.1.3 Effect of Factored Loads for Foundations

For foundations in *Type I shear walls*, the effect of *factored loads* shall be determined from the probable resistance of the *seismic force-resisting system*, but need not exceed the maximum anticipated seismic *load effect* determined with $R_d R_o = 1.0$.

E5.4.1.4 Design Deflection

The deflection of a *Type I shear wall* shall be determined by principles of mechanics considering the deformation of the sheathing and its attachment, *chord studs*, *hold-downs* and anchorage.

E6 Cold-Formed Steel Light Frame Shear Walls With Gypsum Board or Fiberboard Panel Sheathing

E6.1 Scope

In the U.S. and Mexico, *cold-formed steel light frame shear walls* sheathed with gypsum board panels or *fiberboard* panels shall be designed in accordance with this section. This *Standard* does not have provisions for this system that are applicable in Canada.

E6.2 Basis of Design

Cold-formed steel light frame shear walls sheathed with gypsum board panels or *fiberboard* panels are expected to withstand seismic demands primarily through deformation in the *connection* between the sheathing and *cold-formed steel structural members*.

E6.2.1 Designated Energy-Dissipating Mechanism

The structural member-to-sheathing *connection* and the sheathing itself are the *designated energy-dissipating mechanism* in this system.

E6.2.2 Seismic Design Parameters for Seismic Force-Resisting System

The *seismic response modification coefficient*, R , shall be determined in accordance with the *applicable building code*. For *cold-formed steel light frame shear walls* sheathed with gypsum board panels or *fiberboard* panels, the design shall comply with this section.

User Note:

In the U.S. and Mexico, the *seismic response modification coefficient*, R , is generally determined from ASCE 7, Table 12.2-1. The systems specified here are listed as an $R=2.0$ for bearing wall systems in Table 12.2-1, Line A.17, and $R=2.5$ for building frame systems in Line B.24. To develop the energy dissipation consistent with these *seismic response modification coefficients* the detailing specified in this section must be followed.

E6.2.3 Type I Shear Walls

The design of *shear walls* that resist seismic *loads* shall be classified as *Type I shear walls* in accordance with this section.

Type I shear walls shall be full-height sheathed with *hold-downs* and anchorage at each end.

E6.2.4 Seismic Load Effects Contributed by Masonry and Concrete Walls

Cold-formed steel light frame shear walls sheathed with gypsum board panels or *fiberboard* panels shall not be used to provide resistance to seismic forces from masonry or concrete walls.

E6.3 Shear Strength

E6.3.1 Nominal Strength

E6.3.1.1 Type I Shear Walls

For a *Type I shear wall* sheathed with gypsum board panels or *fiberboard* panels, the *nominal strength* for shear, V_n shall be determined in accordance with the following:

For $h/w \leq 2$,

$$V_n = v_n w \quad (\text{Eq. E6.3.1.1-1})$$

where

h = Height of the *shear wall*, ft (m)

w = Length of the *shear wall*, ft (m)

v_n = *Nominal shear strength* per unit length as specified in Table E6.3-1 lb/ft (kN/m)

In no case shall the height-to-length aspect ratio ($h:w$) exceed 2:1 for a *Type I shear wall* sheathed with gypsum board panels or 1:1 for a *Type I shear wall* sheathed with *fiberboard* panels.

The length of a *Type I shear wall* shall not be less than 24 in. (610 mm).

E6.3.1.1.1 Both Wall Faces Sheathed With the Same Material and Fastener Spacing

For a *Type I shear wall* sheathed with gypsum board panels or *fiberboard* panels having the same material and fastener spacing on opposite faces of the same wall, the *nominal strength*, based on Table E6.3-1, shall be determined by adding the strength from the two opposite faces together.

E6.3.1.1.2 More Than a Single Sheathing Material or Fastener Configuration

For a *Type I shear wall* sheathed with gypsum board panels or *fiberboard* panels having more than a single sheathing material or fastener spacing, the *nominal strength*, based on Table E6.3-1, of the complete wall shall not be permitted to be determined by adding the strength from the different walls. Rather, it shall be determined in accordance with this section.

For a *Type I shear wall* sheathed with gypsum board panels or *fiberboard* panels having more than a single sheathing material or fastener configuration along one face of the same wall line, the *nominal strength* shall be taken either assuming the weaker (lower *nominal strength*) material or fastener configuration exists for the entire length of the wall, or the stronger (higher *nominal strength*) material or fastener configuration exists for its own length, whichever is greater.

For a *Type I shear wall* sheathed with gypsum board panels or *fiberboard* panels having more than a single sheathing material or fastener configuration on opposite faces of the wall, the *nominal strength* shall be taken either assuming the weaker material or fastener configuration exists for both faces of the wall, or the stronger material or fastener configuration exists for its own face alone, whichever is greater.

User Note:

For walls with multiple layers of sheathing on an individual face of a wall, insufficient research exists to provide a definitive solution. Accounting for only the innermost layer when determining the strength of the panel is assumed to be conservative, but has not been verified by testing.

Table E6.3-1
U.S. and Mexico
Nominal Shear Strength (v_n) per Unit Length for Seismic Loads for Shear Walls
Sheathed with Gypsum Board Panels or Fiberboard Panels on One Side of Wall^{1,2,3} (lb/ft)

Assembly Description	Maximum Aspect Ratio (h:w)	Fastener Spacing at Panel Edges/Field (in.)							Designation Thickness of Stud and Track (mils)	Required Sheathing Screw Size
		7/7	4/4	4/12	8/12	4/6	3/6	2/6		
½" gypsum board; studs max. 24" o.c.	2:1	290	425	295	230	-	-	-	33	6
½" fiberboard; studs max. 24" o.c.	1:1	-	-	-	-	425	615	670	33	8

1. For SI: 1" = 25.4 mm, 1 ft = 0.305 m, 1 lb = 4.45 N

2. See Section E6.3.1.1.1 and Section E6.3.1.1.2 for requirements for sheathing applied to both sides of wall.

3. For gypsum board or fiberboard sheathed shear walls, tabulated values are applicable for short-term load duration only (seismic loads).

E6.3.2 Available Strength

The available strength ($\phi_v V_n$ for LRFD or V_n/Ω_v for ASD) shall be determined from the nominal strength using the applicable safety factors and resistance factors given in this section in accordance with the applicable design method – ASD or LRFD as follows:

$$\Omega_v = 2.50 \quad (\text{ASD})$$

$$\phi_v = 0.60 \quad (\text{LRFD})$$

E6.3.3 Expected Strength

The expected strength ($\Omega_E V_n$) shall be determined from the nominal strength in accordance with this section. The expected strength factor, Ω_E , shall be equal to 1.5 for shear walls with gypsum board or fiberboard panel sheathing.

E6.4 System Requirements

E6.4.1 Type I Shear Walls

E6.4.1.1 Limitations for Tabulated Systems

The Type I shear wall seismic force-resisting system specified in Table E6.3-1 shall conform to the following requirements:

- (a) Wall studs and track are ASTM A1003 Structural Grade 33 (Grade 230) Type H steel for members with a designation thickness of 33 and 43 mils, and ASTM A1003 Structural Grade 50 (Grade 340) Type H steel for members with a designation thickness equal to or greater than 54 mils.
- (b) Studs are C-shape members with a minimum flange width of 1-5/8 in. (41.3 mm), minimum web depth of 3-1/2 in. (89 mm) and minimum edge stiffener of 3/8 in. (9.5 mm).
- (c) Track has a minimum flange width of 1-1/4 in. (31.8 mm) and a minimum web depth of 3-1/2 in. (89 mm).
- (d) Chord studs, or other vertical boundary elements at the ends of wall segments braced

- with sheathing, are anchored such that the bottom *track* is not required to resist uplift by bending of the *track web*.
- (e) Screws for *structural members* are a minimum No. 8 and comply with ASTM C1513.
 - (f) Fasteners along the edges in shear panels are placed from panel edges not less than 3/8 in. (9.5 mm).
 - (g) Fasteners in the field of the panel are installed 12 in. (305 mm) o.c. unless otherwise specified.
 - (h) Panel thicknesses are taken as minimums.
 - (i) Panels less than 12-in. (305-mm) wide are not permitted.
 - (j) Maximum *stud* spacing is 24 in. (610 mm) on center.
 - (k) All sheathing edges are attached to *structural members* or *panel blocking*.
 - (l) Where used as *panel blocking*, flat *strap* is a minimum thickness of 33 mils with a minimum width of 1-1/2 in. (38.1 mm) and is installed below the sheathing.
 - (m) Gypsum board panels comply with ASTM C1396/C1396M.
 - (n) For gypsum board panels that are applied perpendicular to *studs*, flat *strap* is used as *panel blocking* behind the horizontal *joint* with in-line *blocking* between the first two end *studs*, at each end of the wall. In-line *blocking* is a *stud* or *track* section with the same *web* depth and minimum thickness as the *studs*. In-line *blocking* is attached to each *stud* with a minimum of one No. 8 screw. For gypsum board panels that are applied parallel to *studs*, all panel edges are attached to *structural members*. Unblocked assemblies are permitted provided the *nominal resistance* values are multiplied by 0.35.
 - (o) Screws used to attach gypsum board panels are in accordance with ASTM C954 or ASTM C1002, as applicable.
 - (p) *Fiberboard* panels comply with ASTM C208.
 - (q) For *fiberboard* panels that are applied perpendicular to *studs*, flat *strap* is used as *panel blocking* behind the horizontal *joint* and with in-line *blocking* between the first two end *studs*, at each end of the wall. In-line *blocking* is a *stud* or *track* section with the same *web* depth and minimum thickness as the *studs*. In-line *blocking* is attached to each *stud* with a minimum of one No. 8 screw. For *fiberboard* panels applied parallel to *studs*, all edges are attached to *structural members*.
 - (r) Screws used to attach *fiberboard* panels comply with ASTM C1513. Head style is selected to provide a flat bearing surface in contact with the sheathing with a head diameter not less than 0.43 in. (10.9 mm). Screws are to be driven so that their flat bearing surface is flush with the surface of the sheathing.
 - (s) The pull-out resistance of screws is not used to resist seismic forces.

E6.4.1.2 Required Strength for Chord Studs, Anchorage, and Collectors

For *collectors*, *chord studs*, other vertical *boundary elements*, *hold-downs* and anchorage connected thereto, and all other *components* and *connection* of the *shear wall* that are not part of the *designated energy-dissipating mechanism*, the *required strength* shall be determined from the expected strength of the *shear wall*, but need not exceed the *load effect* determined from applicable *load* combinations including seismic *load* with overstrength. The *available strength* of the *collectors*, *chord studs*, other vertical *boundary*

elements, hold-downs and anchorage connected thereto, and all other components and connections in the shear wall shall be greater than or equal to the required strength.

E6.4.1.3 Required Strength for Foundations

For foundations, the *required strength* shall be determined from the seismic load effect and need not include the overstrength factor (Ω_o) nor consider the expected strength of the *seismic force-resisting system* unless otherwise specified in the *applicable building code*.

E6.4.1.4 Design Deflection

The deflection of a *Type I shear wall* shall be determined by principles of mechanics considering the deformation of the sheathing and its attachment, *chord studs, hold-downs and anchorage*.

E7 Conventional Construction Cold-Formed Steel Light Frame Strap Braced Wall Systems

E7.1 Scope

In Canada, conventional construction *cold-formed steel light frame strap braced wall* systems shall be designed in accordance with the requirements of this section. This *Standard* does not have provisions for this system that are applicable in the U.S. and Mexico.

E7.2 Basis of Design

Conventional construction *cold-formed steel light frame strap braced wall* systems are expected to withstand seismic demands primarily through generalized ductility in the system.

E7.2.1 Designated Energy-Dissipating Mechanism

There is no *designated energy-dissipating mechanism* for this system.

E7.2.2 Seismic Force Modification Factors and Limitations for Seismic Force-Resisting System

The *seismic force modification factors*, R_dR_o , shall be determined in accordance with the *applicable building code*. For conventional construction *cold-formed steel light frame strap braced wall* systems, the design shall comply with this section.

User Note:

In Canada, *seismic force modification factors*, R_dR_o , are generally determined from the NBCC. The system specified here is listed as $R_dR_o=1.56$ for conventional construction *strap braced walls*.

E7.2.3 Wall Aspect Ratio

The aspect ratio (h:w) of a conventional construction *strap braced wall* shall not exceed 2:1.

E7.2.4 Seismic Load Effects Contributed by Masonry and Concrete Walls

Seismic *load effects* contributed by masonry and concrete walls shall not be permitted to be resisted by conventional construction *cold-formed steel light frame strap braced wall* systems.

E7.3 Shear Resistance

E7.3.1 Nominal Resistance

For a conventional construction *strap braced wall*, the wall *nominal resistance* for shear, V_n , shall be determined by the governing limit state in the wall in accordance with AISI S100.

E7.3.2 Factored Resistance

The *factored resistance* ($\phi_v V_n$) shall be determined from the *nominal resistance* using the applicable *resistance factor* in AISI S100 for the governing limit state.

E7.4 System Requirements

E7.4.1 Limitations on System

The conventional construction *cold-formed steel* light frame *strap braced wall* system shall conform to Section E3.4.1(b) and Section E3.4.1(c).

E7.4.2 Effect of Eccentricity

The effect of eccentricity on effect of *factored loads* for *connections*, *chord studs*, and anchorages shall be considered in the design.

E7.4.3 Design Deflection

The deflection of a *strap braced wall* shall be determined by principles of mechanics considering the deformation of the *strap*, *chord studs*, *hold-downs* and anchorage.

F. DIAPHRAGMS

F1 General

F1.1 Scope

In the U.S. and Mexico, the design of *diaphragms* that resist seismic loads shall comply with the requirements of this section.

F1.2 Design Basis

Diaphragms work to collect and distribute inertial forces to the seismic force-resisting system. They are not intended to work as a prescribed *energy-dissipating mechanism*.

F1.3 Required Strength

For the purposes of determining *required strength*, the *diaphragm* shall be designated as rigid, semi-rigid, or flexible as specified in the *applicable building code*. Where stiffness is required for analysis, it shall be determined using mechanical properties of the *diaphragm*, as required by the *applicable building code*.

F1.3.1 Diaphragm Stiffness

Diaphragm stiffness shall be determined from the *applicable building code* or *rational engineering analysis*.

User Note:

A conservative approach is to calculate the *required strength* first assuming a rigid *diaphragm* and then assuming a flexible *diaphragm*, taking the worst-case scenario between the two.

F1.3.2 Seismic Load Effects Including Overstrength

Where required by the *applicable building code*, seismic load effects including overstrength shall be considered.

F1.4 Shear Strength

F1.4.1 Nominal Strength

The shear resistance of *diaphragms* shall be determined based on principles of mechanics considering fastener strength and the shear resistance of the *diaphragm* material. Where determined by the principles of mechanics, the *nominal strength* shall be the maximum resistance that the *diaphragm* is capable of developing.

F1.4.1.1 Diaphragms Sheathed With Wood Structural Panels

Alternatively for *diaphragms* sheathed with *wood structural panels*, the *nominal strength* is permitted to be determined by Section F2.

F1.4.2 Available Strength

The *available strength* ($\phi_v V_n$ or V_n/Ω_v) shall be determined from the *nominal strength* using the applicable *safety factors* and *resistance factors* given in AISI S100 for *diaphragms*

sheathed with profiled steel panels; Section F2.4.2 for *diaphragms* sheathed with *wood structural panels*; and the *applicable building code* for *diaphragms* with other *approved materials*.

F2 Cold-Formed Steel Diaphragms Sheathed With Wood Structural Panels

F2.1 Scope

Where the *seismic force-resisting system* is designed and constructed in accordance with Chapter E and the *diaphragm* is composed of *cold-formed steel* light frame construction sheathed with *wood structural panels*, the *diaphragm* shall be designed in accordance with this section.

F2.2 Additional Design Requirements

F2.2.1 Seismic Detailing Requirements

Where the applicable *seismic response modification coefficient*, R , is taken equal to or less than 3, in accordance with the *applicable building code*, the design shall comply with these requirements exclusive of those in Section F2.5.

Where the applicable *seismic response modification coefficient*, R , is taken greater than 3, in accordance with the *applicable building code*, the design shall comply with these requirements inclusive of those in Section F2.5.

F2.2.2 Seismic Load Effects Contributed by Masonry and Concrete Walls

Cold-formed steel floor and roof members sheathed with *wood structural panels* are permitted to be used in *diaphragms* to resist horizontal seismic forces contributed by masonry or concrete walls in structures two stories or less in height, provided such forces do not result in torsional force distribution through the *diaphragm*.

Wood structural panel sheathing in *diaphragms* supporting masonry or concrete walls shall have all unsupported edges blocked.

F2.3 Required Strength

The *required strength* of *diaphragms* and *diaphragm chords* shall be in accordance with the *applicable building code*. The *required strength* for *collectors* shall be determined from the expected strength of the *seismic force-resisting system*, but need not exceed the seismic load effect including overstrength.

F2.3.1 Diaphragm Stiffness

Stiffness for *cold-formed steel diaphragms* sheathed with *wood structural panels* shall be determined from the *applicable building code* or *rational engineering analysis*.

F2.4 Shear Strength

F2.4.1 Nominal Strength

The *nominal strength* of *diaphragms* sheathed with *wood structural panels* is permitted to be determined in accordance with Eq. F2.4.1-1 subject to the requirements in Section F2.4.1.1.

$$V_n = v_n L \quad (\text{Eq. F2.4.1-1})$$

where

L = *Diaphragm resistance length, in ft (m)*

v_n = *Nominal shear strength per unit length as specified in Table F2.4-1, lb/ft (kN/m)*

F2.4.1.1 Requirements for Tabulated Systems

The following requirements shall apply to *diaphragms* sheathed with *wood structural panels*:

- (a) The aspect ratio (length:width) of the *diaphragm* does not exceed 4:1 for blocked *diaphragms* and 3:1 for unblocked *diaphragms*.
- (b) *Joists* and *tracks* are ASTM A1003 Structural Grade 33 (Grade 230) Type H steel for members with a *designation thickness* of 33 and 43 mils, and ASTM A1003 Structural Grade 50 (Grade 340) Type H steel for members with a *designation thickness* equal to or greater than 54 mils.
- (c) The minimum *designation thickness* of *structural members* is 33 mils.
- (d) *Joists* are C-shape members with a minimum *flange* width of 1-5/8 in. (41.3 mm), minimum *web* depth of 3-1/2 in. (89 mm) and minimum *edge stiffener* of 3/8 in. (9.5 mm).
- (e) *Track* has a minimum *flange* width of 1-1/4 in. (31.8 mm) and a minimum *web* depth of 3-1/2 in. (89 mm).
- (f) Screws for *structural members* are a minimum No. 8 and are in accordance with ASTM C1513.
- (g) *Wood structural panel* sheathing is manufactured using exterior glue and complies with DOC PS-1 and DOC PS-2.
- (h) Screws used to attach *wood structural panels* are minimum No. 8 where *structural members* have a *designation thickness* of 54 mils or less and No. 10 where *structural members* have a *designation thickness* greater than 54 mils and comply with ASTM C1513.
- (i) Screws in the field of the panel are attached to intermediate supports at a maximum 12-in. (305 mm) spacing along the *structural members*.
- (j) Panels less than 12-in. (305-mm) wide are not used.
- (k) Maximum *joist* spacing is 24 in. (610 mm) on center.
- (l) Where *diaphragms* are designed as blocked, all panel edges are attached to *structural members* or *panel blocking*.
- (m) Where used as *blocking*, flat *strap* is a minimum thickness of 33 mils with a minimum width of 1-1/2 in. (38.1 mm) and is installed below the sheathing.
- (n) Where *diaphragms* are designed as blocked, the screws are installed through the sheathing to the *blocking*.
- (o) Fasteners along the edges in shear panels are placed from panel edges not less than 3/8 in. (9.5 mm).

F2.4.2 Available Strength

The *available strength* ($\phi_v V_n$ or V_n/Ω_v) shall be determined from the *nominal strength*

using the applicable *safety factors* and *resistance factors* given in this section in accordance with the applicable design method – *ASD* or *LRFD* as follows:

$$\Omega_v = 2.50 \quad (\text{ASD})$$

$$\phi_v = 0.60 \quad (\text{LRFD})$$

F2.4.3 Design Deflection

The deflection of a *diaphragm* with *wood structural panel* sheathing shown in Table F2.4-1 shall be determined by principles of mechanics considering the deformation of the sheathing and its attachment, *chords* and *collectors*.

Table F2.4-1
Nominal Shear Strength (v_n) per Unit Length for Diaphragms Sheathed
With Wood Structural Panel Sheathing ^{1, 2}
U.S. and Mexico (lb/ft)

Sheathing	Thick- ness (in.)	Blocked				Unblocked	
		Screw spacing at diaphragm boundary edges and at all continuous panel edges (in.)				Screws spaced maximum of 6 in. on all supported edges	
		6	4	2.5	2	Load perpendicular to unblocked edges and continuous panel joints	All other configurations
		Screw spacing at all other panel edges (in.)					
		6	6	4	3		
Structural I	3/8	768	1022	1660	2045	685	510
	7/16	768	1127	1800	2255	755	565
	15/32	925	1232	1970	2465	825	615
C-D, C-C and other graded wood structural panels	3/8	690	920	1470	1840	615	460
	7/16	760	1015	1620	2030	680	505
	15/32	832	1110	1770	2215	740	555

1. For SI: 1" = 25.4 mm, 1 ft = 0.305 m, 1 lb = 4.45 N

2. For *diaphragms* sheathed with *wood structural panels*, tabulated R_n values are applicable for short-term load duration (seismic loads).

F2.5 Requirements Where the Seismic Response Modification Coefficient, R , is Greater Than Three

Where the *seismic response modification coefficient*, R , used to determine the lateral forces is taken greater than 3 and the *diaphragm* is constructed with *cold-formed steel* framing sheathed with *wood structural panels*, the *diaphragm* shall meet the additional requirements in this section.

F2.5.1 Open Front Structures

Open front structures with rigid *diaphragms* sheathed with *wood structural panels* resulting in torsional force distribution shall be limited by the following:

- (a) The length of the *diaphragm* normal to the open side cannot exceed 25 ft (7.62 m), and the aspect ratio (length:width) is less than 1:1 for one-story structures or 2:3 for structures over one story in height, where the length dimension of the *diaphragm* is perpendicular to the opening.
- (b) Where calculations show that *diaphragm* deflections can be tolerated, the length normal to the opening is permitted to be increased to an aspect ratio (length:width) not greater than 3:2.

F2.5.2 Member Requirements

Wood structural panel sheathing shall be arranged so that the minimum panel width is not less than 24 in. (610 mm).

F3 Other Diaphragms

[Reserved]

G. QUALITY CONTROL AND QUALITY ASSURANCE

G1 Cold-Formed Steel Light Frame Shear Walls Sheathed With Wood Structural Panels

Quality control and quality assurance for *cold-formed steel* light frame *shear walls* sheathed with *wood structural panels* rated for shear resistance shall be in accordance with Chapter D of AISI S240.

G2 Cold-Formed Steel Light Frame Shear Walls Sheathed with Steel Sheets

Quality control and quality assurance for *cold-formed steel* light frame *shear walls* with *steel sheet sheathing* shall be in accordance with Chapter D of AISI S240.

G3 Cold-Formed Steel Light Frame Strap Braced Wall Systems

Quality control and quality assurance for *cold-formed steel* light frame *strap braced walls* shall be in accordance with Chapter D of AISI S240.

G4 Cold-Formed Steel Special Bolted Moment Frames (CFS-SBMF)

The fabricator shall provide *quality control* procedures to the extent that the fabricator deems necessary to ensure that the work is performed in accordance with this *Standard*. In addition to the fabricator's *quality control* procedures, material and workmanship at all times are permitted to be subject to inspection by qualified inspectors representing the *owner*. If such inspection by the *owner's representatives* will be required, it shall be so stated in the *construction documents*.

G4.1 Cooperation

Where possible, the inspection by *owner's representatives* shall be made at the fabricator's plant. The fabricator shall cooperate with the inspector, permitting access for inspection to all places where work is being done. The *owner's* inspector shall schedule this work for minimum interruption to the work of the fabricator.

G4.2 Rejections

Material or workmanship not in conformance with the provisions of this *Standard* are permitted to be rejected at any time during the progress of the work.

The fabricator shall receive copies of all reports furnished to the *owner* by the inspection agency.

G4.3 Inspection of Welding

The inspection of welding shall be in accordance with the provisions of AWS D1.1 and AWS D1.3, as applicable. When visual inspection is required to be performed by AWS-certified welding inspectors, it shall be specified in the *construction documents*. When nondestructive testing is required, the process, extent, and standards of acceptance shall be defined in the *construction documents*.

G4.4 Inspection of Bolted Connections

Connections shall be inspected to verify that the fastener *components* are as specified and that the *joint* plies have been drawn into firm contact. A representative sample of bolts shall be evaluated using an ordinary spud wrench to ensure that the bolts in the *connections* have been tightened to a level equivalent to that of the full effort of a worker equipped with such wrench.

G4.5 Identification of Steel

The fabricator shall be able to demonstrate by a written procedure and by actual practice a method of material identification, visible at least through the “fit-up” operation, for the main structural elements of each shipping piece.

G5 Cold-Formed Steel Light Frame Shear Walls Sheathed With Wood-Based Structural Panels and Gypsum Board Panels in Combination

Quality control and quality assurance for *cold-formed steel* light frame *shear walls* sheathed with wood-based structural panels and gypsum board panels in combination shall be in accordance with Chapter D of AISI S240.

G6 Cold-Formed Steel Light Frame Shear Walls Sheathed With Gypsum Board or Fiberboard Panels

Quality control and quality assurance for *cold-formed steel* light frame *shear walls* sheathed with gypsum board panels or *fiberboard* panels shall be in accordance with Chapter D of AISI S240.

H. Use of Substitute Components and Connections in Seismic Force-Resisting Systems

The substitution of *components* or *connections* into one of the *seismic force-resisting systems* specified in Chapter E shall be in accordance with the *applicable building code* and subject to the approval of the *authority having jurisdiction*.

APPENDIX 1, SEISMIC FORCE MODIFICATION FACTORS AND LIMITATIONS IN CANADA

1.1 Scope and Applicability

This appendix applies to Canada. It contains design coefficients, system limitations and design parameters for *seismic force-resisting systems* that are included in this *Standard*, but are not yet defined in the *applicable building code*. The values presented in this appendix shall only be used where neither the *applicable building code* nor the NBCC contain such values.

1.2 Seismic Force Modification Factors and Limitations in Canada

In Canada, the ductility-related *seismic force modification factor*, R_d , the overstrength-related *seismic force modification factor*, R_o , and restrictions for *cold-formed steel seismic force-resisting systems* that are to be designed for *seismic loads* in conjunction with the *applicable building code* shall be as listed in Table 1.2-1. In addition, gypsum board *shear walls* shall not be used alone to resist lateral loads and the use of gypsum board in *shear walls* shall be limited to structures four stories or less in height, in accordance with Table 1.2-2.

Table 1.2-1
Canada
Design Coefficients and Factors for Seismic Force-Resisting Systems in Canada

Type of Seismic Force-Resisting System	R_d	R_o	Building Height (m) Limitations ¹				
			Cases Where $I_E F_a S_a(0.2)$				Cases Where $I_E F_v S_a(1.0)$
			< 0.2	≥ 0.2 to < 0.35	≥ 0.35 to ≤ 0.75	> 0.75	> 0.3
Shear Walls ²							
Screw-connected shear walls: wood-based structural panel	2.5	1.7	20	20	20	20	20
Screw-connected shear walls: wood based structural and gypsum panels in combination	1.5	1.7	20	20	20	20	20
Steel sheet sheathed shear walls	2.0	1.3	15	15	15	15	15
Strap Braced Walls ³							
Limited ductility braced wall ⁴	1.9	1.3	20	20	20	20	20
Conventional construction ⁵	1.2	1.3	15	15	NP	NP	NP
Other Cold-Formed Steel Seismic Force-Resisting System(s)	1.0	1.0	15	15	NP	NP	NP

1. NP = Not Permitted.

2. *Seismic Force-Resisting System* specifically detailed for ductile seismic performance. *Capacity-based design* approach is applied, assuming the sheathing *connections* act as the energy-dissipating element (See Section E1, Section E2 and Section E5, as applicable).

3. *Seismic Force-Resisting System* specifically detailed so that all members of the *bracing* system are subjected primarily to axial forces. The eccentric effect due to single-sided *bracing* is neglected for purposes of this classification, but is considered in accordance with Section E3 and Section E7.

4. *Seismic Force-Resisting System* specifically detailed for ductile seismic performance. *Capacity-based design* approach is applied, assuming the braces act as the energy-dissipating element (*gross cross-section yielding*). See Section E3.

5. Lateral system not specifically detailed for ductile seismic performance (*Capacity-based design* approach not required. See Section E7).

Table 1.2-2
Canada
Maximum Percentage of Total Shear Forces Resisted by Gypsum Board in a Story

Story	Percentage of Shear Forces			
	Stories in Building			
	4	3	2	1
4th	80	-	-	-
3rd	60	80	-	-
2nd	40	60	80	-
1st	40	40	60	80



AISI STANDARD

**Commentary on
North American Standard
for Seismic Design of
Cold-Formed Steel
Structural Systems**

2015 Edition With Supplement 1

DISCLAIMER

The material contained herein has been developed by the American Iron and Steel Institute (AISI) Committee on Framing Standards. The Committee has made a diligent effort to present accurate, reliable, and useful information on seismic design for cold-formed steel structures. The Committee acknowledges and is grateful for the contributions of the numerous researchers, engineers, and others who have contributed to the body of knowledge on the subject. Specific references are included in the *Commentary* on the Standard.

With anticipated improvements in understanding of the behavior of cold-formed steel and the continuing development of new technology, this material will become dated. It is anticipated that AISI will publish updates of this material as new information becomes available, but this cannot be guaranteed.

The materials set forth herein are for general purposes only. They are not a substitute for competent professional advice. Application of this information to a specific project should be reviewed by a registered professional engineer. Indeed, in many jurisdictions, such a review is required by law. Anyone making use of the information set forth herein does so at their own risk and assumes any and all liability arising therefrom.

First Printing – December 2015
Second Printing – September 2016

Copyright American Iron and Steel Institute 2015

PREFACE

The American Iron and Steel Institute (AISI) Committee on Framing Standards has developed this first edition of the *North American Standard for Seismic Design of Cold-Formed Steel Structural Systems* (hereinafter referred to as this *Standard*) in 2015. This *Standard* is intended to address the design and construction of *lateral force-resisting systems* used in buildings and *other structures* framed from *cold-formed steel structural members and connections* appropriate for seismic design. This *Standard* provides the lateral capacity and necessary detailing for specific *seismic force-resisting systems* such that appropriate seismic response factors may be applied in the analysis and design. In this first edition, the material represents a merging of AISI S110, *Standard for Seismic Design of Cold-Formed Steel Structural Systems – Special Bolted Moment Frames*, 2007 Edition with Supplement No. 1-09, and the seismic portions of AISI S213, *North American Standard for Cold-Formed Steel Framing – Lateral Design*, 2007 Edition with Supplement No. 1-09. In addition, some of the seismic design requirements stipulated in this *Standard* are drawn from ANSI/AISC 341-10, *Seismic Provisions for Structural Steel Buildings*, developed by the American Institute of Steel Construction. The application of this *Standard* should be in conjunction with AISI S100, *North American Specification for the Design of Cold-Formed Steel Structural Members* (hereinafter referred to as AISI S100), and AISI S240, *North American Standard for Cold-Formed Steel Framing* (hereinafter referred to AISI S240).

The Lateral Design Subcommittee of the AISI Committee on Framing Standards is responsible for the ongoing development of this *Standard*. The AISI Committee on Framing Standards gives the final approval of this document through an ANSI-accredited balloting process.

The Committee acknowledges and is grateful to the numerous engineers, researchers, producers and others who have contributed to the body of knowledge on these subjects. AISI further acknowledges the permission of the American Institute of Steel Construction for adopting provisions from its *Seismic Provisions for Structural Steel Buildings*.

In the second printing of this standard, Supplement 1 to AISI S400-15-C is incorporated.

American Iron and Steel Institute
November 2015
Updated September 2016

This Page is Intentionally Left Blank.

TABLE OF CONTENTS
COMMENTARY ON NORTH AMERICAN STANDARD FOR
SEISMIC DESIGN OF COLD-FORMED STEEL STRUCTURAL SYSTEMS
WITH SUPPLEMENT 1

Disclaimer	ii
Preface.....	iii
COMMENTARY ON NORTH AMERICAN STANDARD FOR SEISMIC DESIGN OF COLD-FORMED	
STEEL STRUCTURAL SYSTEMS WITH SUPPLEMENT 1	1
A. GENERAL	1
A1 Scope and Applicability.....	1
A1.1 Scope.....	1
A1.2 Applicability.....	1
A2 Definitions	2
A2.1 Terms.....	2
A3 Materials	2
A3.2 Expected Material Properties.....	3
A3.2.1 Material Expected Yield Stress [Probable Yield Stress].....	3
A3.2.2 Material Expected Tensile Strength [Probable Tensile Strength].....	4
A3.2.3 Material Modified Expected Yield Stress [Modified Probable Yield Stress].....	4
A3.3 Consumables for Welding.....	4
A4 Structural Design Drawings and Specifications.....	4
A5 Reference Documents	4
B. GENERAL DESIGN REQUIREMENTS	5
B1 General Seismic Design Requirements.....	5
B1.1 General.....	5
B1.2 Load Path.....	5
B1.3 Deformation Compatibility of Members and Connections Not in the Seismic Force-Resisting System	5
B1.4 Seismic Load Effects Contributed by Masonry and Concrete Walls.....	6
B1.5 Seismic Load Effects From Other Concrete or Masonry Components	6
B2 Lateral Force-Resisting System.....	7
B3 Design Basis.....	7
B3.3 Expected Strength [Probable Resistance].....	7
C. ANALYSIS.....	9
C1 Seismic Load Effects.....	9
D. GENERAL MEMBER AND CONNECTION DESIGN REQUIREMENTS.....	9
E. SEISMIC FORCE-RESISTING SYSTEMS	10
E1 Cold-Formed Steel Light Frame Shear Walls Sheathed With Wood Structural Panels	10
E1.1 Scope.....	10
E1.2 Basis of Design	10
E1.2.1 Designated Energy-Dissipating Mechanism.....	10
E1.2.2 Seismic Design Parameters [Seismic Force Modification Factors and Limitations] for Seismic Force-Resisting System	11
E1.2.3 Type I or Type II Shear Walls.....	12
E1.2.4 Seismic Load Effects Contributed by Masonry and Concrete Walls.....	14
E1.3 Shear Strength [Resistance].....	14
E1.3.1.1 Type I Shear Walls.....	14

E1.3.1.1.1	Wall Pier Limitations.....	18
E1.3.1.1.2	Both Wall Faces Sheathed With the Same Material and Fastener Spacing	19
E1.3.1.1.3	More Than a Single Sheathing Material or Fastener Configuration	19
E1.3.1.2	Type II Shear Walls	20
E1.3.2	Available Strength [Factored Resistance].....	20
E1.3.3	Expected Strength [Probable Resistance]	21
E1.4	System Requirements.....	22
E1.4.1	Type I Shear Walls	22
E1.4.1.1	Limitations for Tabulated Systems	22
E1.4.1.2	Required Strength [Effect Due to Factored Loads] for Chord Studs, Anchorage, and Collectors	23
E1.4.1.3	Required Strength [Effect Due to Factored Loads] for Foundations.....	23
E1.4.1.4	Design Deflection	23
E1.4.2	Type II Shear Walls.....	25
E1.4.2.1	Additional Limitations	25
E1.4.2.2	Required Strength [Effect Due to Factored Loads] for Chord Studs, Anchorage, and Collectors	25
E1.4.2.2.1	Collectors Connecting In-Plane Type II Shear Wall Segments.	25
E1.4.2.2.2	Uplift Anchorage and Boundary Chord Forces at Type II Shear Wall Ends	25
E1.4.2.2.3	Uplift Anchorage Between Type II Shear Wall Ends.....	25
E1.4.2.3	Design Deflection	26
E2	Cold-Formed Steel Light Frame Shear Walls With Steel Sheet Sheathing.....	27
E2.2	Basis of Design.....	27
E2.2.1	Designated Energy -Dissipating Mechanism.....	27
E2.2.2	Seismic Design Parameters [Seismic Force Modification Factors and Limitations] for Seismic Force-Resisting System	27
E2.2.3	Type I or Type II Shear Walls.....	28
E2.2.4	Seismic Load Effects Contributed by Masonry and Concrete Walls.....	28
E2.3	Shear Strength [Resistance].....	28
E2.3.1	Nominal Strength [Resistance].....	28
E2.3.1.1	Type I Shear Walls.....	29
E2.3.1.1.1	Effective Strip Method.....	29
E2.3.1.1.2	Wall Pier Limitations.....	29
E2.3.1.1.3	Both Wall Faces Sheathed With the Same Material and Fastener Spacing	30
E2.3.1.1.4	More Than a Single Sheathing Material or Fastener Configuration	30
E2.3.1.2	Type II Shear Walls	30
E2.3.2	Available Strength [Factored Resistance].....	30
E2.3.3	Expected Strength [Probable Resistance]	30
E2.4	System Requirements.....	30
E2.4.1	Type I Shear Walls	30
E2.4.1.1	Limitations for Tabulated Systems	30

E2.4.1.2	Required Strength [Effect Due to Factored Loads] for Chord Studs, Anchorage, and Collectors	30
E2.4.1.3	Required Strength [Effect Due to Factored Loads] for Foundations.....	30
E2.4.1.4	Design Deflection	30
E2.4.2	Type II Shear Walls.....	31
E3	Cold-Formed Steel Light Frame Strap Braced Wall Systems	31
E3.2	Basis of Design.....	31
E3.2.1	Designated Energy-Dissipating Mechanism.....	31
E3.2.2	Seismic Design Parameters [Seismic Force Modification Factors and Limitations] for Seismic Force-Resisting System	31
E3.2.3	Seismic Load Effects Contributed by Masonry and Concrete Walls.....	32
E3.3	Shear Strength [Resistance].....	32
E3.3.1	Nominal Strength [Resistance].....	32
E3.3.2	Available Strength [Factored Resistance].....	32
E3.3.3	Expected Strength [Probable Resistance]	32
E3.4	System Requirements.....	33
E3.4.1	Limitations on System.....	33
E3.4.2	Required Strength [Effect of Factored Loads] for Seismic Force-Resisting System.....	36
E3.4.3	Required Strength [Effect of Factored Loads] for Foundations	36
E3.4.4	Design Deflection.....	36
E4	Cold-Formed Steel Special Bolted Moment Frames (CFS-SBMF).....	37
E4.1	Scope.....	37
E4.2	Basis of Design.....	37
E4.2.1	Designated Energy- Dissipating Mechanism.....	37
E4.2.2	Seismic Design Parameters for Seismic Force-Resisting System.....	39
E4.2.3	Seismic Load Effects Contributed by Masonry and Concrete Walls.....	40
E4.3	Strength.....	40
E4.3.1	Required Strength.....	40
E4.3.1.1	Beams and Columns	40
E4.3.1.2	Bolt Bearing Plates.....	40
E4.3.2	Available Strength	41
E4.3.3	Expected Strength.....	41
E4.4	System Requirements.....	48
E4.4.1	Limitations on System.....	48
E4.4.2	Beams.....	50
E4.4.3	Columns	51
E4.4.4	Connections, Joints and Fasteners	51
E4.4.4.1	Bolted Joints	52
E4.4.4.1.1	Beam- to-Column Connections.....	52
E4.4.4.1.2	Bolt Bearing Plates	53
E4.4.4.2	Welded Joints.....	53
E4.4.4.3	Other Joints and Connections.....	54
E5	Cold-Formed Steel Light Frame Shear Walls With Wood Structural Panel Sheathing on One Side and Gypsum Board Panel Sheathing on the Other Side	55
E5.1	Scope.....	55
E5.2	Basis of Design.....	55

E5.3 Shear Resistance.....	55
E5.4 System Requirements.....	55
E6 Cold-Formed Steel Light Frame Shear Walls With Gypsum Board or Fiberboard Panel Sheathing	56
E6.1 Scope.....	56
E6.2 Basis of Design.....	56
E6.3 Shear Strength.....	57
E6.4 System Requirements.....	58
E7 Conventional Construction Cold-Formed Steel Light Frame Strap Braced Wall Systems	59
E7.1 Scope.....	59
E7.2 Basis of Design.....	59
E7.3 Shear Resistance.....	59
E7.4 System Requirements.....	59
F. DIAPHRAGMS.....	60
F1 General.....	60
F1.1 Scope.....	60
F1.2 Design Basis.....	60
F1.3 Required Strength.....	60
F1.4 Shear Strength.....	61
F2 Cold-Formed Steel Diaphragms Sheathed With Wood Structural Panels	61
F2.1 Scope.....	61
F2.2 Additional Design Requirements.....	61
F2.3 Required Strength.....	61
F2.4 Shear Strength.....	61
F2.4.1 Nominal Strength.....	61
F2.4.2 Available Strength	62
F2.4.3 Design Deflection.....	62
F2.5 Requirements Where Seismic Response Modification Coefficient, R, Greater Than Three.....	63
F3 Other Diaphragms.....	63
G. QUALITY CONTROL AND QUALITY ASSURANCE.....	64
H. USE OF SUBSTITUTE COMPONENTS AND CONNECTIONS IN SEISMIC FORCE-RESISTING SYSTEMS	65
APPENDIX 1, SEISMIC FORCE MODIFICATION FACTORS AND LIMITATIONS IN CANADA	67
REFERENCES.....	68

COMMENTARY ON NORTH AMERICAN STANDARD FOR SEISMIC DESIGN OF COLD-FORMED STEEL STRUCTURAL SYSTEMS WITH SUPPLEMENT 1

A. GENERAL

This *Standard* provides the shear (lateral) capacity of *seismic force-resisting systems* appropriate for use in buildings and other structures framed from *cold-formed steel structural members* in seismic design. To develop the designated shear capacity and the overall response appropriate for the *seismic performance factors* associated with a given *seismic force-resisting system*, this *Standard* also provides the necessary detailing and design of the complete *lateral force-resisting system*, including the diaphragm.

In this first edition, the material represents a merging of AISI S110, *Standard for Seismic Design of Cold-Formed Steel Structural Systems – Special Bolted Moment Frames, 2007 Edition with Supplement No. 1-09*, and the seismic portions of AISI S213, *North American Standard for Cold-Formed Steel Framing – Lateral Design, 2007 with Supplement No. 1-09*. In addition, some of the seismic design requirements stipulated in this *Standard* are drawn from ANSI/AISC 341-10, *Seismic Provisions for Structural Steel Buildings*, developed by the American Institute of Steel Construction (AISC, 2010). The application of this *Standard* should be in conjunction with AISI S100, *North American Specification for the Design of Cold-Formed Steel Structural Members* (hereinafter referred to as AISI S100), and AISI S240, *North American Standard for Cold-Formed Steel Framing* (hereinafter referred to AISI S240).

A1 Scope and Applicability

A1.1 Scope

Buildings and other structures framed from *cold-formed steel structural members* may be designed using this *Standard* to design *seismic force-resisting systems* including the necessary detailing, *connections* and *components*, *diaphragm* design, and load transfer through the complete *lateral force-resisting system* appropriate for seismic design and *seismic response factors* selected from an appropriate load standard (as referenced from an *applicable building code*). Each *seismic force-resisting system* detailed in this *Standard* has a *designated energy dissipating mechanism* that is protected through detailing and provides a means to dissipate seismic energy at a level appropriate to that system. This *Standard* supplements the *applicable building code*, AISI S100 [CSA S136], and AISI S240.

A1.2 Applicability

This *Standard* is applicable for seismic design of buildings and other structures framed from *cold-formed steel structural members*. Conventional *cold-formed steel* construction has inherent overstrength and ductility that may be utilized in certain situations for seismic design. The *Standard* provides the specific case, detailed in this section (e.g. Seismic Design Category B or C and $R = 3$ in the United States), where the provisions of this *Standard* are not mandatory for seismic design.

This *Standard* is not applicable to *cold-formed steel* rack structures, which should be designed in accordance with the latest edition of *Design Testing and Utilization of Industrial Steel Storage Racks* by the Rack Manufacturers Institute (RMI). The RMI standard recognizes and provides design methodologies for the unique *energy-dissipating mechanisms* used in those

structures.

This *Standard* does not address the seismic design of *cold-formed steel nonstructural members*.

A1.2.3 The intent is for this *Standard* to govern whenever seismic detailing is required for a *seismic force-resisting system*. The only ASCE/SEI 7 *cold-formed steel* structural system permitted to exclude seismic detailing is the R=3 system in Line H of ASCE/SEI 7 Table 12.2-1—“Steel Systems Not Specifically Detailed for Seismic Resistance, Excluding Cantilever Column Systems” (ASCE, 2010). This system is permitted only in *Seismic Design Category* (SDC) B or C. This is similar to the approach that is currently taken for ANSI/AISC 341 (AISC, 2010). There are a number of systems that have a *response modification coefficient* less than three that have important seismic detailing requirements. For instance, if a gypsum board shear wall (R=2.5) is the designated *seismic force-resisting system* for a building, then it needs to meet the requirements found in AISI S400.

A2 Definitions

Codes and standards by their nature are technical, and specific words and phrases can change the intent of the provisions if not properly defined. As a result, it is necessary to establish a common platform by clearly stating the meaning of specific terms for the purpose of this *Standard* and other standards that reference this *Standard*.

A2.1 Terms

In 2015, the term “boundary member” was revised to “*boundary element*” to be consistent with the definition in ASCE/SEI 7.

For multi-level buildings, *boundary elements* and *chords* should also include those at intermediate floor levels as the seismic forces in those floors need to be transferred to the vertical *seismic force-resisting system*.

Other terms defined in this section are self-explanatory.

A3 Materials

The ASTM steel designations and grades that are permitted by this *Standard* are based on those listed in AISI S100, AISI S240, and ANSI/AISC 341. In addition, ASTM A1085 was added. ASTM A1085 includes Grade 50 [$F_y = 50$ ksi (345 MPa) and $F_t = 65$ ksi (448 MPa)]. In the *Standard*, some grades within designations are excluded to ensure a higher level of ductility and reserve strength for inelastic seismic loadings.

Grades excluded include A500 hollow structural sections Grades A and D; A572/A572M Grades 60 (415) and 65 (450); and Grades 70 (480) and 80 (550) of the various sheet specifications (A653/A653M, A875/A875M, A1008/A1008M, and A1011/A1011M). The remaining grades provide a F_u/F_y ratio not less than 1.15 and an elongation in 2 in. (50 mm) not less than 12 percent except for a few cases. The elongation is 11 and 9 percent for A1011/A1011M Grades 50 (340) and 55 (380), respectively, in thicknesses from 0.064 in. (2.5 mm) to 0.025 in. (0.65 mm). The elongation is 10 percent and the ratio 1.08 for all ST grades of A1003/A1003M.

In general, *cold-formed steel structural members* are formed from ASTM A1003/1003M (ASTM, 2011a) designated steel. As detailed in AISI S240, ASTM A1003/1003M provides minimum mechanical requirements. For seismic design, only ASTM A1003/1003M grades ST33H, ST37H, ST40H, and ST50H are applicable as they provide an elongation minimum (10 percent) and F_u/F_y ratio minimum (1.08) that are appropriate for this *Standard*.

A3.2 Expected Material Properties

Steel design is generally conducted with nominal properties; however, in seismic design it is often important to provide the best possible estimate of the expected (probable) properties. For example, if it is intended that one particular member yield, it is important to realize that this member will most probably yield at force levels significantly higher than those based on the nominal yield stress. This higher level is the expected [probable] property and is provided in this section through a series of modifiers (R_y , R_t , etc.) to the nominal mechanical properties.

A3.2.1 Material Expected Yield Stress [Probable Yield Stress]

The provided R_y and R_t values are based primarily on a database of typical properties of as-produced plate (Brockenbrough, 2003). The database included a significant quantity of relatively thin material (some supplied in coil form). The ratio of the mean yield stress to the *specified minimum yield stress* and the ratio of the mean tensile strength to the *specified minimum tensile strength* were as follows:

Table C-A3.2-1
Ratios of Mean-to-Specified Yield Stress and Mean-to-Specified Tensile Strength

ASTM Designation	Thickness Range, in. (mm)	No. of Data Items	Ratio of Mean-to-Specified Yield Stress	Ratio of Mean-to-Specified Tensile Strength
A36/A36M	0.188-0.75 (4.78-19.0)	14,900	1.30	1.17
A572/A772M Grade 50 (340)	0.188-0.50 (4.78-12.7)	1,161	1.17	1.18
A588/A588M	0.312-2.00 (7.70-50.8)	1,501	1.18	1.15

These values were generally supported by a subsequent study that included limited additional data and a review of existing data (Liu, et al., 2007). Rounded values were adopted for this *Standard*, which agree with those for plate material in ANSI/AISC 341. Although no data for the other plate steels listed in Table A3.2-1 of this *Standard* were available, it was considered likely that the ratios for ASTM A242/A242M, A283/A283M, and A529/A529M steel would be in the same range.

The R_y and R_t ratios for hollow structural sections for ASTM A500 Grades B and C steels were based on the data collected in 2015 by Judy Liu of Purdue University for the American Institute of Steel Construction (Liu, 2013), and these for ASTM A1085 steels were based on the data collected in 2015 by Kim Olson of FORSE Consulting for the Steel Tube Institute. The R_y and R_t ratios for all sheet and strip grades (ASTM A606, A653/A653M, A792/A792M, A875, A1003/A1003M, A1008/A1008M, and A1011/A1011M) were based on a 1995 study made by Bethlehem Steel for the U.S. Army Corps of Engineers on ASTM A653 (ASTM, 2002) material. In this study, data were gathered from two galvanized coating lines, where the conditions of the lines varied significantly so as to provide a good range of test results. However, the user is cautioned that while over 1000 coils were included in the study, individual sample size (grade/coating) varied from as few as 30 to as many as 717 coils. An individual sample may include several thicknesses for a given sample grade and coating.

This *Standard* allows R_y and R_t to be determined in accordance with an *approved* test

method. Such a test method should prescribe a minimum of one tensile test per coil and not permit use of mill test reports. If a test value for R_y is available, the use of the test value is optional if less than the value in Table A3.2-1; however, the test value must be used if greater than the value in Table A3.2-1. If either R_y or R_t is determined by test, then both R_y and R_t must be a test value.

A3.2.2 Material Expected Tensile Strength [Probable Tensile Strength]

Determination of the expected [probable] tensile strength is detailed in the previous section.

A3.2.3 Material Modified Expected Yield Stress [Modified Probable Yield Stress]

For flexural members, the expected strength [probable resistance] may exceed the *nominal strength* [*nominal resistance*] due to factors beyond virgin steel mechanical properties (i.e., beyond R_y , and R_t). The two most prominent are increased capacity due to cold work of forming in the corners of the cross-section, and increased capacity due to inelastic reserve in bending, i.e., R_{cf} and R_{re} , respectively.

R_{cf} , the factor to account for the increase in yield stress due to cold work of forming, may be determined by the provisions of AISI S100; alternatively, a minimum value of 1.10 may be used. This minimum is based on a review of typical *cold-formed steel* channel sections. An R_{cf} of 1.10 may be somewhat conservative for sections that are not fully effective, because the more limited effects of cold working are included indirectly in the basic strength equations for those sections.

R_{re} , the factor to account for increased capacity due to inelastic bending, may be determined by the provisions of AISI S100. Although *cold-formed steel* sections are not commonly designed for capacity greater than first yield in bending (i.e., M_y), experiments and models show that for many sections, particularly those 0.097 in (2.4mm) and thicker, it is not at all uncommon. This consideration may be particularly important for the *cold-formed steel* Special Bolted Moment Frames and similar systems.

A3.3 Consumables for Welding

In addition to AWS, relevant commentary on consumables for welding may be found in ANSI/AISC 341 (AISC, 2010) Section A3.4, where applicable.

A4 Structural Design Drawings and Specifications

Seismic design requires more than typical coordination across multiple standards. To provide clarity, this *Standard* requires that specifications and design drawings clearly designate the *seismic force-resisting systems* selected from Chapter E along with the additional *components* and *connections* within a given *seismic force-resisting system*, as well as the *components* and *connections* between *seismic force-resisting systems* that allow the complete *lateral force-resisting system* to work. In addition to the provided requirements, relevant commentary on structural design drawing and specifications may be found in the AISI S202 (2015), and ANSI/AISC 341 (AISC, 2010) Section A4.1.

A5 Reference Documents

Seismic design requires significant coordination across standards and other documents. The documents listed here are the intended references based on the current version of this *Standard*.

B. GENERAL DESIGN REQUIREMENTS

Seismic design of buildings or other structures framed from *cold-formed steel structural members* consists of general seismic design requirements and the design of the *lateral force-resisting system*, which itself relies on a specific design basis detailed herein. The general seismic design requires consideration of the potential earthquake hazard, which is a function of location, occupancy, and building characteristics—most importantly mass, period, and damping. The general seismic design results in a required base shear capacity and a series of assumptions about the *lateral force-resisting system* that are embodied in the selected *seismic response factors* (e.g., R , C_d , and Ω_o in the United States, or R_d and R_o in Canada) and in the selected *seismic force-resisting system*.

This *Standard* provides the shear (lateral) capacity of a variety of *cold-formed steel* appropriate *seismic force-resisting systems*, and provides the necessary detailing for the selected systems to develop the inelastic and overstrength response assumed from the general seismic design from an *applicable building code*. Within each *seismic force-resisting system*, a specific *energy-dissipating mechanism* is designated. This mechanism must be protected for the *seismic force-resisting system* to behave as intended. Therefore, the expected strength of this mechanism must be determined, and all *connections* and *components* that are in the load path of this mechanism must be able to develop this load or the maximum load expected in the *connection* or *component* from the earthquake including overstrength. In addition, the complete *lateral force-resisting system* includes the selected *seismic force-resisting systems*, *connections* and *components* between these systems, and the *diaphragm*, all of which must be designed to ensure the *energy-dissipating mechanisms* in the *seismic force-resisting systems* are able to occur.

B1 General Seismic Design Requirements

B1.1 General

Any seismic design may follow this *Standard*, but it is presumed that the *required strength* [effects due to *factored loads*] of the *lateral force-resisting system* as a whole and the *seismic force-resisting systems* in specific are known from the general seismic design. Further, it is presumed that inelasticity and overstrength associated with the selected *seismic force-resisting systems* were considered when developing the *required strengths* [effects due to *factored loads*], as is the case in ASCE/SEI 7 and NBCC.

B1.2 Load Path

The engineer is responsible for detailing a complete and explicit load path for the *lateral force-resisting system*. This path should be envisioned from the collected forces at the base of the structure to all points of mass in the structure. Since most mass is carried by the floors, the *load path* should consider horizontal systems such as *diaphragms*, *chords* and *collectors* (drag struts) and details of the vertical system such as the *seismic force-resisting system* and *connections* and *components* between *seismic force-resisting systems*, as well as multi-floor and foundation *connections* and related *components* (e.g. *hold-downs* and anchorage).

B1.3 Deformation Compatibility of Members and Connections Not in the Seismic Force-Resisting System

Seismic force-resisting systems may result in larger lateral drifts than those in other common lateral designs such as wind. Once the *design story drift* is determined, depending on the

applicable building code, designated *components* and *connections* must be checked to determine if they can accommodate the drift. This is an important consideration, as secondary *components* or other unintended (potentially brittle) *load* paths may be engaged if deformations are not accommodated. For additional relevant commentary on deformation compatibility of members and *connections* not in the *seismic force-resisting system*, see ANSI/AISC 341(AISC, 2010) Commentary Section D3.

B1.4 Seismic Load Effects Contributed by Masonry and Concrete Walls

The use of *cold-formed steel seismic force-resisting systems* with masonry or concrete walls is common practice. However, due to significant differences in stiffness and response, care must be taken. Specific details are provided for each vertical *seismic force-resisting system* in Chapter E and for the *diaphragm* in Chapter F.

The Chapter E requirements are patterned after provisions in the *Special Design Provisions for Wind and Seismic* (AFPA, 2005b) and were adopted in a precursor to this *Standard* in 2007 (AISI S213-07). As detailed in Chapter E, when the *cold-formed steel seismic force-resisting systems* resist seismic forces contributed by masonry and concrete walls, deflections are limited to 0.7% of the story height at *LRFD design load* [*factored load*] levels in accordance with deflection limits for masonry and concrete construction and Section 12.8.6 of ASCE/SEI 7 (ASCE, 2010). The intent is to limit failure of the masonry or concrete portions of the structure due to excessive deflection.

As detailed in Chapter F, *wood structural panel sheathed diaphragms* are not permitted where forces contributed by masonry or concrete walls result in torsional force distribution through the *diaphragm*. A torsional force distribution through the *diaphragm* would occur when the center of rigidity is not coincident with the center of mass, such as in an open front structure, a condition which is prohibited in Chapter F.

It should also be noted that Section 12.10.2.1 of ASCE/SEI 7 (ASCE, 2010) requires that *collectors*, splices, and their *connections* to resisting *components* be designed for the amplified seismic *load* when a structure is not braced entirely by light-frame *shear walls*. This imposes an additional requirement for *collectors* when *cold-formed steel* framing is used to resist seismic forces contributed by masonry and concrete walls.

B1.5 Seismic Load Effects From Other Concrete or Masonry Components

Seismic forces from other concrete or masonry construction (i.e., other than walls) are permitted and should be accounted for in design. The provisions of this section specifically allow masonry veneers; i.e., a masonry facing attached to a wall for the purpose of providing ornamentation, protection or insulation, but not counted as adding strength to the wall. Likewise, the provisions of this section are not intended to restrict the use of concrete floors—including *cold-formed steel framed* floors with concrete toppings as well as reinforced concrete slabs—or similar *components* in floor construction. It is intended that where such *components* are present in combination with a *cold-formed steel* framed system, the *cold-formed steel* framed system needs to be designed to account for the seismic forces generated by the additional mass of such *components*. The design of *cold-formed steel* members to support the additional mass of concrete and masonry *components* needs to be in accordance with AISI S100 [CSA S136] and required deflection limits as specified in concrete or masonry standards or the model building codes.

B2 Lateral Force-Resisting System

The objective of the seismic design is to provide a *lateral force-resisting system* that has the available base shear capacity (*available strength*) to meet the required base shear demands (*required strength*) and is detailed in such a manner to provide the ductility and overstrength assumed in the *applicable building code*.

B3 Design Basis

At its simplest level, this *Standard* provides the *available strength* [factored resistance] (base shear capacity) for several different *seismic force-resisting systems* that may be summed to determine the total *available strength* [factored resistance] and then compared against the *required strength* [effect due to factored loads] (base shear demand) from the *applicable building code*. The *available strength* [factored resistance] is determined from the *nominal strength* [nominal resistance] using resistance or safety factors as appropriate.

To achieve the desired ductility and overstrength, the design basis is slightly more complicated. Each *seismic force-resisting system* has within it a *designated energy-dissipating mechanism*. This mechanism must be engaged, and other *limit states* avoided, in the *seismic force-resisting system* for the energy dissipation to occur as intended. To ensure this, the engineer determines the expected [probable] strength of the *energy-dissipating mechanism*, and all other *connections* and *components* in the *seismic force-resisting system* must develop this strength without failure. Thus, the expected strength [probable resistance] of the *designated energy-dissipating mechanism* becomes one possible *required strength* [effect due to factored loads] for all *connections* and *components* in the *seismic force-resisting system* that are not part of the *designated energy-dissipating mechanism*.

In the United States and Mexico: A second possibility is recognized—*connections* and *components* outside of the *energy-dissipating mechanism* do not need to be designed for *required strengths* higher than the seismic load effect including overstrength (Ω_o).

In Canada: A different second possibility is recognized—*Effects due to factored loads* for *connections* and *components* outside of the *energy-dissipating mechanism* do not have to be greater than elastic seismic load effects (i.e. $R_d R_o = 1.0$).

B3.3 Expected Strength [Probable Resistance]

The expected strength [probable resistance] may be expressed as a factor (Ω_E) times the nominal strength.

In the United States and Mexico: In AISI S400-15 an upperbound (conservative) value for $\Omega_E = \Omega_o$ was employed when additional information for determining Ω_E was unavailable, e.g., in Section E1.3.3. In 2016, a more precise upperbound estimate for Ω_E was recognized. At the design limit, $\phi V_n = V_{be}/R$ where V_{be} is the elastic base shear demand. The expected equilibrium between the demand and capacity is $\Omega_o V_{be}/R = V_n + V_o$, where V_o is the lateral resistance of elements outside of the *seismic force-resisting system* (SFERS). Substituting the design limit for V_n and assuming, as an upperbound, that no force is carried outside of the SFERS ($V_o = 0$) results in an upperbound estimate of $\Omega_E = \phi \Omega_o$. This upperbound would appear to reward systems with low ϕ (i.e. highly variable). As an additional check, it is considered that the exceedance probability of the upperbound capacity ($\Omega_E V_n$) should be the same as the lowerbound failure probability, assuming a symmetrical probability distribution.

This implies: $\Omega_E V_n = V_n + (V_n - \phi V_n)$, or $\Omega_E = 2 - \phi$. Thus, an upperbound is established that $\Omega_E = \max(\phi \Omega_o, 2 - \phi)$. This upperbound is applied in this *Standard* when additional information is unavailable for determination of Ω_E .

C. ANALYSIS

C1 Seismic Load Effects

The analysis of *cold-formed steel* systems for seismic response can be complicated due to *connection* flexibility, member cross-section deformations, and significant nonlinearities in hysteretic response of typical *connections*, *components*, and assemblies (e.g., *shear walls*). As a result, typical analysis models are heavily simplified and equivalent lateral force methods detailed in *applicable building codes* are almost exclusively used. Research is ongoing to extend current analysis capabilities and provide reliable nonlinear time history analysis results in the future. Guidance on the use of these methods will be provided in future versions of this *Standard*.

D. GENERAL MEMBER AND CONNECTION DESIGN REQUIREMENTS

No additional requirements regarding member and *connections* are provided in this chapter.

E. SEISMIC FORCE-RESISTING SYSTEMS

Design requirements for *seismic force-resisting systems* defined in the *applicable building code in the United States and Mexico*: ASCE/SEI 7-10 (ASCE, 2010) and *in Canada*: NBCC (NRCC, 2010), are provided in this section of the *Standard*. The seismic performance factors, e.g., the *seismic response modification coefficient*, R , *overstrength factor*, Ω_o , and *deflection amplification factor*, C_d , provided by the *applicable building code* are applicable if the seismic detailing of the associated *seismic force-resisting system* meets the seismic design requirements of this *Standard*.

Seismic design consists of several main steps:

- (1) Proportioning and detailing of the designated *energy-dissipating mechanism* in the seismic force-resisting system (e.g., diagonal strap bracing in strap braced wall systems). Specifically, the nominal strength [resistance] of the seismic force-resisting system is determined, then modified to provide the available strength [factored resistance], which must be greater than the required strength [effect due to factored loads] from the seismic load combination;
- (2) Ensuring ductility, proportioning and detailing of other parts of the *seismic force-resisting system* (e.g., chord studs, *hold-downs* and anchorage in strap braced wall systems) for a *required strength* [effect due to *factored loads*] equal to the expected strength [probable resistance] developed by the designated *energy-dissipating mechanism*; and
- (3) Ensuring a complete load path and system, proportioning and detailing of any other components and connections of the lateral force-resisting system (e.g., *diaphragms*, *collector*, and *chords*), which are in the path of the inertial loads developed by the effective seismic masses of the building and transmitted to the foundation or supporting structural components.

To provide consistency with the outlined seismic design method, the *nominal strength* [resistance] of the *seismic force-resisting systems* in this *Standard* are based on total shear (lateral) strength and not the strength per unit length, as previously provided in AISI S213 (AISI, 2007b). For all *seismic force-resisting systems* defined in this chapter of the *Standard*, a similar design procedure is provided to ensure fulfillment of the seismic design requirement.

E1 Cold-Formed Steel Light Frame Shear Walls Sheathed With Wood Structural Panels

Cold-formed steel framed *shear walls* sheathed with *wood structural panels* are a commonly used *seismic force-resisting system* and provide sufficient lateral shear strength and ductility if properly designed and detailed. This section provides provisions to meet these requirements.

E1.1 Scope

Provisions for *cold-formed steel* framed *shear walls* sheathed with *wood structural panels* are applicable in the United States, Mexico, and Canada.

E1.2 Basis of Design

E1.2.1 Designated Energy-Dissipating Mechanism

Energy-dissipating mechanisms are determined primarily based on test observations and experimental results. Identifying the *energy-dissipating mechanism* in a *seismic force-resisting system* requires substantial knowledge and places important additional requirements on the design of other *components* and *connections* in the *seismic force-resisting system*; e.g., the

chord studs. Cold-formed steel framed shear walls sheathed with wood structural panels experience productive energy dissipation as the connector between the stud and sheathing undergoes tilting and bearing against the wood structural panel.

E1.2.2 Seismic Design Parameters [Seismic Force Modification Factors and Limitations] for Seismic Force-Resisting System

In the United States and Mexico: When the seismic response modification coefficient, R , is not equal to 3, the design must follow the seismic requirements of this *Standard*. When R is equal to 3, the design may follow the requirements of AISI S240 or this *Standard*. Use of AISI S400 requires an applicable building code and referenced load standard. For ASCE/SEI 7 (ASCE, 2010), the design coefficients, factors and limitations assigned to light-framed shear wall systems are reproduced in Table C-E1.2.2. ASCE/SEI 7 also provides limitations based on the *Seismic Design Category*. For *Seismic Design Category A* through *C*, the designer has the option to use an $R = 3$ for systems with a higher assigned R when determining the seismic load. When this is done, the provisions of AISI S240 may be followed and the special detailing in accordance with this *Standard* avoided. For this case, the design coefficients and factors for "Steel Systems Not Specifically Detailed for Seismic Resistance Excluding Cantilever Column Systems" of ASCE/SEI 7 (2010) apply. In *Seismic Design Category D* through *F*, the designer does not have the option to choose an $R = 3$ for systems with a higher assigned R . The design coefficients and factors in Table C-E1.2.2 apply and the provisions of this *Standard* are mandatory. Note, it is never permitted to choose $R = 3$ for systems with a lower assigned R .

In Canada: When $R_d R_o$ is not equal to 2 for sheathed shear walls, this *Standard* is applicable. When $R_d R_o$ is equal to 2 for sheathed shear walls, the AISI S240 standard is adequate. For sheathed shear walls, a designer has the option to choose an $R_d R_o$ of 2 for systems with a higher $R_d R_o$ to determine the seismic load and thereby avoid the special detailing in this *Standard*. For this case, the height limitations for "Other Cold-Formed Steel Seismic Force-Resisting System(s)" in Table 1.2-1 in Appendix 1 of this *Standard* apply.

Table C-E1.2.2^d
United States and Mexico
Design Coefficients and Factors for Shear Walls Sheathed With Wood Structural Panels

Basic Seismic Force-Resisting System ^b	Seismic Response Modification Coefficient, R	System Over-strength Factor, Ω_o ^c	Deflection Amplification Factor, C_d	Structural System Limitations and Building Height (ft) Limitations ^a				
				Seismic Design Category				
				A&B	C	D	E	F
A. BEARING WALL SYSTEMS								
Light-framed walls sheathed with wood structural panels rated for shear resistance	6 ½	3	4	NL	NL	65	65	65
B. BUILDING FRAME SYSTEMS								
Light-framed walls sheathed with wood structural panels rated for shear resistance	7	2 ½	4 ½	NL	NL	65	65	65

^a NL = Not Limited and NP = Not Permitted.

^b Per ASCE/SEI 7 (ASCE, 2010), a bearing wall system is defined as a structural system with bearing walls providing support for all or major portions of the vertical loads, and a building frame system is defined as a structural system with an essentially complete space frame providing support for vertical loads. Per this *Standard*, shear walls are the basic seismic force-resisting elements.

^c The tabulated value of the overstrength factor, Ω_o , is permitted to be reduced by subtracting one-half for structures with flexible *diaphragms*, but shall not be taken as less than 2.0 for any structure.

^d See ASCE/SEI 7 (ASCE, 2010) Table 12.2-1 for additional footnotes.

For SI: 1 ft = 0.305 m

E1.2.3 Type I or Type II Shear Walls

Type I shear walls are fully sheathed with wood structural panels and with hold-downs and anchorage at each end. For example, Figure C-E1.2.3-1(a) is an example of a wall with two *Type I shear walls*. This form of detailing is the most common for *Type I shear walls*. *Type I shear walls* are permitted to have openings when details are provided to account for force transfer around the openings, as depicted in C-E1.2.3-1(b). See additional commentary in AISI S240.

Type II shear walls sheathed with wood structural panels are permitted to have openings between the ends (*chord studs* with hold-downs and anchorage); however, the width of such openings should not be included in the length of the *Type II shear wall* and the openings do not have to be detailed for force transfer, as depicted in Figure C-E1.2.3-2.

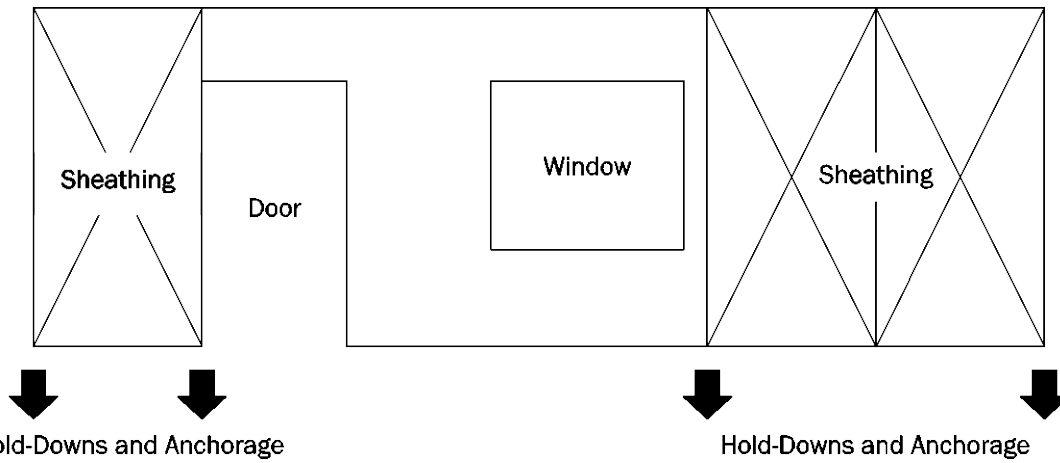

Figure C-E1.2.3-1(a) – Type I Shear Walls Without Detailing for Force Transfer Around Openings

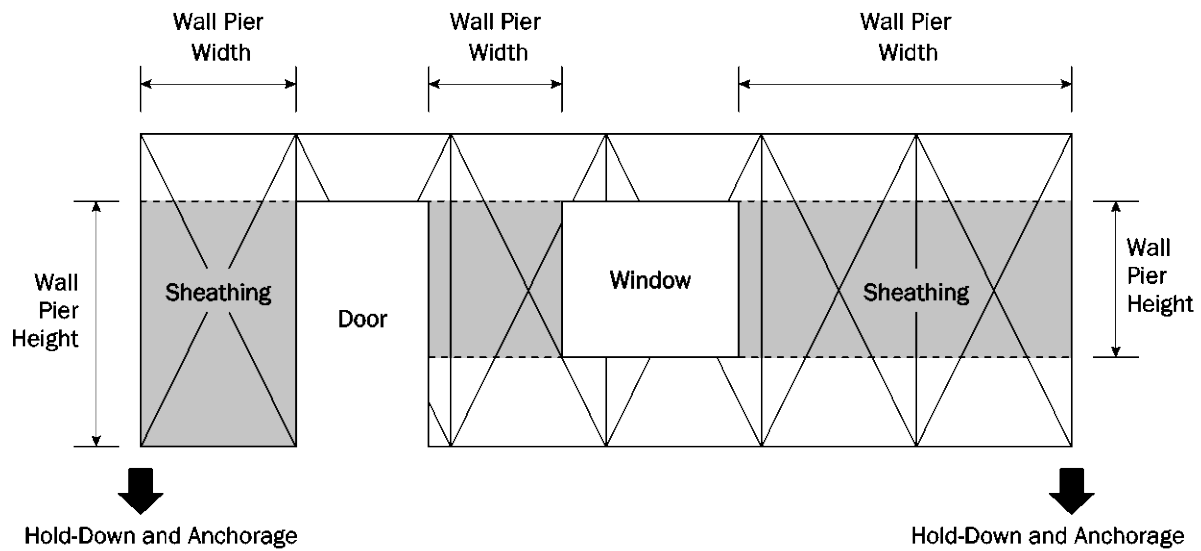

Figure C-E1.2.3-1(b) – Type I Shear Wall With Detailing for Force Transfer Around Openings

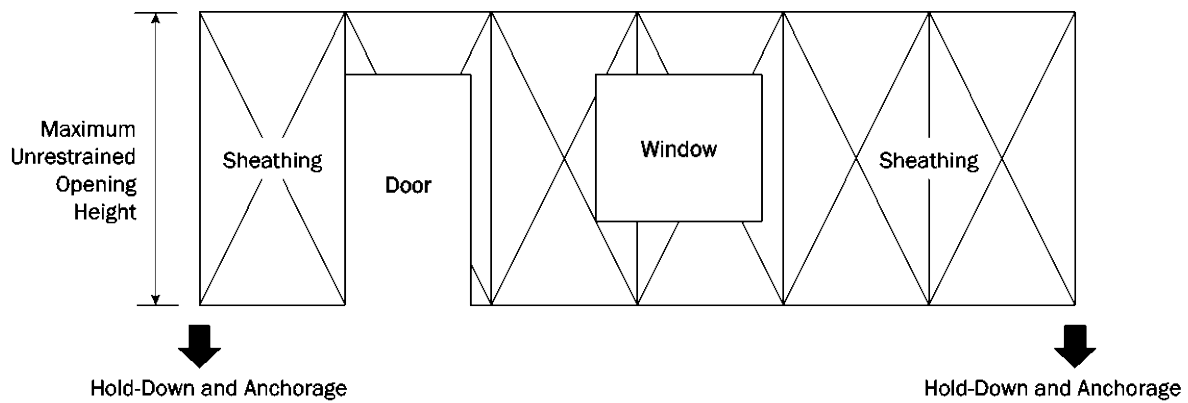

Figure C-E1.2.3-2 – Typical Type II Shear Wall

E1.2.4 Seismic Load Effects Contributed by Masonry and Concrete Walls

For general commentary on seismic *load* effects contributed by masonry and concrete walls, see Section B1.4.

E1.3 Shear Strength [Resistance]

E1.3.1 Nominal Strength [Resistance]

E1.3.1.1 Type I Shear Walls

The *nominal strength [resistance]* of the wall in shear is determined by multiplying the length of the wall by the tested wall capacity per length of wall. For narrow walls with aspect ratios greater than 2 and less than or equal to 4, an additional reduction is applied consistent with test observations for narrow aspect ratio walls (Serrette, 1997). The tested shear wall capacity is based on an estimate of degraded strength under cyclic *shear wall* tests. Details of this estimate are different for the United States (and Mexico) and Canada. Since the tabulated values in this *Standard* are based on test data, it was deemed necessary to provide the user with the limiting values of the tested systems. The intent is not to prevent an engineer from using judgment, the principles of mechanics, and supplemental data to develop alternate shear values from those shown in this *Standard*, as discussed in Section A.

In the United States and Mexico: *Shear wall* tests were conducted to the Sequential Phase Displacement (SPD) protocol and strength was determined from a degraded (secondary) cycle of the wall strength envelope. The initial tests were conducted by Serrette (1996, 1997 and 2002) and included reverse cyclic and monotonic *loading* for plywood, oriented strand board, and gypsum wall-board *shear wall* assemblies. The basic reversed cyclic test protocol used is illustrated in Figure C-E1.3.1-1, and is known as the Sequential Phase Displacement or (SPD) protocol. Typical hysteretic response and typical peak and degraded strength envelopes are illustrated in Figure C-E1.3.1-2. The degraded wall strength is the set of points describing the peak strength associated with the second cyclic of a target (repeated) input displacement. *Nominal strength* of a tested wall was defined as the smaller one of the maximum strength and 2.5 times the strength at 0.5 in. of lateral displacement. The 0.5 in. displacement was based on the *allowable strength* drift limit for an 8-ft wall in accordance with the 1994 Uniform Building Code (ICBO, 1994), which was the code in effect at the time this information was first proposed for acceptance in a building code. Typically, the degraded maximum strength controlled.

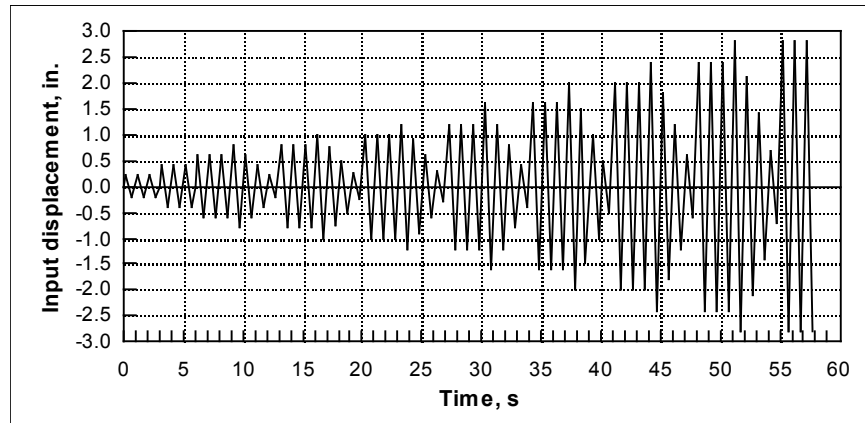

Figure C-E1.3.1-1 – Reverse Cyclic Test Protocol (1.0 Hz)

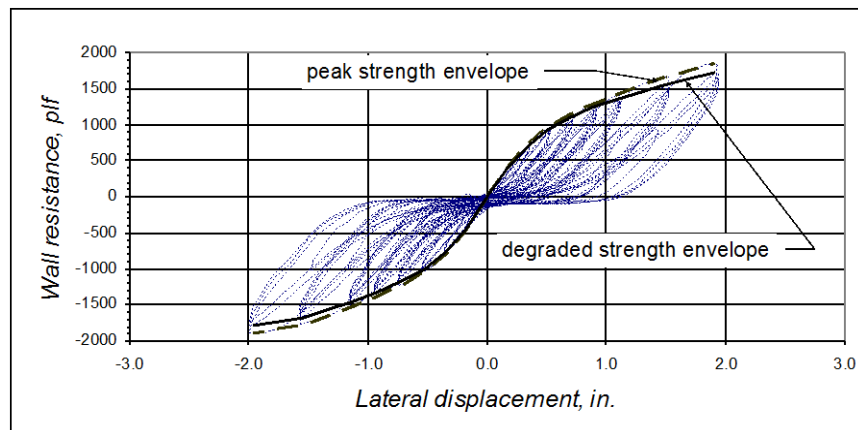

Figure C-E1.3.1-2 – Hysteretic Response Plot Showing Peak and Degraded Strength Envelopes

In Canada: Shear wall tests were conducted to the CUREE protocol and strength was determined from an equivalent energy elastic-plastic (EEEP) analysis of the cyclic wall strength envelope curve. The test program of single-story laterally loaded shear walls constructed of Canadian sheathing products was initiated by Branston et al. (2006b). Based on the data obtained from this test program, as well as the wall behavior/performance that was observed (Chen et al., 2006), a design method was developed (Branston, 2006a). Shear resistance values for additional wall configurations have been provided by Boudreault (2005), Blais (2006), Rokas (2006) and Hikita (2006). Monotonic testing (Figure C-E1.3.1-3(a)) was carried out, along with reversed cyclic testing, in which the CUREE protocol for ordinary ground motions (Figure C-E1.3.1-4) (Krawinkler et al., 2000; ASTM E2126 2005) was used for the majority of wall specimens (Boudreault, 2005). A typical shear resistance vs. displacement hysteresis for a reversed cyclic test is provided in Figure C-E1.3.1-3(b). Nominal resistance values for wood sheathed shear walls were obtained from the test data using the equivalent energy elastic-plastic (EEEP) analysis approach (Figure C-E1.3.1-5). The concept of equivalent energy was first proposed by Park (1989) and then presented in a modified form by Foliente (1996). A codified version of the equivalent energy elastic-plastic (EEEP) approach to calculating the design parameters of light-framed shear walls can also be found in ASTM E2126 (2005).

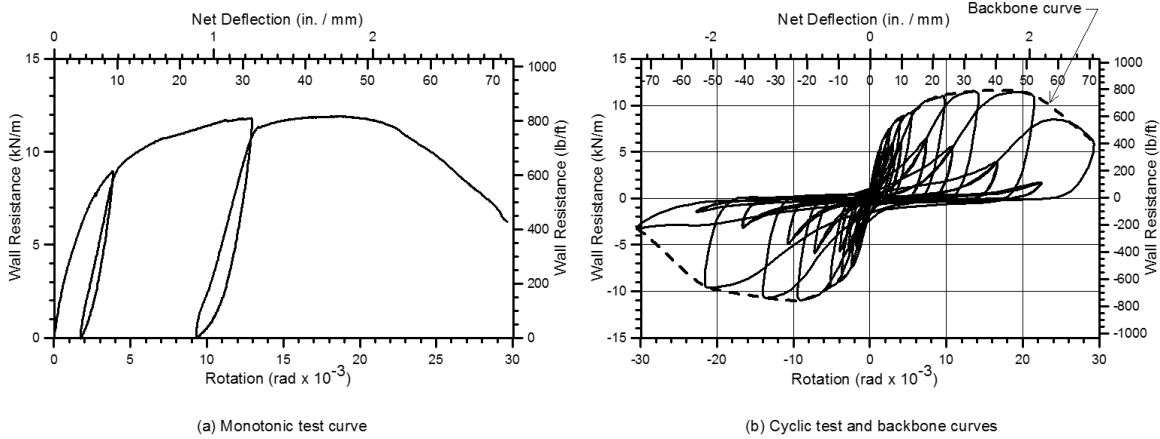

Figure C-E1.3.1-3 – Force–Deformation Response of Typical Monotonic and Reversed Cyclic Tests

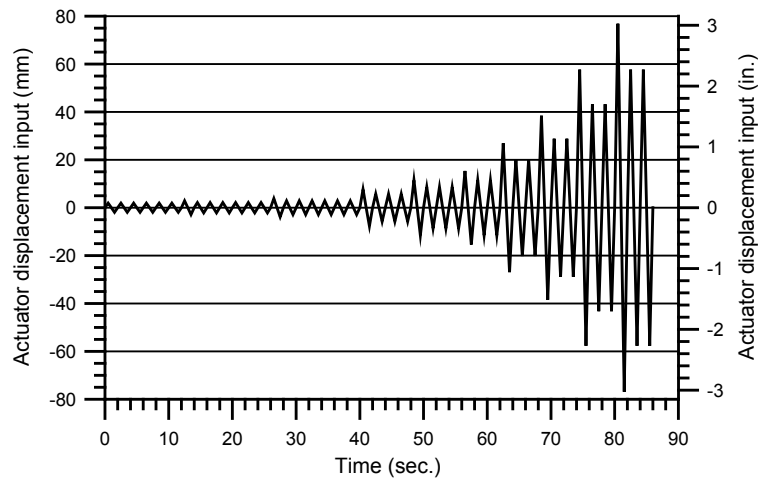

Figure C-E1.3.1-4 – CUREE Reversed Cyclic Test Protocol (0.5 Hz)

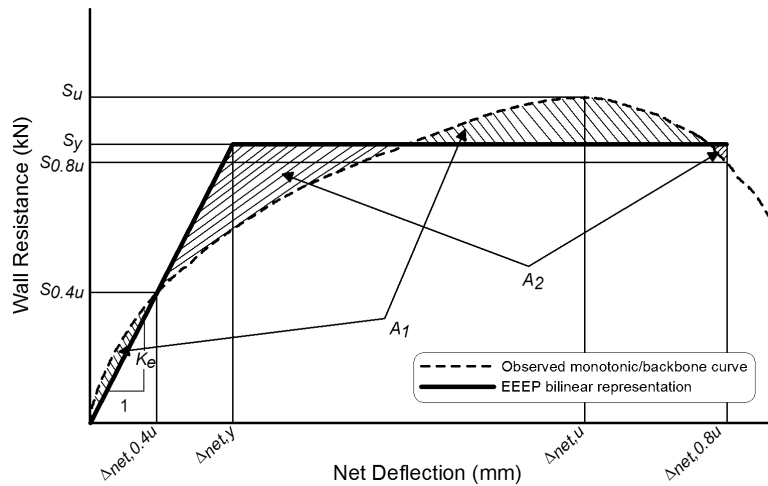

Figure C-E1.3.1-5 – Equivalent Energy Elastic-Plastic (EEEP) Analysis Model

In Canada: In the case of each reversed cyclic test, a backbone curve was first constructed for both the positive and negative displacement ranges of the resistance vs.

deflection hysteresis. This backbone curve represents the outer envelope of the first loading cycles in the CUREE protocol. The resistance vs. deflection curve for monotonic specimens and the backbone curves for cyclic tests were used to create EEEP curves based on the equivalent energy approach, as illustrated in Figure C-E1.3.1-6. The resulting plastic portion of the bilinear curve was defined as the nominal resistance. The 2005 NBCC also requires that for seismic design, lateral inelastic deflections be limited to 2.5% of the story height for buildings of normal importance. A limit of 2.5% drift was also used in the energy balance (Branston et al., 2006b). When this inelastic drift limit was incorporated, it had the effect of lowering the recommended *nominal resistance*. A typical series of tests (monotonic and backbone) and EEEP curves for a wall configuration is shown in Figure C-E1.3.1-7. Since the CUREE reversed cyclic protocol for ordinary ground motions produces results that are very similar to those revealed by a monotonic test for an identical wall configuration (Chen, 2004; Chen et al., 2006), it was decided that the results for the monotonic tests and the reversed cyclic tests would be combined to produce a minimum of six nominal shear values for each wall configuration. The recommended *nominal resistance* of the steel frame/wood panel *shear walls* was initially developed based on the mean value of the monotonic and reversed cyclic test data for a particular wall configuration. A reduction factor was then determined from the assumed normal statistical distribution of test-to-predicted (mean) results, which made it possible to recommend the fifth percentile results that are tabulated in the *Standard*. Use of the fifth percentile approach to determine nominal shear strengths resulted in an average *ASD safety factor* of 2.67 (Branston et al., 2006a).

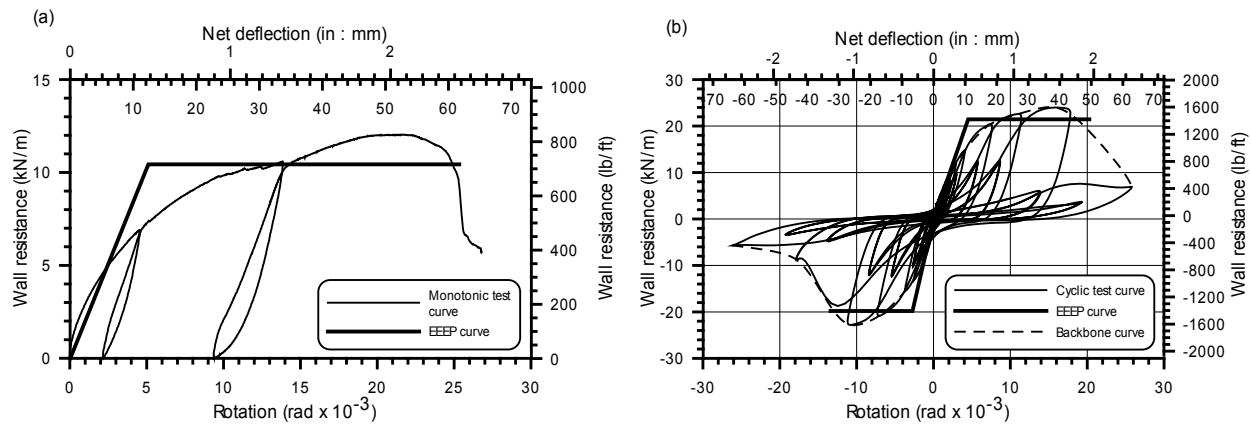

Figure C-E1.3.1-6 – Typical Test and EEEP Curves: (a) Monotonic; (b) Reversed Cyclic

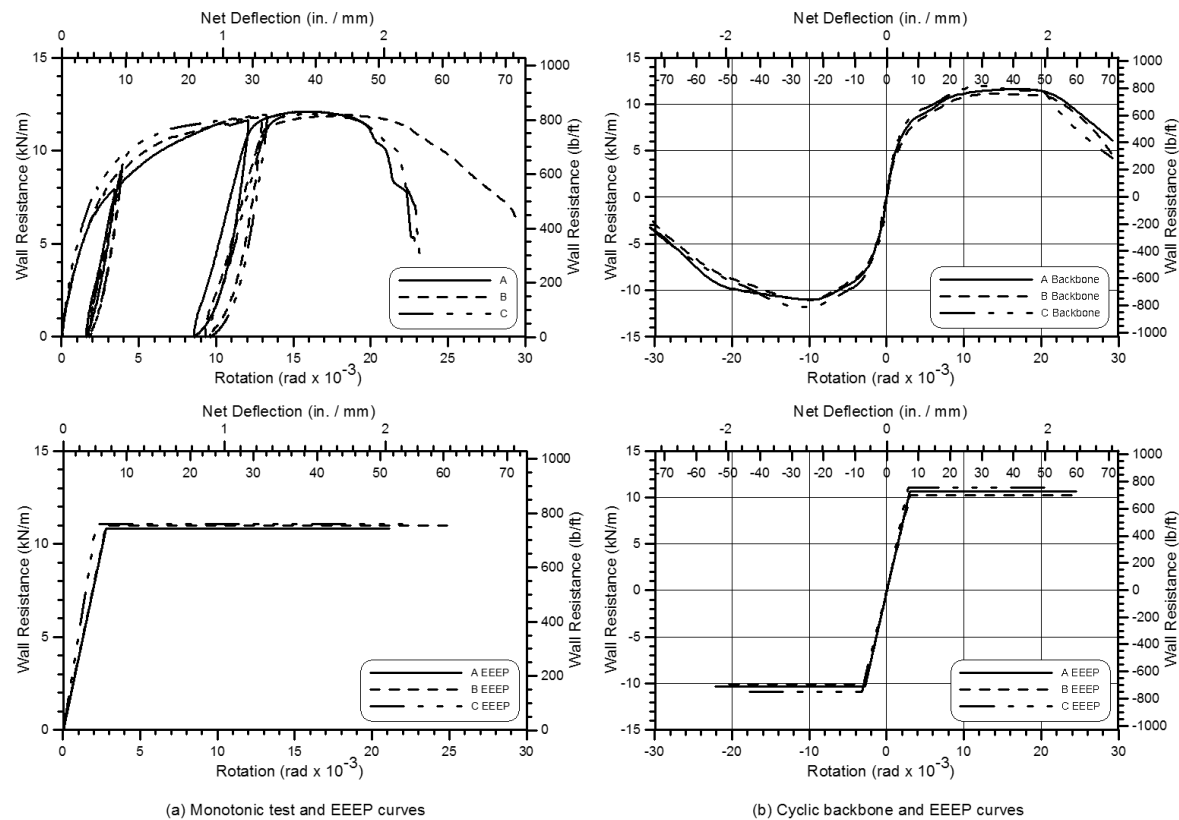

Figure C-E1.3.1-7– Typical Series of Test and EEEP Curves for Monotonic and Reversed Cyclic Tests

Since the *shear wall* tests were carried out over a short time span, the tabulated values are for short-term duration *loads*, including earthquake (and wind). In general, wood products exhibit a decreased resistance to long-term *loads*, and hence the shear resistance should be decreased accordingly for standard and permanent *loads*. ***In the United States and Mexico***, it is recommended to follow NDS, e.g., the 2015 NDS (AFPA, 2015); and ***in Canada***, CSA O86 (CSA, 2001).

A *shear wall* assembly using an *approved* adhesive to attach *shear wall* sheathing to the framing is not yet recognized by this *Standard* or by ASCE/SEI 7. Sufficient test data to justify acceptance of *shear walls* that use adhesive alone or in combination with fasteners to attach sheathing to the framing members was not available at the time this *Standard* was written. The limited existing test data indicates that *shear walls* using adhesives for sheathing attachment will generally not perform the same as *shear walls* with only fasteners attaching the sheathing to the framing (Serrette, 2006).

All provided *shear wall* capacities are based on testing. System requirements consistent with the conducted testing are detailed in Section E1.4 and flagged in the notes of the shear capacity Table E1.3-1. Due to the prescriptive nature of the tabulated shear values, care must be taken to follow the complete requirements to ensure the *designated energy-dissipating mechanism* is initiated in the system.

E1.3.1.1.1 Wall Pier Limitations

The requirement for the minimum length of a wall pier is considered consistent with the available test data and maximum h_p/w_p criterion ($h_p/w_p \leq 2$). For a typical story height of 8 ft (2440 mm) and about 50% full-height sheathing, the minimum

allowable length of the wall is 24 inches (610 mm), which is a typical distance used to place studs. The structural behavior of narrow wall piers can induce significant bending in the *chord studs* and other changes that result in *limit states* not anticipated in this *Standard*. Further, narrow wall piers may provide a reduced lateral stiffness that leads to deformation incompatibilities, and at a minimum more rigorous analysis of the wall to understand force transfer would be required.

E1.3.1.1.2 Both Wall Faces Sheathed With the Same Material and Fastener Spacing

Per Section E1.2.1 of the *Standard*, connections between the *wood structural panel* sheathing and the *cold-formed steel structural members* are the primary *energy-dissipating mechanism* in sheathed *shear walls*. Employing the same material and fastener spacing on both faces of the wall doubles the number of fasteners and accordingly the *nominal strength* [resistance] of the wall in the *seismic force-resisting system*. However, increasing the *nominal strength* [resistance] increases the expected strength [probable resistance] of the *shear wall* developed by the *designated energy-dissipating mechanism*. Accordingly, other components of the *seismic force-resisting system*, i.e., *chord studs*, *hold-downs* and anchorage, should be able to carry the applied load determined based on the expected strength [probable resistance] of the *shear wall*.

E1.3.1.1.3 More Than a Single Sheathing Material or Fastener Configuration

While no extensive experimental results are available to provide a definitive *nominal strength* [resistance] for different combinations of material sheathing, a conservative *limit state* design method is adopted as follows.

Different types of *shear wall* sheathing and fastener spacing can provide different nonlinear behavior and nonlinear deformation capacity for *shear walls*. While both sides of the wall will experience the same lateral deformation demand, superimposing *nominal strength* [resistance] provided by each individual face is not valid. Accordingly, a *limit state* method is provided in this *Standard* to account for different sheathings and fastener spacing of the *shear wall* faces. Correspondingly, two scenarios are considered. In the first scenario, the weaker material fails first while the stronger is still working. In this case it is reasonable to assume the stronger side can at least provide a capacity equal to the weaker part, and the total *shear wall* capacity can be determined assuming the weaker (lower *nominal strength* [resistance]) material or fastener configuration exists for the whole wall. In the other scenario, the weaker side of the wall fails earlier and the stronger side carries over the redistributed load until failure. If the failure load of the stronger side is larger than the capacity determined in the first scenario, this failure load can be taken as the *shear wall* capacity. Otherwise, the shear capacity of the wall will be the capacity determined based on the assumption that the weaker material is on both sides of the wall.

Although the provided solution is conservative from a *nominal strength* [resistance] standpoint, it may not be conservative to utilize this method in calculating expected strength [probable resistance] of the *shear wall*. Based on engineering judgment, the sum of the strength of the two dissimilar wall sheathing materials or fastener spacings is a reasonable upperbound estimate. This summed strength should be converted to expected strength based on observed bias, or in the absence of data, in the United States and Mexico using Ω_o , and in Canada using elastic ($R_d R_o = 1$) force

levels.

Using multiple layers of sheathing on one side of the *shear wall* can substantially change the failure mode of the sheathing connectors. However, this effect has not been studied extensively to date. Accounting for only the innermost layer when determining the strength is assumed to be conservative.

E1.3.1.2 Type II Shear Walls

The requirements for *Type II shear walls*, also known as perforated *shear walls*, in Section E1.2.3 are based on provisions in NEHRP (2000) for wood systems. In this method, the shear capacity ratio, F , or the ratio of the strength of a *shear wall* segment with openings to the strength of a fully sheathed wall segment without openings, is determined as follows:

$$F = \frac{r}{3 - 2r} \quad (\text{Eq. C-E1.3.1.2-1})$$

where

$$r = \frac{1}{1 + \frac{A_0}{h \sum L_i}} \quad (\text{Eq. C-E1.3.1.2-2})$$

A_0 = Total area of openings

h = Height of wall

$\sum L_i$ = Sum of the length of full-height sheathing

Research by Dolan (1999, 2000a, 2000b) demonstrated that this design procedure is as valid for steel-framed systems as for all wood systems, and the IBC (ICC, 2003) and NFPA 5000 (NFPA, 2003) building codes both permit the use of *Type II shear walls* for steel-framed systems. Test results revealed the conservative nature of predictions of capacity at all levels of monotonic and cyclic *loading*. The *Standard* does not provide a method or adjustment factor for estimating the lateral displacement of *Type II shear walls*. As such, the user should be cautious if a *Type II shear wall* is used in a deflection-sensitive design.

Table E1.3.1.2-1 in the *Standard*, which establishes an adjustment factor for the shear resistance, is based on the methodology described in this section and exists in essentially the same form in both the wood and steel chapters of the IBC (ICC, 2003). There is also a similar table in AISI S230 (AISI, 2012b); however, AISI S230 establishes an adjustment factor for the *shear wall* length rather than the *shear wall* resistance.

In accordance with *Standard* Section E1.3.1.1, it is required to check the aspect ratio (h/w) of each *Type II shear wall segment* and reduce the strength of each segment that has an aspect ratio greater than 2:1, but less than or equal to 4:1 by the factor of $2w/h$. This aspect ratio reduction factor is cumulative with the shear resistance adjustment factor, C_a .

E1.3.2 Available Strength [Factored Resistance]

AISI S100 provides a summary of the first order reliability method used for determining *limit states*-based safety (Ω) and resistance (ϕ) factors. *In the United States and Mexico*: The *shear wall* safety factor (Ω) was based on successful past practice with

diaphragms and engineering judgment. Conversion from Ω to ϕ was based on expressions provided in Chapter F of AISI S100 (AISI, 2012). The *safety* and *resistance factors* for steel sheathed *shear walls* were developed based on the research by Yu (2007). **In Canada:** A *resistance factor* (ϕ) was calibrated according to the *LSD (Limit States Design)* procedures prescribed in the 2005 NBCC (the procedure is nearly identical to AISI S100 Chapter F). A reliability index, β_o , of 2.5 was used because the recommended nominal design resistances are not the ultimate capacity of the test walls (Fig. C-E1.3.1-6). A ϕ of 0.7 was obtained for 2005 NBCC wind forces, and it is recommended that the same ϕ be used in seismic design. This value was used by Boudreault et al. (2007) in the calculation of R_o . The *resistance factor* for steel *sheathed shear walls* was developed by Balh et al. (2014) and DaBreo et al. (2014).

E1.3.3 Expected Strength [Probable Resistance]

This *Standard* incorporates a *capacity-based design* approach in which an element (fuse) of the *seismic force-resisting system* of a structure is designed to dissipate energy. The fuse element, known as the *designated energy-dissipating mechanism*, must be able to carry seismic loads over extensive inelastic displacements without sudden failure. It is expected that the fuse element will fail in a ductile, stable and predictable manner, at which time it will reach and maintain its maximum load-carrying resistance. In a structure that makes use of *cold-formed steel framed shear walls with wood structural panels* as lateral force-resisting elements, the *shear walls* themselves can initially be thought of as the fuse elements in the larger *lateral force-resisting system*. More specifically, it is the sheathing-to-steel framing *connections* of the *shear wall* that have been shown to fail in a ductile fashion and hence, it is these *connections* that are the *designated energy-dissipating mechanism* – i.e., the fuse. Thus, we seek the expected strength of this mechanism so that it can be protected.

The *capacity-based design* approach stipulates that all other *components* and *connections* in the lateral load-carrying path must be designed to withstand the expected [probable] strength of the *designated energy-dissipating mechanism* (fuse) element, where the expected strength takes into account expected overstrength (strength above nominal) that may exist. In the case of a *cold-formed steel framed shear wall*, the *system* includes the *chord studs*, field *studs*, *hold-down* and anchorage, *track*, etc.; these *components* are designed to carry the expected [probable] strength of the *shear wall* while the sheathing-to-framing *connections* fail in a ductile manner. To design the *chord studs* and other *components* of the *seismic force-resisting system*, it is necessary to estimate the probable capacity of the *shear wall* based on a sheathing *connection* failure mode. This can be achieved by applying an overstrength factor to the *nominal resistance* (Figure C-E1.3.3-1).

In the United States and Mexico: It should be noted that the *nominal strengths* shown in Table E1.3-1 are based on a degraded backbone curve determined using the SPD cyclic protocol (Figure C-E1.3.1-1). Testing of similar specimens with the SPD and CUREE cyclic protocol were 20 percent higher using the CUREE cyclic protocol (Boudreault, 2005). Thus, expected strengths in the United States and Mexico are at least 1.2 times v_n in Table E1.3-1. However, no additional analysis has been conducted for finding expected strength. As a result, the upperbound estimate introduced in *Commentary* Section B3.3 is employed: $\Omega_E = \max(\phi\Omega_o, 2 - \phi)$. For this system, $\phi = 0.6$, and based on ASCE/SEI 7-10, $\Omega_o = 3$ for bearing wall systems and 2.5 for building frame systems, resulting in $\Omega_E = 1.8$.

In Canada: Comparison of the ultimate test shear resistance with the recommended fifth percentile nominal design resistance provided justification for an overstrength factor

of 1.33 for walls sheathed with DFP and OSB, and 1.45 for walls sheathed with CSP panels. Initial selection of the *shear wall* to resist the expected NBCC seismic base shear should be based on a *factored resistance*; i.e., the overstrength factor should not be included during wall selection. The probable capacity is only used to estimate the forces in the design of the non-fuse elements of the *seismic force-resisting system*.

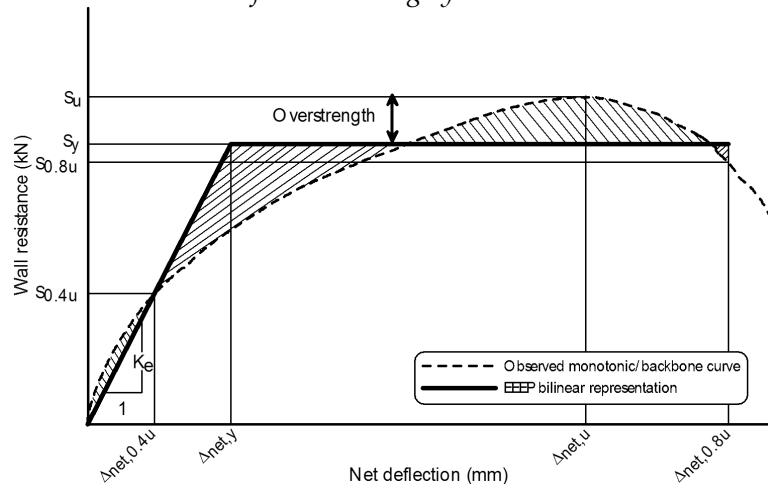

Figure C-E1.3.3-1 – Overstrength in Design

Investigations into the effect of combined gravity and lateral loads on *shear wall* performance by Hikita (2006) have shown that the addition of gravity loads does not change the lateral performance characteristics of a steel frame/wood panel *shear wall* if the selection of the *chord studs* is appropriate; i.e., the *chord studs* are designed to resist the compression forces due to gravity loads in combination with the forces associated with the expected [probable] ultimate shear strength [capacity] of the wall as controlled by sheathing *connection* failure.

E1.4 System Requirements

The system requirements detailed in Section E1.4 are necessary for the *seismic force-resisting system* to develop the desired strength and ductility, as demonstrated through testing. The provisions are a combination of prescriptive recreations of the physically tested specimens and engineering judgment with respect to potential and practical substitutions. Wherever possible, this *Standard* has tried to provide appropriate minimum (or maximum) conditions instead of direct prescriptions. An engineer should be aware that if they deviate significantly from suggested values, behavior may diverge from the desired as well.

E1.4.1 Type I Shear Walls

E1.4.1.1 Limitations for Tabulated Systems

Limitations (a) to (r) should be met for systems utilizing the tabulated shear capacity of Table E1.3-1. Substitutions are subject to the provisions of Chapter H or more generally the rational analysis clause of Chapter A (Section A1.2.5).

It is important to note that Table E1.3-1 designates the *chord stud* thickness and minimum fastener size. Per Note 5 of Table E1.3-1, thicker studs are not allowed unless specified in the table – this is to avoid screw shear *limit states* that become common when thicker stud materials are employed.

Overdriving of the sheathing screws will result in reduced performance of a *shear wall* compared with the values obtained from testing (Rokas, 2006); hence, sheathing screws should be firmly driven into framing members but not overdriven into sheathing. Bugle, wafer and flat head screws should be driven flush with the surface of the sheathing; pan head, round head, and hex-washer head screws should be driven with the bottom of the head flush with the sheathing.

E1.4.1.2 Required Strength [Effect Due to Factored Loads] for Chord Studs, Anchorage, and Collectors

In the United States and Mexico: Section 12.10.2.1 of ASCE/SEI 7 (ASCE, 2010) exempts structures or portions thereof that are braced entirely by light-frame *shear walls* from the requirement to have *collectors*, *splices*, and *connections* to resisting *components* designed to resist *amplified seismic loads*. Nevertheless, to develop a desirable response, this *Standard* requires that *connections* for *boundary elements* transferring load to and from the *shear wall* be capable of developing the expected [probable] strength of the *shear wall*. In the U.S. and Mexico, this includes *collectors*, *chord studs* or other vertical *boundary elements*, *hold-downs* and anchorage connected thereto, sill plate shear anchors, and all other components and *connections* of the *shear wall* that are not part of the designated *energy-dissipating mechanism*. *Diaphragms* are not required to be designed for the *shear wall* expected strength. The expected [probable] strength for *shear walls* with *wood structural panels* is, as of 2014, estimated as the *nominal strength* [resistance] amplified by the *system overstrength factor*, Ω_o ; thus, this *Standard* does require *amplified seismic loads* to be considered for these *components*. This requirement is applicable to *splices* in *track* that serves as a *boundary element*.

E1.4.1.3 Required Strength [Effect Due to Factored Loads] for Foundations

In the United States and Mexico: Foundation design does not strictly follow a *capacity-based design* methodology. Per ASCE/SEI 7 (ASCE, 2010), requirements for detached one- and two-family dwellings of light-frame construction not exceeding two stories above grade plane assigned to *Seismic Design Category* D, E, or F are modified and need only comply with the requirements for ASCE/SEI 7-10 Sections 11.8.2, 11.8.3 (Items 2 through 4), 12.13.2, and 12.13.5.

E1.4.1.4 Design Deflection

The deflection provisions are based on work performed by Serrette and Chau (2003). Equation E1.4.1.4-1 may be used to estimate the drift deflection of *cold-formed steel* light-framed *shear walls* recognized in the building codes. The equation should not be used beyond the *nominal strength* [resistance] values given in the *Standard*. The method is based on a simple model for the behavior of *shear walls* and incorporates empirical factors to account for inelastic behavior and effective shear in the sheathing material. Specifically, the model assumes that the lateral deflection (drift) of a wall results from four basic contributions: linear elastic cantilever bending (*boundary element* contribution), linear elastic sheathing shear, a contribution for overall nonlinear effects and a lateral contribution from *hold-down* and anchorage deformation. These four contributions are additive.

$$\delta = \frac{2vh^3}{3E_s A_c b} + \omega_1 \omega_2 \frac{vh}{\rho G t_{\text{sheathing}}} + \omega_1^{5/4} \omega_2 \omega_3 \omega_4 \left(\frac{v}{\beta}\right)^2 + \frac{h}{b} \delta_v \quad (\text{Eq. C-E1.4.1.4-1})$$

$$\text{Linear elastic cantilever bending: } \frac{2vh^3}{3E_s A_c b} \quad (\text{Eq. C-E1.4.1.4-2})$$

$$\text{Linear elastic sheathing shear: } \omega_1 \omega_2 \frac{vh}{\rho G t_{\text{sheathing}}} \quad (\text{Eq. C-E1.4.1.4-3})$$

$$\text{Overall nonlinear effects: } \omega_1^{5/4} \omega_2 \omega_3 \omega_4 \left(\frac{v}{\beta}\right)^2 \quad (\text{Eq. C-E1.4.1.4-4})$$

$$\text{Lateral contribution from } \textit{hold-down} \text{ and anchorage deformation: } \frac{h}{b} \delta_v \quad (\text{Eq. C-E1.4.1.4-5})$$

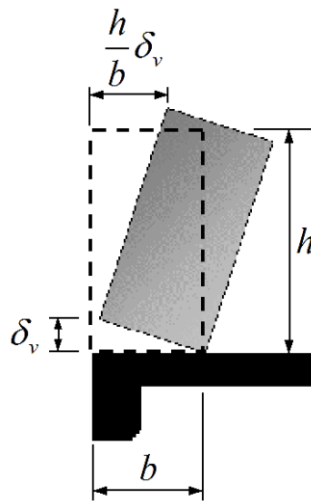

Figure C-E1.4.1.4-1 – Lateral Contribution From Hold-Down and Anchorage Deformation

The lateral contribution from *hold-down* and anchorage deformation is dependent on the aspect ratio of the wall, as illustrated in Figure C-E1.4.1.4-1. The empirical factors used in the equation are based on regression and interpolation analyses of the reversed cyclic test data used in development of the *cold-formed steel shear wall* design values. The ρ term in the linear elastic sheathing shear expression attempts to account for observed differences in the response of walls with similar framing, fasteners and fastener schedules, but different sheathing material. The equations were based on *Type I shear walls* without openings, and the user should use with caution if applying them to *Type I shear walls* with openings. The *shear wall* deflection equations do not account for additional deflections that may result from other *components* in a structure (for example, wood sills and raised floors).

For *wood structural panels*, the shear modulus, G , is not a readily available value, except for Structural I plywood panels in the IBC (ICC, 2003) and UBC (ICBO, 1997) codes. However, the shear modulus may be approximated from the through-thickness-shear rigidity ($G_v t_v$), the nominal panel thickness (t) and through-thickness panel grade and construction adjustment factor (C_G) provided in the *Manual for Engineered Wood Construction* (AFPA, 2001). For example, G for 7/16-in. 24/16 OSB rated sheathing can be approximated as follows:

$G_v t_v$ (24/16 span rating) = 25,000 lb/inch (strength axis parallel to framing)

$t = 0.437$ inch (as an approximation for t_v)

$C_G = 3.1$

G (approximate) = $3.1 \times 25,000 / 0.437 = 177,300$ psi

Thus, $C_G G_v t_v = 77,500$ lb/inch and $Gt = 77,500$ lb/inch

A comparison of the $C_G G_v t_v$ and Gt values suggests that using the nominal panel thickness as an approximation to t_v is reasonable, given that the deflection equation provides an estimate of drift.

In 2009, *Standard* Equation E1.4.1.4-1 for determining the deflection of a blocked *wood structural panel* was consolidated for U.S. Customary and SI Units in AISI S213, a precursor to this *Standard*.

In 2012, in AISI S213, coefficients β and ρ in deflection Equation C-E1.4.1.4-1 were revised for Canadian Soft Plywood (CSP), based on research results compiled by Cobeen (2010). CSP was differentiated from other plywoods based on the performance of that material. Note that Canadian Douglas Fir Plywood (DFP) was found to behave similarly to plywood in common use in the United States.

E1.4.2 Type II Shear Walls

E1.4.2.1 Additional Limitations

Type II shear walls must meet all the requirements of *Type I shear walls* and the additional requirements provided in this section. If the *Type II shear wall* has non-uniform height or other complexities, the simplified approach provided in this *Standard* may not be adequate. See Dolan (1999, 2000a, 2000b) for more information.

E1.4.2.2 Required Strength [Effect Due to Factored Loads] for Chord Studs, Anchorage, and Collectors

Design of *chord studs*, anchorage and *collectors* for *Type II shear walls* follows the same philosophy as *Type I shear walls*. See the commentary for Section E1.4.1.2.

E1.4.2.2.1 Collectors Connecting In-Plane Type II Shear Wall Segments

Type II shear wall segments are designed as *Type I shear walls*, and thus the *designated energy-dissipating mechanism* is within the *Type II shear wall* segment. Therefore, *collectors* connecting in-plane *Type II shear wall* segments must be designed for the expected [probable] strength of the segments to protect the *designated energy-dissipating mechanism*.

E1.4.2.2.2 Uplift Anchorage and Boundary Chord Forces at Type II Shear Wall Ends

Uplift anchorage (*hold-downs* and anchorage) and *chord studs* are outside of the *designated energy-dissipating mechanism* and thus should be designed for the expected [probable] strength of the *designated energy-dissipating mechanism* to ensure ductility in the *seismic force-resisting system*.

E1.4.2.2.3 Uplift Anchorage Between Type II Shear Wall Ends

The *Standard* requires that equilibrium be maintained between anchorage and *collectors* between *Type II shear wall* segments; therefore, the collected shear in these

segments must also be accounted for in the anchorage design of the same segments.

E1.4.2.3 Design Deflection

Prescriptive equations for the deflection of *Type II shear walls* are not provided in the *Standard*. Care should be taken if attempts are made to extend the method of Section E1.4.1.4. The largest contribution to deflection in the Section E1.4.1.4 method is the empirical nonlinear “ ρ ” term and the modification of this value for *Type II shear wall* segments is unknown. In addition, actual deflections include friction, *bearing*, slip, and a variety of mechanisms that are difficult to account for without at least partial experimental calibration.

E2 Cold-Formed Steel Light Frame Shear Walls With Steel Sheet Sheathing

Cold-formed steel framed shear walls with steel sheet sheathing can provide adequate lateral shear strength and ductility if properly designed and detailed. This section provides provisions to meet these requirements. The organization is identical to *shear walls with wood structural panels* as presented in the *Standard* and *Commentary* of Section E1. This section largely parallels the Section E1 presentation, and the engineer is recommended to read the full Section E1 commentary in addition to this section.

E2.2 Basis of Design

E2.2.1 Designated Energy -Dissipating Mechanism

Ductility in steel sheet *shear walls* results from *bearing* deformations at the stud-to-steel sheet *connections* and yielding in the tension fields that develop across the steel sheet between and perpendicular to buckled portions of the steel sheet(s). Thickness and yield stress of the sheet are critical for this mechanism and both are prescribed in the *Standard*.

E2.2.2 Seismic Design Parameters [Seismic Force Modification Factors and Limitations] for Seismic Force-Resisting System

The commentary of Section E1.2.2 is applicable to the *cold-formed steel shear walls* with *steel sheet sheathing* by superseding Table C-E1.2.2 with Table C-E2.2.2 for the seismic design parameters.

Table C-E2.2.2^d
United States and Mexico
Design Coefficients and Factors for Shear Walls Sheathed With Steel Sheet Sheathing

Basic Seismic Force-Resisting System ^b	Seismic Response Modification Coefficient, R	System Over-strength Factor, Ω_0 ^c	Deflection Amplification Factor, C_d	Structural System Limitations and Building Height (ft) Limitations ^a				
				Seismic Design Category				
				A&B	C	D	E	F
A. Bearing Wall Systems								
Light-framed walls sheathed with steel sheets	6 ½	3	4	NL	NL	65	65	65
B. Building Frame Systems								
Light-framed walls sheathed with steel sheets	7	2 ½	4 ½	NL	NL	65	65	65

^a NL = Not Limited and NP = Not Permitted.

^b Per ASCE/SEI 7 (ASCE, 2010), a bearing wall system is defined as a structural system with bearing walls providing support for all or major portions of the vertical loads, and a building frame system is defined as a structural system with an essentially complete space frame providing support for vertical loads. Per this *Standard*, shear walls are the basic seismic force-resisting elements.

^c The tabulated value of the overstrength factor, Ω_0 , is permitted to be reduced by subtracting one-half for structures with flexible *diaphragms*, but shall not be taken as less than 2.0 for any structure.

^d See ASCE/SEI 7 (ASCE, 2010) Table 12.2-1 for additional footnotes.

For SI: 1 ft = 0.305 m

E2.2.3 Type I or Type II Shear Walls

For relevant commentary on *Type I* or *Type II shear walls* with *steel sheet sheathing*, see Section E1.2.3.

E2.2.4 Seismic Load Effects Contributed by Masonry and Concrete Walls

For general commentary on seismic *load effects* contributed by masonry and concrete walls, see Section B1.4.

E2.3 Shear Strength [Resistance]

E2.3.1 Nominal Strength [Resistance]

The commentary for *nominal strength* [resistance] is comparable to that of *shear walls* sheathed with *wood structural panels*. Refer to *Commentary* Section E1.3.1.

Serrette et al. (2006) conducted tests on *cold-formed steel frame shear walls* utilizing structural adhesives. The walls with *steel sheet sheathing* attached by a structural adhesive exhibited a more nonlinear behavior with a less severe reduction in strength after the maximum resistance compared to the OSB sheathing; however, testing of such systems has been too limited to include specific provisions in this *Standard*.

E2.3.1.1 Type I Shear Walls

In the United States and Mexico: In 2007, in a precursor to this *Standard* (AISI S213), adjustments were made to Table E2.3-1 for 0.027 in. steel sheet, one side, based on testing at the University of North Texas (Yu, 2007). *Designation thickness* for *stud*, *track* and *blocking* associated with the existing 0.027 in. steel sheet tabulated values was increased from 33 mils (min.) to 43 mils (min.). New values were added for *designation thickness* for *stud*, *track* and *blocking* equal to 33 mils (min.).

E2.3.1.1.1 Effective Strip Method

In the United States and Mexico: The Effective Strip Method for determining the *nominal shear strength* [resistance] for *Type I shear walls* with steel sheet sheathing is based on research by Yanagi and Yu (2014). The method assumes a sheathing strip carries the lateral load via a tension field action as illustrated in Figure C-E2.3.1.1.1-1. The shear strength of the shear wall is controlled by the tensile strength of the effective sheathing strip, which is determined as the lesser of the fasteners' tensile strength and the yield strength of the effective sheathing strip. The statistical analysis in Yanagi and Yu (2014) yielded an LRFD resistance factor of 0.79 for the Effective Strip Method. In order to keep consistence in resistance factors (0.60 for LRFD) specified in *Standard* Section E2.3.2, the original design equation in Yanagi and Yu (2014) was adjusted accordingly.

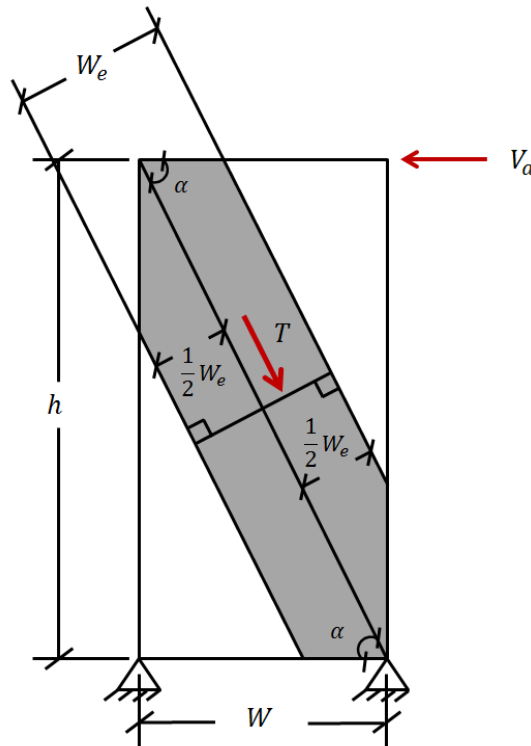

Figure C-E2.3.1.1.1-1 – Effective Strip Model for Steel Sheet Sheathing

E2.3.1.1.2 Wall Pier Limitations

For relevant commentary, see Section E1.3.1.1.1.

E2.3.1.1.3 Both Wall Faces Sheathed With the Same Material and Fastener Spacing

For relevant commentary, see Section E1.3.1.1.2.

E2.3.1.1.4 More Than a Single Sheathing Material or Fastener Configuration

For relevant commentary, see Section E1.3.1.1.3.

E2.3.1.2 Type II Shear Walls

For relevant commentary on *Type II shear walls* with *steel sheet sheathing*, see Section E1.3.1.2. Although the Dolan (1999, 2000a, 2000b) work discussed in Section E1.3.1.2 was based on *wood structural panel* sheathing, the Committee felt it was appropriate to extend this methodology to *shear walls* with *steel sheet sheathing* due to the similar performance of *wood structural panel* sheathing and *steel sheet sheathing* in monotonic and cyclic tests (Serrette, 1997) of *Type I shear walls*.

E2.3.2 Available Strength [Factored Resistance]

The requirements are comparable to those of *cold-formed steel* light frame *shear walls* with wood sheathing. In Canada, the *resistance factors* for steel sheathed shear walls are obtained from the research (Balh, et. al, 2014; DaBreo, et. al., 2014). Refer to *Commentary* Section E1.3.2.

E2.3.3 Expected Strength [Probable Resistance]

The requirements are comparable to those of *cold-formed steel* light-frame *shear walls* with wood sheathing. Refer to *Commentary* Section E1.3.3.

E2.4 System Requirements

E2.4.1 Type I Shear Walls

E2.4.1.1 Limitations for Tabulated Systems

For relevant commentary, see Section E1.4.1.1.

E2.4.1.2 Required Strength [Effect Due to Factored Loads] for Chord Studs, Anchorage, and Collectors

For relevant commentary, see Section E1.4.1.2.

E2.4.1.3 Required Strength [Effect Due to Factored Loads] for Foundations

For relevant commentary, see Section E1.4.1.3.

E2.4.1.4 Design Deflection

The requirements for design deflections of the *shear walls* with steel sheet sheathing are comparable to those of *shear walls* with wood sheathings. Refer to *Commentary* Section E1.4.1.1. The ρ term in *Standard* Equation E2.4.1.4-1 accounts for the effect of different sheathing materials on the observed response of walls with similar framing, fasteners and fastener schedules. Low values of ρ for *steel sheet sheathing* are a result of shear buckling in the sheet. In 2012, in a precursor to this *Standard* (AISI S213), coefficients β and ρ in deflection equation C-E1.4.1.4-1 were revised for *steel sheet sheathing* based on research results compiled by Cobeen (2010).

E2.4.2 Type II Shear Walls

For relevant commentary, see Section E1.4.2.

E3 Cold-Formed Steel Light Frame Strap Braced Wall Systems

Cold-formed steel light frame strap braced wall systems are common in wind design and may be successfully employed in seismic design if designed and detailed with care. Specifically, the design must ensure the diagonal tension *strap(s)* yield and other *limit states* (fracture at the *strap* ends, buckling of the *chord studs*, etc.) are avoided for sufficient story drifts.

To the extent possible, the provisions of this section are written in a parallel format to those of Section E1, Cold-Formed Steel Light Frame Shear Walls Sheathed With Wood Structural Panels. It is recommended that the commentary of Section E1 be referenced in addition to the specifics of this section, particularly for discussions of the overall design basis provided in Section E1.

E3.2 Basis of Design

E3.2.1 Designated Energy-Dissipating Mechanism

For *cold-formed steel light frame strap braced wall* systems, yielding of the tensile *straps* provides the required energy dissipation; and the other elements of seismic load-resisting system, including *connections*, *chord studs*, and *tracks*, etc. should be designed for the force resulted from the expected strength [probable resistance] of the tensile *straps*.

E3.2.2 Seismic Design Parameters [Seismic Force Modification Factors and Limitations] for Seismic Force-Resisting System

In the United States and Mexico: AISI S400 is employed in conjunction with the *applicable building code* documents. For ASCE/SEI 7 (ASCE, 2010), the design coefficients, factors and limitations assigned to light-framed *shear wall* systems in ASCE/SEI 7 are reproduced in Table C-E3.2.2.

In Canada: When R_dR_o is greater than 2 for diagonal *strap braced walls*, AISI S400 is mandatory. For diagonal *strap braced walls*, a designer has the option to choose an R_dR_o of 1.625 for systems with a higher R_dR_o to determine the seismic load and thereby avoid the special detailing in AISI S400. For this case, the height limitations for “Conventional Construction” in Table 1.2-1 in the Appendix 1 of AISI S400 would apply. Note that the lower R_dR_o value of 1.625 associated with diagonal *strap bracing* was chosen to ensure that the system remains essentially elastic. Additional guidance is provided in Section E7.

Table C-E3.2.2^d
United States and Mexico
Design Coefficients and Factors for Strap Braced Wall Systems

Basic Seismic Force-Resisting System ^b	Seismic Response Modification Coefficient, R	System Over-strength Factor, Ω_0^c	Deflection Amplification Factor, C_d	Structural System Limitations and Building Height (ft) Limitations ^a				
				Seismic Design Category				
				A&B	C	D	E	F
A. Bearing Wall Systems								
Light-framed wall systems using flat strap bracing	4	2	3 ½	NL	NL	65	65	65

^a NL = Not Limited and NP = Not Permitted.

^b Per ASCE/SEI 7 (ASCE, 2010), a bearing wall system is defined as a structural system with bearing walls providing support for all or major portions of the vertical loads. Per this standard, braced frames are the basic seismic force resisting elements.

^c The tabulated value of the overstrength factor, Ω_0 , is permitted to be reduced by subtracting one-half for structures with flexible *diaphragms*, but shall not be taken as less than 2.0 for any structure.

^d See ASCE/SEI 7 (ASCE, 2010) Table 12.2-1 for additional footnotes.

For SI: 1 ft = 0.305 m

E3.2.3 Seismic Load Effects Contributed by Masonry and Concrete Walls

For general commentary on seismic *load effects* contributed by masonry and concrete walls, see Section B1.4.

E3.3 Shear Strength [Resistance]

E3.3.1 Nominal Strength [Resistance]

The *nominal shear strength* [resistance] is calculated based on projecting the *nominal strength* [resistance] of the tensile *straps* on the horizontal axis, ignoring the strength of the buckled compressive *straps*, and assuming pinned *connections*. If the *strap* is not across the full height and length of the wall, then the height and length of the area that the *strap* occupies should be used in this section and the horizontal forces must be resolved in detailed *blocking*.

E3.3.2 Available Strength [Factored Resistance]

Given that the *designated energy-dissipating mechanism* defines the response of the full wall, the resistance (ϕ) and safety factors (Ω) provided for the *strap braced wall* system are based on the yielding *limit state* and utilize the ϕ and Ω established in AISI S100 [CSA136].

E3.3.3 Expected Strength [Probable Resistance]

For a *strap braced wall*, the wall expected strength [probable resistance] can be determined in accordance with the following:

$$V_n = R_y A_g F_y w / \sqrt{h^2 + w^2} \quad (\text{Eq. C-E3.3.3-1})$$

where

h = Height of the wall

w = Length of the wall

R_y = Value per *Standard* Section A3.2

A_g = Gross area of the flat *straps* (sum of the area of the tensile *straps* on both sides of the wall)

F_y = Yield stress of the flat *straps*

E3.4 System Requirements

E3.4.1 Limitations on System

Proper detailing is required to ensure that yielding of the *strap* is the realized *limit state*. Special seismic requirements for *strap braced walls* were first introduced in 2007 in a precursor to this *Standard* based largely on the research of Rogers at McGill University (Al-Kharat and Rogers, 2005, 2006, 2007), testing by Jim Wilcoski of the U.S. Army Corps of Engineers, and engineering judgment. The *Standard* provides three methods for ensuring the yielding *limit state* of the *strap* at the critical *strap-to-stud* and track *connection*: (1) weld, (2) avoid fracture in the net cross-section at expected strength levels, or (3) test. Method (1), welding, is generally the simplest solution – the weld should be designed for the expected strength of the *strap*. Method (2) requires that the expected ultimate-to-yield ratio be greater than 1.2 (to ensure material ductility) and that the expected net section fracture strength is greater than the expected yield strength of the *strap*. Velchev and Rogers (2008) demonstrated that screw-connected walls designed following Method (2) can reach similar inelastic drifts to the weld-connected walls. This study also demonstrated that the use of reduced width fuse braces makes the brace end *connection* requirements easier to satisfy; however, the research report outlines some key design aspects to using these braces that need to be considered. The *Standard* Equations E3.4.1-1 and E3.4.1-2 establish that net section fracture does not control the behavior of the *strap*. This further implies that *available strength* [*factored resistance*] in net section fracture need not be checked.

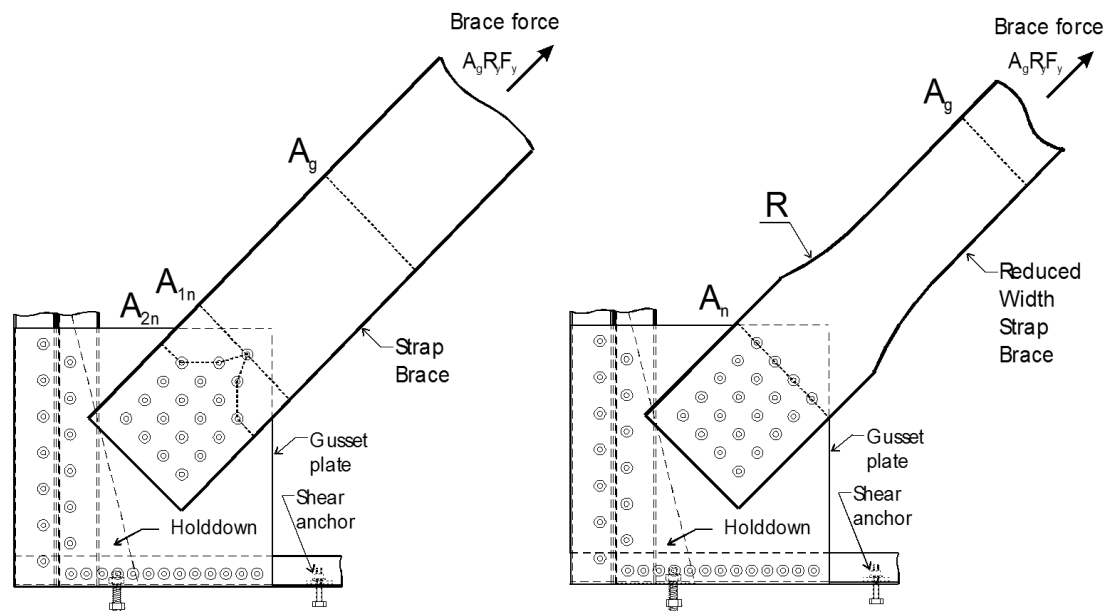

Figure E3.4.1-1 – Regular Brace Versus Reduced Width Fuse Brace (Velchev and Rogers, 2008)

The slenderness of tension-only diagonal *strap bracing* is not limited because *straps* are expected to be installed taut and are typically not used in an exposed condition where vibration of the *strap* may be an issue.

Comeau and Rogers (2008) demonstrated that allowing for supplementary holes in regular braces due to attaching the *straps* with screws to the interior *studs* does not have an adverse impact on the overall ductility. However, strict control was used in the size of the screws (No. 8) and number of screws (1 per brace to interior *stud connection*). The use of multiple screws or screws close to the edge of a brace may reduce the lateral ductility. It is assumed that penetrations in the braces by the use of No. 6 screws for the application of drywall or similar products would not be detrimental given the observed performance of the walls with No. 8 screws installed in the braces. The one exception to this would be the use of screws in the fuse section of a reduced width brace (short fuse section).

The *Standard* does not require that the horizontal shear force from the diagonal brace be resisted by a device connected directly to the diagonal brace and anchored directly to the foundation or supporting structural element when the *track* is designed to resist the horizontal shear force by compression or tension because testing (Al-Kharat and Rogers, 2005, 2006, 2007) has shown satisfactory performance of such assemblies. Velchev and Rogers (2008) investigated various methods of increasing the *track* capacity such that the expected yield strength of the brace can be carried. This study concluded that it was most efficient to use thicker *track*. *Track* that is reinforced requires significant effort in terms of labor, and it is not clear as to the length of *track* that needs to be reinforced, nor the number of *connections*. Extending the *track* (i.e., using the *track* in tension) may also be a viable solution.

When subject to lateral force, narrow strap-braced *shear walls* place bending demands in addition to axial demands on the *boundary elements* of the *shear wall*. Strap-braced *shear walls* that have an aspect ratio (h:w) of 1:1 have insignificant bending demands; however, walls with the aspect ratio (h:w) of 2:1 have been experimentally shown to require

consideration of the bending demand in the *chord studs*. Analysis indicates that the bending demands quickly increase for walls with aspect ratios greater than 1:1, and the *Standard* has chosen to require consideration of these moments for aspect ratios greater than 1.9:1. To protect the *energy-dissipating mechanism* of *strap* yielding in walls with aspect ratios greater than 1.9:1, the *boundary elements* must be designed for the bending moments that develop at the expected strength levels of the *strap* in the *strap-braced wall*. To determine these bending moments, the engineer is required to perform a structural analysis where the *boundary element connections* (stud-to-track) are fully fixed. The assumption of full *joint fixity* provides a conservative approximation of the bending demand and has been shown to accurately predict observed failures in tests on strap-braced shear walls. See Mirzeai et al. (2015) for a complete discussion.

The structural analysis may be completed using frame analysis in software or in closed-form as presented here. Lateral load on a strap-braced *shear wall* is resisted by truss action (subscript T) and frame action (subscript F). The stiffness of each individually in resisting shear is:

$$k_T = \left[\frac{h^3}{b^2 E A_c} + \frac{(h^2 + b^2)^{1.5}}{b^2 E A_s} \right]^{-1} \quad (\text{Eq. C-E3.4.1-1})$$

$$k_F = \left(\frac{\left(\frac{6I_b}{I_c} + \frac{4b}{h} \right) \times \frac{h^3}{24EI_c}}{\left(\frac{6I_b}{I_c} + \frac{b}{h} \right)} \right)^{-1} \quad (\text{Eq. C-E3.4.1-2})$$

where

k_T = Lateral stiffness of truss system

h = Height of wall

b = Width of wall

E = Modulus of elasticity of steel

A_c = Cross-sectional area of *chord stud*

A_s = Cross-sectional area of *strap*

k_F = Lateral stiffness of frame system

I_b = Moment of inertia of *track* about the axis of bending under frame action

I_c = Moment of inertia of *chord stud* about the axis of bending under frame action

For a shear force, V (developed from the expected strength of the *strap*), the deflection, δ , of the wall is:

$$\delta = \frac{V}{k_F + k_T} \quad (\text{Eq. C-E3.4.1-3})$$

The amount of shear attributed to the frame action, V_F , is:

$$V_F = (k_F)\delta \quad (\text{Eq. C-E3.4.1-4})$$

V_F results in a moment at the base of the *chord stud* (M_b) and a moment above the *hold-down* (M_h) due to frame action, which can be calculated by using Equations C-E3.4.1-5 and C-E3.4.1-6:

$$M_b = \frac{V_F h}{2} \left(\frac{\frac{3I_b h}{I_c b} + 1}{\frac{6I_b h}{I_c b} + 1} \right) \quad (\text{Eq. C-E3.4.1-5})$$

$$M_h = M_b \left(\frac{\frac{M_b}{0.5V_F} - h_0}{\frac{M_b}{0.5V_F}} \right) \quad (\text{Eq. C-E3.4.1-6})$$

where h_0 is the distance from the base to the top of the *hold-down*. The assumption, consistent with experimental observations, is that the *hold-down* stiffens the *chord stud* and the critical location for axial and bending demands is at the cross-section of the *chord stud* immediately adjacent to the end of the *hold-down*. As a result, the *Standard* requires that this location (M_h) be checked – this provides some relief from the large bending demands that are assumed from the assumption of full *joint fixity*.

The deflection calculated per Equation C-E3.4.1-3 is not intended to be an approximation of actual system deflection for the purposes of seismic design. The provisions for narrow strap-braced *shear walls* do not allow frame action to be considered in the *nominal strength [nominal resistance]*, but do require that frame action be considered to ensure the desired *energy-dissipating mechanism* of *strap yielding* is achieved.

E3.4.2 Required Strength [Effect of Factored Loads] for Seismic Force-Resisting System

To develop a desirable response, this *Standard* requires that elements of the *lateral force-resisting system* that deliver seismic forces to the diagonal *straps* (other than the *diaphragm*) be capable of developing the expected yield strength of the diagonal *strap bracing* member or, if lower, the expected overstrength (Ω_o times the design seismic load [United States and Mexico] or seismic loads calculated with $R_d R_o = 1.0$ [Canada]) of the diagonal *strap bracing* member.

The *Standard* requires that eccentricity be considered in the design where single-sided diagonal *strap bracing* is provided. Single-sided diagonal *strap bracing* causes an eccentric compression force to be applied to the *chord studs*, which results in a strong axis moment in addition to the axial force. The eccentricity is half of the *stud* depth.

E3.4.3 Required Strength [Effect of Factored Loads] for Foundations

See the commentary to Section E1.4.1.3 for additional discussion.

E3.4.4 Design Deflection

For *strap-braced walls*, it is acceptable to compute the deflection using standard engineering analysis. Deflection calculations should consider all elements that contribute to the horizontal top of wall displacement, including axial deformation of the *studs*, elongation of the *straps*, tilting and *bearing* at *connections* if screws are used, and a lateral contribution from *hold-down* and anchorage deformation, as well as additional deflections that may result for other *components* in a structure (for example, wood sills and raised floors). Loose *straps* permit lateral displacement without resistance. This *Standard* requires that *straps* be installed taut.

E4 Cold-Formed Steel Special Bolted Moment Frames (CFS–SBMF)

Cold-Formed Steel Special Bolted Moment Frame (CFS–SBMF) systems are a unique cold-formed steel seismic force-resisting system. The basic configuration uses HSS uprights and relatively stocky cold-formed steel channel beams with a specially detailed bolt group at the beam-to-column connection. Due to limitations of existing testing, the system is limited to a single story (and additional limitations as detailed herein). This specialized system has existing applications in mezzanine and residential structures.

To the extent possible, this section is provided in a parallel format to the others of Chapter E. However, due to the unique nature of the system as compared with *shear walls* and *strap-braced walls* and reflecting the separate development (AISI S110-07w/S1-09 is the precursor to this section), the provisions have a number of unique features that are addressed in this commentary.

E4.1 Scope

The provisions provided in this section do not apply to Canada. The *nominal, available,* and expected strengths provided here are anticipated to be applicable in Canada; however, since the 2014 NBCC does not provide *seismic performance factors* for this system, the engineer would be required to use elastic design ($R_d R_o = 1$), which removes the advantage of employing the system regardless of its performance.

E4.2 Basis of Design

E4.2.1 Designated Energy- Dissipating Mechanism

Cold-Formed Steel Special Bolted Moment Frame (CFS–SBMF) systems are expected to experience substantial inelastic deformation during significant seismic events. It is expected that most of the inelastic deformation will take place at the bolted connections, due to slip and bearing. To achieve this, beams and columns should have sufficient strength when subjected to the forces resulting from the motion of the design earthquake. Hong and Uang (2004) tested a total of nine full-scale beam-column specimens; see Table C-E4.2-1 for the test matrix. These specimens simulated a portion of an interior beam-to-column subassembly with a column height of 8.25 ft (2.51 m) and a bay width of 11 ft (3.35 m). This testing program demonstrated that this type of system can develop significant ductility. Figure C-E4.2-1 illustrates the typical hysteresis behavior. All specimens developed a story drift capacity significantly larger than the 0.04 radians required for Special Moment Frames (SMF) in the ANSI/AISC 341 (AISC, 2010).

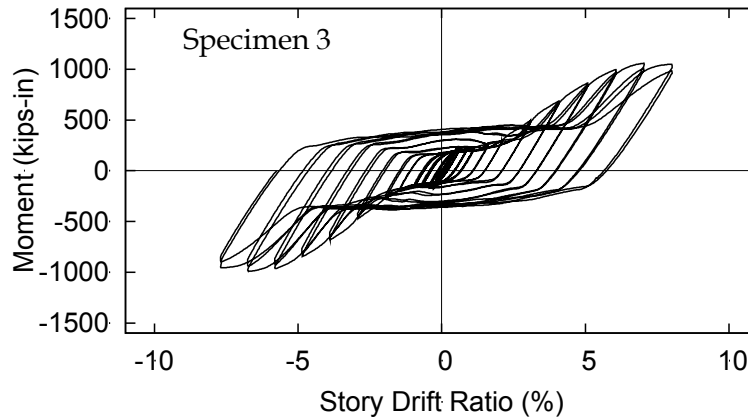

Figure C-E4.2-1 Typical Hysteresis Behavior of CFS-SBMF Systems (Hong and Uang, 2004)

Table C-E4.2-1
Test Matrix

Specimen No.	Beam	Column	Bearing Plate in. (mm)	Bolt configuration [†] , in.		
				a, in. (mm)	b, in. (mm)	c, in. (mm)
1, 2	2C12 × 3 ¹ / ₂ × 0.105	HSS8 × 8 × 1/4	0.135 (3.43)	2 ¹ / ₂ (63.5)	3 (76.2)	4 ¹ / ₄ (108)
3	2C16 × 3 ¹ / ₂ × 0.105	HSS8 × 8 × 1/4	N/A	3 (76.2)	6 (152)	4 ¹ / ₄ (108)
4	2C16 × 3 ¹ / ₂ × 0.105	HSS8 × 8 × 1/4	0.135 (3.43)	3 (76.2)	6 (152)	4 ¹ / ₄ (108)
5, 6, 7	2C16 × 3 ¹ / ₂ × 0.135	HSS8 × 8 × 1/4	N/A	3 (76.2)	6 (152)	4 ¹ / ₄ (108)
8, 9	2C20 × 3 ¹ / ₂ × 0.135	HSS10 × 10 × 1/4	N/A	3 (76.2)	10 (254)	6 ¹ / ₄ (159)

Note: [†] 1 in. (25.4 mm) diameter A325 bearing type high-strength bolts.

See Figure C-E4.2-1 for definitions of dimensions a, b, and c.

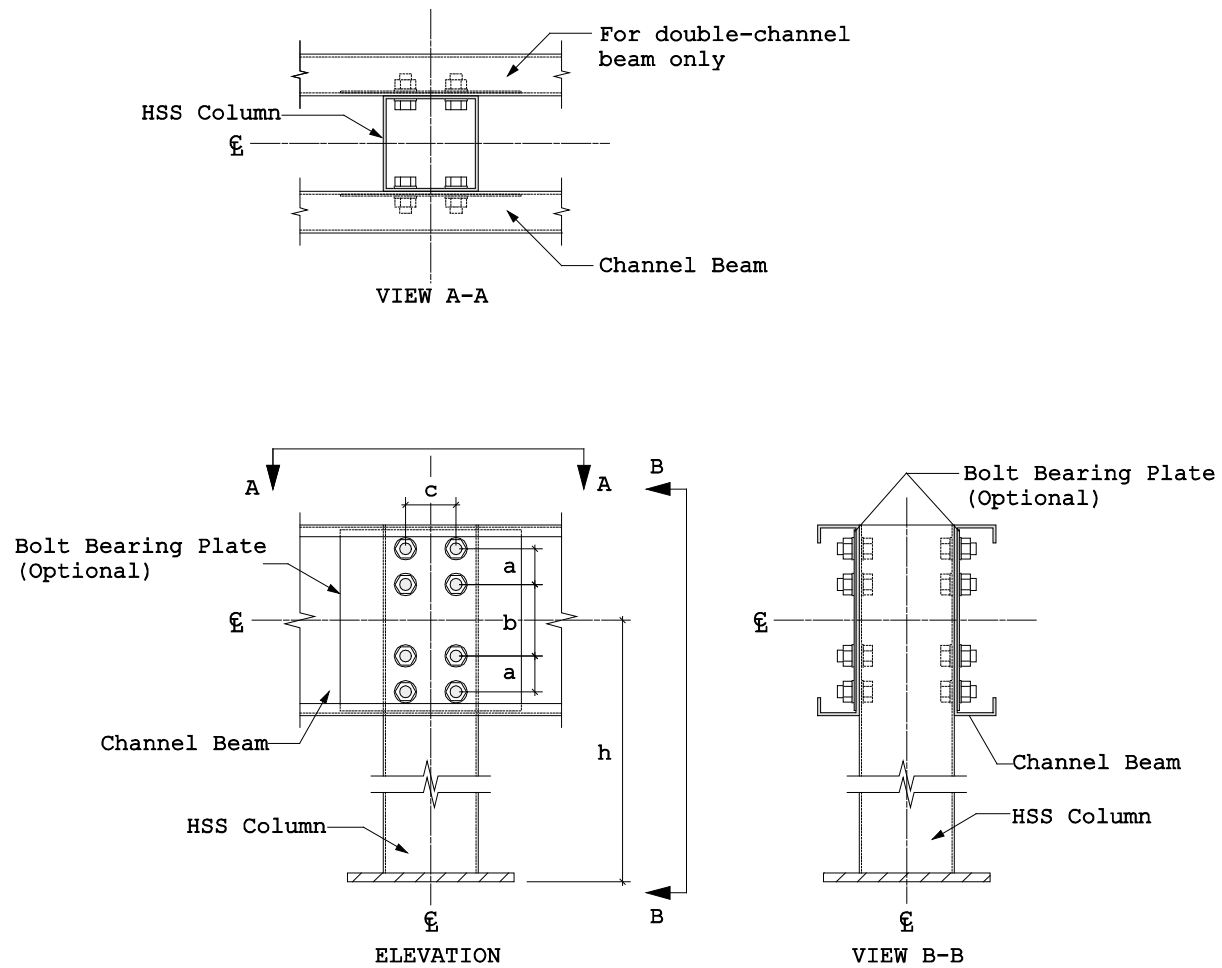

Figure C-E4.2-1 Typical CFS-SBMF System Bolted Connection

E4.2.2 Seismic Design Parameters for Seismic Force-Resisting System

The explanations in *Commentary* Section E1.2.2 are generally applicable to *Cold-Formed Steel Special Bolted Moment Frame (CFS-SBMF)* after superseding Table C-E1.2.2 with Table C-E4.2.2 for the seismic design parameters.

Table C-E4.2.2^b
United States and Mexico
Design Coefficients and Factors for Cold-Formed Steel
Special Bolted Moment Frames (CFS-SBMF)

Basic Seismic Force-Resisting System	Seismic Response Modification Coefficient, R	System Over-strength Factor, Ω_o	Deflection Amplification Factor, C_d	Structural System Limitations and Building Height (ft) Limitations ^a				
				Seismic Design Category				
				A&B	C	D	E	F
C. Moment-resisting frame systems								
Cold-formed steel-special bolted moment frames	3 ½	3	3 ½	35	35	35	35	35

^a NL = Not Limited and NP = Not Permitted.

^b See ASCE/SEI 7 (ASCE, 2010) Table 12.2-1 for additional footnotes.

For SI: 1 ft = 0.305 m

E4.2.3 Seismic Load Effects Contributed by Masonry and Concrete Walls

For general commentary on seismic *load effects* contributed by masonry and concrete walls, see Section B1.4.

E4.3 Strength

E4.3.1 Required Strength

The *required strength* [effect due to *factored loads*] of a *seismic force-resisting system* should be determined in accordance with the *applicable building code*. An amplification or overstrength factor, Ω_o , applied to the horizontal portion of the earthquake load E is prescribed in the *applicable building code*.

In 2009, the system overstrength factor, Ω_o , was decreased to 3.0 and deflection amplification factor, C_d , was increased to 3.5. These changes reflect recommendations from the Building Seismic Safety Council Provisions Update Committee.

E4.3.1.1 Beams and Columns

To provide elastic beams and columns and to mobilize the expected inelastic deformation at the bolted *connection*, beams and columns should have sufficient strength when subjected to the forces resulting from the *design earthquake*. To achieve this, the *required strength* [effect of *factored loads*] of beams and columns should be determined in accordance with the *expected strength* [*probable resistance*] of the *connections*.

E4.3.1.2 Bolt Bearing Plates

Most of the time, the beam *web bearing* strength is not enough to provide slippage in the *connection*. Accordingly, as shown in Figure C-E4.2-1, *bearing* plates can be used to increase the *bearing* strength of the beam *web*. The *bearing* plate thickness can be added to the *web* thickness in *bearing* calculations if the holes have been drilled through both the beam *web* and the *bearing* plate after welding the *bearing* plate.

E4.3.2 Available Strength

The *available strength [resistance]* of systems, members and *connections* should be determined in accordance with AISI S100, except as modified by this *Standard*.

E4.3.3 Expected Strength

To ensure that inelastic action will only occur at the bolted *connections*, *capacity--based design* principles should be followed to calculate the maximum force that can be developed in these *connections* at the *design story drift*. Beams and columns are then designed to remain essentially elastic based on this maximum force.

It is common that all the beams in CFS-SBMF are the same size, and so are all the columns. All the beam and column *connections* have the same bolt configuration. This leads to the assumption of the desirable yield mechanism with the expected distribution of column shears as shown in Figure C-E4.3.3-1(a). The lateral load response of one column is shown in Figure C-E4.3.3-1(b). At the *design story drift*, Δ , the column shear is $(V_S + R_t V_B)$, and the expected moment at the bolt group is

$$M_e = h(V_S + R_t V_B) \quad (\text{Eq. C-E4.3.3-1})$$

where h is story height, and R_t is the factor given in *Standard* Table A3.2-1.

In the above equation, V_S is the column shear that causes the bolt group to slip [Point a in Figure C-E4.3.3-1(b)]; R_t is the ratio of expected tensile strength to *specified minimum tensile strength*. The bolt hole oversize allows the bolt group to rotate, which produces a component of story drift of Δ_S in Figure C-E4.3.3-1(b), until bolt *bearing* occurs (Point b). To overcome the *bearing* resistance, the additional column shear required to reach the *design story drift* (Point c) is defined as $R_t V_B$.

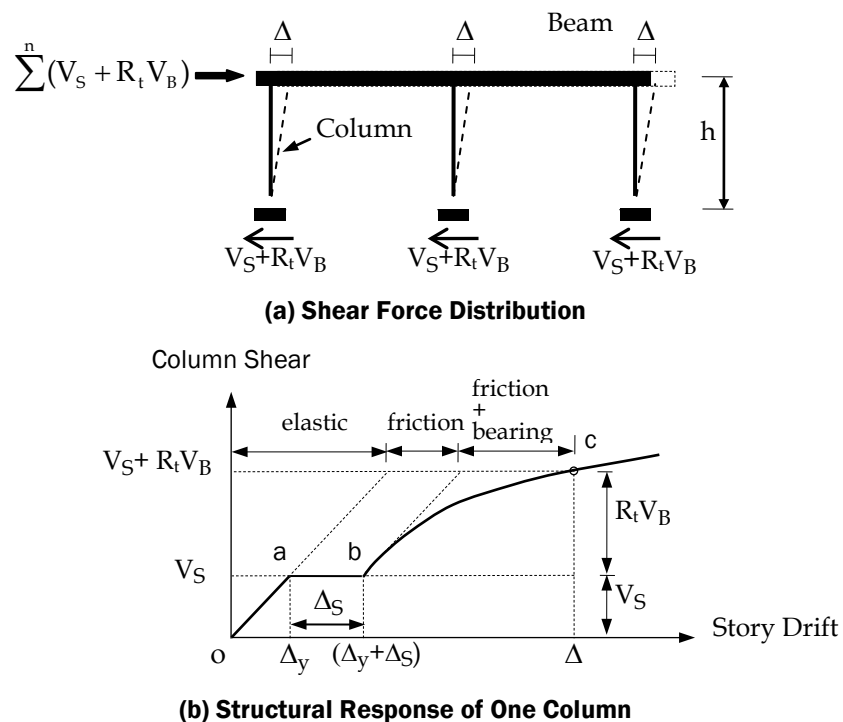

Figure C-E4.3.3-1 General Structural Response of CFS-SBMF System

Figure C-E4.3.3-2 shows a bolt group with an eccentric shear at the column base. The instantaneous center (IC) of rotation concept (Crawford and Kulak, 1971) can be applied to compute the required response quantities. At the bolt level, the slip resistance of one bolt, R_S , is

$$R_S = kT \quad (\text{Eq. C-E4.3.3-2})$$

where k = slip coefficient and T = *snug-tight bolt* tension. A value of $k = 0.33$ is assumed, and the value of T ranges from 10 kips (44.5 kN) to 25 kips (111 kN) for 1-in. (25.4 mm) diameter *snug-tight bolts*. For design purposes, a value of T equal to 10 kips (44.5 kN) is recommended for 1-in. (25.4 mm) diameter *snug-tight bolts*.

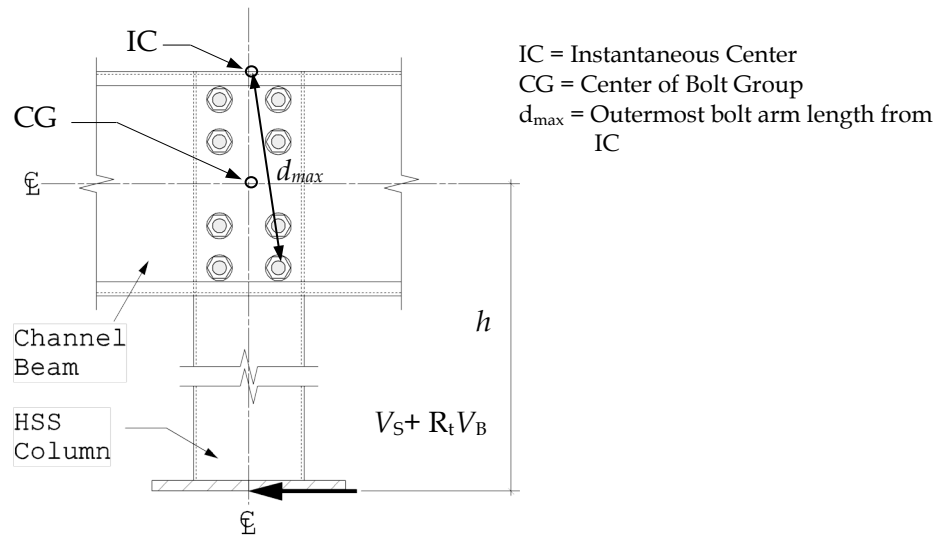

Figure C-E4.3.3-2 Bolt Group in Eccentric Shear

The slip range, Δ_S , in Figure C-E4.3.3-1(b) is a function of the bolt hole oversize and can be computed as

$$\Delta_S = \frac{2h_{os}h}{d_{max}} \quad (\text{Eq. C-E4.3.3-3})$$

where

h_{os} = Hole oversize (difference between hole diameter and bolt diameter)

d_{max} = Outermost bolt arm length from instantaneous center (IC)

The *bearing* resistance of a bolt is

$$R_B = R_{ult}(1 - e^{-\mu\delta})^\lambda \quad (\text{Eq. C-E4.3.3-4})$$

where

δ = *Bearing* deformation

R_{ult} = Ultimate *bearing* strength

e = 2.718

μ and λ = Regression coefficients

For application in *Cold-Formed Steel Special Bolted Moment Frame (CFS-SBMF)*

systems, $\mu = 5$ and $\lambda = 0.55$ gave a reasonable correlation to available test results (Sato and Uang, 2007).

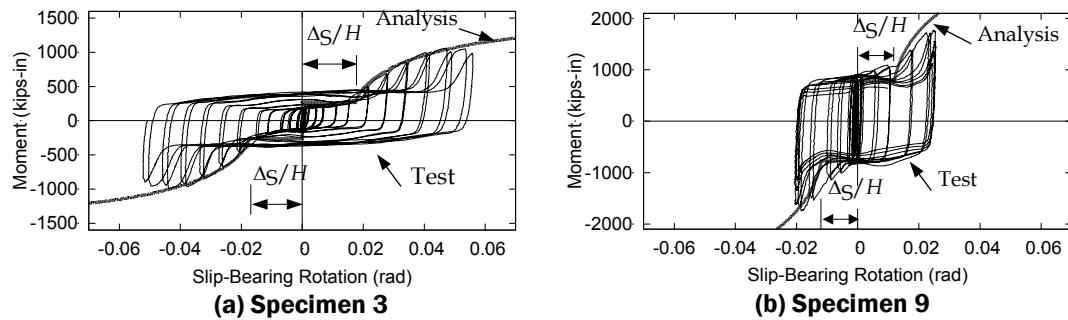

Figure C- E4.3.3-3 Sample Correlation of Bolted Connection Response

Based on the above procedure, sample correlation of two test specimens is shown in Figure C-E4.3.3-3.

Values of V_S and Δ_S can be computed by using the instantaneous center of rotation theory, and Table C-E4.3.3-1 shows the results for some commonly used bolt configurations and story heights. Equations E4.3.3-2 and E4.3.3-7 of the *Standard* are derived from regression analysis of Table C-E4.3.3-1 to facilitate design.

Next, consider V_B in Equation C-E4.3.3-1 (or *Standard* Equation E4.3.3-1). Referring to Point c in Figure C-E4.3.3-1(b), the *design story drift* (Δ) is composed of three components: (1) the recoverable elastic component which is related to the lateral stiffness, K , of the frame, (2) the slip component, Δ_S , from *Standard* Equation E4.3.3-7, and (3) the *bearing* component:

$$\Delta_B = \Delta - \Delta_S - \frac{nM_e}{hK} \quad (\text{Eq. C-E4.3.3-5})$$

where

n = Number of columns in a frame line (i.e., number of bays plus 1)

M_e = Expected moment at a bolt group as defined in *Standard* Section E4.3.3.3

Applying the instantaneous center of rotation concept to the eccentrically loaded bolt group in Figure C-E4.3.3-2 by using the bolt *bearing* relationship in Equation C-E4.3.3-4, the relationship between the *bearing* component of the story drift, Δ_B , and the *bearing* component of the column shear, V_B , can be established. Figure C-E4.3.3-5(a) shows a sample result. For a given story height, the last point of each curve represents the ultimate when the *bearing* deformation of the outermost bolt reaches 0.34 in. (8.6 mm).

Values of $V_{B,max}$ and $\Delta_{B,max}$ for some commonly used bolt configurations and story heights are computed. *Standard* Equations E4.3.3-4 and E4.3.3-6 are derived from regression analysis of Table C-E4.3.3-2 to facilitate design.

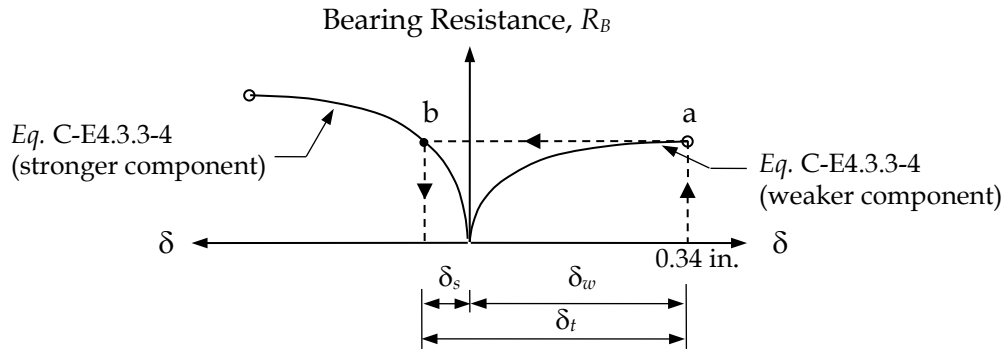

Figure C-E4.3.3-4 Bolt Bearing Deformations in Stronger and Weaker Components

The *Bearing Deformation Adjustment Factor*, C_{DB} , in Equation C-E4.3.3-7 accounts for the additional contribution of *bearing* deformation from the stronger component.

Refer to Point a in Figure C-E4.3.3-4, where the ultimate *bearing* deformation [0.34 in. (8.6 mm)] of the weaker component is reached. Since the *bearing* forces of the bolt between both the weaker and stronger components are identical, it can be shown that the corresponding *bearing* deformation of the stronger component (i.e., Point b) is

$$\delta_s = -\frac{1}{5} \ln \left[1 - 0.817 \left(\frac{(tF_u)_w}{(tF_u)_s} \right)^{1.82} \right] \quad (\text{Eq. C-E4.3.3-6})$$

The C_{DB} factor represents the ratio between the total *bearing* deformation and 0.34 in. (8.6 mm).

$$C_{DB} = \frac{0.34 + \delta_s}{0.34} = 1.0 - 0.588 \ln \left[1 - 0.817 \left(\frac{(tF_u)_w}{(tF_u)_s} \right)^{1.82} \right] \quad (\text{Eq. C-E4.3.3-7})$$

Note that the $\Delta_{B,0}$ values correspond to the maximum drift deformation when the *bearing* deformation is contributed by the weaker component only.

Normalizing each curve in Figure C-E4.3.3-5(a) by its own ultimate *limit state*, Figure C-E4.3.3-5(b) shows that a normalized relationship between V_B and Δ_B can be established:

$$\left(\frac{V_B}{V_{B,\max}} \right)^2 + \left(1 - \frac{\Delta_B}{\Delta_{B,\max}} \right)^{1.43} = 1 \quad (\text{Eq. C-E4.3.3-8})$$

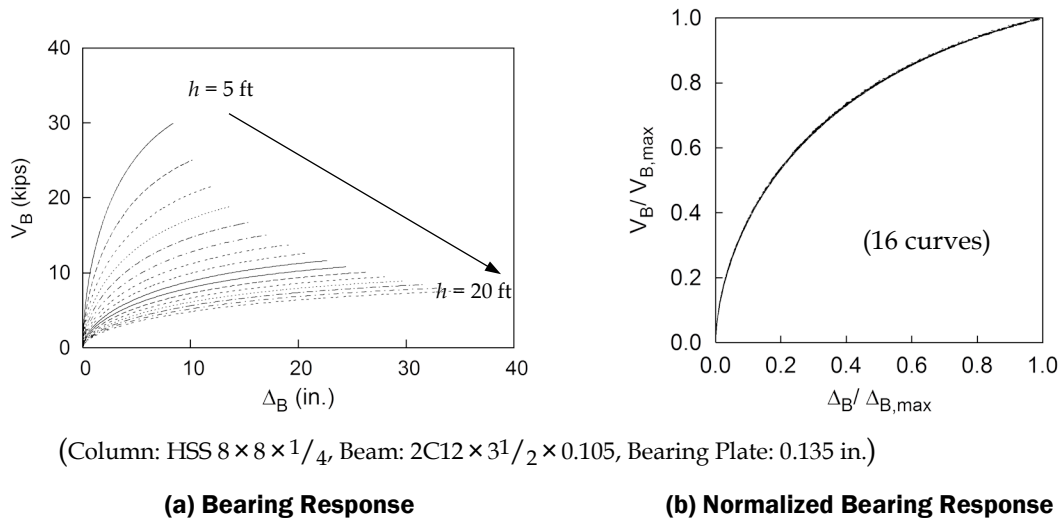

Figure C-E4.3.3-5 Sample Result of Bearing Response

Iteration is required to compute the expected moment, M_e , in Equation C-E4.3.3-1. The following value is suggested as the initial value for Δ_B :

$$\Delta_B = \frac{[\Delta - (\Delta_S + \Delta_y)]K}{nV_{B,max} / \Delta_{B,max} + K} \quad (\text{Eq. C-E4.3.3-9})$$

where Δ_y is the story drift at Point a in Figure C-E4.3.3-1(b).

Table C-E4.3.3-1
Values of G_S and G_{DS} for Eccentrically Loaded Bolt Groups

$V_S = N \times G_S \times R_S$ $\Delta_S = G_{DS} \times h_{os}$ $N = 1$ for single-channel beams $= 2$ for double-channel beams		where V_S = Column shear causing slip R_S = Slip strength per bolt (= $k \times T$) k = Slip coefficient T = Snug-tight bolt tension h = Story height, ft $a, b,$ and c = Bolt spacing, in. Δ_S = Slip drift due to slip G_S, G_{DS} = Coefficient tabulated below H_{os} = Hole oversize					
		Bolt spacing a and b , in.					
c, in.	h, ft	a = 2-1/2, b = 3		a = 3, b = 6		a = 3, b = 10	
		G_S	G_{DS}	G_S	G_{DS}	G_S	G_{DS}
4-1/4	8	0.296	40.5	0.416	26.6	0.562	17.6
	9	0.264	45.8	0.370	30.3	0.501	20.1
	10	0.237	51.0	0.333	34.0	0.452	22.7
	11	0.216	56.3	0.303	37.7	0.411	25.3
	13	0.183	66.9	0.257	45.1	0.349	30.6
	15	0.158	77.5	0.223	52.6	0.303	35.9
	17	0.139	88.1	0.197	60.1	0.268	41.4
	19	0.125	98.7	0.176	67.6	0.240	46.9
	21	0.113	109	0.159	75.1	0.217	52.5
	23	0.103	120	0.145	82.6	0.198	58.1
	25	0.0946	130	0.134	90.2	0.182	63.7
	27	0.0879	141	0.124	97.7	0.169	69.3
	29	0.0818	152	0.115	105	0.157	75.0
	31	0.0763	162	0.108	113	0.147	80.7
33	0.0714	173	0.101	120	0.138	86.4	
35	0.0678	183	0.0955	128	0.130	92.1	
6-1/4	8	0.355	36.2	0.460	25.8	0.597	18.2
	9	0.315	40.9	0.410	29.3	0.531	20.9
	10	0.284	45.6	0.369	32.9	0.479	23.5
	11	0.259	50.4	0.335	36.4	0.436	26.2
	13	0.218	59.8	0.284	43.5	0.370	31.6
	15	0.189	69.3	0.246	50.5	0.321	37.0
	17	0.167	78.7	0.217	57.6	0.283	42.5
	19	0.150	88.2	0.194	64.7	0.253	48.0
	21	0.135	97.6	0.176	71.8	0.229	53.5
	23	0.124	107	0.161	78.9	0.210	59.0
	25	0.114	117	0.148	85.9	0.193	64.6
	27	0.105	126	0.137	93.0	0.179	70.1
	29	0.0977	135	0.127	100	0.166	75.7
	31	0.0915	145	0.119	107	0.156	81.2
33	0.0859	154	0.112	114	0.146	86.8	
35	0.0810	164	0.105	121	0.138	92.4	

Table C-E4.3.3-2
Values G_B and $\Delta_{B,0}$ for Eccentrically Loaded Bolt Groups

$V_{B,max} = N \times G_B \times R_0$ $\Delta_{B,max} = C_{DB} \times \Delta_{B,0}$ <p>$N = 1$ for single-channel beams $= 2$ for double-channel beams</p>		where $V_{B,max}$ = Column shear causing bolt maximum bearing R_0 = Governing values of dtF_u of connected components F_u = Tensile strength t = Bearing thickness d = Bolt diameter G_B = Coefficient tabulated below $\Delta_{B,0}$ = Maximum bearing drift deformation C_{DB} = Bearing deformation adjustment					
		Bolt spacing a and b , in.					
c, in.	h, ft	a = 2-1/2, b = 3		a = 3, b = 6		a = 3, b = 10	
		G_B	$\Delta_{B,0}$, in.	G_B	$\Delta_{B,0}$, in.	G_B	$\Delta_{B,0}$, in.
4-1/4	8	0.524	6.92	0.728	4.77	0.983	3.50
	9	0.466	7.81	0.649	5.40	0.878	4.00
	10	0.420	8.71	0.586	6.04	0.794	4.49
	11	0.381	9.61	0.533	6.68	0.724	4.98
	13	0.323	11.4	0.453	7.95	0.616	5.97
	15	0.281	13.2	0.393	9.23	0.536	6.96
	17	0.247	15.0	0.347	10.5	0.474	7.95
	19	0.222	16.8	0.311	11.8	0.425	8.94
	21	0.200	18.6	0.281	13.1	0.385	9.92
	23	0.183	20.4	0.257	14.3	0.352	10.9
	25	0.169	22.2	0.237	15.6	0.325	11.9
	27	0.156	24.0	0.220	16.9	0.301	12.9
	29	0.145	25.8	0.204	18.2	0.281	13.9
	31	0.136	27.6	0.191	19.5	0.262	14.9
33	0.127	29.4	0.180	20.7	0.247	15.8	
35	0.120	31.2	0.169	22.0	0.233	16.8	
6-1/4	8	0.637	6.17	0.814	4.48	1.05	3.36
	9	0.566	6.97	0.725	5.08	0.935	3.82
	10	0.510	7.77	0.654	5.68	0.845	4.29
	11	0.464	8.57	0.595	6.28	0.771	4.76
	13	0.393	10.2	0.504	7.48	0.655	5.70
	15	0.341	11.8	0.438	8.68	0.570	6.65
	17	0.302	13.4	0.387	9.88	0.504	7.59
	19	0.269	15.0	0.347	11.1	0.452	8.54
	21	0.244	16.6	0.314	12.3	0.410	9.48
	23	0.222	18.2	0.287	13.5	0.374	10.4
	25	0.205	19.8	0.264	14.7	0.345	11.4
	27	0.189	21.4	0.244	15.9	0.319	12.3
	29	0.176	23.0	0.228	17.1	0.298	13.3
	31	0.165	24.6	0.213	18.3	0.279	14.2
33	0.154	26.2	0.201	19.5	0.262	15.2	
35	0.146	27.8	0.189	20.7	0.247	16.1	

$$R_{\mu} = \frac{V_{DBE}}{nV_S} \quad (Eq. C-E4.4.1-1)$$

where V_{DBE} is the elastic base shear corresponding to the design basis earthquake, and R_{μ} is the system ductility reduction factor.

The ratio between the story drifts at Point c and Point a is defined as the system ductility factor:

$$\mu = \frac{\Delta}{\Delta_y} \quad (Eq. C-E4.4.1-2)$$

Newmark and Hall (1982) proposed a relationship between μ and R_{μ} for a single-degree-of-freedom system that responds in an elasto-perfectly plastic (EPP) manner (path o-a-b-c')

$$R_{\mu(N-H)} = \begin{cases} \mu & \text{for } T \geq T_S \\ \sqrt{2\mu - 1} & \text{for } T \leq T_C \end{cases} \quad (Eq. C-E4.4.1-3)$$

where T_S is defined in the *applicable building code*, and $T_C = T_S \sqrt{2\mu - 1} / \mu$. Since the actual response of a CFS-SBMF system exhibits a significant hardening (path o-a-b-c) when the bolts are in bearing, for a given ductility factor it is expected that the ductility reduction factor should be higher than that given in Equation C-E4.4.1-3. A parametric study was conducted, and the result in Table C-E4.4.1-1 shows that it is reasonable to assume the following (Sato and Uang, 2007):

$$R_{\mu} = 1.2R_{\mu(N-H)} \quad (Eq. C-E4.4.1-4)$$

For the period not shorter than T_S (i.e., $T \geq T_S$), the above equation gives $R_{\mu} = 1.2\mu$. Using the relationships in Figure C-E4.4.1-1,

$$\begin{aligned} \Delta &= \mu \Delta_y = \frac{R_{\mu}}{1.2} \Delta_y = \frac{V_{DBE}}{1.2(nV_S)} \left(\frac{nV_S}{K} \right) \\ &= \frac{V_{DBE}}{1.2K} = 0.83\Delta_{DBE} = (0.83R)\Delta_d \end{aligned} \quad (Eq. C-E4.4.1-5)$$

that is, the deflection amplification factor, C_d , is $0.83R$. For an R value of 3.5, the value of C_d is about 3.0. Based upon recommendations from the Provisions Update Committee (PUC) of the Building Seismic Safety Council (BSSC), however, the value of C_d has been conservatively increased to 3.5.

For $T \leq T_C$, a simple expression for C_d cannot be derived. Following a similar procedure would give the following for the design story drift (Sato and Uang, 2007):

$$\Delta = \frac{1}{2K} \left(nV_S + 0.7 \frac{V_{DBE}^2}{nV_S} \right) \quad (Eq. C-E4.4.1-6)$$

where

$$T_C = T_S \left(\frac{nV_S}{V_{DBE}} \sqrt{\frac{2V_{DBE}}{nV_S} - 1} \right) \quad (Eq. C-E4.4.1-7)$$

For structures having a period between T_S and T_C , Δ can be determined from linear interpolation.

Table C-E4.4.1-1
Average Value of R_{μ} Ratio

Ductility Factor	$\mu = 4$	$\mu = 6$	$\mu = 8$
$R_{\mu(\text{actual})}/R_{\mu(\text{EPP})}$	1.14	1.23	1.26

In 2009, the drift limit in AISI S110 (precursor of AISI S400) was deleted in favor of the current allowable story drift in ASCE/SEI 7, which limits the drift to a range from 0.025h for Occupancy Category I and II buildings and structures to as little as 0.015h for Occupancy Category IV buildings and structures. The intent of these drift limits is to control damage to nonstructural components that are attached to the *lateral force resisting system*. However, Footnote c of Table 12.12-1 in ASCE/SEI 7 (ASCE, 2010) waives the drift limit for single-story structures with interior walls, partitions, ceilings, and exterior wall systems that have been designed to accommodate the story drifts. This footnote is certainly valid in the case of most CFS-SBMF systems, which are commonly used in industrial platforms. However, for nonstructural components that are susceptible to drift damage, the more stringent drift limits specified in Table 12.12-1 in ASCE/SEI 7 (ASCE, 2010) should be applied.

For CFS-SBMF, P- Δ effects should conform to the requirements of the *applicable building code*.

E4.4.2 Beams

Unlike the strong column-weak beam concept adopted in ANSI/AISC 341 for Special *Moment Frame* design, buckling of a *cold-formed steel* beam is the most undesirable failure mode in CFS-SBMF systems. As shown in Figure C-E4.4.2-1, rapid strength degradation would occur when the beam *web* flat depth-to-thickness ratio (w/t) is 147. Two measures are taken to avoid such strength degradation: (1) limit the *design story drift* ratio to no greater than 0.05, and (2) limit the w/t ratio to no greater than $6.18\sqrt{E/F_y}$.

In 2009, ASTM A653 was specified for *cold-formed steel* C-section members based on the test database. In addition, limitations on the beam depth, thickness, and surface treatment were added to reflect the test database.

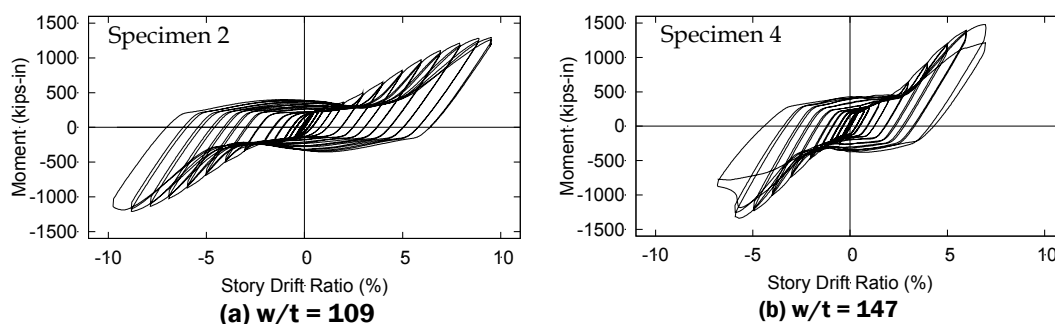

Figure C-E4.4.2-1 Beam Local Buckling Effect on Strength Degradation (Hong and Uang, 2004)

A single-channel beam configuration is permitted by this *Standard*; however, only the double-channel beam configuration has been tested to date. Since the single-channel configuration is unsymmetrical, it could possibly induce torsion into the channel and

column. In 2009, further clarification was added, requiring designers to demonstrate that the torsional effect is properly taken into account when the design uses a single-channel beam.

Typically, the beam top *flanges* are connected to a floor deck (normally steel deck and plywood). This will resist the small torsion in the column due to the load on one side only. Also, designers should include in their column check the ability to add the torsion stress to the bending and axial load stresses to ensure a properly designed column.

If a system is constructed without deck attached to the beam *flanges*, the torsion forces should be included in the column design.

Consider a seismic force at the top of the column which is typically 2 to 3 kips (8.90 to 13.3 kN). The seismic force would result in a torsional moment of $(4 \times 3 = 12 \text{ in-kips (1.36 m-kN)})$ or $5 \times 3 = 15 \text{ in-kips (1.69 m-kN)}$. The seismic moment in the column is in the range of 360 to 600 in-kips (40.7 to 67.8 m-kN) with axial *loads* of 30 to 50 kips (133 to 222 kN). In this case, the torsional moment would not control the design.

E4.4.3 Columns

Column buckling is not as detrimental as beam buckling in terms of strength degradation, partly because the HSS column section is comprised of stiffened elements. When a slender section in accordance with ANSI/AISC 360 (AISC, 2010) is used, test results show that significant strength degradation may occur (see Figure C-E.4.4.3-1). This undesirable failure mode can be avoided by limiting both the flat width-to-thickness ratio to $1.40\sqrt{E/F_y}$ and the maximum story drift to 3 percent of the story height.

In 2009, to reflect limitations of the test database, ASTM A500 for hollow structural section (HSS) members painted with a standard industrial finished surface was specified for columns. Upper and lower limits on the column depths were added as well to mirror the limitations of the tests. In 2015, ASTM A1085 was added as a suitable material for HSS columns.

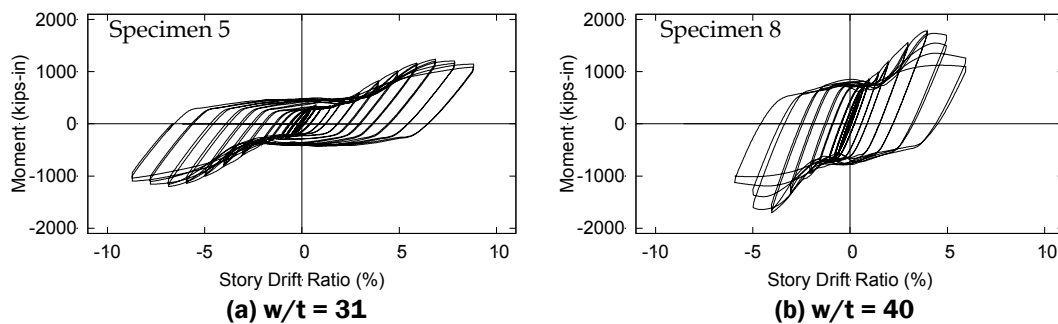

Figure C-E.4.4.3-1 Column Local Buckling Effect on Strength Degradation (Hong and Uang, 2004)

E4.4.4 Connections, Joints and Fasteners

Connections, joints and fasteners that are part of the *seismic force-resisting system* should be designed in accordance with AISI S100, except as modified in this *Standard*.

Tension or shear fracture, bolt shear, and block shear rupture are examples of *limit states* that generally result in non-ductile failure of *connections*. As such, these *limit states* are

undesirable as the controlling *limit state* for *connections* that are part of the *seismic force-resisting system*. Accordingly, it is required that *connections* be configured such that a ductile *limit state* in the member or *connection*, such as yielding or *bearing* deformation, controls the *available strength* [*factored resistance*].

E4.4.4.1 Bolted Joints

This *Standard* prohibits the bolted *joints* being designed to share the load in combination with welds. Due to the potential of full load reversal and the likelihood of inelastic deformations in connecting elements, bolts may exceed their slip resistances under significant seismic *loads*. Welds that are in a common shear plane to these bolts will likely not deform sufficiently to allow the bolts to slip into *bearing*, particularly if subject to load reversal. Consequently, the welds will tend to resist the entire force and may fail if they were not designed as such.

The potential for full reversal of *design load* and the likelihood of inelastic deformations of members and/or connected parts necessitate that bolts in joints of the *seismic force-resisting system* be tightened to at least the snug-tight condition.

Earthquake motions are such that slip cannot and need not be prevented. To prevent excessive deformations of bolted *joints* due to slip between the connected plies under earthquake motions, the use of holes in bolted *joints* in the *seismic force-resisting system* is limited to standard holes and short-slotted holes with the direction of the slot perpendicular to the line of force.

E4.4.4.1.1 Beam- to-Column Connections

Cold-Formed Steel Special Bolted Moment Frame (CFS-SBMF) systems are comprised of *cold-formed steel*, single- or double-channel beams, and hollow structural section (HSS) columns. The beams and columns are connected by snug-tight high-strength bolts. Typical detail for this type of *connection* is shown in Figure C-E4.2-1.

Components of story drift due to the deformation of beam and column, and bolt slippage and *bearing* for a typical test specimen, are shown in Figure C-E4.4.1.1-1 (Hong and Uang, 2004). The inelastic deformation was mainly from the slip and *bearing* deformations of the bolted *connection*. By properly limiting the width-thickness ratios for both the beam and column, inelastic action in these members can be prevented.

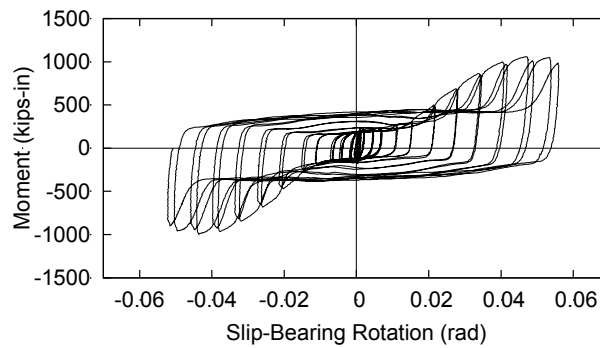

(a) Slip-Bearing Deformation Component

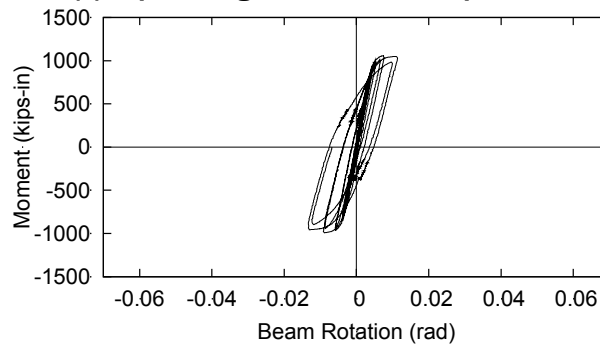

(b) Beam Deformation Component

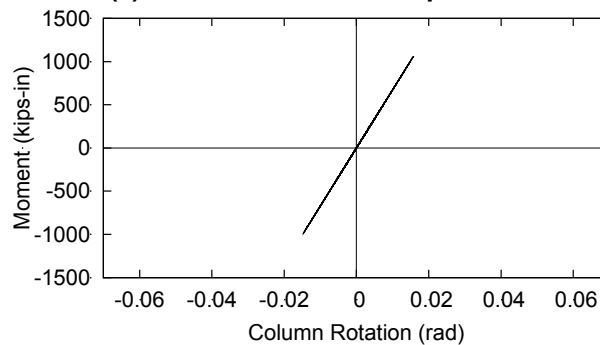

(c) Column Deformation Component

Figure C-E4.4.4.1.1-1 Components of Story Drift (Hong and Uang, 2004)

E4.4.4.1.2 Bolt Bearing Plates

For relevant commentary on bolt *bearing* plates, see Section E4.3.1.2.

E4.4.4.2 Welded Joints

The general requirements for welded *joints* are given in AWS D1.1 (AWS, 2006) and AWS D1.3 (AWS, 1998), as applicable, wherein a Welding Procedure Specification (WPS) is required for all welds. When the typically thin elements of cold-formed structures in tension are joined by welding, it is almost always in single pass flare bevel welds. Many operations during fabrication, erection, and the subsequent work of other trades have the potential to create discontinuities in the *seismic force-resisting system*. When located in regions of potential inelasticity, such discontinuities should be repaired by the

responsible subcontractor. Discontinuities should also be repaired in other regions of the *seismic force-resisting system* when the presence of the discontinuity would be detrimental to the system performance. Repair may be unnecessary for some discontinuities.

E4.4.4.3 Other Joints and Connections

Alternative *joints* and *connections* are permitted by this *Standard* if they are justified by the *professional engineer*.

Alternative *joints* must, as a minimum, provide the same performance as the *joints* permitted by this *Standard*.

E5 Cold-Formed Steel Light Frame Shear Walls With Wood Structural Panel Sheathing on One Side and Gypsum Board Panel Sheathing on the Other Side

Shear walls with wood structural panels on one side and gypsum board panels on the other side are commonly employed in cold-formed steel framing. Limited testing has indicated that the presence of the gypsum board does alter the performance of the wall. In Canada: This may be accounted for by adding the additional capacity from the gypsum panel to the *wood structural panel. In the United States and Mexico:* No such provisions are specifically provided; instead, the presence of the gypsum board is implicit in the system overstrength and other seismic response factors.

This section is organized in a parallel format to that of Section E1. The commentary of Section E1 supplements the material presented here and should be reviewed for additional explanations.

E5.1 Scope

These provisions only apply in Canada. Appropriate *seismic performance factors* have not been determined in ASCE/SEI 7 for use in the United States and Mexico.

E5.2 Basis of Design

As provided in Section E1, *shear walls with wood structural panels* may be designed and detailed in such a way as to ensure a ductile failure mechanism at the sheathing-to-stud connection. Tilting and bearing of the connectors into the *wood structural panel* dissipates energy and is protected in the design of the system. When a gypsum board panel is added to the opposite side, the overall stiffness of the system increases and the gypsum board panel receives the same deformation history as the *wood structural panel*. Although gypsum board panels have a more brittle failure mechanism, they are deformation-controlled by the racking of the wall connected to the *wood structural panel* and thus, beneficial performance is possible. In this situation, both the connections from the *wood structural panel* and the gypsum board panel must be capacity-protected and are the *designated energy-dissipating mechanism*.

E5.3 Shear Resistance

Nominal resistance values for gypsum-sheathed walls were set at 80% of the values found in Table E6.3-1. This reduction in resistance level in Canada vs. the United States is similar to what is found for the wood sheathed walls of similar construction in Table E1.3-1.

E5.4 System Requirements

The system requirements are essentially the same as those of E1 (requirements a to r) with additional limitations related to the application of the gypsum board panel (s to u). For additional relevant commentary, see Section E1.4.

E6 Cold-Formed Steel Light Frame Shear Walls With Gypsum Board or Fiberboard Panel Sheathing

Shear walls with gypsum board or fiberboard panel sheathing have limited ductility, but due to the significant proportion of walls that may be sheathed with these materials, successful seismic performance is possible in some situations. Deformations at the stud-to-sheathing *connections* provide limited energy dissipation. ***In the United States and Mexico:*** This system is recognized, but with a relatively low R and limitations on its applicability in more stringent seismic design categories. ***In Canada:*** This system is not recognized as a separate *seismic force-resisting system*.

This section is organized in a parallel format to that of Section E1. The commentary of Section E1 supplements the material presented here and should be reviewed for additional explanations.

E6.1 Scope

These provisions only apply in the United States and Mexico. Appropriate *seismic performance factors* have not been determined in the NBCC.

E6.2 Basis of Design

The design basis for *shear walls* with gypsum board or fiberboard panels is similar to that of *wood structural panels* as fully discussed in Section E1. Although gypsum board and fiberboard panels have a more brittle failure mechanism than *wood structural panels*, satisfactory performance is possible. Tilting and *bearing* of the fasteners into the gypsum board or fiberboard provides limited energy dissipation and is the *designated energy-dissipating mechanism* for this type of wall.

The limited ductility is reflected in the seismic response factors employed, as summarized from ASCE/SEI 7-10 in Table C-E6.2.2.

Table C-E6.2.2^b
United States and Mexico
Design Coefficients and Factors for Cold-Formed Steel Light Frame Shear Walls With Gypsum Board or Fiberboard Panel Sheathing

Basic Seismic Force-Resisting System ^b	Seismic Response Modification Coefficient, R	System Over-strength Factor, Ω_0 ^c	Deflection Amplification Factor, C_d	Structural System Limitations and Building Height (ft) Limitations ^a				
				Seismic Design Category				
				A&B	C	D	E	F
A. BEARING WALL SYSTEM								
Light-frame walls with shear panels of all other materials	2	2 ½	2	NL	NL	35	NP	NP
A. BUILDING FRAME SYSTEM								
Light-frame walls with shear panels of all other materials	2 ½	2 ½	2 ½	NL	NL	35	NP	NP

^a NL = Not Limited and NP = Not Permitted.

^b Per ASCE/SEI 7 (ASCE, 2010), a bearing wall system is defined as a structural system with bearing walls providing support for all or major portions of the vertical loads. Per this *Standard*, braced frames are the basic seismic force-resisting elements.

^c The tabulated value of the overstrength factor, Ω_0 , is permitted to be reduced by subtracting one-half for structures with flexible *diaphragms*, but shall not be taken as less than 2.0 for any structure.

^d See ASCE/SEI 7 (ASCE, 2010) Table 12.2-1 for additional footnotes.

For SI: 1 ft = 0.305 m

E6.3 Shear Strength

The requirements for *nominal strength* of shear walls with gypsum board or fiberboard panel sheathing are comparable to those of shear walls with wood structural panel sheathing. Refer to Section E1.3.1, and also the following sections for additional commentary.

Strength of *Type I* shear walls with fiberboard panel sheathing are based on studies by the NAHB Research Center (NAHB, 2005) and by the American Fiberboard Association (PFS, 1996; and NAHB, 2006). The *nominal strength* values for shear walls faced with fiberboard in Table E6.3-1 were based on monotonic tests of fiberboard sheathed, cold-formed steel framed shear walls and were compared to the monotonic and cyclic tests that are the basis of the building code tabulated capacities for fiberboard sheathed, wood framed shear walls. For the 2-inch (50.8 mm) and 3-inch (76.2 mm) edge screw spacing, the *nominal strength* values in Table E6.3-1 were based on the average peak load from tests of two 8-foot (2.438-m)-wide by 8-foot (2.428-m)-tall wall specimens. These *nominal strength* values were found to be within 90 percent of the *nominal strength* values for similarly sheathed wood framed walls. The ratio of steel-to-wood *nominal strength* values increased as the edge (perimeter) fastener spacing increased and, therefore, extrapolating the 2/6 (92% ratio) and 3/6 (96% ratio) design values to 4/6 using a ratio of 90% was conservative. For the 4-inch (101.6 mm) edge screw spacing, the *nominal strength* values were calculated as 90 percent of the *nominal strength* value for a

similarly sheathed wood framed wall.

In the United States and Mexico: The upperbound estimate for expected strength introduced in *Commentary* Section B3.3 is also used for gypsum board and fiberboard shear walls. For these shear walls, per ASCE/SEI 7-10 with bearing wall systems, $\Omega_o = 2.5$, and $\phi = 0.6$, results in an upperbound $\Omega_E = 1.5$.

E6.4 System Requirements

The system requirements are similar to those of Section E1 and additional relevant commentary is provided in Section E1.4. The provided requirements are more stringent than typically employed in conventional construction without seismic considerations (for example, in regions that are typically controlled by wind designs for the *lateral force-resisting system*). Engineers are cautioned that all requirements must be met for these systems to provide even the limited ductility that the applicable building code assigns to this system.

Currently, the *shear wall* deflection equations do not include provisions for gypsum board or *fiberboard shear walls*. However, the engineer is reminded that given the low *seismic response modification coefficient*, R , assigned by the building codes to gypsum board *shear walls*, it is expected that these systems will perform near to the elastic range of behavior.

E7 Conventional Construction Cold-Formed Steel Light Frame Strap Braced Wall Systems

In Canada: Seismic performance factors have been assigned for strap braced walls that are conventionally designed and detailed. That is, standard *Limit States Design* per CSA 136 is followed for all *components* and *connections* in the wall, but no special provisions are made to ensure ductility of the *strap*. The convenience of this approach is that a system that is conventionally designed for wind may be checked for seismic using the relatively low R_dR_o that is provided by NBCC. In low seismic zones, the system may be adequate without modification.

In the United States and Mexico: Seismic performance factors similar to the NBCC do not exist for this specific system in ASCE/SEI 7. Instead, the general provisions for “Steel Systems not Specifically Detailed for Seismic Resistance” apply and $R=3$, but only *Seismic Design Categories* A, B, and C are permitted. *Strap braced walls* that have seismic detailing follow the provisions of Section E3 are permitted in higher seismic design categories.

E7.1 Scope

These provisions only apply in Canada. Appropriate *seismic performance factors* have not been determined in ASCE/SEI 7.

E7.2 Basis of Design

Conventional construction using the *Limit States Design* and following CSA 136 ensures that all possible *limit states* have an acceptable failure probability under monotonic loads. *Connection limit states* (e.g., fracture in the net section of the *strap*) use a higher reliability index than member *limit states* (e.g., *strap* yielding, *chord stud* buckling, etc.) and thus *connections* are expected to have a lower probability of failure than member *limit states*. The resulting conventional system has inherent ductility even without a *designated energy-dissipating mechanism*. These provisions recognize this inherent ductility and account for its use in design.

E7.3 Shear Resistance

The lateral shear resistance of the wall is determined by conventional design and is controlled by the governing *limit state* for all *components* and *connections* in the system. The strength expression in Section E3 is only applicable if yielding of the *strap* is the governing *limit state*—a condition that may be logical for preliminary design, and is certainly preferable from a ductile performance standpoint.

E7.4 System Requirements

Beyond conventional construction, this *Standard* requires that the *straps* be pre-tensioned and that the load transfer from the *strap* to the anchorages meet certain limitations in Section E3.4. This is required so that basic cyclic performance can be maintained in the system.

F. DIAPHRAGMS

F1 General

Diaphragms are the roof, floor or other membrane or *bracing* system that transfers in-plane forces to the vertical *seismic force-resisting system*; i.e., the walls. Since most seismic mass is located on the floors and roofs, the *diaphragm* has a special role in the transfer of inertial demands into the walls of a building (or vertical *components* of other structures). As a result, *applicable building codes* provide provisions related to the performance and design of floor *diaphragms*. Successful application of these provisions generally requires knowledge of the strength and stiffness of the *diaphragm*, quantities that this *Standard* provides guidance on.

F1.1 Scope

This *Standard* permits the use of *steel sheet sheathing*, concrete or *wood structural panels* or other *approved* materials to serve as the *diaphragm* sheathing. However, prescriptive provisions are only provided for *cold-formed steel* framing with *wood structural panels*.

This *Standard* does not currently address the design of *diaphragms* in Canada; however, pending the completion of research that is currently underway, it is expected that the design of *diaphragms* in Canada will be addressed in a future edition of the *Standard*.

F1.2 Design Basis

Current design of *diaphragms* (e.g., ASCE/SEI 7-10) does not associate energy dissipation with the *diaphragm* nor tie specific *diaphragm* systems to specific *seismic force-resisting systems*. Although evidence is growing that the *diaphragm* can have a significant impact on the overstrength and ductility of the complete *lateral force-resisting system*, currently this is not part of the design basis for *diaphragms*.

Diaphragms should have an *available strength* that is greater than or equal to the *required strength* from the *applicable building code*. In addition, *diaphragm* stiffness is often needed to determine if the *diaphragm* is rigid, flexible, or semi-rigid. This stiffness distinction is important for understanding how torsional forces develop in the building (or other structure) and how the torsion forces are (or are not) distributed to the vertical *seismic force-resisting systems*.

Diaphragms that dissipate energy are an area of new research, and it is anticipated that future versions of this *Standard* will provide guidance on *capacity-based design* and the role of energy dissipation and overstrength in *diaphragms*.

F1.3 Required Strength

The *required strength* of the *seismic force-resisting systems* of Chapter E are influenced by the *diaphragm* stiffness—i.e., flexible *diaphragms* do not have to consider direction torsion, while rigid *diaphragms* must include in-plane torsion effects resulting from differences in the center of mass and center of stiffness as detailed in the *applicable building code*. It is also possible that a condition between the rigid and flexible extremes (semi-rigid) must be considered for the *diaphragm*. Given uncertainty and complication with determining *diaphragm* stiffness, the User Note provides guidance on a conservative approach in common use in current practice: check both rigid and flexible *diaphragm* conditions and take the worst-case loads for the *required strength* on the *seismic force-resisting systems*.

For *cold-formed steel* framed *diaphragms* with *wood structural panels*, this *Standard* provides explicit provisions for stiffness. For all other *diaphragms*, the *applicable building code* or *rational engineering analysis* is required.

The *required strength* of *chords*, *collectors* and other *components* and *connections* in the *diaphragm* is addressed within the *applicable building code* and within the *seismic force-resisting systems* detailed in Chapter E.

F1.4 Shear Strength

The *Standard* provides limited guidance on determining the nominal in-plane shear strength of *diaphragms* and defers to engineering analysis. An exception to this is *cold-formed steel* framed *diaphragms* with *wood structural panels*, which are handled explicitly in Section F2. In addition, for profiled steel *diaphragms*, AISI 310 (AISI, 2013) is appropriate. For all other *diaphragms*, the *nominal strength* should be determined by engineering analysis appropriate to the potential *limit states* of the *diaphragm*. The *available strength* depends on the *limit state* and in general should follow the reliability principles outlined in AISI S100 (AISI, 2012) Chapter F.

F2 Cold-Formed Steel Diaphragms Sheathed With Wood Structural Panels

F2.1 Scope

See AISI S240 Section B5.4.2.3 for additional discussion.

F2.2 Additional Design Requirements

Since the *diaphragm* does have an impact on the overall seismic *lateral force-resisting system*, the *Standard* recognizes two classes of detailing: conventional and seismic. Conventional detailing is allowed for $R \leq 3$ structures, while seismic detailing (per *Standard* Section F2.5) is required for $R > 3$ systems. The seismic detailing requirements of *Standard* Section F2.5 are not extensive and the engineer is encouraged to meet these requirements even for conventional construction.

F2.3 Required Strength

[Reserved]

F2.4 Shear Strength

F2.4.1 Nominal Strength

For *diaphragms* sheathed with *wood structural panels*, the *nominal strength* may be determined by Table F2.4-1 which is based on work by Lum (LGSEA, 1998). Lum developed ASD design tables using an analytical method outlined by Tissell (APA, 1993; APA 2000) for wood framing and the provisions of the 1991 NDS (AFPA, 1991). Since steel is not affected by splitting or tearing when fasteners are closely spaced, no reduction in the calculated strength was taken for closely spaced fasteners. In addition, although steel with designation thicknesses greater than 33 mil resulted in higher strength values, no increase in strength was included for these greater thicknesses.

It should be noted that flat *strap* used as *blocking* to transfer shear forces between sheathing panels is permitted, but is not required to be attached to framing members.

It should be noted that the *diaphragm* design values by Lum were based on the *nominal*

strength of a No. 8 screw attaching wood structural panels to 33-mil cold-formed steel framing members. The 1991 NDS calculation methodology, which was used by Lum, yielded a nominal strength of 372 lb and a safety factor of 3.3. However, the NDS methodology was revised in 2001, and the revision greatly reduced the calculated strength of screw connections. Until Lum's work is updated, justification for maintaining the current diaphragm design values in the *Standard* are based, in part, on tests performed by APA (APA, 2005). Test results for single-lap shear tests for a No. 8 screw attaching ½ in. plywood to 68-mil steel sheet sheathing indicated that the nominal strength [resistance] of the connection was governed by the strength of the screw in the steel sheet sheathing; i.e., the wood structural panels did not govern the capacity. Therefore, for thinner steel sheet sheathing, the limit state would likely be the tilting and bearing failure mode. For a No. 8 screw installed in 33-mil steel sheet sheathing, computations of connection capacity in accordance with AISI S100 [CSA S136] would yield a nominal strength of 492 lb and a safety factor of 3.0. Additionally, connection tests for plywood attached to 33-mil cold-formed steel framing members were performed by Serrette (1995b) and produced an average ultimate connection capacity of 1177 lb, and Serrette suggested the use of a safety factor of 6, as given by APA E380D. A review of the allowable strengths, as summarized in Table C-F2.4.1-1 below, indicates that although Lum's design values are based on an earlier edition of the NDS, the value is conservative when compared to both AISI's and Serrette's results.

Table C-F2.4.1-1
No. 8 Screw Shear Strength (lb) for 33-mil Cold-Formed Steel Member

Lum		AISI 2001		Serrette	
Nominal	Allowable	Nominal	Allowable	Nominal	Allowable
372	112	492	164	1177	196

F2.4.2 Available Strength

The safety and resistance factors employed are based on engineering judgment in comparison with steel diaphragms from AISI S100 (AISI, 2012) at the time of the creation of the first edition of AISI S213 (AISI, 2007b), a precursor to this *Standard*.

F2.4.3 Design Deflection

Deflection expressions are provided in AISI S240 Section B5.4.4.1 and are repeated here for convenience. The deflection of a blocked diaphragm sheathed with wood structural panels is permitted to be determined in accordance with the following:

$$\delta = \frac{0.052vL^3}{E_s A_c b} + \omega_1 \omega_2 \frac{vL}{\rho G t_{\text{sheathing}}} + \omega_1^{5/4} \omega_2 (\alpha) \left(\frac{v}{2\beta} \right)^2 + \frac{\sum_{j=1}^n \Delta_{ci} X_i}{2b} \quad (\text{Eq. C-F2.4.3-1})$$

where

- A_c = Gross cross-sectional area of chord member, in². (mm²)
- b = Diaphragm depth parallel to direction of load, in in. (mm)
- E_s = Modulus of elasticity of steel
= 29,500,000 psi (203,000 MPa)
- G = Shear modulus of sheathing material, in lb/in.² (MPa)

- L = Diaphragm length perpendicular to direction of load, in in. (mm)
 n = Number of chord splices in diaphragm (considering both diaphragm chords)
 s = Maximum fastener spacing at panel edges, in in. (mm)
 $t_{\text{sheathing}}$ = Nominal panel thickness, in in. (mm)
 t_{stud} = Nominal stud thickness, in in. (mm)
 v = Shear demand, in lb/ in. (N/mm)
 $\quad = V/(2b)$ (Eq. C-F2.4.3-2)
 V = Total lateral load applied to the diaphragm, in lb (N)
 X_i = Distance between the “ith” chord-splice and the nearest support (braced wall line), in in. (mm)
 α = Ratio of the average load per fastener based on a non-uniform fastener pattern to the average load per fastener based on a uniform fastener pattern (= 1 for a uniformly fastened diaphragm)
 β = 67.5 for plywood other than Canadian Soft Plywood (CSP)
 $\quad = 55$ for OSB and CSP for U.S. Customary Units (lb/in^{1.5})
 $\quad = 2.35$ for plywood other than CSP
 $\quad = 1.91$ for OSB for SI units (N/mm^{1.5}).
 δ = Calculated deflection, in in. (mm)
 Δ_{ci} = Deformation value associated with “ith” chord splice, in in. (mm)
 ρ = 1.85 for plywood other than CSP
 $\quad = 1.05$ for OSB and CSP
 ω_1 = $s/6$ (for s in in.) (Eq. C-F2.4.3-3a)
 $\quad = s/152.4$ (for s in mm) (Eq. C-F2.4.3-3b)
 ω_2 = $0.033/t_{\text{stud}}$ (for t_{stud} in in.) (Eq. C-F2.4.3-4a)
 $\quad = 0.838/t_{\text{stud}}$ (for t_{stud} in mm) (Eq. C-F2.4.3-4b)

The above equation applies to uniformly nailed, blocked diaphragms with a maximum framing spacing of 24 inches (610 mm) on center. For unblocked diaphragms, the deflection must be multiplied by 2.50 (APA, 2001). If not uniformly nailed, the constant 0.188 (For SI: 1/1627) in the third term must be modified accordingly.

In 2012, coefficients β and ρ in deflection Equation C-E2.4.3-1 were revised based on research work by Cobeen (2010). Based on shear wall performance, similar revisions were made to the deflection Equation C-F2.4.3-1 for the diaphragm systems.

F2.5 Requirements Where Seismic Response Modification Coefficient, R , Greater Than Three

To limit torsion, this Standard limits application to open front structures. Also, to avoid narrow panels that are unable to develop adequate shear behavior due to their aspect ratio, a minimum panel width is required.

F3 Other Diaphragms

[Reserved]

G. QUALITY CONTROL AND QUALITY ASSURANCE

For relevant commentary on quality control and quality assurance for the *seismic force-resisting systems* in this *Standard*, see Chapter D of AISI S240 and AISI 220, *Code of Standard Practice for Cold-Formed Steel Framing*. All seismic force-resisting systems in this *Standard* have detailed system requirements to ensure the system can provide the necessary ductility and assumed overstrength. In some cases the system requirements depart from conventional construction; particularly, for regions that are not commonly controlled by seismic design. For example, *chord studs on shear walls* are critical *components* that must not be modified, even if providing double duty as a jamb for an opening in addition to a *chord stud*. Also, the requirement that all fasteners be driven flush is a unique requirement and underlines the care that should be taken in constructing *seismic force-resisting systems*. Even though in many cases the *seismic-force resisting system* does not visually appear drastically different from a conventional gravity wall, it is different in function and necessity for the engineering system, and it is important that actual system requirements of this *Standard* be enforced during construction.

Additional quality assurance and quality control procedures are provided for the *Cold-Formed Steel Special Bolted Moment Frame (CFS-SBMF)* system of Section E4, which is unique to seismic design. *Snug-tightened bolts* are specified, as is customary for this type of construction. However, a departure from traditional practice is to require that the bolt tightness be checked on a representative sample of bolts. This is because a modest level of tightness is required to develop the expected level of slip resistance in the *connections*. An ordinary spud wrench is used to make this check. It should be noted that fully pretensioned bolts, such as is required in slip-critical *connections* in heavier construction, are not suitable for *cold-formed steel* structural systems. The higher levels of tensioning for those applications are usually controlled by the turn-of-nut method, but the rotations specified are not applicable to *cold-formed steel* because they are based on greater grip lengths than those typically encountered with the thinner material. The turn-of-nut and other methods are outlined by the Research Council on Structural Connections.

H. USE OF SUBSTITUTE COMPONENTS AND CONNECTIONS IN SEISMIC FORCE-RESISTING SYSTEMS

For a number of years, evaluation services have issued product evaluation reports that advised building officials that specific manufactured products were acceptable as substitutes for structural *components* comprising portions of *seismic force-resisting systems* with specific code-specified design and detailing criteria. These evaluation service reports were typically based on a comparison of hysteretic test data for the proposed product and also for limited sets of available data on the performance of code-conforming systems. Such evaluation service reports have been issued for special steel moment resisting *connections*, proprietary *shear wall* products intended for use in light frame construction, and other technologies.

While the evaluation services have attempted to perform impartial and meaningful evaluations of the effect of *component* substitution on system response, there has not been any consensus basis as to appropriate means of judging the adequacy of a substitute component's performance capability or the bounds under which its use should be permitted. Recently, FEMA P795 (2011) was published. This methodology uses an extensive database on the effects of changes in certain hysteretic response parameters, including stiffness, peak strength and ultimate deformation capacity, on overall system response and collapse resistance. The methodology then applies statistical methods to characterize the ability of structures incorporating the substitute *components* to apply equivalent or better resistance to collapse than structures incorporating code-specified *components*, considering uncertainties associated with the quantity and quality of available laboratory test data used to characterize the performance of conforming and substitute *components*. This methodology is deemed to comprise a preferred means of demonstrating the acceptability of *component* substitution in the structural systems covered in this *Standard*.

This Page is Intentionally Left Blank.

APPENDIX 1, SEISMIC FORCE MODIFICATION FACTORS AND LIMITATIONS IN CANADA

NBCC adoption cycles do not always allow for the latest research to be incorporated. Therefore, for solutions not yet incorporated into NBCC, this section provides additional guidance on *seismic force modification factors*. These values are only intended for use in Canada, and only when the NBCC does not contain such values.

REFERENCES

- AFPA (1991), *National Design Specification for Wood Construction*, American Forest and Paper Association, Washington, DC, 1991.
- AFPA (2001), *Manual for Engineered Wood Construction, Wood Structural Panels Supplement*, American Forest and Paper Association, Washington, DC, 2001.
- AFPA (2005a), *National Design Specification for Wood Construction*, American Forest and Paper Association, Washington, DC, 2005.
- AFPA (2005b), *Special Design Provisions for Wind and Seismic*, SDPWS-2005, American Forest and Paper Association, Washington, DC, 2005.
- AWC (2015), *National Design Specification for Wood Construction*, American Wood Council, Leesburg, VA, 2015.
- AISC (2005), *Seismic Provisions for Structural Steel Buildings*, ANSI/AISC 341-05, American Institute of Steel Construction, Chicago, IL, 2005.
- AISC (2010), *Seismic Provisions for Structural Steel Buildings*, ANSI/AISC 341-10, American Institute of Steel Construction, Chicago, IL, 2010.
- AISI (2007a), *North American Specification for the Design of Cold-Formed Steel Structural Members*, AISI S100-07, American Iron and Steel Institute, Washington, DC, 2007.
- AISI (2007b), *North American Standard for Cold-Formed Steel Framing – Lateral Design*, AISI S213-07, American Iron and Steel Institute, Washington, DC, 2007.
- AISI (2015), *Code of Standard Practice for Cold-Formed Steel Framing*, AISI S202-11, American Iron and Steel Institute, Washington, DC, 2015.
- AISI (2012), *North American Specification for the Design of Cold-Formed Steel Structural Members*, AISI S100-12, American Iron and Steel Institute, DC, 2012.
- AISI (2012b), *Standard for Cold-Formed Steel Framing – Prescriptive Method for One- and Two-Family Dwellings (Reaffirmed 2012)*, AISI S230-07 (2012), American Iron and Steel Institute, Washington, DC, 2012.
- AISI (2013), *North American Standard for the Design of Profiled Steel Diaphragm Panels*, American Iron and Steel Institute, Washington, DC, 2013.
- Al-Kharat, M. and C.A. Rogers (2005), "Testing of Light Gauge Steel Strap Braced Walls," Research Report, Department of Civil Engineering and Applied Mechanics, McGill University, Montreal, Quebec, Canada, 2005.
- Al-Kharat, M. and C.A. Rogers (2006), "Inelastic Performance of Screw Connected Light Gauge Steel Strap Braced Walls," Research Report, Department of Civil Engineering and Applied Mechanics, McGill University, Montreal, Quebec, Canada, 2006.
- Al-Kharat, M. and C.A. Rogers (2007), "Inelastic Performance of Cold-Formed Steel Strap Braced Walls," *Journal of Constructional Steel Research*, 63(4), 460-474, 2007.
- APA (1993), *Wood Structural Panel Shear Walls*, Report 154, APA-The Engineered Wood Association, Tacoma, WA, 1993.
- APA (2000), *Plywood Diaphragms*, Report 138, APA-The Engineered Wood Association, Tacoma, WA, 2000.
- APA (2001), *Diaphragms and Shear Walls: Design/Construction Guide*, APA-The Engineered Wood Association, Tacoma, WA, 2001.

- APA (2005), *Fastener Loads for Plywood - Screws*, Technical Note E380D, APA-The Engineered Wood Association, Tacoma, WA, 2005.
- ASCE (2006), *Minimum Design Loads for Buildings and Other Structures*, ASCE 7-05 Including Supplement No. 1, American Society of Civil Engineers, Reston, VA, 2006.
- ASCE (2010), *Minimum Design Loads for Buildings and Other Structures*, ASCE/SEI 7-10 with Supplement 1-12, American Society of Civil Engineers, Reston, VA, 2010.
- ASTM (2002), *Standard Specification for Steel Sheet, Zinc-Coated (Galvanized) or Zinc-Iron Alloy-Coated (Galvannealed) by the Hot-Dip Process*, ASTM A653/A653M-02a, ASTM International, West Conshohocken, PA, 2005.
- ASTM (2005), *Standard Test Methods for Cyclic (Reversed) Load Test for Shear Resistance of Walls for Buildings*, ASTM E2126-05, ASTM International, West Conshohocken, PA, 2005.
- ASTM (2009), *Standard Test Methods and Definitions for Mechanical Testing of Steel Products*, ASTM A370, ASTM International, West Conshohocken, PA, 2009.
- ATC (1995), "Structural Response Modification Factors," ATC-19 Report, Applied Technology Council, Redwood City, CA, 1995.
- AWS (1998), *Structural Welding Code – Sheet Steel*, ANSI/AWD D1.3-98, American Welding Society, Miami, FL.
- AWS (2006), *Structural Welding Code – Steel*, ANSI/AWD D1.1/D1.1M-06, American Welding Society, Miami, FL.
- Balh, N., J. DaBreo, C. Ong-Tone, K. El-Saloussy, C. Yu, C.A. Rogers (2014), "Design of Steel Sheathed Cold-Formed Steel Framed Shear Walls," *Thin-Walled Structures*, 75: 76-86.
- Blais, C. (2006), "Testing and Analysis of Light Gauge Steel Frame / 9mm OSB Panel Shear Walls," M.Eng. Thesis, Department of Civil Engineering and Applied Mechanics, McGill University, Montreal, Quebec, Canada, 2006.
- Boudreault, F.A. (2005), "Seismic Analysis of Steel Frame/Wood Panel Shear Walls," M.Eng. Thesis, Department of Civil Engineering and Applied Mechanics, McGill University, Montreal, Quebec, Canada, 2005.
- Boudreault, F.A., C. Blais and C.A. Rogers (2007), "Seismic Force Modification Factors for Light-Gauge Steel-Frame – Wood Structural Panel Shear Walls," *Canadian Journal of Civil Engineering*, 34(1), 56-65, 2007.
- Branston, A.E., F.A. Boudreault, C.Y. Chen and C.A. Rogers (2006a), "Light-Gauge Steel-Frame – Wood Structural Panel Shear Wall Design Method," *Canadian Journal of Civil Engineering* 33(7), 872-889, 2006.
- Branston, A.E., C.Y. Chen, F.A. Boudreault and C.A. Rogers (2006b), "Testing of Light-Gauge Steel-Frame – Wood Structural Panel Shear Walls," *Canadian Journal of Civil Engineering* 33(5), 561-572, 2006.
- Brockenbrough, R. L. (2003), "MTR Survey of Plate Material Used in Structural Fabrication," *Engineering Journal*, AISC.
- Chen, C.Y. (2004), "Testing and Performance of Steel Frame/Wood Panel Shear Walls," M.Eng. Thesis, Department of Civil Engineering and Applied Mechanics, McGill University, Montreal, Quebec, Canada, 2004.

- Chen, C.Y., F.A. Boudreault, A.E. Branston and C.A. Rogers (2006), "Behaviour of Light-Gauge Steel-Frame – Wood Structural Panel Shear Walls," *Canadian Journal of Civil Engineering*, Vol. 33, No. 5, 573-587, 2006.
- Cobeen, K. (2010), *Cold-Formed Steel Framing Seismic Design Optimization Phase 1a: Seismic Equivalency Parameter Evaluation*, American Iron and Steel Institute Research Report RP10-4, Washington, DC, 2010.
- Comeau, G. and C.A. Rogers, (2008), "Inelastic Performance of Welded Strap Braced Walls," M.Eng. Thesis, Department of Civil Engineering and Applied Mechanics, McGill University, Montreal, Quebec, Canada, 2008.
- Crawford, S.F. and G.L. Kulak (1971), "Eccentrically Loaded Bolted Connections," *Journal of the Structural Division*, ASCE, Vol. 97, ST3, pp. 765-783.
- CSA (1981), CSA-S408, *Guidelines for the Development of Limit States Design*, Canadian Standards Association, Mississauga, Ontario, Canada, 1981.
- CSA (2001), CAN/CSA-O86, *Engineering Design in Wood*, Canadian Standards Association, Mississauga, Ontario, Canada, 2001.
- CSA (2003a), CSA-O151-78 (R2003), *Canadian Softwood Plywood*, Canadian Standards Association, Mississauga, Ontario, Canada, 2003.
- CSA (2003b), CSA-O121-78 (R2003), *Douglas Fir Plywood*, Canadian Standards Association, Mississauga, Ontario, Canada, 2003.
- CSA (2003c), CAN/CSA-O325.0-92 (R2003), *Construction Sheathing*, Canadian Standards Association, Mississauga, Ontario, Canada, 2003.
- CSA (2005), CAN/CSA S16S1-05, *Limit States Design of Steel Structures*, Canadian Standards Association, Mississauga, Ontario, Canada, 2005.
- DaBreo, J., N. Balh, C. Ong-Tone, C.A. Rogers (2014), "Steel Sheathed Cold-Formed Steel Framed Shear Walls Subjected to Lateral and Gravity Loading," *Thin-Walled Structures*, 74: 232-245.
- Dolan, J.D. (1999), "Monotonic and Cyclic Tests of Long Steel-Frame Shear Walls With Openings," Report No. TE-1999-001, Virginia Polytechnic Institute and State University, Blacksburg, VA, 1999.
- Dolan, J.D. and W.S. Easterling (2000a), "Monotonic and Cyclic Tests of Light-Frame Shear Walls with Various Aspect Ratios and Tie-Down Restraints," Report No. TE-2000-001, Virginia Polytechnic Institute and State University, Blacksburg, VA, 2000.
- Dolan, J.D. and W.S. Easterling (2000b), "Effect of Anchorage and Sheathing Configuration on the Cyclic Response of Long Steel-Frame Shear Walls," Report No. TE-2000-002, Virginia Polytechnic Institute and State University, Blacksburg, VA, 2000.
- FEMA (2011), FEMA P-795, *Quantification of Building Seismic Performance Factors: Component Equivalency Methodology*, Federal Emergency Management Agency, Washington, DC, 2011.
- Foliente, G.C. (1996), "Issues in Seismic Performance Testing and Evaluation of Timber Structural Systems," *Proceedings of the International Wood Engineering Conference*, Vol. 1, 29 - 36, New Orleans, LA, 1996.
- Foschi, R.O., et al. (1989), "Reliability-Based Design of Wood Structures," Structural Research Series, Report No. 34, University of British Columbia, Vancouver, BC, Canada, 1989.

- Hikita, K. (2006), "Impact of Gravity Loads on the Lateral Performance of Light Gauge Steel Frame/Wood Panel Shear Walls," M. Eng. Thesis, Department of Civil Engineering and Applied Mechanics, McGill University, Montreal, Quebec, Canada, 2006.
- Hong, J.K. and C.M. Uang (2004), "Cyclic Testing of Cold-Formed Steel Moment Connection for Pre-Fabricated Mezzanines," Report No. TR-04/03, University of California, San Diego, La Jolla, CA.
- ICBO (1994), *Uniform Building Code*, International Conference of Building Officials, Whittier, CA, 1994.
- ICBO (1997), *Uniform Building Code*, International Conference of Building Officials, Whittier, CA, 1997.
- ICC (2003), *International Building Code*, International Code Council, Falls Church, VA, 2003.
- ICC (2006), *International Building Code*. International Code Council Inc. Whittier, CA.
- LGSEA (1998), *Lateral Load Resisting Elements: Diaphragm Design Values*, Tech Note 558b-1, Light Gauge Steel Engineers Association, Washington, DC, 1998.
- Liu, J. (2013), "Updates to Expected Yield and Tensile Strength Ratio," Purdue University, 2013.
- Liu, J., R. Sabelli, R. L. Brockenbrough, T. P. Fraser (2007), "Expected Yield Stress and Tensile Strength Ratios for Determination of Expected Member Capacity in the 2005 AISC Seismic Provisions," *Engineering Journal*, AISC.
- Krawinkler, H., et al. (2000), "Development of a Testing Protocol for Wood frame Structures," Report W-02, CUREE/Caltech Wood frame Project, Richmond, CA, 2000.
- Mirzaei, A., R.H. Sangree, K. Velchev, G. Comeau, N. Balh, C.A. Rogers, B.W. Schafer (2015), "Seismic Capacity-Based Design of Narrow Strap-Braced Cold-Formed Steel Shear Walls," *Journal of Constructional Steel Research*, 2015.
- Mitchell, D., et al. (2003), "Seismic Force Modification Factors for the Proposed 2005 Edition of the National Building Code of Canada," *Canadian Journal of Civil Engineering* 30(2), 308-327, 2003.
- NAHB (2005), "Cold-Formed Steel Walls with Fiberboard Sheathing Shear Wall Testing," NAHB Research Center, Upper Marlboro, MD, 2005.
- NAHB (2006), "Cyclic Testing of Fiberboard Shear Walls with Varying Aspect Ratios," NAHB Research Center, Upper Marlboro, MD, 2005.
- NEHRP (2000), *NEHRP Recommended Provisions for Seismic Regulations for New Buildings and Other Structures*, Federal Emergency Management Agency (FEMA 368/March 2001), Washington, DC, 2000.
- NFPA (2003), *NFPA 5000, Building Construction and Safety Code*, National Fire Protection Association, Quincy, MA, 2003.
- NRCC (2005), *National Building Code of Canada*, 2005 Edition, National Research Council of Canada, Ottawa, Ontario, Canada, 2005.
- NRCC (2010), *National Building Code of Canada*, 2010 Edition, National Research Council of Canada, Ottawa, Ontario, Canada, 2010.
- Park, R. (1989), "Evaluation of Ductility of Structures and Structural Assemblages from Laboratory Testing," *Bulletin of the New Zealand National Society for Earthquake Engineering* 22(3), 1989.

- PFS (1996), "Racking Load Tests for American Fiberboard Association," PFS Corporation, Madison, WI, 1996.
- Rack Manufacturers Institute (2004), *Specification for the Design, Testing and Utilization of Industrial Steel Storage Racks*, Charlotte, NC.
- Ravindra, M.K. and T.V. Galambos (1978), "Load and Resistance Factor Design for Steel," *Journal of the Structural Division*, American Society of Civil Engineers, 104(ST9), 1337-1353, 1978.
- Rokas, D. (2006), "Testing of Light Gauge Steel Frame/9.5mm CSP Panel Shear Walls," Master's Project, Department of Civil Engineering and Applied Mechanics, McGill University, Montreal, Quebec, Canada, 2006.
- Sato, A. and C.M. Uang (2007), "Development of a Seismic Design Procedure for Cold-Formed Special Bolted Frames," Report No. SSRP-07/16, University of California, San Diego, La Jolla, CA.
- SEAO (1999), "Recommended Lateral Force Requirements and Commentary," Structural Engineers Association of California, Sacramento, CA, 1999.
- Serrette, R.L. (1995a), "Shear Wall Design and Testing," *Newsletter for the Light Gauge Steel Engineers Association*, Light Gauge Steel Engineers Association, Nashville, TN, 1995.
- Serrette, R.L., et al. (1995b), "Light Gauge Steel Shear Walls—Recent Test Results," *Proceedings of the Third International Conference on Steel and Aluminum Structures*, MAS Printing Co., Istanbul, Turkey, 1995.
- Serrette, R.L. (1996), "Shear Wall Values for Light Weight Steel Framing," Final Report, Santa Clara University, Santa Clara, CA, 1996.
- Serrette, R.L. (1997), "Additional Shear Wall Values for Light Weight Steel Framing," Final Report, Santa Clara University, Santa Clara, CA, 1997.
- Serrette, R.L. (2002), "Performance of Cold-Formed Steel-Framed Shear Walls: Alternative Configurations," Final Report: LGSRG-06-02, Santa Clara University, Santa Clara, CA, 2002.
- Serrette, R., I. Lam, H. Qi, H. Hernandez and A. Toback (2006), "Cold-Formed Steel Frame Shear Walls Utilizing Structural Adhesives," *Journal of Structural Engineering*, American Society of Civil Engineers, Reston, VA, 2006.
- Serrette, R.L. and K. Chau (2003), "Estimating the Response of Cold-Formed Steel-Frame Shear Walls," Santa Clara University, Santa Clara, CA, 2003.
- Tarpy, T.S. (1980), "Shear Resistance of Steel-Stud Wall Panels," *Proceedings of the Fifth International Specialty Conference on Cold-Formed Steel Structures*, University of Missouri-Rolla, Rolla, MO, 1980.
- Tarpy, T.S. and J.D. Girard (1982), "Shear Resistance of Steel-Stud Wall Panels," *Proceedings of the Sixth International Specialty Conference on Cold-Formed Steel Structures*, University of Missouri-Rolla, Rolla, MO, 1982.
- Tarpy, T.S., and S.F. Hauenstein (1978), "Effect of Construction Details on Shear Resistance of Steel-Stud Wall Panels," Project No. 1201-412 sponsored by AISI and the Department of Civil Engineering, Vanderbilt University, Nashville, TN, 1978.
- Tarpy, T.S. and A.R. McBrearty (1978), "Shear Resistance of Steel-Stud Wall Panels with Large Aspect Ratios," Report No. CE-USS-2, Department of Civil Engineering, Vanderbilt University, Nashville, TN, 1978.

- Tarpy, T.S. and C.S. McCreless (1976), "Shear Resistance Tests on Steel-Stud Wall Panels," Department of Civil Engineering, Vanderbilt University, Nashville, TN, 1976.
- Velchev, K. and C.A. Rogers (2008), "Inelastic Performance of Screw Connected Strap Braced Walls," M.Eng. Thesis, Department of Civil Engineering and Applied Mechanics, McGill University, Montreal, Quebec, Canada, 2008.
- Wood, L. (1960), "Relation of Strength of Wood to Duration of Load," U.S. Department of Agriculture, Forest Products Laboratory, Report No. 1916, Madison, WI, 1960.
- Yanagi, N. and C. Yu (2014), "Effective Strip Method for the Design of Cold-Formed Steel Framed Shear Wall with Steel Sheet Sheathing," *ASCE Journal of Structural Engineering*, Vol. 140, No. 4, 2014.
- Yu, C. (2007), "Steel Sheet Sheathing Options for Cold-Formed Steel Framed Shear Wall Assemblies Providing Shear Resistance," Report No. UNT-G76234, Department of Engineering Technology, University of North Texas, Denton, TX, 2007.

Advisory Note: The Light Gauge Steel Engineers Association (LGSEA) changed its name to the Cold-Formed Steel Engineers Institute (CFSEI) in 2006.



**American
Iron and Steel
Institute**

25 Massachusetts Avenue NW
Suite 800
Washington, DC 20001
www.steel.org





**American
Iron and Steel
Institute**

25 Massachusetts Avenue NW
Suite 800
Washington, DC 20001
www.steel.org

