

01 Jan 2012

North American Standard for Cold-Formed Steel Framing -- Nonstructural Members, 2011 Edition

American Iron and Steel Institute

Follow this and additional works at: <https://scholarsmine.mst.edu/ccfss-aisi-spec>



Part of the [Structural Engineering Commons](#)

Recommended Citation

American Iron and Steel Institute, "North American Standard for Cold-Formed Steel Framing -- Nonstructural Members, 2011 Edition" (2012). *AISI-Specifications for the Design of Cold-Formed Steel Structural Members*. 217.

<https://scholarsmine.mst.edu/ccfss-aisi-spec/217>

This Technical Report is brought to you for free and open access by Scholars' Mine. It has been accepted for inclusion in AISI-Specifications for the Design of Cold-Formed Steel Structural Members by an authorized administrator of Scholars' Mine. This work is protected by U. S. Copyright Law. Unauthorized use including reproduction for redistribution requires the permission of the copyright holder. For more information, please contact scholarsmine@mst.edu.



AISI S220-11



AISI STANDARD

North American Standard for Cold-Formed Steel Framing – Nonstructural Members

2011 Edition

Endorsed by Steel Framing Alliance



DISCLAIMER

The material contained herein has been developed by the American Iron and Steel Institute Committee on Framing Standards. The Committee has made a diligent effort to present accurate, reliable, and useful information on cold-formed steel framing design and installation. The Committee acknowledges and is grateful for the contributions of the numerous researchers, engineers, and others who have contributed to the body of knowledge on the subject. Specific references are included in the *Commentary*.

With anticipated improvements in understanding of the behavior of cold-formed steel framing and the continuing development of new technology, this material will become dated. It is anticipated that AISI will publish updates of this material as new information becomes available, but this cannot be guaranteed.

The materials set forth herein are for general purposes only. They are not a substitute for competent professional advice. Application of this information to a specific project should be reviewed by a design professional. Indeed, in many jurisdictions, such review is required by law. Anyone making use of the information set forth herein does so at their own risk and assumes any and all liability arising therefrom.

PREFACE

The American Iron and Steel Institute Committee on Framing Standards has developed AISI S220, the *North American Standard for Cold-Formed Steel Framing – Nonstructural Members*, to address requirements for construction with *nonstructural members* made from cold-formed steel. This standard is intended for adoption and use in the United States, Canada and Mexico.

This standard provides an integrated treatment of Allowable Strength Design (ASD), Load and Resistance Factor Design (LRFD), and Limit States Design (LSD). This is accomplished by including the appropriate resistance factors (ϕ) for use with LRFD and LSD, and the appropriate factors of safety (Ω) for use with ASD. It should be noted that LSD is limited to Canada and LRFD and ASD are limited to Mexico and the United States.

The Committee acknowledges and is grateful for the contributions of the numerous engineers, researchers, producers and others who have contributed to the body of knowledge on the subjects. The Committee wishes to also express its appreciation for the support of the Steel Framing Alliance and the Canadian Sheet Steel Building Institute.

This Page is Intentionally Left Blank.

AISI COMMITTEE ON FRAMING STANDARDS

Richard Haws, <i>Chairman</i>	NUCONSTEEL
Steve Fox, <i>Vice Chairman</i>	Canadian Sheet Steel Building Institute
Helen Chen, <i>Secretary</i>	American Iron and Steel Institute
Don Allen	Steel Stud Manufacturers Association
Bill Babich	ITW Building Components Group
Jeff Brink	National Council of Structural Engineers Associations
John Butts	John F. Butts & Associates
Brad Cameron	Cameron & Associates Engineering, LLC
Randy Daudet	Simpson-Strong Tie
Nader Elhajj	FrameCAD Solutions
Curt Kinney	Super Stud Building Products
Jeff Klaiman	ADTEK Engineers
Roger LaBoube	Wei-Wen Yu Center for Cold-Formed Steel Structures
John Matsen	Matsen Ford Design Associates
Cristopher Moen	Virginia Tech
James Moses	LiteSteel Technologies America LLC
Kenneth Pagano	Scosta Corporation
Mike Pellock	Aegis Metal Framing
Nabil Rahman	The Steel Network
Gregory Ralph	ClarkDietrich Building Systems
Benjamin Schafer	Johns Hopkins University
Fernando Sesma	California Expanded Metal Products
Ryan Smith	StructureSmith LLC
Sutton Stephens	Pacific Northwest Engineering, Inc.
Thomas Trestain	T.W.J. Trestain Structural Engineering
Steven Walker	Light Gauge Steel Engineering Group, Inc.
Robert Wessel	Gypsum Association
Lei Xu	University of Waterloo
Cheng Yu	University of North Texas
Rahim Zadeh	Marino\Ware

DESIGN METHODS SUBCOMMITTEE

Roger LaBoube, <i>Chairman</i>	Wei-Wen Yu Center for Cold-Formed Steel Structures
Helen Chen, <i>Secretary</i>	American Iron and Steel Institute
Don Allen	Steel Stud Manufacturers Association
Bill Babich	ITW Building Components Group
John Butts	John F. Butts & Associates
Brad Cameron	Cameron & Associates Engineering, LLC
Nader Elhajj	FrameCAD Solutions
Jerod Faris	Keymark Engineering
Patrick Ford	Steel Framing Industry Association
Steve Fox	Canadian Sheet Steel Building Institute
Perry Green	Bechtel Power Corporation
Jeff Klaiman	ADTEK Engineers
Richard Layding	NUCONSTEEL
Yuanqi Li	Tongji University
Stephen Linch	Telling Industries
John Matsen	Matsen Ford Design Associates
Brian McGloughlin	MBA Building Supplies
Robert Paullus	National Council of Structural Engineers Associations
Mike Pellock	Aegis Metal Framing
Nabil Rahman	The Steel Network
Greg Ralph	ClarkDietrich Building Systems
Gary Rolih	Consultant
Benjamin Schafer	Johns Hopkins University
Fernando Sesma	California Expanded Metal Products
Randy Shackelford	Simpson Strong-Tie
Ryan Smith	StructureSmith LLC
Sutton Stephens	Pacific Northwest Engineering, Inc.
Thomas Trestain	T.W.J. Trestain Structural Engineering
Lei Xu	University of Waterloo
Cheng Yu	University of North Texas
Rahim Zadeh	Marino\Ware

TABLE OF CONTENTS
NORTH AMERICAN STANDARD FOR COLD-FORMED STEEL FRAMING –
NONSTRUCTURAL MEMBERS

DISCLAIMER	ii
PREFACE.....	iii
AISI COMMITTEE ON FRAMING STANDARDS	v
DESIGN METHODS SUBCOMMITTEE	vi
A. GENERAL	1
A1 Scope.....	1
A2 Definitions	1
A3 Loads and Load Combinations.....	2
A4 Material	2
A5 Corrosion Protection	2
A6 Products	3
A6.1 Base Steel Thickness.....	3
A6.2 Minimum Flange Width.....	3
A6.3 Product Designator	3
A6.4 Manufacturing Tolerances	3
A6.5 Product Identification.....	5
A7 Referenced Documents	5
B. DESIGN	7
B1 Member Design.....	7
B2 Member Condition.....	7
B2.1 Web Holes	7
B2.2 Cutting and Patching.....	8
B3 Connection Design	8
B4 Bracing.....	8
B5 Serviceability	8
C. INSTALLATION	9
D. CONNECTIONS.....	10
D1 Screw Connections	10
D1.1 Steel-to-Steel Screws	10
D1.2 Installation.....	10
D1.3 Stripped Screws	10
D1.4 Spacing and Edge Distance.....	10
D1.5 Gypsum Board.....	10
D2 Other Connections.....	10
D2.1 Other Connectors	10
D2.2 Connection to Other Materials	10
E. MISCELLANEOUS.....	11
E1 Utilities	11
E1.1 Holes	11
E1.2 Plumbing	11
E1.3 Electrical.....	11
E2 Insulation	11
E2.1 Mineral Fiber Insulation.....	11
E2.2 Other Insulation.....	11
F. TESTING.....	12

This Page is Intentionally Left Blank.

NORTH AMERICAN STANDARD FOR COLD-FORMED STEEL FRAMING – NONSTRUCTURAL MEMBERS

A. GENERAL

A1 Scope

The design and installation of *cold-formed steel nonstructural members* in buildings shall be in accordance with the provisions of this standard.

This standard applies to *nonstructural members* that comply with the following:

- 1) Member is in a steel-framed system that is limited to a transverse (out-of-plane) load of not more than 10 lb/ft² (0.48 kPa).

Exception: Pressurized air plenums, ceilings and elevator shaft enclosures are permitted to have a load of not more than 15 lb/ft² (0.72 kPa).

- 2) Member is in a steel-framed system that is limited to a superimposed axial load, exclusive of sheathing materials, of not more than 100 lb/ft (1.46 kN/m).
- 3) Member is limited to a superimposed axial load of not more than 200 lbs (0.89 kN).

In Canada: Members in walls acting as guards, as defined in the *National Building Code of Canada* (NBCC), shall be considered *structural members*.

This standard does not preclude the use of other materials, assemblies, structures, or designs not meeting the criteria herein, when the other materials, assemblies, structures or designs demonstrate equivalent performance for the intended use to those specified in this standard. Where there is a conflict between this standard and other reference documents, the requirements contained within this standard shall govern.

This standard includes Sections A through F inclusive.

A2 Definitions

In this standard, “shall” is used to express a mandatory requirement, i.e., a provision that the user is obliged to satisfy in order to comply with the standard. Provisions described as “permitted” are optional, and the election to use such provisions is at the discretion of the *registered design professional*.

Where the following terms appear in this standard in italics, such terms shall have meaning as defined herein or AISI S100 [CSA S136]. Terms included in square brackets are specific to *LSD* terminology. Where a country is indicated in square brackets following the definition, the definition shall apply only in the country indicated. Terms not defined in Section A2 shall have the ordinary accepted meaning in the context for which they are intended.

Applicable Building Code. The building code under which the building is designed.

Approved. Approved by the authority having jurisdiction or *design professional*.

Base Steel Thickness. The thickness of bare steel exclusive of all coatings.

Cold-Formed Sheet Steel. Sheet steel or strip steel that is manufactured by (1) press braking blanks sheared from sheets or cut length of coils or plates, or by (2) continuous roll forming of cold- or hot-rolled coils of sheet steel; both forming operations are performed at ambient room temperature, that is, without any addition of heat such as would be required for hot forming.

Cold-Formed Steel. See *Cold-Formed Sheet Steel*.

C-Shape. A *cold-formed steel* shape used for *structural* and *nonstructural members* consisting of

a *web*, two (2) *flanges* and two (2) *lips* (*edge stiffeners*).

Design Load. Applied load determined in accordance with either *LRFD load combinations* or *ASD load combinations*, whichever is applicable. [USA and Mexico]

Design Professional. An individual who is registered or licensed to practice their respective design profession as defined by the statutory requirements of the state, province or territory in which the project is to be constructed.

Designation Thickness. The minimum *base steel thickness* expressed in *mils* and rounded to a whole number.

Factored Load. Product of a *specified load* and appropriate load factor. [Canada]

Flange. For a *C-shape*, *U-shape* or *track*, that portion of the framing member that is perpendicular to the *web*. For a *furring channel*, that portion of the framing member that connects the *webs*.

Nonstructural Member. A member in a steel-framed system that is not a part of the gravity load resisting system, lateral force resisting system or building envelope.

Structural Member. A member that resists *design loads* [*factored loads*], as required by the *applicable building code*, except when defined as a *nonstructural member*.

Stud. A vertical framing member in a wall system or assembly.

Track. A framing member consisting of only a *web* and two (2) *flanges*. *Track web* depth measurements are taken to the inside of the *flanges*.

Web. That portion of a framing member that connects the *flanges*.

A3 Loads and Load Combinations

Steel-framed systems utilizing *nonstructural members* shall be designed in accordance with the *applicable building code*. In the absence of an *applicable building code*, the loads, forces, and combinations of loads shall be in accordance with accepted engineering practice for the geographical area under consideration as specified by the applicable sections of *Minimum Design Loads for Buildings and Other Structures* (ASCE 7) in the United States and Mexico, and the *National Building Code of Canada* (NBCC) in Canada.

A4 Material

Nonstructural members utilized in *cold-formed steel* framed construction shall be cold-formed to shape from sheet steel complying with the requirements of ASTM A1003/A1003M Type NS.

A5 Corrosion Protection

A5.1 *Nonstructural members* utilized in *cold-formed steel* framed construction shall have a protective coating conforming to ASTM A653/A653M G40 minimum or shall have a protective coating with an equivalent corrosion resistance.

A5.2 Additional corrosion protection shall not be required on edges of metallic-coated steel framing members, shop or field cut, punched or drilled.

A5.3 Framing members shall be located within the building envelope and shielded from direct contact with moisture from the ground or the outdoor climate.

A5.4 Dissimilar metals shall not be used in direct contact with *cold-formed steel* framing members unless *approved* for that application.

A5.5 *Cold-formed steel* framing members shall not be embedded in concrete unless *approved* for that application.

A5.6 Fasteners shall have a corrosion-resistant treatment, or be manufactured from material not susceptible to corrosion.

A6 Products

A6.1 Base Steel Thickness

In no case shall the minimum *base steel thickness* be less than 95% of the *design thickness*.

A6.2 Minimum Flange Width

For *C-shape* members intended to receive sheathing, the minimum *flange* width shall be 1-1/4 inch (31.8 mm). For *track*, the minimum *flange* width shall be 1 inch (25.4 mm).

A6.3 Product Designator

References to *nonstructural members* shall use a four-part product designator that identifies the size (both *web* depth and *flange* width), style, and thickness. The standard designator as described (i.e. based on U.S. Customary units) shall be used for either U.S. Customary or SI Metric units. The product designator shall consist of the following sequential codes:

A three- or four-digit numeral indicating member *web* depth in 1/100 inch. A letter indicating:

S = *Stud* or *joist* framing member which has *lips*

T = *Track* section

U = Channel or *stud* framing section which does not have *lips*

F = Furring channels

L = Angle or *L-header*

A three-digit numeral indicating *flange* width in 1/100 inch, followed by a dash. A two- or three-digit numeral indicating *designation thickness*.

A6.4 Manufacturing Tolerances

Nonstructural members utilized in *cold-formed steel* framed construction shall comply with the manufacturing tolerances listed in Table A6-1.

Table A6-1
Manufacturing Tolerances for Nonstructural Members

Dimension ¹	Item Checked	Studs, in. (mm)	Tracks, in. (mm)
A	Length	+1/8 (3.18)	+ 1(25.40)
		-1/4 (6.35)	-1/4 (6.35)
B ²	Web Depth	+1/32 (0.79)	+1/8 (3.18)
		-1/32 (0.79)	-0 (0)
C	Flare	+1/16 (1.59)	+0 (0)
	Overbend	-1/16 (1.59)	-3/16 (4.76)
D	Hole Center Width	+1/8 (3.18)	NA
		-1/8 (3.18)	NA
E	Hole Center Length	+1/4 (6.35)	NA
		-1/4 (6.35)	NA
F	Crown	+1/8 (3.18)	+ 1/8 (3.18)
		-1/8 (3.18)	- 1/8 (3.18)
G	Camber	1/32 per ft. (2.6 per m)	1/32 per ft (2.6 per m)
		1/2 max (12.7)	1/2 max (12.7)
H	Bow	1/32 per ft (2.6 per m)	1/32 per ft (2.6 per m)
		1/2 max (12.7)	1/2 max (12.7)
I	Twist	1/32 per ft (2.6 per m)	1/32 per ft (2.6 per m)
		1/2 max (12.7)	1/2 max (12.7)

¹ All measurements shall be taken not less than 1 ft (305 mm) from the end.

² Outside dimension for *stud*; inside for *track*.

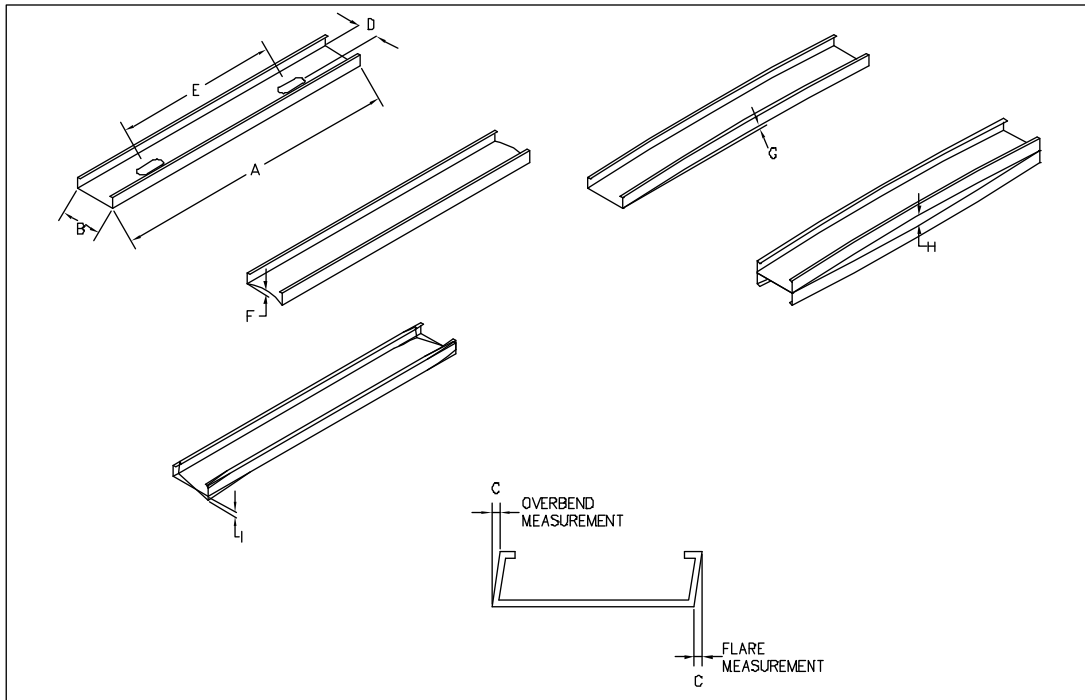

Figure A6-1 Manufacturing Tolerances for Nonstructural Members

A6.5 Product Identification

Framing members used in *cold-formed steel* framed construction shall be identified in accordance with the requirements of this section.

A6.5.1 Identification of Groups of Like Members

Groups of like members shall be marked with a label, or a tag attached thereto. Marking shall include the roll-former's identification (name, logo, or initials), length, quantity, and roll-former's member designator including member depth, flange size, minimum steel thickness in mils or inches exclusive of protective coating, and the designation "NS".

A6.5.2 Identification of Individual Framing Members

In addition to the marking referenced in A6.5.1, individual framing members shall have a legible label, stencil, or embossment at a maximum distance of 96 in. (2440 mm) on center, on the member, with the following minimum information:

- (1) The rollformer's identification (that is, name, logo, or initials).
- (2) The minimum steel thickness, in mils or inches, exclusive of protective coatings.
- (3) The minimum yield strength in kip per square inch (megapascals) if other than 33 ksi (230 MPa).
- (4) The protective coating type and weight, if other than as specified in Section A5.1.
- (5) The designation "NS".

A7 Referenced Documents

The following documents or portions thereof are referenced in this standard and shall be considered part of the requirements of this document.

1. AISI S100-07 w/S2-09, *North American Specification for the Design of Cold-Formed Steel Structural Members, 2007 Edition with Supplement No. 2*, American Iron and Steel Institute, Washington, DC.
2. ASCE 7-10, *Minimum Design Loads for Buildings and Other Structures*, American Society of Civil Engineers, Reston, VA.
3. ASTM A1003/A1003M-11, *Standard Specification for Sheet Steel, Carbon, Metallic and Non-Metallic Coated for Cold-Formed Framing Members*, ASTM International, West Conshohocken, PA.
4. ASTM C754-09a, *Standard Specification for Installation of Steel Framing Members to Receive Screw-Attached Gypsum Panel Products*, ASTM International, West Conshohocken, PA.
5. ASTM C954-10, *Standard Specification for Steel Drill Screws for the Application of Gypsum Panel Products or Metal Plaster Bases to Steel Studs From 0.033 in. (0.84 mm) to 0.112 in. (2.84 mm) in Thickness*, ASTM International, West Conshohocken, PA.
6. ASTM C1002-07, *Standard Specification for Steel Self-Piercing Tapping Screws for the Application of Gypsum Panel Products or Metal Plaster Bases to Wood Studs or Steel Studs*, ASTM International, West Conshohocken, PA.
7. ASTM C1513-10, *Standard Specification for Steel Tapping Screws for Cold-Formed Steel Framing Connections*, ASTM International, West Conshohocken, PA.
8. CAN/CSA S136-07 w/S2-09, *North American Specification for the Design of Cold-Formed Steel Structural Members, 2007 Edition with Supplement No. 2*, Canadian Standards

Association, Mississauga, Ontario, Canada.

9. NBCC 2010, *National Building Code of Canada*, 2010 Edition, National Research Council of Canada, Ottawa, Ontario, Canada.

B. DESIGN

Strength [resistance] and/or stiffness determinations for *nonstructural members* shall be in accordance with Chapter B and the requirements of AISI S100 [CSA S136] where specifically referenced herein.

B1 Member Design

Nonstructural members shall be designed either on the basis of Non-composite Assembly Design or Composite Assembly Design.

(a) Non-composite Assembly Design - Assemblies using a non-composite assembly design approach shall be designed neglecting the composite-action contribution of the attached sheathings and based on either:

(i) Chapters A through E of AISI S100 [CSA S136] with:

$$\Omega_N = 0.9 \Omega$$

$$\phi_N = 1.1 \phi$$

where

Ω = Safety factor per relevant section of AISI S100 [CSA S136]

ϕ = Resistance factor per relevant section of AISI S100 [CSA S136]

(ii) Chapter F of AISI S100 [CSA S136] with:

$$\beta_o = 1.6$$

where

β_o = Target Reliability Index in accordance with Section F1.1(b) of AISI S100 [CSA S136]

Ω = Safety factor per Section F1.2 of AISI S100 [CSA S136]

ϕ = Resistance factor per Section F1.1(b) of AISI S100 [CSA S136]

If Section A1.2(b) of AISI S100 [CSA S136] is utilized then supplementary tests are permitted to be performed and Chapter F of AISI S100 [CSA S136] is permitted to be employed for determination of Ω or ϕ , with P_m replaced by $P_{test}/P_{compute}$ and β_o in accordance with the provisions above.

In the use of AISI S100 [CSA S136] Chapter F, the professional factor, P , shall be the test-to-predicted ratio where the prediction is that of the rational engineering analysis method selected, P_m is the mean of P and V_P , the coefficient of variation of P . At least three tests shall be conducted.

(b) Composite Assembly Design - Assemblies using a composite assembly design approach shall be designed based on the tests undertaken and evaluated in accordance with Chapter F of this standard.

B2 Member Condition

Framing members shall be as specified by an *approved* design or *approved* design standard. The members shall be in good condition. Damaged members shall be replaced or repaired in accordance with the *approved* design or *approved* design standard.

B2.1 Web Holes

Holes in *webs* of framing members shall be in conformance with an *approved* design or an *approved* design standard. *Webs* with holes not conforming to the above shall be reinforced or patched in accordance with an *approved* design or *approved* design standard.

B2.2 Cutting and Patching

All cutting of framing members shall be done by sawing, abrasive cutting, shearing, plasma cutting or other *approved* methods.

B3 Connection Design

Connections shall be designed in accordance with AISI S100 [CSA S136] or testing in accordance with Section F1 of AISI S100 [CSA S136], and the requirements of Chapter D.

B4 Bracing

Bracing, when required, shall be designed in accordance with AISI S100 [CSA S136] or testing in accordance with Section F1 of AISI S100 [CSA S136].

B5 Serviceability

Serviceability limits shall be chosen based on the intended functions of the assembly, and shall be evaluated using load and load combinations in accordance with Section A3 of this standard.

C. INSTALLATION

Installation of *nonstructural members* shall be in accordance with ASTM C754.

D. CONNECTIONS

D1 Screw Connections

D1.1 Steel-to-Steel Screws

Screw fasteners for steel-to-steel connections shall be in compliance with ASTM C1513 or an *approved* design or *approved* design standard. Use of a larger than specified screw size shall be permitted, providing that the design and installation is in accordance with the minimum spacing and edge distance requirements.

D1.2 Installation

Screw fasteners shall extend through the steel connection a minimum of three (3) exposed threads. Screw fasteners shall penetrate individual components of connections without causing permanent separation between components.

D1.3 Stripped Screws

Stripped screw fasteners in direct tension shall be considered ineffective. Stripped screw fasteners in shear shall only be considered effective when the number of stripped screw fasteners considered effective does not exceed 25% of the total number of screw fasteners considered effective in the connection.

D1.4 Spacing and Edge Distance

For screw fasteners in steel-to-steel connections to be considered fully effective, the minimum center-to-center spacing and edge distance shall be 3 times the nominal diameter, except where the edge is parallel to the direction of the applied force the minimum edge distance of screw fasteners shall be 1.5 times the nominal diameter. Where the minimum center-to-center spacing is 2 times the nominal diameter, screw fasteners shall be considered 80 percent effective.

D1.5 Gypsum Board

Gypsum board shall be attached to *cold-formed steel* framing in accordance with the *applicable building code* or an *approved* design standard. Screw fasteners for gypsum board to steel connections shall be in compliance with ASTM C954, ASTM C1002, or ASTM C1513, as applicable, with a bugle head style.

D2 Other Connections

D2.1 Other Connectors

Other types of connections shall be designed, fabricated and installed in accordance with the design requirements as set forth by an *approved* design or *approved* design standard, and the fastener manufacturer's requirements.

D2.2 Connection to Other Materials

Fasteners used to connect *cold-formed steel* framing to wood, masonry, concrete or other steel components shall be designed and installed in accordance with the *applicable building code*, an *approved* design or *approved* design standard.

E. MISCELLANEOUS

E1 Utilities

E1.1 Holes

Holes shall comply with the requirements specified in Section B2.1. Penetrations of floor, wall and ceiling/roof assemblies which are required to have a fire resistance rating shall be protected in accordance with the *applicable building code* or in accordance with the requirements as stipulated by the authority having jurisdiction.

E1.2 Plumbing

All piping shall be provided with an isolative non-corrosive system to prevent galvanic action or abrasion between framing members and piping.

E1.3 Electrical

Wiring not enclosed in metal conduit shall be separated from the framing members by non-conductive non-corrosive grommets or by other *approved* means.

E2 Insulation

E2.1 Mineral Fiber Insulation

Mineral fiber insulation (e.g. rock wool, glass fiber, etc.) for installation within cavities of framing members shall be full-width type insulation and shall be installed in accordance with the requirements as set forth by the *applicable building code* and insulation manufacturer. Compression of the insulation shall be permitted to occur at the open side of the *C-shaped* framing member.

E2.2 Other Insulation

Other types of insulation (e.g. foams, loose fill, etc.) for installation within cavities of framing members shall be installed in accordance with the *applicable building code* and insulation manufacturer's requirements. The width of insulation shall be dimensionally compatible with the *cold-formed steel* framing.

F. TESTING

Tests, when required by Section B1 of this standard, shall be in accordance with an *approved* test method and Section F1 of AISI S100 [CSA S136], and conducted under the supervision of a *design professional*.



AISI STANDARD

Commentary on North American Standard for Cold-Formed Steel Framing – Nonstructural Members

2011 Edition

Endorsed by Steel Framing Alliance



DISCLAIMER

The material contained herein has been developed by the American Iron and Steel Institute Committee on Framing Standards. The Committee has made a diligent effort to present accurate, reliable, and useful information on cold-formed steel framing design and installation. The Committee acknowledges and is grateful for the contributions of the numerous researchers, engineers, and others who have contributed to the body of knowledge on the subject. Specific references are included in this *Commentary*.

With anticipated improvements in understanding of the behavior of cold-formed steel framing and the continuing development of new technology, this material will become dated. It is anticipated that AISI will publish updates of this material as new information becomes available, but this cannot be guaranteed.

The materials set forth herein are for general purposes only. They are not a substitute for competent professional advice. Application of this information to a specific project should be reviewed by a design professional. Indeed, in many jurisdictions, such review is required by law. Anyone making use of the information set forth herein does so at their own risk and assumes any and all liability arising therefrom.

1st Printing – January 2012

Copyright American Iron and Steel Institute 2012

PREFACE

This *Commentary* is intended to facilitate the use and provide an understanding of the background of AISI S220, the *North American Standard for Cold-Formed Steel Framing - Nonstructural Members*. The *Commentary* illustrates the substance and limitations of the various provisions of the standard.

In the *Commentary*, sections, equations, figures, and tables are identified by the same notation as used in the standard. Words that are italicized are defined in the standard. Terms included in square brackets are specific to LSD terminology.

This Page is Intentionally Left Blank.

TABLE OF CONTENTS
COMMENTARY ON THE
NORTH AMERICAN STANDARD FOR COLD-FORMED STEEL FRAMING –
NONSTRUCTURAL MEMBERS

DISCLAIMER **i**

PREFACE..... **iii**

A. GENERAL **1**

 A1 Scope..... 1

 A3 Loads and Load Combinations..... 1

B. DESIGN **2**

 B1 Member Design..... 2

 B5 Serviceability 2

C. INSTALLATION **3**

D. CONNECTIONS..... **4**

 D1 Screw Connections 4

F. TESTING **5**

REFERENCES..... **6**

This Page is Intentionally Left Blank.

COMMENTARY ON THE NORTH AMERICAN STANDARD FOR COLD-FORMED STEEL FRAMING – NONSTRUCTURAL MEMBERS

A. GENERAL

A1 Scope

AISI S220 (AISI, 2011) was developed in 2011 to help clearly delineate and eliminate confusion between the requirements for *cold-formed steel structural members* and *nonstructural members*. As such, provisions formerly in AISI S200 (AISI, 2007) for material, corrosion protection, base steel thickness, product designators, manufacturing tolerances, product identification, member design, member condition, installation, connections, and miscellaneous for *nonstructural members* were moved to AISI S220. However, use of the more stringent requirements for *structural members* that are in AISI S200 for *nonstructural members* should be permitted, since these should demonstrate equivalent performance for the intended use to those specified in this standard.

AISI S220 is based on the premise that the consequence of failure for a *nonstructural member* is less than for a *structural member* and, consequently, permits a lower reliability for *nonstructural members*.

Section A2 of AISI S220 defines *nonstructural members* as members in a steel-framed system that are not a part of the gravity load resisting system, primary lateral force resisting system or building envelope. Section A1 of AISI S220 defines the applicability of the standard based on transverse (out-of-plane) and superimposed axial loads. Examples of *nonstructural members* include, but are not limited to, studs in interior nonload-bearing walls and furring members.

In Canada: Walls acting as “guards” are defined as walls where the floor elevation on one side of a wall, including a wall around a shaft, is more than 600 mm higher than the floor or ground on the other side.

AISI S220 provides design methods for cases where the composition and configuration of *cold-formed steel nonstructural members* is such that calculation of strength [resistance] and/or stiffness cannot be made in accordance with the design rules in AISI S100 [CSA S136] (AISI, 2009; CSA, 2009). In order to afford a consistent range of design options, AISI S220 is also applicable to those cases where the composition and configuration of *cold-formed steel nonstructural members* is such that calculation of strength [resistance] and/or stiffness could be made in accordance with the design rules in AISI S100 [CSA S136].

A3 Loads and Load Combinations

Currently, ASCE 7 (ASCE, 2010) has no geographical-based information on Mexico. Therefore, users with projects in Mexico should work with the appropriate authority having jurisdiction to determine appropriate loads and load combinations that are consistent with the assumptions and rationale used by ASCE 7.

B. DESIGN

Because of the diverse forms in which *cold-formed steel nonstructural members* can be used (e.g., rolled-in web stiffeners, embossments, etc.), it is not possible to cover all compositions and configurations by the design rules in AISI S100 [CSA S136]. AISI S220 provides methods for such cases. AISI S220 also provides alternative methods that are permitted even for those cases where the composition and configuration of *cold-formed steel nonstructural members* is such that calculation of strength [resistance] and/or stiffness could be made in accordance with the design rules in AISI S100 [CSA S136].

B1 Member Design

AISI S220 permits the design of wall *studs* to be based on either a Non-composite Assembly Design or a Composite Assembly Design.

In the case of Non-composite Assembly Design, AISI S220 prescribes adjustments to the target reliability index, safety factor and resistance factor per AISI S100 [CSA S136] due to the reduced consequence of failure inherent in such systems that are lightly loaded and not a part of the gravity load resisting system, lateral force resisting system or building envelope. AISI S100 [CSA S136] establishes that where members do not meet the requirements for calculation in AISI S100 [CSA S136], performance may be established from one of two methods: Section A1.2(a) using tests, or Section A1.2(b) using rational engineering analysis.

Traditional ASD practice for composite interior partition wall *studs* have employed $\Omega = 1.5$; consequently, AISI S220 prescribes a 10 percent reduction on the traditional safety factor of 1.67 for flexural members. This equates to a 10 percent increase in the resistance factor when using LRFD or LSD.

For acceptable levels of variability (i.e., reasonably low V_p) this corresponds to a $\beta_o = 1.6$ (for LRFD with $M_m = 1.10$, $V_m = 0.10$, $F_m = 1.00$ and $V_F = 0.05$). Note, for this lower level of reliability, ϕ calculated per *Specification* Equation F1.1-2 may be greater than 1.0. A ϕ greater than 1.0 (just like a ϕ less than 1.0) simply reflects the necessary change in the nominal strength [resistance] such that the target reliability is achieved.

Calibration of β_o to past practice reflects that for composite interior partition wall *studs* and other *nonstructural members*, the consequence of failure is less severe than for other *structural members*. In the case of Composite Assembly Design, AISI S220 prescribes testing due to the lack of rational engineering analysis methods based upon appropriate theory and related test data.

B5 Serviceability

The ICC *International Building Code* (ICC, 2012) and *NFPA 5000: Building Construction and Safety Code* (NFPA, 2012) set forth deflection limits for use in the United States and Mexico. Likewise, the *User's Guide - NBC 2010 Structural Commentaries (Part 4, of Division B)* (NRC, 2010) sets forth deflection limits for use in Canada.

C. INSTALLATION

AISI S220 requires that the installation of *nonstructural members* be in accordance with ASTM C754 (ASTM, 2009). ASTM C754 covers the minimum requirements for the installation of interior nonstructural steel framing and furring members designed to receive screw-attached gypsum panel products. However, as stated in ASTM C754, details of construction for a specific assembly to achieve a required fire resistance need to be obtained from reports of fire-resistance tests, engineering evaluations, or listings from recognized fire testing laboratories.

ASTM C754 includes provisions for the installation of *studs*, runners (e.g., *track*), rigid furring channels, and grid suspension systems. For *stud* installation, ASTM C754 provides typical framing spacing, heights and connection requirements as well as special requirements for studs located adjacent to door and window frames, partition intersections and corners. The standard cautions that where conditions require that a partition be constructed with compensation for vertical structural movement, the gap between the end of a stud and the adjacent runner must be designed by an architect or engineer.

ASTM C754 does not address specific design conditions for members supporting interior openings, which present point loads and moments that may still allow the *stud* to meet the gravity load criteria for a *nonstructural member*, but which should be considered in design. ASTM C754 also does not address design conditions for loads imposed by such items as shelving, cabinets, fixtures or grab bars that might be attached to the wall.

D. CONNECTIONS

D1 Screw Connections

The standard requires that screw fasteners for gypsum board to steel connections be in compliance with ASTM C954 (ASTM, 2010a), ASTM C1002 (ASTM, 2007) or ASTM C1513 (ASTM, 2010b), as applicable, with a bugle head style. ASTM C954 is for fastening to steel having a thickness from 0.033 inches (0.84 mm) to 0.112 inches (2.84 mm). ASTM C1002 is for fastening to steel with a thickness less than 0.033 inches (0.84 mm). ASTM C1513 is for fastening to steel with a thickness not greater than 0.118 inches (2.997 mm).

F. TESTING

For cold-formed steel nonstructural members in interior non-load bearing wall assemblies, ICC-ES AC86, *Acceptance Criteria for Cold-Formed Steel Framing Members - Interior Nonload-Bearing Wall Assemblies* (ICC-ES, 2010), is generally an *approved* test method.

REFERENCES

- (AISI, 2007), *North American Standard for Cold-Formed Steel Framing – General Provisions*, AISI S200-07, American Iron and Steel Institute, Washington, DC, 2007.
- (AISI, 2009), *North American Specification for the Design of Cold-Formed Steel Structural Members with Supplement No. 2*, AISI S100-07 w/S2-09, American Iron and Steel Institute, Washington, DC, 2009.
- (AISI, 2011), *North American Standard for Cold-Formed Steel Framing – Nonstructural Member Design*, AISI 220-11, American Iron and Steel Institute, Washington, D.C., 2011.
- (ASCE, 2010), *Minimum Design Loads for Buildings and Other Structures*, ASCE 7-10, American Society of Civil Engineers, Reston, VA, 2010.
- (ASTM, 2007), *Standard Specification for Steel Self-Piercing Tapping Screws for the Application of Gypsum Panel Products or Metal Plaster Bases to Wood Studs or Steel Studs*, ASTM C1002-07, ASTM International, West Conshohocken, PA, 2007.
- (ASTM, 2009), *Standard Specification for Installation of Steel Framing Members to Receive Screw-Attached Gypsum Panel Products*, ASTM C754-09a, ASTM International, West Conshohocken, PA, 2009.
- (ASTM, 2010a), *Standard Specification for Steel Drill Screws for the Application of Gypsum Panel Products or Metal Plaster Bases to Steel Studs From 0.033 in. (0.84 mm) to 0.112 in. (2.84 mm) in Thickness*, ASTM C954-10, ASTM International, West Conshohocken, PA, 2010.
- (ASTM, 2010b), *Standard Specification for Steel Tapping Screws for Cold-Formed Steel Framing Connections*, ASTM C1513-10, ASTM International, West Conshohocken, PA, 2010.
- (CSA, 2009), *North American Specification for the Design of Cold-Formed Steel Structural Members, 2007 Edition with Supplement No. 2*, CAN/CSA-S136-07 w/S2-09, Canadian Standards Association, Mississauga, Ontario, Canada, 2009.
- (ICC, 2012), *International Building Code*, International Code Council, Falls Church, VA, 2012.
- (ICC-ES, 2010), *Acceptance Criteria for Cold-Formed Steel Framing Members - Interior Nonload-Bearing Wall Assemblies*, ICC-ES AC86, ICC Evaluation Service, Whittier, CA, 2010.
- (NFPA, 2012), *NFPA 5000: Building Construction and Safety Code*, National Fire Protection Association, Quincy, MA, 2012.
- (NRC, 2010), *User's Guide – NBC 2005 Structural Commentaries (Part 4, of Division B)*, National Research Council of Canada, Ottawa, Ontario, Canada, 2010.



**American
Iron and Steel
Institute**

1140 Connecticut Avenue NW
Suite 705
Washington, DC 20036
www.steel.org



Steel Framing Alliance™

1140 Connecticut Avenue NW
Suite 705
Washington, DC 20036
www.steel framing.org

