CCFSS Library (1939 - present)

Wei-Wen Yu Cold-Formed Steel Library

01 Dec 1983

Testing of steel roof deck construction

Wei-Wen Yu

Missouri University of Science and Technology, wwy4@mst.edu

Lan-Cheng Pan

S. H. Lin

Follow this and additional works at: <https://scholarsmine.mst.edu/ccfss-library>



Part of the [Structural Engineering Commons](#)

Recommended Citation

Yu, Wei-Wen; Pan, Lan-Cheng; and Lin, S. H., "Testing of steel roof deck construction" (1983). *CCFSS Library (1939 - present)*. 193.

<https://scholarsmine.mst.edu/ccfss-library/193>

This Technical Report is brought to you for free and open access by Scholars' Mine. It has been accepted for inclusion in CCFSS Library (1939 - present) by an authorized administrator of Scholars' Mine. This work is protected by U. S. Copyright Law. Unauthorized use including reproduction for redistribution requires the permission of the copyright holder. For more information, please contact scholarsmine@mst.edu.

Wei-Wen Yu
LIBRARY

Civil Engineering Study 83-8

Structural Series

Second Progress Report

TESTING OF STEEL ROOF DECK CONSTRUCTION

by

L.C. Pan S.H. Lin

Research Assistants

Wei-Wen Yu
Project Director

A Research Project Sponsored by RoofTex, Inc.

December 1983

Department of Civil Engineering
University of Missouri-Rolla
Rolla, Missouri

TABLE OF CONTENTS

	<u>Page</u>
LIST OF TABLES.....	iii
LIST OF FIGURES.....	iv
I. INTRODUCTION.....	1
II. UPLIFT PRESSURE TESTS OF INSULATED STEEL ROOF DECK ASSEMBLIES.....	2
A. Construction of the Roof System.....	2
B. Test Setup.....	2
C. Test Procedure.....	3
D. Test Results.....	4
III. CONCLUSION.....	6
IV. ACKNOWLEDGMENTS.....	6
V. REFERENCES.....	7

LIST OF TABLES

<u>Table</u>	<u>Page</u>
1 Measured Thicknesses of Steel Decks with Galvanized Finish Coating Class G-90.....	8
2a Uplift Pressure Test of Fiberglass Insulated Built-up Roof Deck System.....	8
2b Uplift Pressure Test of Gypsum Board Built-up Roof Deck System.....	9

LIST OF FIGURES

<u>Figure</u>	<u>Page</u>
1 Type N2, 22 ga. 3 in. Deep Steel Deck.....	10
2 Fiberglass Insulated Built-up Roof Deck System.....	11
3 Gypsum Board Built-up Roof Deck System.....	12
4 Angle Frame Used for the Construction of Roof Systems	13
5 Cross Sections of Roof Systems.....	14
6 Arrangements of Roofgrip Fasteners.....	15
7 Test Frame and Apparatus Used for the Uplift Pressure Test.....	16
8 Photograph of Uplift Pressure Test Setup.....	17
9 Uplift Pressure Test Setup.....	18
10 Cross Sections of Uplift Pressure Test Setup.....	19
11 Locations of Fasteners Pulled Through and Tilted....	20
12 Locations of Dismantled Roof.....	21
13 Top View of Dismantled Roof Systems.....	22
14 Flexural Failure of Steel Deck for Fiberglass Insulated Built-up Roof Deck System.....	23
15 Flexural Failure of Steel Deck for Gypsum Board Built-up Roof Deck System.....	24

I. INTRODUCTION

In recent years, insulated steel roof deck construction has been widely used in industrial and commercial buildings. The use of roof assembly consisting of 3-in. deep, 22-gage, steel deck is being considered by Rooftex, Inc. of Houston, Texas, for Class I-60 and Class I-90 assemblies.

At the request of Rooftex, two types of tests were conducted at the University of Missouri-Rolla in July 1983. These tests, which consisted of physical tests of steel roof decks and uplift pressure tests of insulated steel roof deck construction, were conducted to obtain the necessary data for the approval of the Factory Mutual Research Corporation. Descriptions of the test setups, procedures used for the tests, and the test results are included in the First Progress Report,¹

In December 1983, two additional uplift pressure tests of insulated steel roof deck construction were conducted at the University of Missouri-Rolla. Compared with the roof assemblies tested in July 1983, the samples tested in the second phase of the program were fabricated in a different manner, and a different arrangement of the insulation boards and fasteners was used.

This report contains a description of the test setup and procedures used for the tests conducted in December 1983 and presents the results obtained. Section II deals with the details of the two uplift pressure tests, and a conclusion is presented in Section III.

II. UPLIFT PRESSURE TESTS OF INSULATED STEEL ROOF DECK ASSEMBLIES

A. Construction of the Roof System

The steel deck used for the tests was a type N2, 22-gage, roof deck manufactured by Mac-Fab Products, Inc. St. Louis, Missouri.

Figure 1 shows the profile and nominal dimensions of the deck.

Two roof systems with different types of insulation board were used. The cross sections of these systems are shown in Figures 2 and 3. The systems were assembled by Rooftex, Inc. in Houston, Texas, and shipped to the Engineering Research Laboratory at the University of Missouri-Rolla for testing. Before the systems were constructed, steel deck was placed on a frame made of four 4 x 3 x 5/16 in. angles with 3/8 in. diameter bolts welded to a 4 in. leg as shown in Figures 4 and 5. After the deck was welded to the frame at every rib at both ends of the deck, insulation boards or gypsum boards were fastened to the deck. Two different arrangements of roofgrip fasteners were used. As shown in Figure 6(a), eight fasteners were used for each 3 x 4 ft board, i.e., a total of 52 fasteners for the fiberglass insulated built-up roof deck system. For the gypsum board built-up roof deck system, a total of 40 fasteners were used for the 6 x 12 ft assembly as shown in Figure 6(b).

The measured thicknesses of the steel decks for the two systems are given in Table 1.

B. Test Setup

The uplift pressure tests used in this program were similar to the standard test conducted previously by Factory Mutual Research Corporation.²

The apparatus used for the tests consisted of a test frame (12 ft long, 6 ft wide, and 4 in. deep), an air compressor, a water-filled manometer, and a data acquisition system monitor as shown in Figures 7 and 8. The water-filled manometer was used to verify the pressure readings obtained from the data acquisition system monitor.

In the test frame, a 1-1/2 in. diameter hole was used on one 6 ft side for an air supply inlet. A 1/2 in. diameter hole on the same side served as a connection to the data acquisition system monitor and the water-filled manometer.

Before placing the roof assembly on top of the test frame, a rubber gasket was placed on the top flange of the channel sections around the perimeter of the frame to minimize any air leakage.

When the roof assembly was ready for testing, it was placed on top of the test frame: Boards measuring 7/8 x 2-1/4 in. were placed around the perimeter of the assembly. They were followed by 4 x 3 in. angles, which were attached to the roof assembly with washers and nuts as shown in Figures 9 and 10. Five C-Clamps were then securely attached along each 12 ft edge and three along each 6 ft edge (Figure 8).

C. Test Procedure

During the tests, air pressure was supplied with an air compressor. Pressure readings were obtained from a data acquisition system monitor. In addition to the pressure readings, manometer readings were also recorded for the purpose of verification.

Compressed air was introduced beneath the assembly in accordance with the following increments:

<u>Time (Min.)</u>	<u>Pressure (psf)</u>
0:00 to 1:00	30
1:00 to 2:00	45
2:00 to 3:00	60
3:00 to 4:00	75
4:00 to 5:00	90
5:00 to 6:00	105
6:00 to 7:00	120
7:00 to 8:00	135
8:00 to 9:00	150

The pressure was increased in units of 15 psf. After the pressure reached a specified value, it was held for one minute. The pressure was continuously increased in units of 15 psf until the roof system failed.

Before performing the formal tests, a gypsum board built-up roof deck system was pilot tested for the purpose of checking the equipment and establishing the procedure.

D. Test Results

Two formal uplift pressure tests were conducted on December 15, 1983. Pressure and manometer readings were recorded according to the pressure increments described in Item C. All the test data are presented in Table 2. The pressures computed from the manometer readings are also given in this table for each test. The minor discrepancies between the air pressure obtained directly from the monitor and the value computed from the manometer readings were due to the fact that it was difficult to read the precise values on the manometer.

During the test, the roof system was carefully observed for the presence of bowing on the top of the assembly. It was noted that for the fiberglass insulated built-up roof deck system, the assembly began to fail at the pressure of 103 psf. This was evidenced by hearing a

noise and the appearance of a large amount of bowing. However, the system did not fail completely until the pressure reached at 162 psf. After the test was completed, the built-up roof was dismantled at the locations shown in Figures 12(a) and 13(a) for the purpose of observing the delamination of the insulation board. In addition, the failure mode of steel roof deck (Figure 14) was also examined. Examination of the assembly indicated that the system finally failed as a result of the flexure of the steel deck, because none of the fasteners had been pulled through the insulation board. Only six of the Roofgrip fasteners were tilted at the failure load, as shown in Figure 11(a).

For the gypsum board built-up roof deck system, the complete failure of the system occurred at a pressure of 150 psf. During the test, noises were heard at different pressures as indicated in Table 2b. After the test was completed, the built-up roof was dismantled at the locations shown in Figures 12(b) and 13(b) for the purpose of observing the delamination of the gypsum board. In addition, the failure mode of the steel roof deck (Figure 15) was also examined. Examination of the assembly indicated that the system finally failed as a result of the flexure of the steel deck. It was noted that 12 of the roofgrip fasteners had been pulled through the deck (Figure 11(b)).

In both systems, the elastomeric roof membrane was found to be able to sustain the pressures recorded in Table 2.

III. CONCLUSION

Two formal uplift pressure tests of insulated steel deck roof systems were conducted at the University of Missouri-Rolla in December 1983.

Based on the results obtained from the two uplift pressure tests of insulated steel roof deck assemblies, it is concluded that both roof deck systems (fiberglass insulated built-up roof deck system and gypsum board built-up roof deck system) are adequate for a Class I-90 rating.

IV. ACKNOWLEDGMENTS

The project was conducted in the Engineering Research Laboratory of the University of Missouri-Rolla under the sponsorship of Rooftex, Inc., Houston, Texas.

The financial assistance granted by the sponsor is gratefully acknowledged. The roof assemblies used for the uplift pressure tests were constructed by Rooftex, Inc., Houston, Texas.

Appreciation is expressed to Messrs. Eugene Dunn (Factory Mutual Research), Elmo Branson (Mac-Fab Products, Inc.), and Yaromir Steiner, Andre Desumeur, Yves Ponchel, and Claude Boethas (all of Rooftex Inc.) for their advice and technical guidance. Messrs. Eugene Dunn, Elmo Branson, Yves Ponchel, and Claude Boethas witnessed the uplift pressure tests of the roof systems.

Thanks are extended to Messrs. K. Haas, J.A. Tucker, M.E. Light, Ross Haselhorst, C. Santaputra, and M.B. Parks for their help in preparing the test equipment and in conducting the tests.

Special thanks are extended to Mrs. He'lene MacElroy for her assistance and Mrs. DeAnne Larson for typing this report. Appreciation is also expressed to Mr. John W. Koenig for his editorial review and suggestions.

V. REFERENCES

1. Sucharit, S., Pan, L.C., and Yu, W. W., "Testing of Steel Roof Deck Construction," First Progress Report, University of Missouri-Rolla, August 1983.
2. "Uplift Pressure Test Standard for Class I Insulated Steel Roof Deck Construction", Appendix B, Factory Mutual Research Corporation, Revised August 5, 1977.

Table 1

Measured Thicknesses of Steel Decks with
Galvanized Finish Coating Class G-90

Roof System	Total Measured Thickness (in.)*		
	1st sheet	2nd sheet	3rd sheet
Fiberglass Insulated Built-up Roof Deck System	0.0310	0.0310	0.0311
Gypsum Board Built-up Roof Deck System	0.0311	0.0311	0.0310

* Black Steel Thickness Subtract 0.002 in.

Table 2a

Uplift Pressure Test of Fiberglass Insulated
Built-up Roof Deck System

Pressure Reading Obtained from Monitor (psf)	Manometer Reading (in.)			Pressure Computed from Manometer Reading (psf)	Remarks
	Left Column (in.)	Right Column (in.)	Head (in.)		
0	14.05	14.05	0	0	Noises were heard for the following Pressures: 103 psf 134 psf 135 psf 138 psf
30	11.15	16.95	5.80	30.16	
45	9.70	18.40	8.70	45.24	
60	8.30	19.80	11.50	59.8	
75	6.80	21.25	14.45	75.14	
90	5.40	22.70	17.30	89.96	
105	4.00	24.10	20.10	104.52	
120	2.50	25.60	23.10	120.12	
135	1.20	26.90	25.70	133.64	
150	*	28.40	*	*	
162**	*	*	*	*	

* Beyond the range of manometer

** Maximum pressure at failure

Table 2b

Uplift Pressure Test of Gypsum Board

Built-up Roof Deck System

Pressure Reading Obtained from Monitor (psf)	Manometer Reading (in.)			Pressure Computed from Manometer Reading (psf)	Remarks
	Left Column (in.)	Right Column (in.)	Head (in.)		
0	14.05	14.05	0	0	Noises were heard for the following Pressures: 72.5 psf 89 psf 99 psf 102 psf 105 psf 128 psf 135 psf 143 psf 145 psf 149 psf
30	11.15	16.95	5.80	30.16	
45	9.80	18.30	8.50	44.20	
60	8.35	19.75	11.40	59.28	
75	6.95	21.10	14.15	73.58	
90	5.45	22.55	17.10	88.92	
105	4.10	24.00	19.90	103.48	
120	2.65	25.35	22.70	118.04	
135	1.30	26.80	25.50	132.60	
150**	*	28.25	*	*	

* Beyond the range of Manometer
 ** Sustain 20 seconds

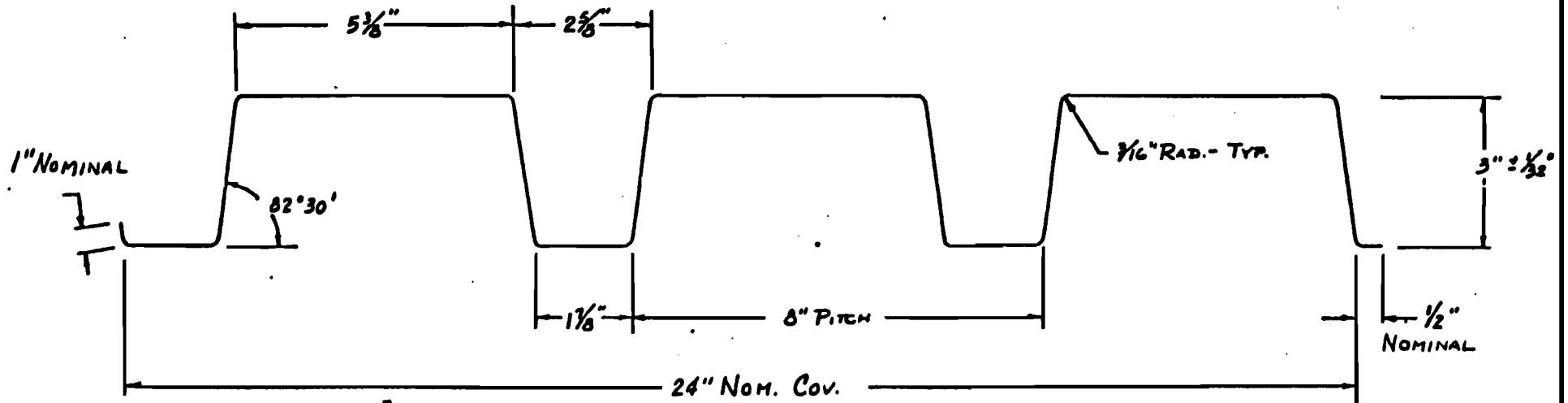

MAC FAB			
700 SOUTH SPRING AVE., ST. LOUIS, MO. 63110			
P. O. BOX 15193, ST. LOUIS, MO. 63110			
DRAWN: SLM		FILE NO.	SHEET NO.
DATE: 3-15-80		TYPE N2 DECK	FAB-2
APPROVED:		FLAT LAP	or

DATE	BY	APP.	REVISIONS
12/28/83	EDE		DIMENSIONAL CHANGE

Fig. 1 Type N2, 22 ga. 3 in. Deep Steel Deck

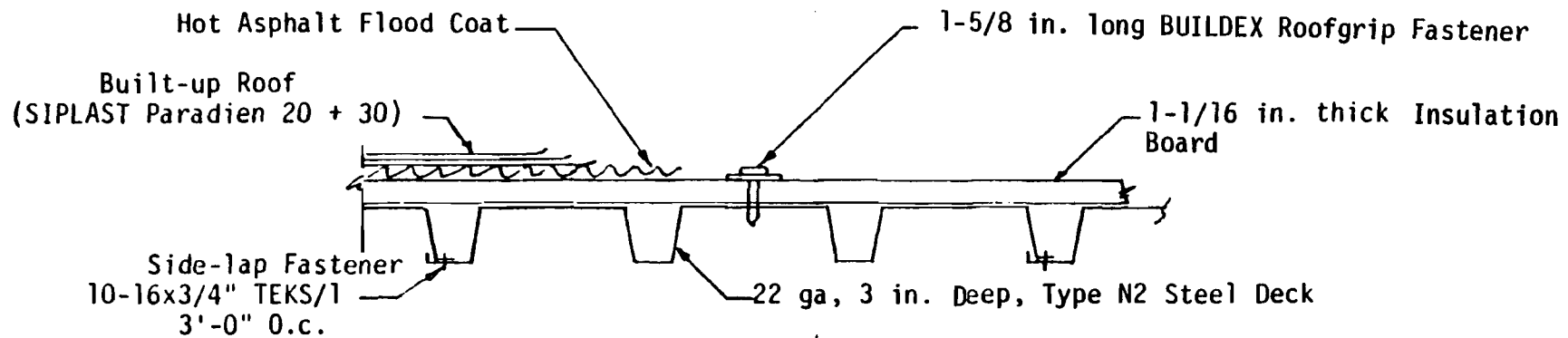

-11-

Fig. 2 Fiberglass Insulated Built-up Roof Deck System

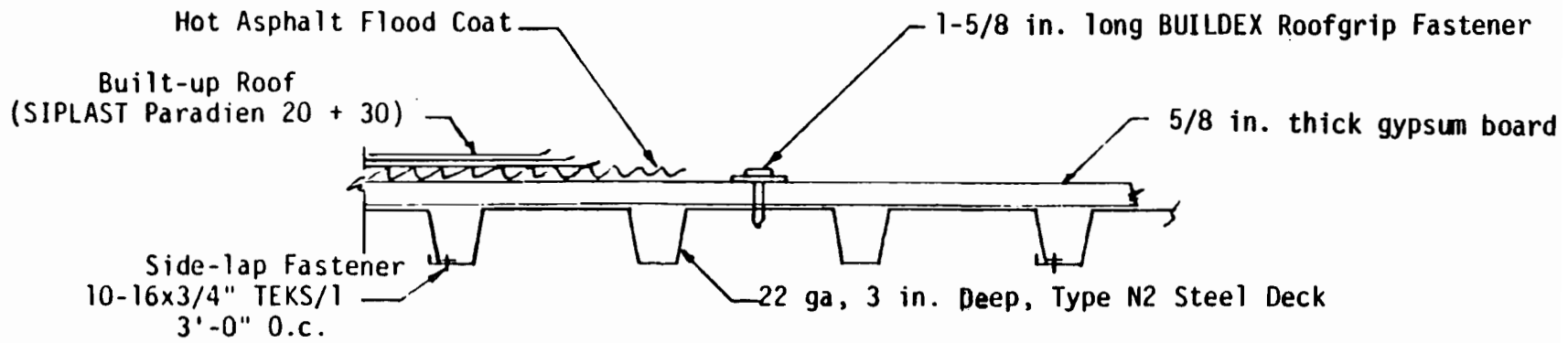
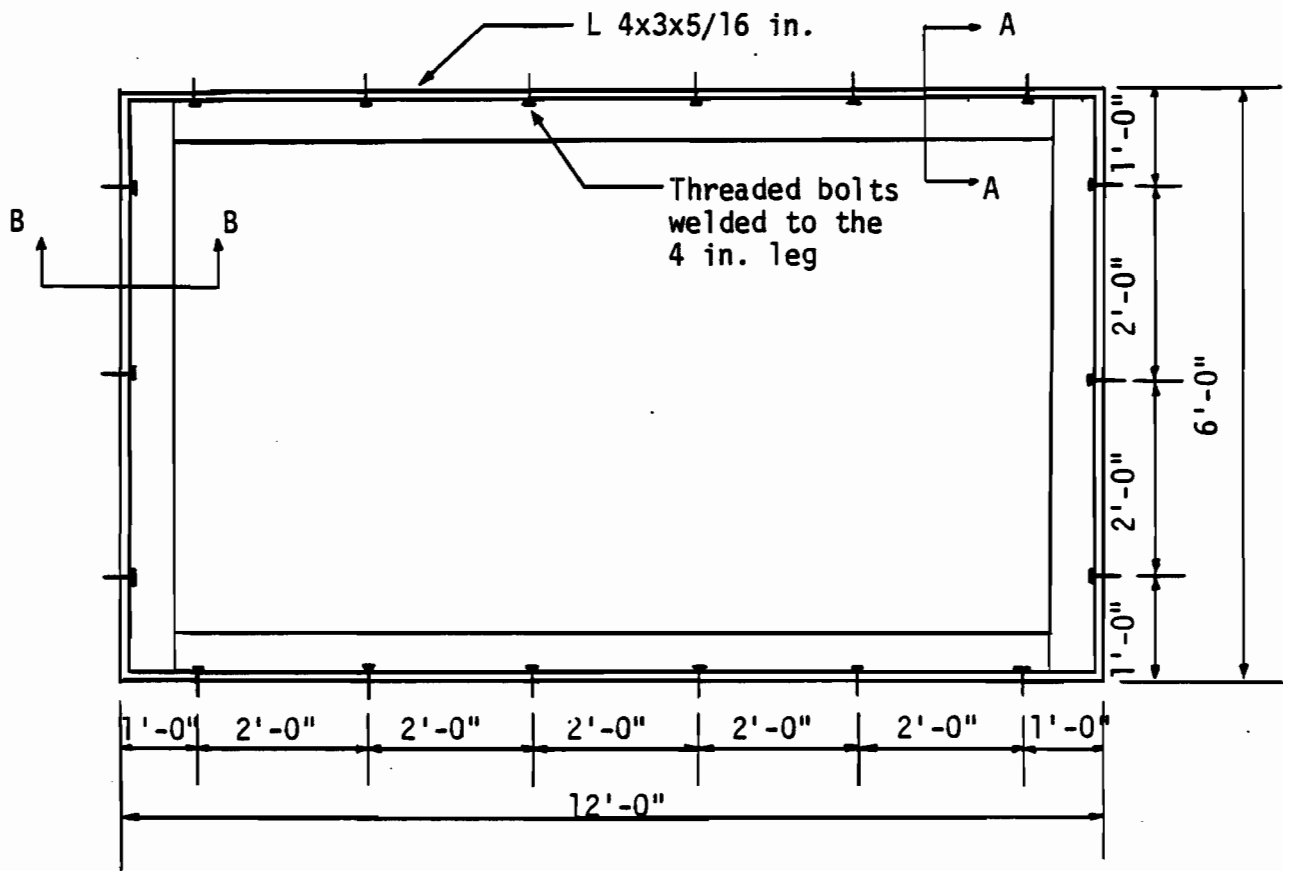
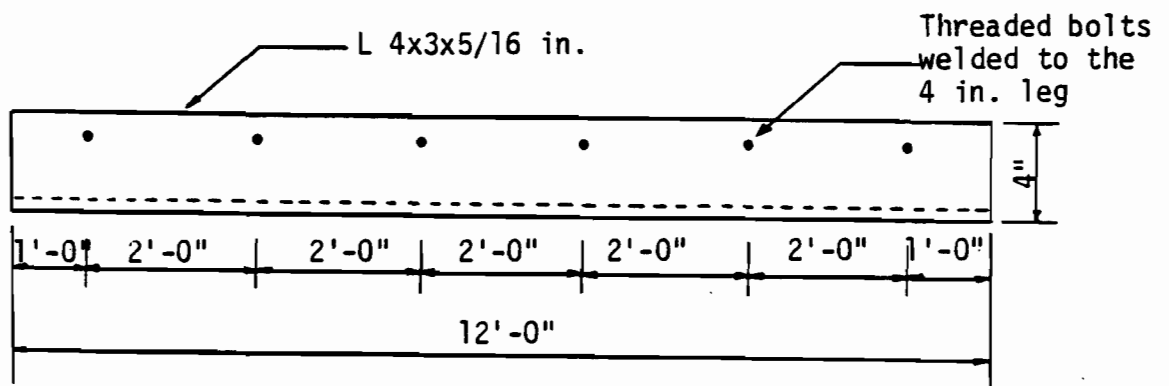

Fig. 3 Gypsum Board Built-up Roof Deck System



Top View



Side View

Fig. 4 Angle Frame Used for the Construction of Roof Systems (See Fig. 5 for Sections A-A and B-B)

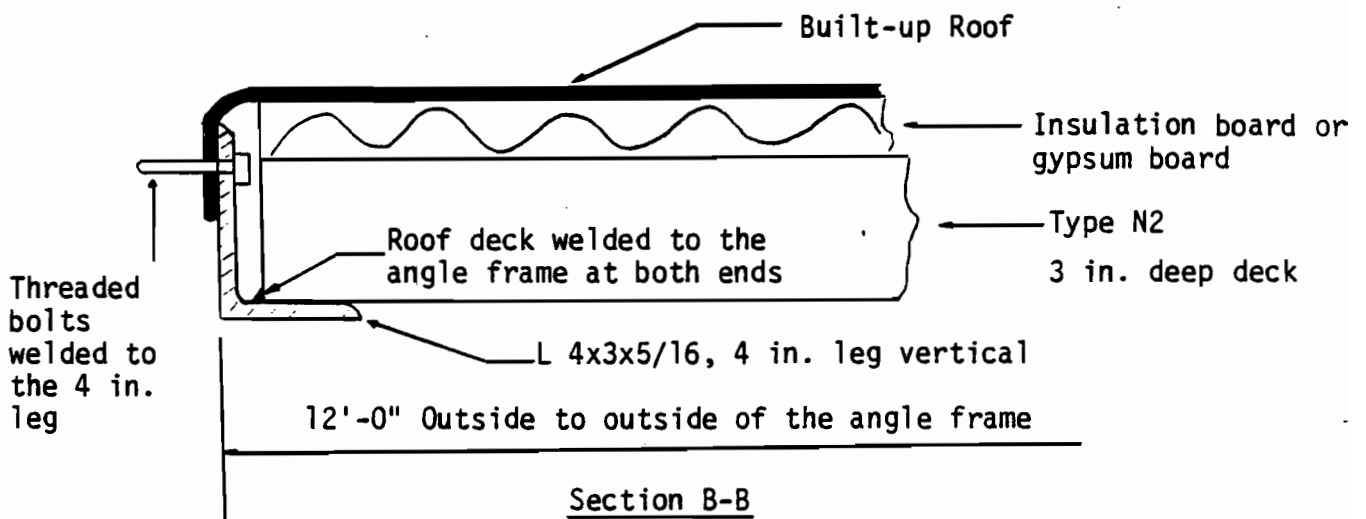
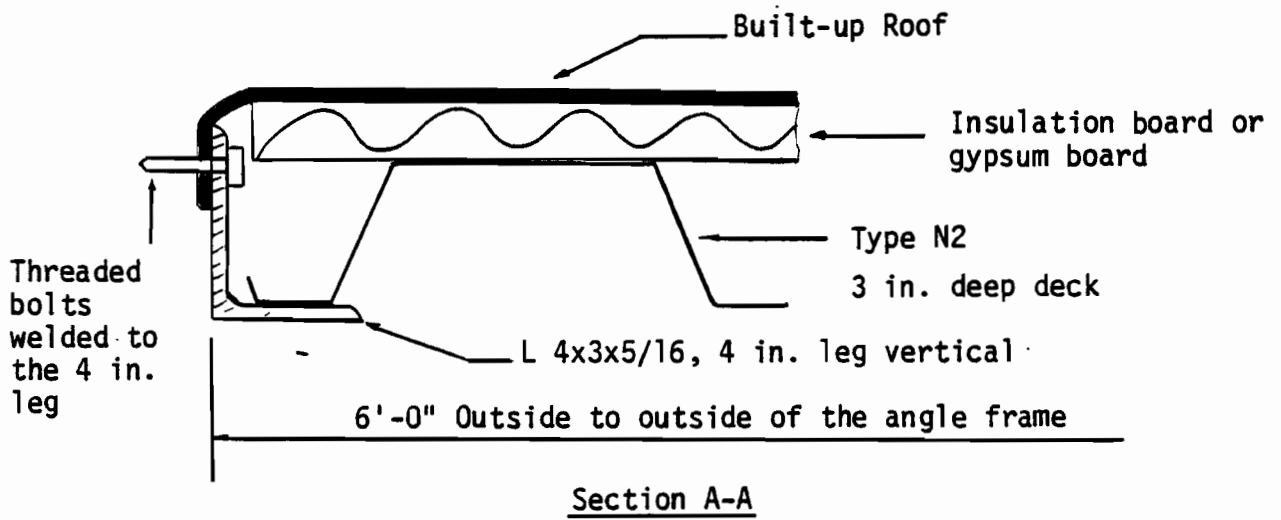
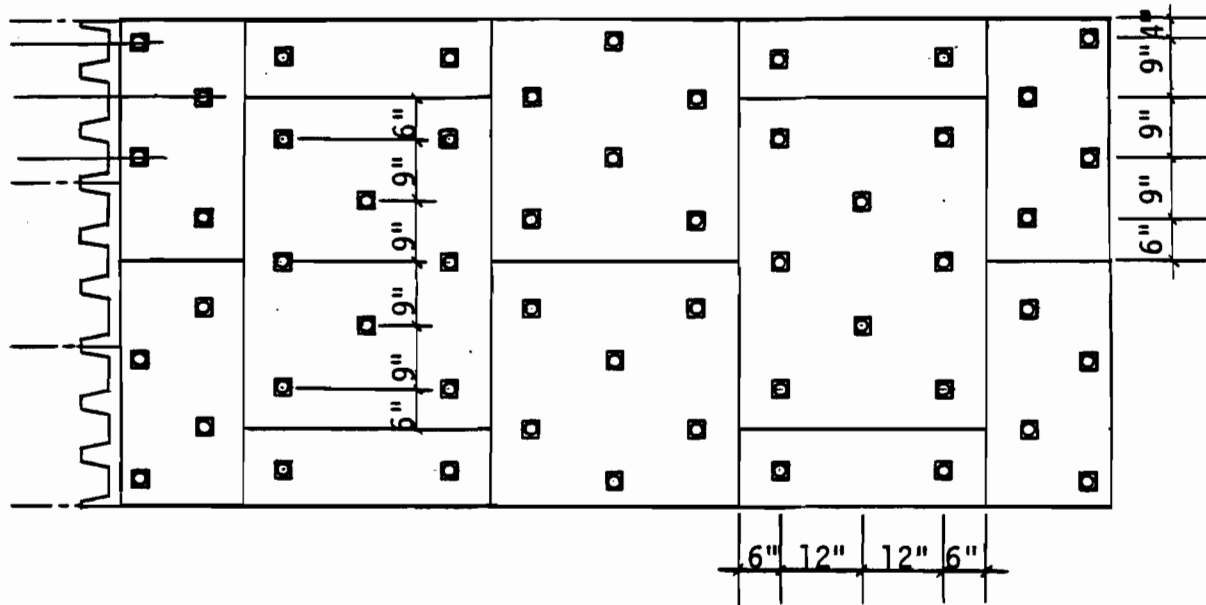
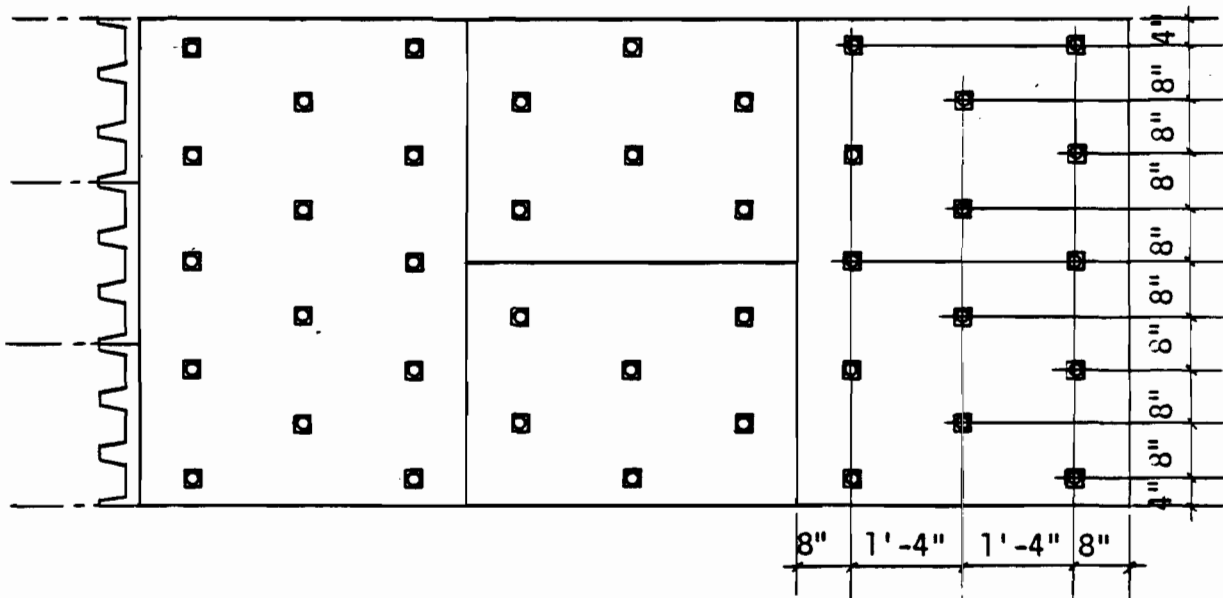

Fig. 5 Cross Sections of Roof Systems



(a) Fiberglass Insulated Built-up Roof Deck System



(b) Gypsum Board Built-up Roof Deck System

Fig. 6 Arrangements of Roofgrip Fasteners

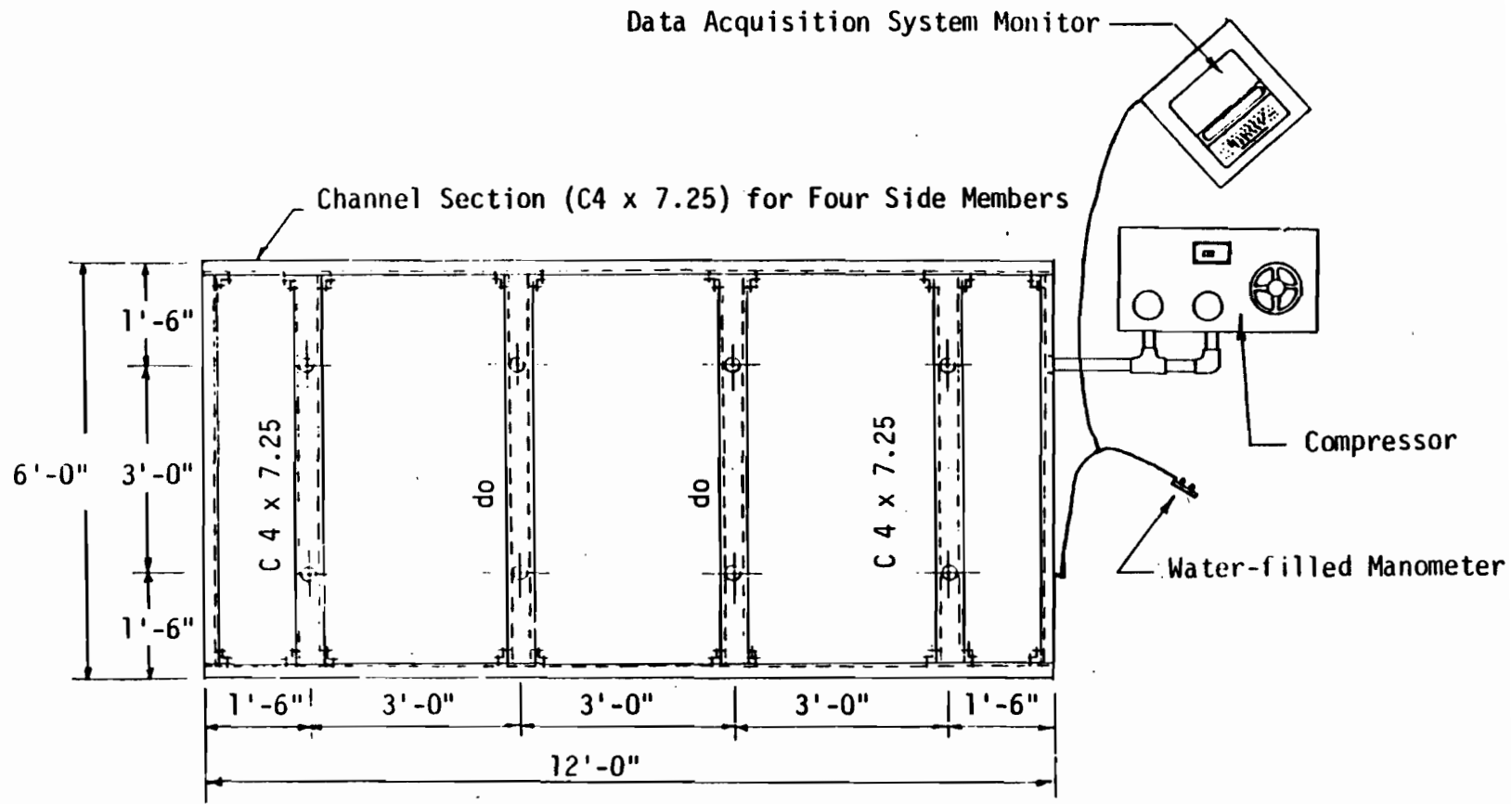

Fig. 7 Test Frame and Apparatus Used for the Uplift Pressure Test

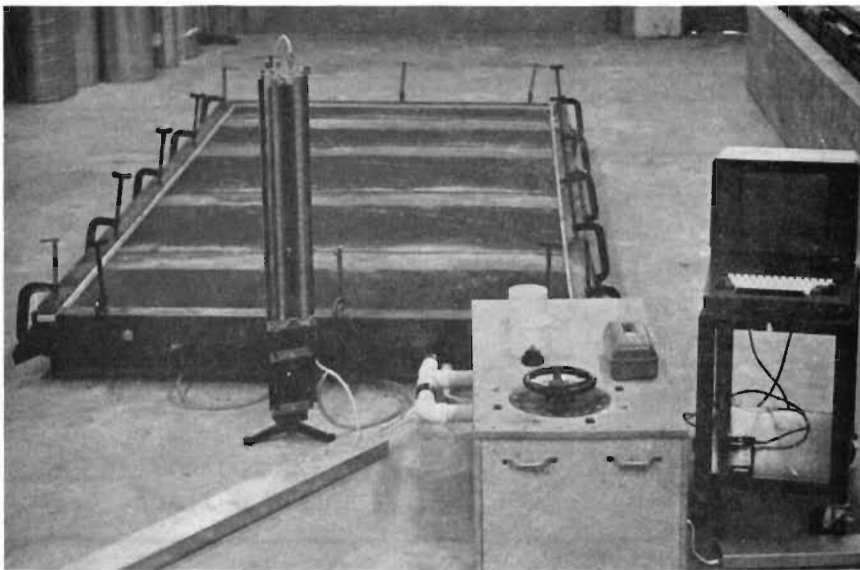
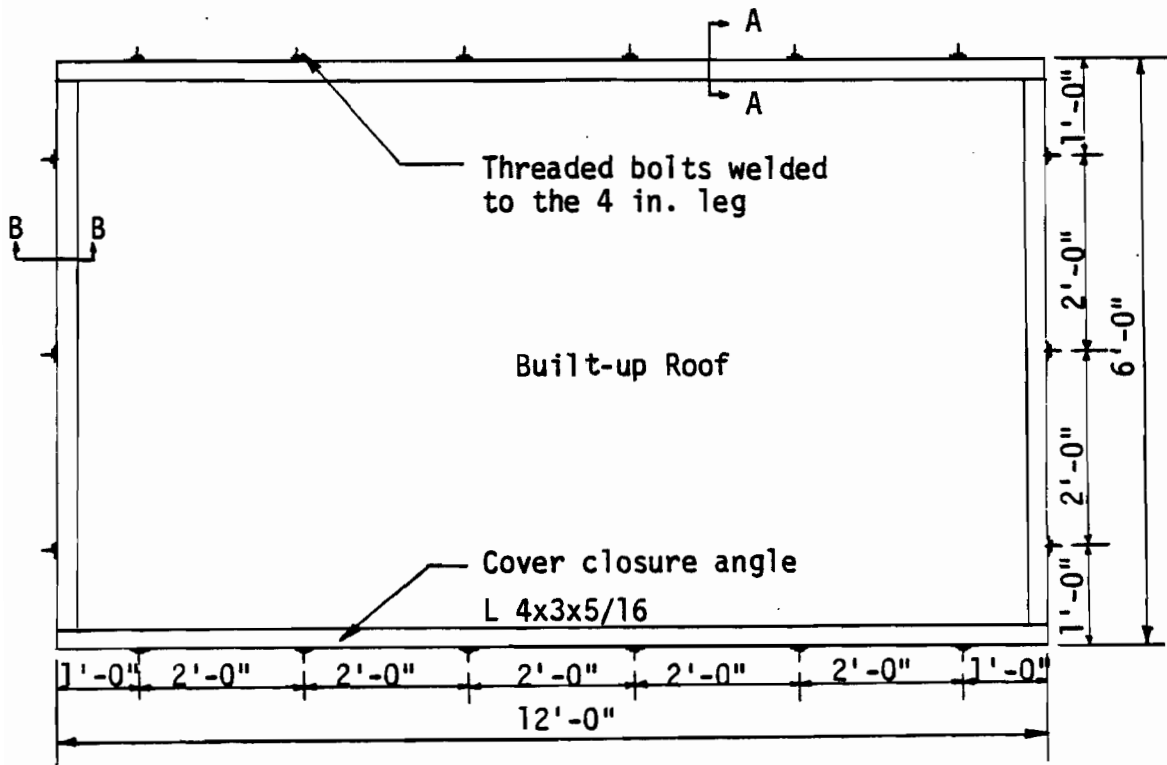
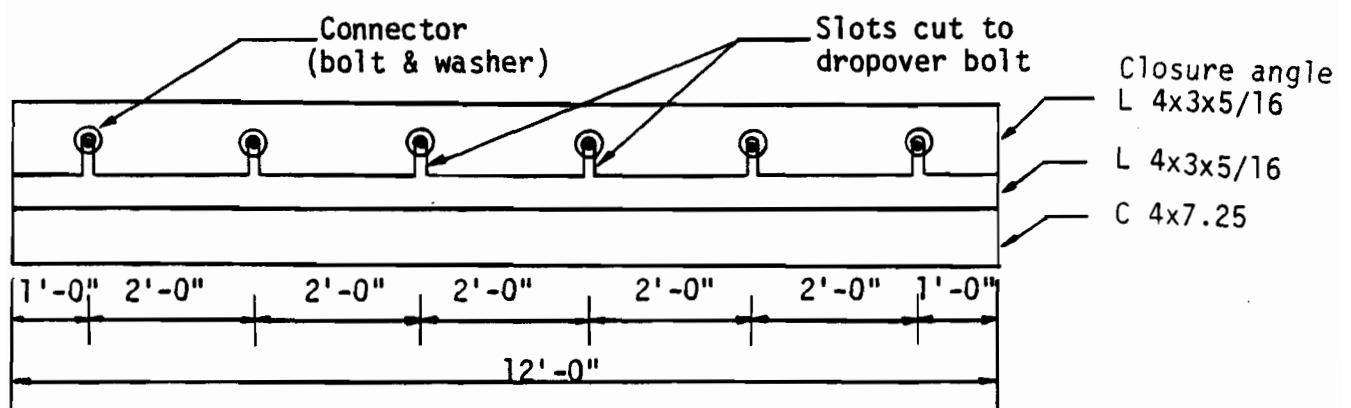

Fig. 8 Photograph of Uplift Pressure Test Setup



Top View



Side View

Fig. 9 Uplift Pressure Test Setup (See Fig. 10 for Sections A-A and B-B)

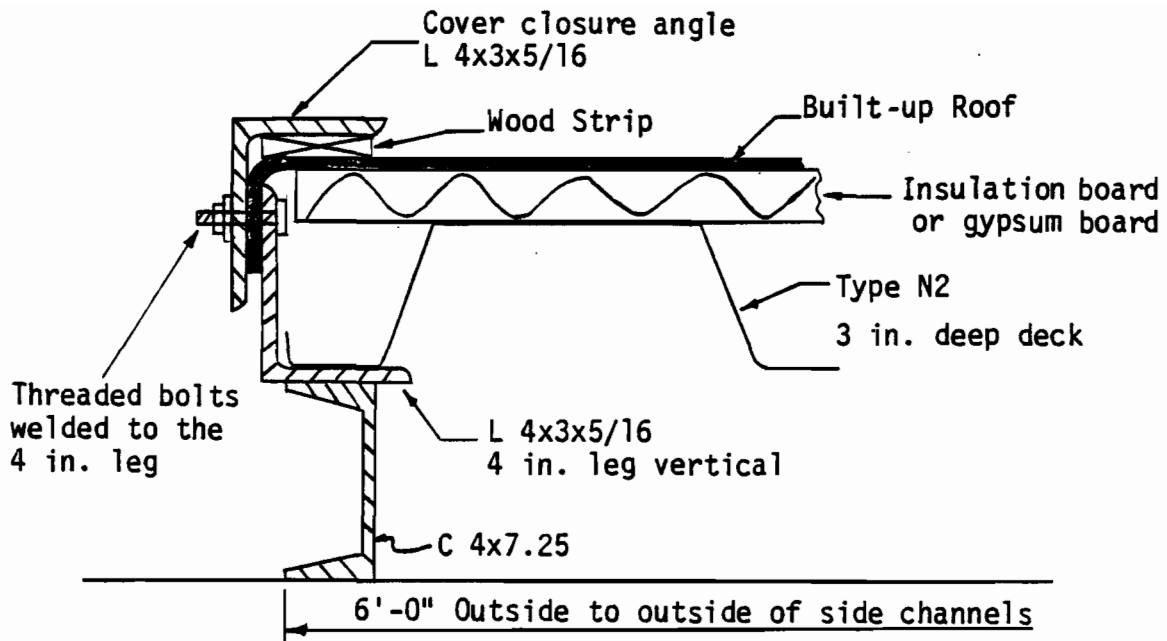

Section A-A

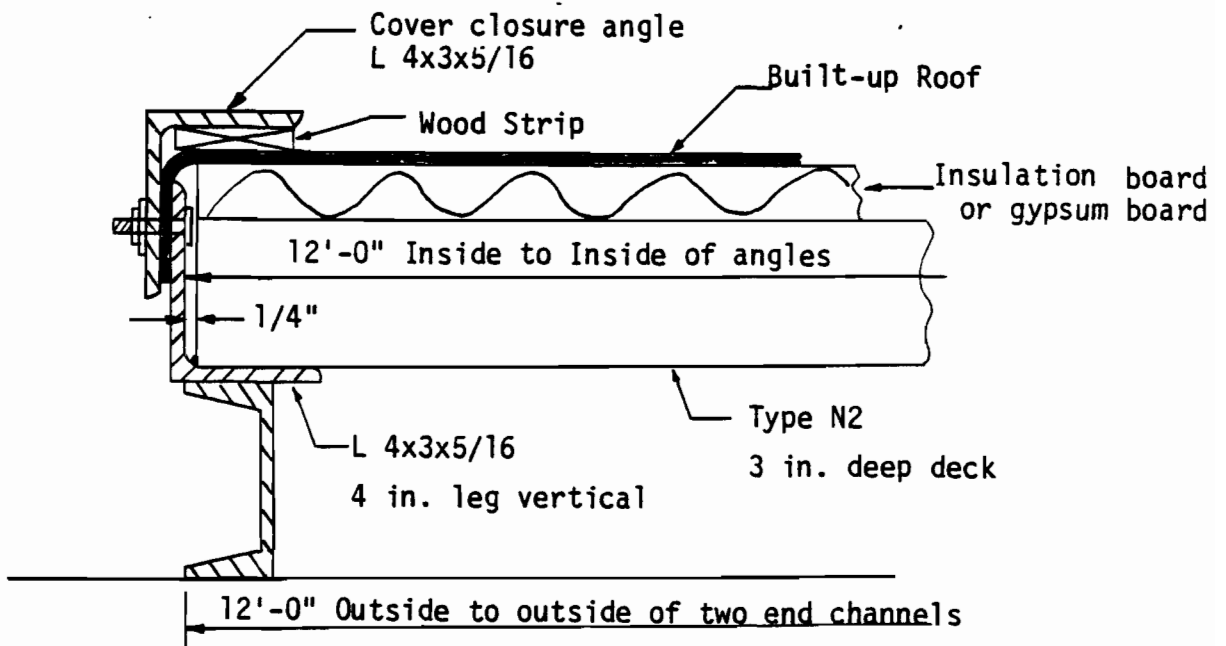

Section B-B

Fig. 10 Cross Sections of Uplift Pressure Test Setup

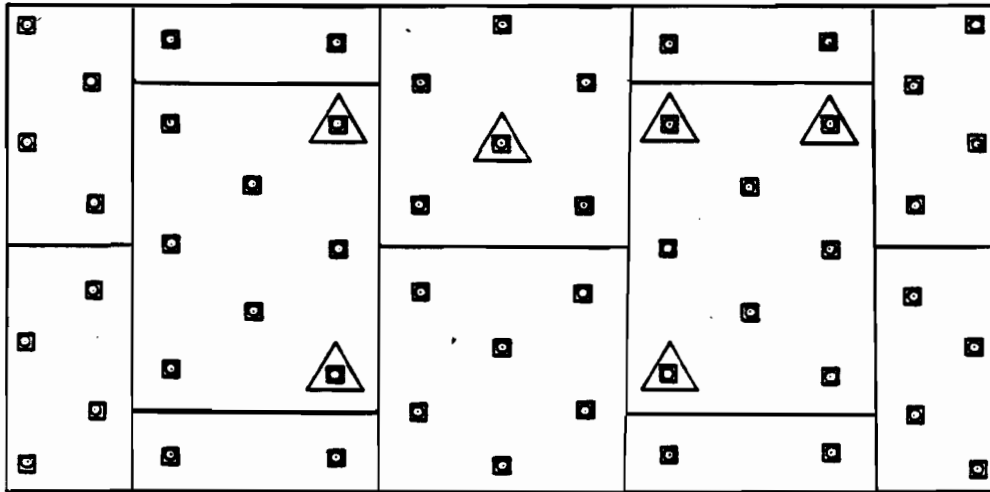

Note: Symbol "Δ" indicates tilted roofgrip fasteners

(a) Fiberglass Insulated Built-up Roof Deck System

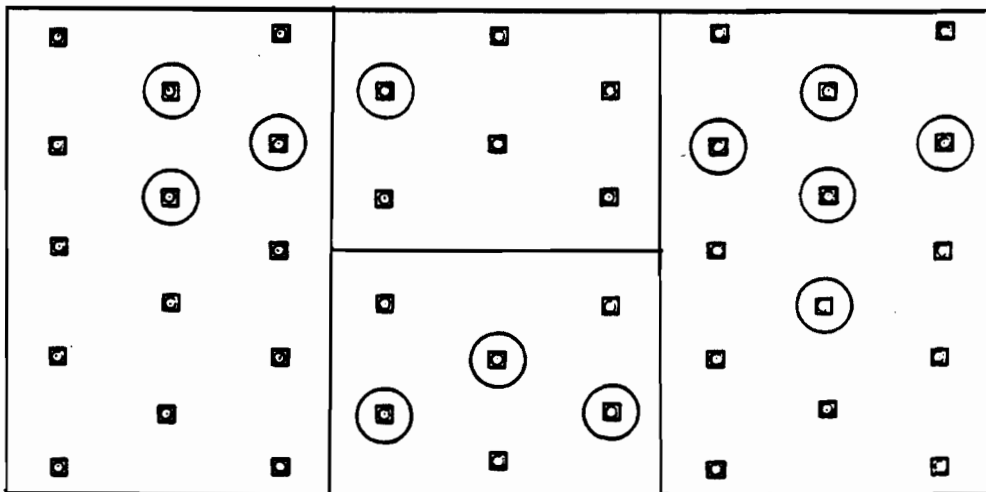

Note: Symbol "O" indicates the locations where fasteners pulled through

(b) Gypsum Board Built-up Roof Deck System

Fig. 11 Locations of Fasteners Pulled Through and Tilted

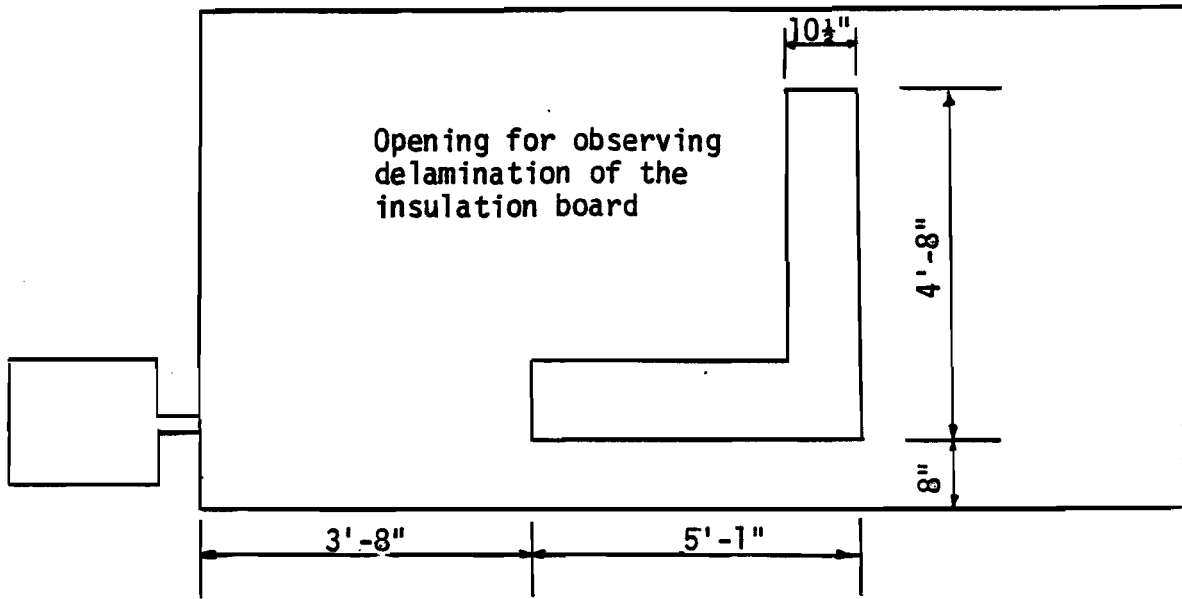

(a) Fiberglass Insulated Built-up Roof Deck System

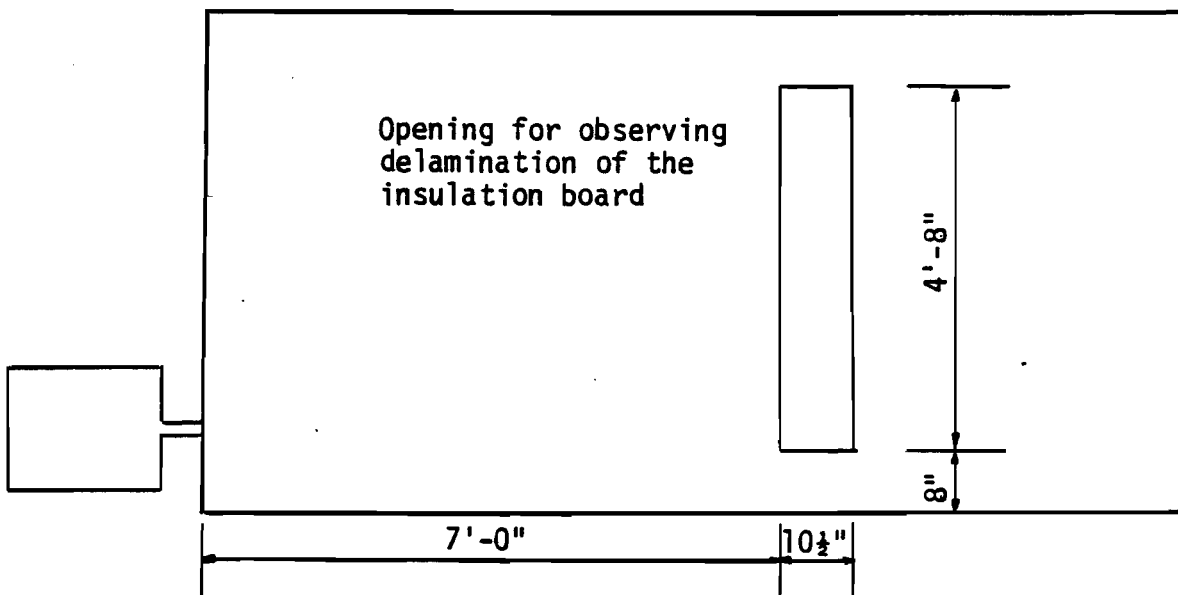

(b) Gypsum Board Built-up Roof Deck System

Fig. 12 Locations of Dismantled Roof

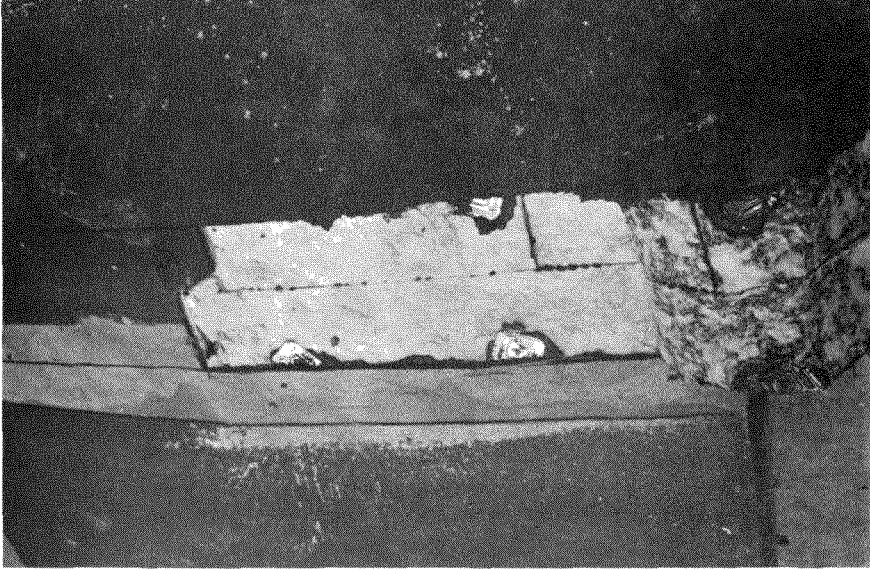

(b) Gypsum Board Built-up
Roof Deck System



(a) Fiberglass Insulated Built-up Roof Deck System

Fig. 13 Top View of Dismantled Roof Systems

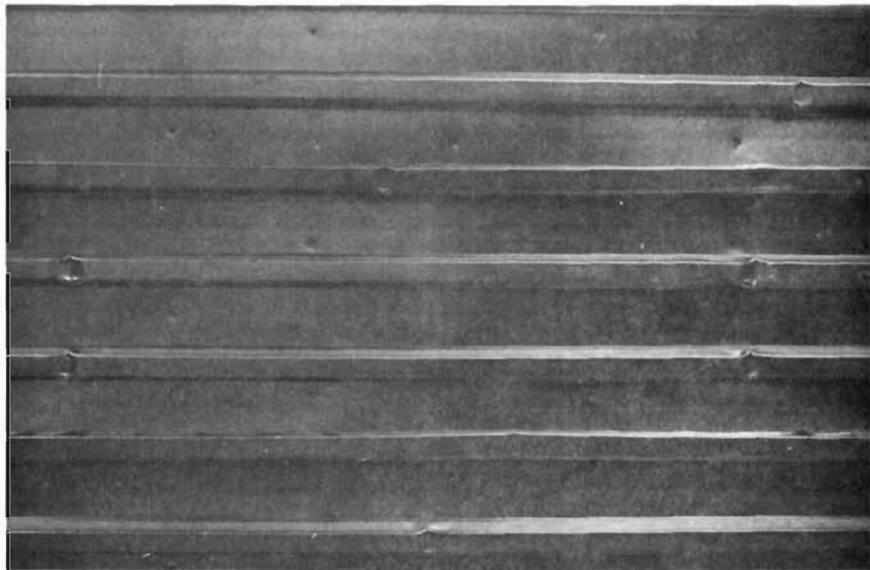
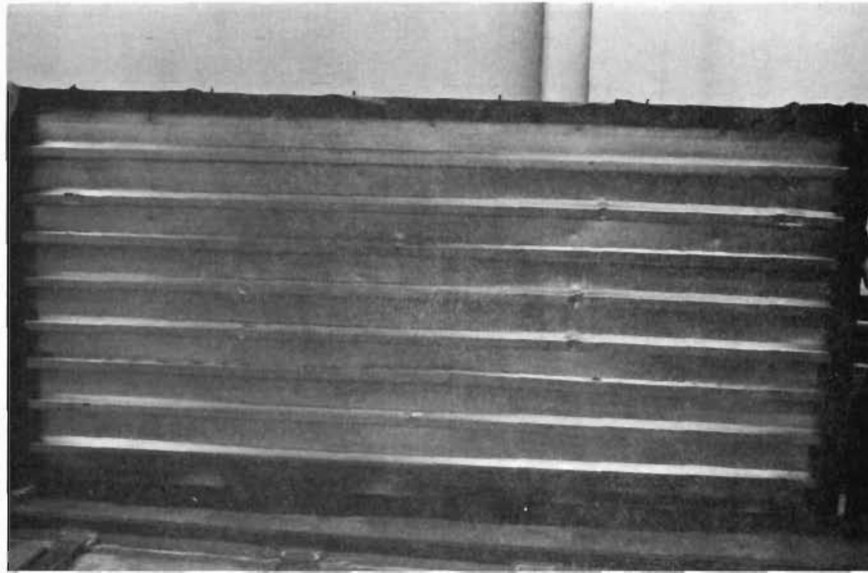

Fig. 14 Flexural Failure of Steel Deck for Fiberglass Insulated Built-up Roof Deck System

-24-

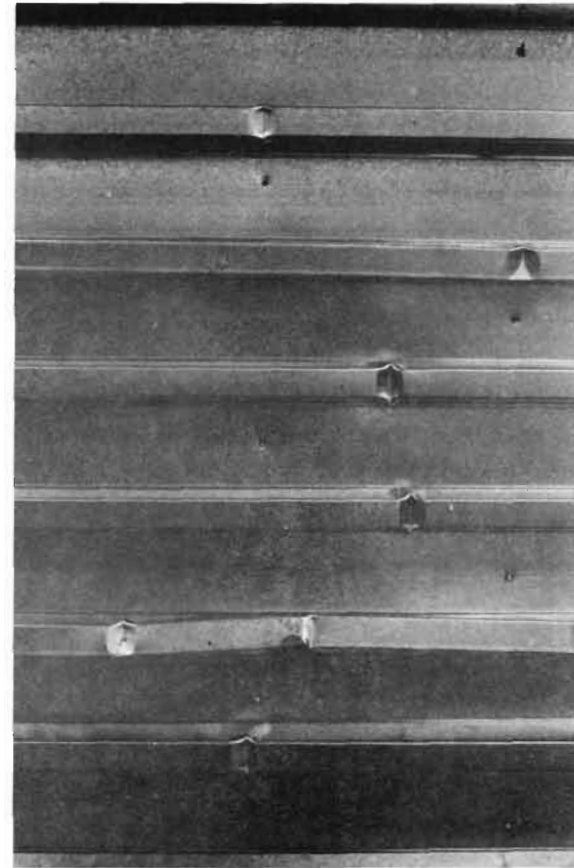
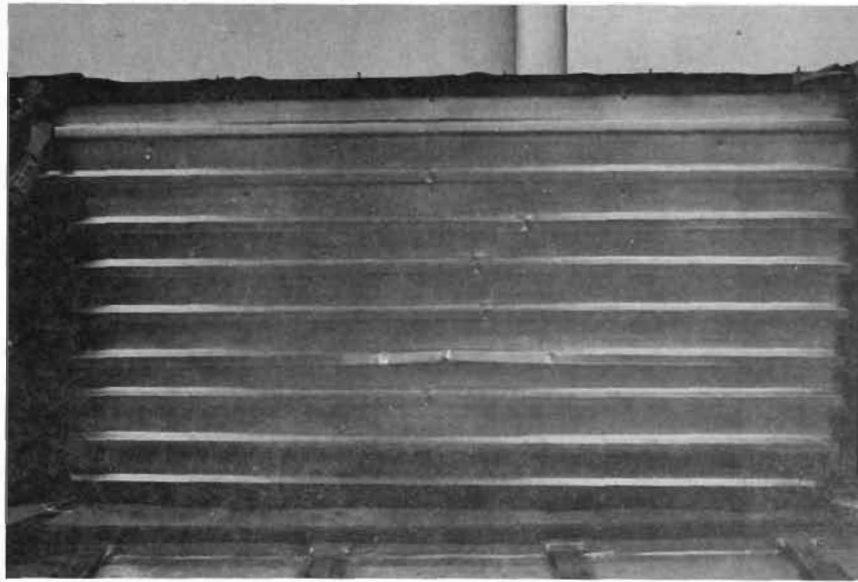

Fig. 15 Flexural Failure of Steel Deck for Gypsum Board Built-up
Roof Deck System