

01 Aug 2010

## Supplement No. 2 to the North American Specification for the Design of Cold-Formed Steel Structural Members, 2007 Edition

American Iron and Steel Institute

Follow this and additional works at: <https://scholarsmine.mst.edu/ccfss-aisi-spec>



Part of the [Structural Engineering Commons](#)

---

### Recommended Citation

American Iron and Steel Institute, "Supplement No. 2 to the North American Specification for the Design of Cold-Formed Steel Structural Members, 2007 Edition" (2010). *AISI-Specifications for the Design of Cold-Formed Steel Structural Members*. 168.

<https://scholarsmine.mst.edu/ccfss-aisi-spec/168>

This Technical Report is brought to you for free and open access by Scholars' Mine. It has been accepted for inclusion in AISI-Specifications for the Design of Cold-Formed Steel Structural Members by an authorized administrator of Scholars' Mine. This work is protected by U. S. Copyright Law. Unauthorized use including reproduction for redistribution requires the permission of the copyright holder. For more information, please contact [scholarsmine@mst.edu](mailto:scholarsmine@mst.edu).



S100-07/S2-10



## **AISI** STANDARD

**Supplement No. 2 to the North  
American Specification for the  
Design of Cold-Formed Steel  
Structural Members, 2007 Edition**

FEBRUARY 2010

Approved in Canada by the  
Canadian Standards Association  
CSA S136-07/S1-10

Endorsed in Mexico by CANACERO



The material contained herein has been developed by a joint effort of the American Iron and Steel Institute Committee on Specifications, the Canadian Standards Association Technical Committee on Cold Formed Steel Structural Members (S136), and Camara Nacional de la Industria del Hierro y del Acero (CANACERO) in Mexico. The organizations and the Committees have made a diligent effort to present accurate, reliable, and useful information on cold-formed steel design. The Committees acknowledge and are grateful for the contributions of the numerous researchers, engineers, and others who have contributed to the body of knowledge on the subject. Specific references are included in the *Supplement to the Commentary on the Specification*.

With anticipated improvements in understanding of the behavior of cold-formed steel and the continuing development of new technology, this material may eventually become dated. It is anticipated that future editions of this specification will update this material as new information becomes available, but this cannot be guaranteed.

The materials set forth herein are for general information only. They are not a substitute for competent professional advice. Application of this information to a specific project should be reviewed by a registered professional engineer. Indeed, in most jurisdictions, such review is required by law. Anyone making use of the information set forth herein does so at their own risk and assumes any and all resulting liability arising therefrom.

1st Publishing – August, 2010

Produced by American Iron and Steel Institute

Copyright American Iron and Steel Institute and Canadian Standards Association 2010

## PREFACE

This Supplement No. 2 to the *North American Specification for the Design of Cold-Formed Steel Structural Members*, 2007 edition, includes the following updates and improvements:

- Included all the changes and updates provided in Supplement No. 1 to the *North American Specification for the Design of Cold-Formed Steel Structural Members*, 2007 Edition.
- Added new Section B2.5, Uniformly Compressed Elements Restrained by Intermittent Connections.
- Unified country specific provisions, C2, Tension Members, and the section has been moved from Appendices A and B to the main body of the *Specification*.
- Moved the simplified provisions for determine distortional buckling strength of C- or Z-section beams and columns to the *Commentary*.
- Revised Sections D1.1, D1.2, D3 and D3.2 to clarify certain terminologies.
- Consolidated whole Chapter E, Connections and Joints. Additionally, flare groove weld provisions were revised; and the interaction check of combined shear and tension of arc spot weld was added.
- Expanded the geometric and material limitations of pre-qualified columns and beams for using the safety and resistance factors defined in Sections 1.2.1 and 1.2.2, respectively.

American Iron and Steel Institute  
Canadian Standards Association  
Camara Nacional de la Industria del Hierro y del Acero  
February 2010

**This Page is Intentionally Left Blank.**

## North American Specification Committee

### AISI

R. L. Brockenbrough  
H. H. Chen  
J. N. Nunnery

### CSA

R. M. Schuster, *Chairman*  
S. R. Fox, *Secretary*  
T. W. J. Trestain

## AISI Committee on Specifications for the Design of Cold-Formed Steel Structural Members and its Subcommittees

R. L. Brockenbrough, <i>Chairman</i>	R. B. Haws, <i>Vice-Chairman</i>	H. H. Chen, <i>Secretary</i>	D. Allen
R. Bjorhovde	C. J. Carter	J. K. Crews	D. A. Cuoco
W. S. Easterling	D. S. Ellifritt	J. M. Fisher	S. R. Fox
P. S. Green	W. B. Hall	G. J. Hancock	A. J. Harrold
D. L. Johnson	R. A. LaBoube	J. A. Mattingly	W. McRoy
J. A. Moses	J.R. U. Mujagic	T. M. Murray	J. N. Nunnery
T. B. Pekoz	N. A. Rahman	G. Ralph	V. E. Sagan
T. Samiappan	B. W. Schafer	K. Schroeder	R. M. Schuster
P. A. Seaburg	W. L. Shoemaker	T. Sputo	T. W. J. Trestain
D. P. Watson			

### Subcommittee 3 - Connections

P. S. Green, <i>Chairman</i>	R. Bjorhovde	L. R. Daudet	W. S. Easterling
D. S. Ellifritt	N. Eshwar	D. Fulton	W. Gould
W. B. Hall	G. J. Hancock	A. J. Harrold	R. B. Haws
D. Johnson	D. L. Johnson	W. E. Kile	R. A. LaBoube
J. A. Mattingly	A. Merchant	C. Moen	J. R. U. Mujagic
T. M. Murray	J. N. Nunnery	T. B. Pekoz	N. A. Rahman
V. E. Sagan	T. Samiappan	R. M. Schuster	W. L. Shoemaker
T. Sputo	C. Yu		

### Subcommittee 4 – Light Frame Steel Construction

D. Allen, <i>Chairman</i>	L. R. Daudet	S. R. Fox	P. S. Green
R. A. LaBoube	J. P. Matsen	T. H. Miller	T. B. Pekoz
N. A. Rahman	V. E. Sagan	H. Salim	B. W. Schafer
K. Schroeder	T. Sputo	T. W. J. Trestain	J. Wellinghoff
C. Yu	R. Zadeh		

### Subcommittee 6 – Test Procedures

T. Sputo, <i>Chairman</i>	T. Anderson	L. R. Daudet	D. S. Ellifritt
S. R. Fox	D. Fulton	P. S. Green	W. B. Hall
R. C. Kaehler	W. E. Kile	R. A. LaBoube	T. J. Lawson
J. A. Mattingly	F. Morello	T. M. Murray	T. B. Pekoz
N. A. Rahman	C. Ramseyer	T. Samiappan	R. M. Schuster

**Subcommittee 10 – Element Behaviors**

D. L. Johnson, <i>Chairman</i>	L. R. Daudet	N. Eshwar	R. S. Glauz
G. J. Hancock	A. J. Harrold	R. C. Kaehler	W. E. Kile
J. A. Mattingly	T. H. Miller	C. Moen	F. Morello
T. M. Murray	J. N. Nunnery	T. B. Pekoz	T. Samiappan
B. W. Schafer	W. L. Shoemaker	T. W. J. Trestain	C. Yu

**Subcommittee 21 – Strategic Planning and Research**

R. B. Haws, <i>Chairman</i>	D. Allen	S. J. Bianculli	R. Bjorhovde
R. L. Brockenbrough	J. K. Crews	J. M. Fisher	S. R. Fox
P. S. Green	A. J. Harrold	D. L. Johnson	R. A. LaBoube
J. A. Mattingly	R. M. Schuster	P. A. Seaburg	W. L. Shoemaker
T. Sputo			

**Subcommittee 22 – Compression Members**

J. K. Crews, <i>Chairman</i>	D. Allen	R. Bjorhovde	L. R. Daudet
D. S. Ellifritt	N. Eshwar	P. S. Green	G. J. Hancock
A. J. Harrold	D. L. Johnson	T. H. Miller	C. Moen
J. N. Nunnery	T. B. Pekoz	C. Ramseyer	T. Samiappan
B. W. Schafer	R. M. Schuster	D. R. Sherman	T. Sputo
T. W. J. Trestain			

**Subcommittee 24 – Flexural Members**

A. J. Harrold, <i>Chairman</i>	D. A. Cuoco	L. R. Daudet	D. S. Ellifritt
J. M. Fisher	D. Fulton	P. S. Green	G. J. Hancock
R. B. Haws	D. L. Johnson	W. E. Kile	R. A. LaBoube
T. J. Lawson	J. A. Mattingly	T. H. Miller	T. M. Murray
J. N. Nunnery	T. B. Pekoz	C. Ramseyer	T. Samiappan
B. W. Schafer	K. Schroeder	R. M. Schuster	P. A. Seaburg
J. Sears	M. Seek	W. L. Shoemaker	T. Sputo
T. W. J. Trestain	J. Walsh	D. P. Watson	

**Subcommittee 26 - Design Manual**

P. A. Seaburg, <i>Chairman</i>	D. Allen	R. Bjorhovde	C. J. Carter
J. Crews	D. A. Cuoco	R. S. Glauz	R. B. Haws
D. L. Johnson	R. C. Kaehler	R. A. LaBoube	T. M. Murray
J. N. Nunnery	B. W. Schafer	R. M. Schuster	

**Subcommittee 30 - Education**

R. A. LaBoube, <i>Chairman</i>	D. Allen	R. Bjorhovde	J. K. Crews
W. S. Easterling	P. S. Green	J. A. Mattingly	N. A. Rahman
K. Schroeder	R. M. Schuster	B. W. Schafer	P. A. Seaburg
C. Yu			

**Subcommittee 31 – General Provisions**

J. M. Fisher, <i>Chairman</i>	D. Allen	R. Bjorhovde	C. J. Carter
J. K. Crews	D. A. Cuoco	L. R. Daudet	W. B. Hall
A. J. Harrold	D. L. Johnson	J. N. Nunnery	G. Ralph

K. Schroeder

R. M. Schuster

R. Zadeh

**Subcommittee 32 – Seismic Design**R. Brockenbrough, *Chairman*

V. D. Azzi

R. Bjorhovde

C. J. Carter

L. R. Daudet

W. S. Easterling

R. B. Haws

B. E. Manley

J. R. U. Mujagic

T. M. Murray

B. W. Schafer

K. Schroeder

W. L. Shoemaker

C. M. Uang

D. P. Watson

K. L. Wood

**Subcommittee 33 – Diaphragm Design**J. Mattingly, *Chairman*

D. Boltz

D. Cobb

J. M. DeFreese

W. S. Easterling

D. Fulton

P. Gignac

W. Gould

A. J. Harrold

W. E. Kile

R. A. LaBoube

D. Li

L. D. Luttrell

J. R. Martin

J. R. U. Mujagic

W. E. Schultz

W. L. Shoemaker

T. Sputo

**CSA Technical Committee on Cold Formed Steel Structural Members**R. M. Schuster, *Chairman*S. R. Fox, *Vice Chairman*

D. Bak

A. F. Caouette

J. J. R. Cheng

D. Delaney

M. K. Madugula

B. Mandelzys

S. S. McCavour

D. Polyzois

N. Schillaci

K. S. Sivakumaran

M. Sommerstein

M. Tancredi

T. W. J. Trestain

R. B. Vincent

**Associate Members**

R. L. Brockenbrough

H. H. Chen

C. Marsh

K. K. Taing

C. Rogers

C. R. Taraschuk

L. Xu



**This Page is Intentionally Left Blank.**

## Personnel

D. Allen	Steel Stud Manufacturers Association
T. Anderson	MIC Industries
V. D. Azzi	Rack Manufacturers Institute
D. Bak	Steelway Building Systems
S. J. Bianculli	United States Steel Corporation
R. Bjorhovde	The Bjorhovde Group
D. Boltz	Wheeling Corrugating Company
R. L. Brockenbrough	R. L. Brockenbrough and Associates
A. Caouette	Canadian Construction Materials Centre
C. J. Carter	American Institute of Steel Construction, Inc.
H. H. Chen	American Iron and Steel Institute
J. J. R. Cheng	University of Alberta
D. Cobb	Loadmaster Systems, Inc.
J. K. Crews	Unarco Material Handling
D. A. Cuoco	Thornton Tomasetti, Inc.
L. R. Daudet	Nucor Building Systems
J. M. DeFreese	Metal Dek Group, CSi
D. Delaney	Flynn Canada Ltd.
W. S. Easterling	Virginia Polytech Institute and State University
D. S. Ellifritt	Consultant
N. Eshwar	Dietrich Design Group
J. M. Fisher	Computerized Structural Design, S.C.
S. R. Fox	Canadian Sheet Steel Building Institute
D. Fulton	Whirlwind Building Systems
P. Gignac	Canam Group Inc.
R. S. Glauz	SPX Cooling Technologies
W. Gould	Hilti, Inc.
P. S. Green	Steel Joist Institute
W. B. Hall	University of Illinois
G. J. Hancock	The University of Sydney
A. J. Harrold	Butler Manufacturing Company
R. B. Haws	NUCONSTEEL Commercial Corp.
D. L. Johnson	Maus Engineering
R. C. Kaehler	Computerized Structural Design, S.C.
W. E. Kile	Structuneering Inc.
R. A. LaBoube	Missouri University of Science and Technology
T. J. Lawson	Dietrich Design Group
D. Li	Canam Steel Corporation
L. Luttrell	Luttrell Engineering, PLLC
M. K. Madugula	University of Windsor
B. Mandelzys	Steelrite
B. E. Manley	American Iron and Steel Institute
C. Marsh	Victoria BC
J. R. Martin	Verco Docking, Inc.
J. P. Matsen	Matsen Ford Design Associates, Inc.
J. A. Mattingly	Consultant
S. S. McCavour	McCavour Engineering Ltd.
W. McRoy	ICC Evaluation Service, Inc.
A. Merchant	NUCONSTEEL Commercial Corp.

T. H. Miller	Oregon State University
C. Moen	Virginia Tech
F. Morello	M.I.C. Industries, Inc.
J. A. Moses	LiteSteel Technologies America, LLC
J. R. U. Mujagic	Uzun and Case Engineers, LLC
T. M. Murray	Consultant
J. N. Nunnery	Consultant
T. B. Pekoz	Consultant
D. Polyzois	University of Manitoba
N. A. Rahman	The Steel Network, Inc.
G. Ralph	Dietrich Industries
C. Ramseyer	University of Oklahoma
C. Rogers	McGill University
V. E. Sagan	Wiss, Janney, Elstner Associates, Inc.
T. Samiappan	TrusSteel Division of ITW Building Comp. Group, Inc.
B. W. Schafer	Johns Hopkins University
N. Schillaci	ArcelorMittal
K. Schroeder	DEVCO Engineering Inc.
W. E. Schultz	Nucor Vulcraft
R. M. Schuster	Consultant
P. A. Seaburg	Consultant
J. Sears	Kirkpatrick Forest Curtis PC
M. Seek	Consultant
D. R. Sherman	East Tennessee State University
W. L. Shoemaker	Metal Building Manufacturers Association
K. S. Sivakumaran	McMaster University
M. Sommerstein	M&H Engineering
T. Sputo	Sputo and Lammert Engineering
K. Taing	PauTech Corporation
M. Tancredi	GenesisTP Inc.
C.R. Taraschuk	National Research Council Canada
T. W. J. Trestain	T. W. J. Trestain Structural Engineering
C. M. Uang	University of California at San Diego
R. Vincent	Canam Group Inc.
J. Walsh	American Buildings Company
D. P. Watson	B C Steel
K. L. Wood	K. L. Wood Engineering
L. Xu	University of Waterloo
C. Yu	University of North Texas
R. Zadeh	Marino/Ware

**TABLE OF CONTENTS**  
**SUPPLEMENT NO. 2 TO THE NORTH AMERICAN SPECIFICATION**  
**FOR THE DESIGN OF COLD-FORMED STEEL**  
**STRUCTURAL MEMBERS, 2007 EDITION**  
**AND THE COMMENTARY**

**FEBRUARY 2010**

<b>PREFACE.....</b>	<b>III</b>
<b>SUPPLEMENT NO. 2 TO THE NORTH AMERICAN SPECIFICATION FOR THE DESIGN OF COLD-FORMED STEEL STRUCTURAL MEMBERS, 2007 EDITION .....</b>	<b>1</b>
<b>CHANGES AND UPDATES IN SYMBOLS AND DEFINITIONS.....</b>	<b>1</b>
<b>CHANGES AND UPDATES IN CHAPTER A, GENERAL PROVISIONS.....</b>	<b>1</b>
<b>CHANGES AND UPDATES IN CHAPTER B, ELEMENTS .....</b>	<b>1</b>
B2.5    Uniformly Compressed Elements Restrained by Intermittent Connections .....	1
B5.1.1  Specific Case: Single or n Identical Stiffeners, Equally Spaced.....	3
<b>CHANGES AND UPDATES IN CHAPTER C, MEMBERS.....</b>	<b>3</b>
C2    Tension Members .....	3
C2.1    Yielding of Gross Section .....	3
C2.2    Rupture of Net Section .....	3
C3.1.4  Distortional Buckling Strength [Resistance].....	4
C4.2    Distortional Buckling Strength [Resistance].....	7
<b>CHANGES AND UPDATES IN CHAPTER D, STRUCTURAL ASSEMBLIES AND SYSTEMS.....</b>	<b>9</b>
D1.1    Flexural Members Composed of Two Back-to-Back C-Sections.....	9
D3    Lateral and Stability Bracing.....	10
D3.1    Symmetrical Beams and Columns .....	11
<b>CHANGES AND UPDATES IN CHAPTER E, CONNECTIONS AND JOINTS .....</b>	<b>11</b>
E.    CONNECTIONS AND JOINTS.....	12
E1    General Provisions .....	12
E2    Welded Connections.....	12
E2.1    Groove Welds in Butt Joints.....	12
E2.2    Arc Spot Welds .....	13
E2.2.2    Shear.....	14
E2.2.3    Tension.....	17
E2.2.4    Combined Shear and Tension on an Arc Spot Weld.....	17
E2.3    Arc Seam Welds.....	19
E2.3.1    Minimum Edge and End Distance.....	19
E2.3.2    Shear.....	20
E2.4    Fillet Welds.....	21
E2.5    Flare Groove Welds.....	22
E2.6    Resistance Welds .....	26
E3    Bolted Connections .....	26
E3.1    Minimum Spacing.....	27
E3.2    Minimum Edge and End Distances .....	27
E3.3    Bearing .....	28
E3.3.1    Bearing Strength [Resistance] without Consideration of Bolt Hole Deformation .....	28

E3.3.2	Bearing Strength [Resistance] with Consideration of Bolt Hole Deformation	29
E3.4	Shear and Tension in Bolts .....	29
E4	Screw Connections .....	29
E4.1	Minimum Spacing .....	30
E4.2	Minimum Edge and End Distances .....	30
E4.3	Shear .....	30
E4.3.1	Shear Strength [Resistance] Limited by Tilting and Bearing .....	30
E4.3.2	Shear in Screws .....	30
E4.4	Tension .....	31
E4.4.1	Pull-Out Strength [Resistance] .....	31
E4.4.2	Pull-Over Strength [Resistance] .....	31
E4.4.3	Tension in Screws .....	32
E4.5	Combined Shear and Pull-Over .....	33
E4.5.1	ASD Method .....	33
E4.5.2	LRFD and LSD Methods .....	33
E5	Rupture .....	34
E5.1	Shear Rupture .....	34
E5.2	Tension Rupture .....	35
E5.3	Block Shear Rupture .....	36
E6	Connections to Other Materials .....	37
E6.1	Bearing .....	37
E6.2	Tension .....	37
E6.3	Shear .....	37
	<b>CHANGES AND UPDATES CHAPTER F, TESTS FOR SPECIAL CASES .....</b>	<b>38</b>
	<b>CHANGES AND UPDATES IN APPENDIX 1 .....</b>	<b>39</b>
	<b>CHANGES AND UPDATES IN APPENDIX A .....</b>	<b>40</b>
E2a	Welded Connections .....	40
E3a	Bolted Connections .....	40
E3.4	Shear and Tension in Bolts .....	41
E5a	Rupture .....	43
E5a	Rupture .....	44
	<b>CHANGES AND UPDATES IN APPENDIX B .....</b>	<b>45</b>
E2a	Welded Connections .....	45
E2.2a	Arc Spot Welds .....	45
E2.3a	Arc Seam Welds .....	45
E3a	Bolted Connections .....	45
E3.3a	Bearing .....	46
E3.4	Shear and Tension in Bolts .....	46
E5a	Rupture .....	47

<b>COMMENTARY ON SUPPLEMENT NO. 2 TO THE NORTH AMERICAN SPECIFICATION FOR THE DESIGN OF COLD-FORMED STEEL STRUCTURAL MEMBERS, 2007 EDITION .....</b>	<b>C-1</b>
<b>CHANGES AND UPDATES TO CHAPTER A THROUGH F .....</b>	<b>C-1</b>
<b>CHANGES AND UPDATES IN COMMENTARY ON CHAPTER B, ELEMENTS .....</b>	<b>C-1</b>
B2.5    Uniformly Compressed Elements Restrained by Intermittent Connections .....	C-1
<b>CHANGES AND UPDATES IN COMMENTARY ON CHAPTER C, MEMBERS .....</b>	<b>C-2</b>
C3.1.4    Distortional Buckling Strength [Resistance] .....	C-3
C4.2    Distortional Buckling Strength [Resistance] .....	C-8
<b>CHANGES AND UPDATES IN CHAPTER D, STRUCTURAL ASSEMBLIES AND SYSTEMS .....</b>	<b>C-12</b>
<b>CHANGES AND UPDATES IN COMMENTARY ON CHAPTER E, CONNECTIONS AND JOINTS .....</b>	<b>C-13</b>
E.    CONNECTIONS AND JOINTS .....	C-13
E1    General Provisions .....	C-13
E2    Welded Connections .....	C-14
E2.1    Groove Welds in Butt Joints .....	C-15
E2.2    Arc Spot Welds .....	C-15
E2.2.1    Minimum Edge and End Distance .....	C-15
E2.2.2    Shear .....	C-16
E2.2.3    Tension .....	C-17
E2.2.4    Combined Shear and Tension on an Arc Spot Weld .....	C-18
E2.3    Arc Seam Welds .....	C-18
E2.3.2    Shear .....	C-18
E2.4    Fillet Welds .....	C-19
E2.5    Flare Groove Welds .....	C-20
E2.6    Resistance Welds .....	C-20
E3    Bolted Connections .....	C-21
E3.3    Bearing .....	C-23
E3.3.1    Strength [Resistance] Without Consideration of Bolt Hole Deformation ..	C-23
E3.3.2    Strength [Resistance] With Consideration of Bolt Hole Deformation .....	C-23
E3.4    Shear and Tension in Bolts .....	C-23
E4    Screw Connections .....	C-24
E4.1    Minimum Spacing .....	C-25
E4.2    Minimum Edge and End Distances .....	C-25
E4.3    Shear .....	C-25
E4.3.1    Shear Strength [Resistance] Limited by Tilting and Bearing .....	C-25
E4.3.2    Shear in Screws .....	C-25
E4.4    Tension .....	C-26
E4.4.1    Pull-Out Strength [Resistance] .....	C-26
E4.4.2    Pull-Over Strength [Resistance] .....	C-26
E4.4.3    Tension in Screws .....	C-26
E4.5    Combined Shear and Pull-Over .....	C-27
E5    Rupture .....	C-27
E6    Connections to Other Materials .....	C-32
E6.1    Bearing .....	C-32
E6.2    Tension .....	C-32
E6.3    Shear .....	C-32
<b>CHANGES AND UPDATES IN COMMENTARY ON CHAPTER F, TESTS FOR SPECIAL CASES .....</b>	<b>C-33</b>
F1.1    Load and Resistance Factor Design and Limit States Design .....	C-33
<b>CHANGES AND UPDATES IN APPENDIX 1 .....</b>	<b>C-36</b>

<b>UPDATE REFERENCES</b> .....	<b>C-37</b>
<b>CHANGES AND UPDATES IN COMMENTARY ON APPENDIX A</b> .....	<b>C-38</b>
E2a    Welded Connections.....	C-38
E3a    Bolted Connections .....	C-38
E3.4    Shear and Tension in Bolts.....	C-38
<b>CHANGES AND UPDATES IN COMMENTARY ON APPENDIX B</b> .....	<b>C-40</b>
E2a    Welded Connections.....	C-40
E3 Bolted Connections .....	C-40
E3.3 Bearing .....	C-40
E5a    Rupture .....	C-40

**SUPPLEMENT NO. 2 TO THE NORTH AMERICAN SPECIFICATION  
FOR THE DESIGN OF COLD-FORMED STEEL  
STRUCTURAL MEMBERS, 2007 EDITION**

**FEBRUARY 2010**

**CHANGES AND UPDATES IN SYMBOLS AND DEFINITIONS**

1. On pages xvii and 41, change the definition of  $h_x$  to  
 $h_{xf} = x$  distance from the centroid of the flange to the flange/web junction
2. On pages xxvii and 41, change the definition of  $x_o$  used in Sections C3.1.4 and C4.2 to  
 $x_{of} = x$  distance from the centroid of the flange to the shear center of the flange
3. On pages xxviii and 42, change the definition of  $y_o$  to  
 $y_{of} = y$  distance from the centroid of the flange to the shear center of the flange

**CHANGES AND UPDATES IN CHAPTER A, GENERAL PROVISIONS**

1. On Page 1, change the second paragraph under Section A1.2 as follows:  
“Symbol  $\Rightarrow^x$  is used to point out that additional provisions that are specific to a certain country are provided in the corresponding appendix as indicated by the letter(s), x.”
2. On page 13, add the following reference before reference AISI S214:  
AISI S213-07/S1, North American Standard for Cold-Formed Steel Framing – Lateral Design with Supplement No. 1

**CHANGES AND UPDATES IN CHAPTER B, ELEMENTS**

1. Add Section B2.5, Uniformly Compressed Elements Restrained by Intermittent Connections, as follows:

**B2.5 Uniformly Compressed Elements Restrained by Intermittent Connections**

The provisions of this section shall apply to compressed elements of flexural members only. The provisions shall be limited to multiple flute built-up members having edge stiffened cover plates. When the spacing of fasteners,  $s$ , of a uniformly compressed element restrained by intermittent connections is not greater than the limits specified in Section D1.3, the effective width shall be calculated in accordance with Section B2.1. When the spacing of fasteners is greater than the limits specified in Section D1.3, the effective width shall be determined in accordance with (a) and (b) below.

*(a) Strength Determination*

The effective width of the uniformly compressed element restrained by intermittent connections shall be determined as follows:

- (1) When  $f < F_c$ , the effective width of the compression element between connection lines shall be calculated in accordance with Section B2.1(a).



- (2) When  $f \geq F_c$  the effective width of the compression element between connection lines shall be calculated in accordance with Section B2.1(a), except that the reduction factor  $\rho$  shall be determined as follows:

$$\rho = \rho_t \rho_m \quad (\text{Eq. B2.5-1})$$

where

$$\rho_t = (1 - 0.22/\lambda_t)/\lambda_t \leq 1 \quad (\text{Eq. B2.5-2})$$

where

$$\lambda_t = \sqrt{\frac{F_c}{F_{cr}}} \quad (\text{Eq. B2.5-3})$$

$F_c$  = Critical column buckling stress of compression element

$$= 3.29 E/(s/t)^2 \quad (\text{Eq. B2.5-4})$$

where

$s$  = Center to center spacing of connectors in the line of compression stress

$E$  = Modulus of elasticity of steel

$t$  = Thickness of cover plate in compression;

$F_{cr}$  = Defined in Eq. B2.1-5 where  $w$  is the maximum transverse spacing of connectors

$$\rho_m = 8 \left( \frac{F_y}{f} \right) \sqrt{\frac{t F_c}{d f}} \leq 1.0 \quad (\text{Eq. B2.5-5})$$

where

$F_y$  = Design yield stress of the compression element restrained by intermittent connections

$d$  = Overall depth of the built-up member

$f$  = Stress in compression element restrained by intermittent connections when the controlling extreme fiber stress is  $F_y$ .

The above equations shall meet the following limits:

$$1.5 \text{ in. (38 mm)} \leq d \leq 7.5 \text{ in. (191 mm)}$$

$$0.035 \text{ in. (0.9 mm)} \leq t \leq 0.060 \text{ in. (1.5 mm)}$$

$$2.0 \text{ in. (51 mm)} \leq s \leq 8.0 \text{ in. (203 mm)}$$

$$33 \text{ ksi (228 MPa)} \leq F_y \leq 60 \text{ ksi (414 MPa)}$$

$$100 \leq w/t \leq 350$$

The provisions of this section shall not apply to single flute members having compression plates with edge stiffeners.

*(b) Serviceability Determination*

The effective width of the uniformly compressed element restrained by intermittent connections used for computing deflection shall be determined in accordance with Section B2.5(a) except that: 1)  $f_d$  shall be substituted for  $f$ , where  $f_d$  is the computed compression stress in the element being considered at service load, and 2) the maximum extreme fiber stress in the built up member shall be substituted for  $F_y$ .

2. On page 29, revise the title, the first paragraph and Eq. B5.1.1-1 of Section B5.1.1 as follows:

**B5.1.1 Specific Case: Single or n Identical Stiffeners, Equally Spaced**

For uniformly compressed elements with single, or multiple identical and equally spaced stiffeners, the plate *buckling* coefficients and *effective widths* shall be calculated as follows:

(a) *Strength Determination*

$$k_{loc} = 4(b_o/b_p)^2 \quad (\text{Eq. B5.1.1-1})$$

.....

3. On page 29, revise the first paragraph under Section B5.1.2 to

“For uniformly compressed stiffened elements with stiffeners of arbitrary size, location and number, the plate buckling coefficients and effective widths shall be calculated as follows.”

**CHANGES AND UPDATES IN CHAPTER C, MEMBERS**

1. Replace Section C2 with the following:

**C2 Tension Members**

For axially loaded tension members, the *available tensile strength [factored resistance]* shall be the lesser of the values obtained in accordance with Sections C2.1 and C2.2, where the *nominal strengths [resistance]* and the corresponding *safety* and *resistance factors* are provided. The *available strengths* shall be determined in accordance with the applicable method in Section A4, A5, or A6.

The nominal tensile strength [resistance] shall also be limited by the connection strength of the tension members, which is determined in accordance with the provisions of Chapter E.

**C2.1 Yielding of Gross Section**

The *nominal tensile strength [resistance]*,  $T_n$ , due to yielding of the gross section shall be determined as follows:

$$T_n = A_g F_y \quad (\text{Eq. C2.1-1})$$

$$\Omega_t = 1.67 \quad (\text{ASD})$$

$$\phi_t = 0.90 \quad (\text{LRFD})$$

$$= 0.90 \quad (\text{LSD})$$

where

$A_g$  = Gross area of cross section

$F_y$  = Design yield stress as determined in accordance with Section A7.1

**C2.2 Rupture of Net Section**

The *nominal tensile strength [resistance]*,  $T_n$ , due to rupture of the net section shall be determined as follows:

$$T_n = A_n F_u \quad (\text{Eq. C2-2})$$

$$\Omega_t = 2.00 \quad (\text{ASD})$$

$$\phi_t = 0.75 \quad (\text{LRFD})$$

$$= 0.75 \quad (\text{LSD})$$

where

$A_n$  = Net area of cross section

$F_u$  = Tensile strength as specified in either Section A2.1 or A2.3.2

2. On page 32, revise the first paragraph under Section C3.1 as follows:

“The *design flexural strength [moment resistance]*,  $\phi_b M_n$ , and the *allowable flexural strength*,  $M_n/\Omega_b$ , shall be the smallest of the values calculated in accordance with sections C3.1.1, C3.1.2, C3.1.3, C3.1.4, D6.1.1, D6.1.2, and D6.2.1, where applicable.”

3. On page 32, delete lines 7 to 11 under Section C3.1.1.

4. On page 34, add the following definition before  $\lambda_3$ :

“ $\lambda$  = Slenderness factor defined in Section B3.2”

5. Replace Section C3.1.4 with the following:

#### **C3.1.4 Distortional Buckling Strength [Resistance]**

The provisions of this section shall apply to I-, Z-, C-, and other open cross-section members that employ compression flanges with edge stiffeners, with the exception of members that meet the criteria of Section D6.1.1, D6.1.2 when the R factor of Eq. D6.1.2-1 is employed, or D6.2.1. The *nominal flexural strength [moment resistance]* shall be calculated in accordance with Eq. C3.1.4-1 or Eq. C3.1.4-2. The *safety factor* and *resistance factors* given in this section shall be used to determine the *allowable flexural strength* or *design flexural strength [factored moment resistance]* in accordance with the applicable design method in Section A4, A5, or A6.

$$\Omega_b = 1.67 \quad (\text{ASD})$$

$$\phi_b = 0.90 \quad (\text{LRFD})$$

$$= 0.85 \quad (\text{LSD})$$

For  $\lambda_d \leq 0.673$

$$M_n = M_y \quad (\text{Eq. C3.1.4-1})$$

For  $\lambda_d > 0.673$

$$M_n = \left( 1 - 0.22 \left( \frac{M_{\text{crd}}}{M_y} \right)^{0.5} \right) \left( \frac{M_{\text{crd}}}{M_y} \right)^{0.5} M_y \quad (\text{Eq. C3.1.4-2})$$

where

$$\lambda_d = \sqrt{M_y / M_{\text{crd}}} \quad (\text{Eq. C3.1.4-3})$$

$$M_y = S_{fy} F_y \quad (\text{Eq. C3.1.4-4})$$

where

$S_{fy}$  = Elastic section modulus of full unreduced section relative to extreme fiber in first yield

$$M_{CrD} = S_f F_d \quad (\text{Eq. C3.1.4-5})$$

where

$S_f$  = Elastic section modulus of full unreduced section relative to extreme compression fiber

$F_d$  = Elastic *distortional buckling stress* calculated in accordance with either Section C3.1.4(a) or (b)

(a) For C- and Z-Sections or any Open Section with a Stiffened Compression Flange Extending to One Side of the Web where the Stiffener is either a Simple Lip or a Complex Edge Stiffener

The provisions of this section shall be permitted to apply to any open section with a single *web* and single edge stiffened compression flange. The distortional buckling stress,  $F_d$ , shall be calculated in accordance with Eq. C3.1.4-6 as follows:

$$F_d = \beta \frac{k_{\phi fe} + k_{\phi we} + k_{\phi}}{\tilde{k}_{\phi fg} + \tilde{k}_{\phi wg}} \quad (\text{Eq. C3.1.4-6})$$

where

$\beta$  = A value accounting for moment gradient, which is permitted to be conservatively taken as 1.0

$$= 1.0 \leq 1 + 0.4(L/L_m)^{0.7} (1 + M_1/M_2)^{0.7} \leq 1.3 \quad (\text{Eq. C3.1.4-7})$$

where

$L$  = Minimum of  $L_{cr}$  and  $L_m$

where

$$L_{cr} = \left( \frac{4\pi^4 h_o (1 - \mu^2)}{t^3} \left( I_{xf} (x_{of} - h_{xf})^2 + C_{wf} - \frac{I_{xyf}^2}{I_{yf}} (x_{of} - h_{xf})^2 \right) + \frac{\pi^4 h_o^4}{720} \right)^{1/4} \quad (\text{Eq. C3.1.4-8})$$

where

$h_o$  = Out-to-out web depth as defined in Figure B2.3-2

$\mu$  = Poisson's ratio

$t$  = Base steel thickness

$I_{xf}$  = x-axis moment of inertia of the flange

$x_{of}$  = x distance from the centroid of the flange to the shear center of the flange

$h_{xf}$  = x distance from the centroid of the flange to the flange/web junction

$C_{wf}$  = Warping torsion constant of the flange

$I_{xyf}$  = Product of the moment of inertia of the flange

$I_{yf}$  = y-axis moment of inertia of the flange

In the above,  $I_{xf}$ ,  $I_{yf}$ ,  $I_{xyf}$ ,  $C_{wf}$ ,  $x_{of}$ , and  $h_{xf}$  are properties of the compression flange plus edge stiffener about an x-y axis system located at the centroid of the flange, with the x-axis measured positive to the right from the centroid,

and the y-axis positive down from the centroid.

$L_m$  = Distance between discrete restraints that restrict distortional buckling  
(for continuously restrained members  $L_m=L_{cr}$ )

$M_1$  and  $M_2$  = The smaller and the larger end moments, respectively, in the unbraced segment ( $L_m$ ) of the beam;  $M_1/M_2$  is positive when the moments cause reverse curvature and negative when bent in single curvature

$$k_{\phi fe} = \text{Elastic rotational stiffness provided by the flange to the flange/web juncture}$$

$$= \left(\frac{\pi}{L}\right)^4 \left[ EI_{xf}(x_{of} - h_{xf})^2 + EC_{wf} - E \frac{I_{xyf}^2}{I_{yf}}(x_{of} - h_{xf})^2 \right] + \left(\frac{\pi}{L}\right)^2 GJ_f \quad (\text{Eq. C3.1.4-9})$$

where

$E$  = Modulus of elasticity of steel

$G$  = Shear modulus

$J_f$  = St. Venant torsion constant of the compression flange, plus edge stiffener about an x-y axis located at the centroid of the flange, with the x-axis measured positive to the right from the centroid, and the y-axis positive down from the centroid

$$k_{\phi we} = \text{Elastic rotational stiffness provided by the web to the flange/web juncture}$$

$$= \frac{Et^3}{12(1-\mu^2)} \left( \frac{3}{h_o} + \left(\frac{\pi}{L}\right)^2 \frac{19h_o}{60} + \left(\frac{\pi}{L}\right)^4 \frac{h_o^3}{240} \right) \quad (\text{Eq. C3.1.4-10})$$

$k_\phi$  = Rotational stiffness provided by a restraining element (brace, panel, sheathing) to the flange/web juncture of a member (zero if the compression flange is unrestrained)

$\tilde{k}_{\phi fg}$  = Geometric rotational stiffness (divided by the stress  $F_d$ ) demanded by the flange from the flange/web juncture

$$= \left(\frac{\pi}{L}\right)^2 \left[ A_f \left[ (x_{of} - h_{xf})^2 \left(\frac{I_{xyf}}{I_{yf}}\right)^2 - 2y_{of}(x_{of} - h_{xf}) \left(\frac{I_{xyf}}{I_{yf}}\right) + h_{xf}^2 + y_{of}^2 \right] + I_{xf} + I_{yf} \right] \quad (\text{Eq. C3.1.4-11})$$

where

$A_f$  = Cross-sectional area of the compression flange plus edge stiffener about an x-y axis located at the centroid of the flange, with the x-axis measured positive to the right from the centroid, and the y-axis positive down from the centroid

$y_{of}$  = y distance from the centroid of the flange to the shear center of the flange

$\tilde{k}_{\phi wg}$  = Geometric rotational stiffness (divided by the stress  $F_d$ ) demanded by the web from the flange/web juncture

$$= \frac{h_o t \pi^2}{13440} \left( \frac{[45360(1 - \xi_{web}) + 62160] \left(\frac{L}{h_o}\right)^2 + 448\pi^2 + \left(\frac{h_o}{L}\right)^2 [53 + 3(1 - \xi_{web})] \pi^4}{\pi^4 + 28\pi^2 \left(\frac{L}{h_o}\right)^2 + 420 \left(\frac{L}{h_o}\right)^4} \right) \quad (Eq. C3.1.4-12)$$

where

$\xi_{web} = (f_1 - f_2)/f_1$ , stress gradient in the web, where  $f_1$  and  $f_2$  are the stresses at the opposite ends of the web,  $f_1 > f_2$ , compression is positive, tension is negative, and the stresses are calculated on the basis of the gross section, (e.g., pure symmetrical bending,  $f_1 = -f_2$ ,  $\xi_{web} = 2$ )

(b) *Rational Elastic Buckling Analysis*

A rational elastic *buckling* analysis that considers distortional buckling shall be permitted to be used in lieu of the expressions given in Section C3.1.4 (a). The safety and resistance factors in Section C3.1.4 shall apply.

6. On page 44, change the second paragraph under Section C3.3.1 to:

“For beams without shear stiffeners as defined in Section C3.7.3, the required flexural strength,  $M$ , and required shear strength,  $V$ , shall also satisfy the following interaction equation:”

And on page 45, change the first paragraph to:

“For beams with shear stiffeners as defined in Section C3.7.3, when  $\Omega_b M/M_{nxo} > 0.5$  and  $\Omega_v V/V_n > 0.7$ ,  $M$  and  $V$  shall also satisfy the following interaction equation:”

7. On page 45, change the second paragraph under Section C3.3.2 to:

“For beams without shear stiffeners as defined in Section C3.7.3, the required flexural strength [factored moment],  $\bar{M}$ , and the required shear strength [factored shear],  $\bar{V}$ , shall also satisfy the following interaction equation:”

And on page 45, change the third paragraph under Section C3.3.2 to:

“For beams with shear stiffeners as defined in Section C3.7.3, when  $\bar{M}/(\phi_b M_{nxo}) > 0.5$  and  $\bar{V}/(\phi_v V_n) > 0.7$ ,  $\bar{M}$  and  $\bar{V}$  shall also satisfy the following interaction equation:”

8. On page 51, revise “ $d_0$ ” in item (9) to “ $d_h$ ”.
9. Replace Section C4.2 with the following:

#### **C4.2 Distortional Buckling Strength [Resistance]**

The provisions of this section shall apply to I-, Z-, C-, Hat, and other open cross-section members that employ flanges with edge stiffeners, with the exception of members that are designed in accordance with Section D6.1.3 or D6.1.4. The *nominal axial strength* [compressive resistance] shall be calculated in accordance with Eqs. C4.2-1 and C4.2-2. The *safety factor* and *resistance factors* in this section shall be used to determine the allowable compressive strength or design compressive strength [resistance] in accordance with the applicable design method in Section A4, A5, or A6.

$$\begin{aligned}\Omega_c &= 1.80 \quad (ASD) \\ \phi_c &= 0.85 \quad (LRFD) \\ &= 0.80 \quad (LSD)\end{aligned}$$

For  $\lambda_d \leq 0.561$

$$P_n = P_y \quad (Eq. C4.2-1)$$

For  $\lambda_d > 0.561$

$$P_n = \left( 1 - 0.25 \left( \frac{P_{crd}}{P_y} \right)^{0.6} \right) \left( \frac{P_{crd}}{P_y} \right)^{0.6} P_y \quad (Eq. C4.2-2)$$

where

$$\lambda_d = \sqrt{P_y / P_{crd}} \quad (Eq. C4.2-3)$$

$P_n$  = Nominal axial strength

$$P_y = A_g F_y \quad (Eq. C4.2-4)$$

where

$A_g$  = Gross area of the cross-section

$F_y$  = Yield stress

$$P_{crd} = A_g F_d \quad (Eq. C4.2-5)$$

where

$F_d$  = Elastic *distortional buckling stress* calculated in accordance with either Section C4.2(a) or (b)

(a) For C- and Z-Sections or Hat Sections or any Open Section with Stiffened Flanges of Equal Dimension where the Stiffener is either a Simple Lip or a Complex Edge Stiffener

The provisions of this section shall apply to any open section with stiffened flanges of equal dimension.

$$F_d = \frac{k_{\phi fe} + k_{\phi we} + k_{\phi}}{\tilde{k}_{\phi fg} + \tilde{k}_{\phi wg}} \quad (Eq. C4.2-6)$$

where

$k_{\phi fe}$  = Elastic rotational stiffness provided by the flange to the flange/web juncture, in accordance with Eq. C3.1.4-9

$k_{\phi we}$  = Elastic rotational stiffness provided by the web to the flange/web juncture

$$= \frac{Et^3}{6h_o(1-\mu^2)} \quad (Eq. C4.2-7)$$

$k_{\phi}$  = Rotational stiffness provided by restraining elements (brace, panel, sheathing) to the flange/web juncture of a member (zero if the flange is unrestrained). If rotational stiffness provided to the two flanges is dissimilar, the smaller rotational stiffness is used.

$\tilde{k}_{\phi fg}$  = Geometric rotational stiffness (divided by the stress  $F_d$ ) demanded by the flange from the flange/web juncture, in accordance with Eq. C3.1.4-11

$$\begin{aligned}\tilde{k}_{\phi wg} &= \text{Geometric rotational stiffness (divided by the stress } F_d) \text{ demanded by the} \\ &\quad \text{web from the flange/web juncture} \\ &= \left(\frac{\pi}{L}\right)^2 \frac{th_o^3}{60}\end{aligned}\quad (\text{Eq. C4.2-8})$$

where

$L$  = Minimum of  $L_{cr}$  and  $L_m$

where

$$L_{cr} = \left[ \frac{6\pi^4 h_o (1 - \mu^2)}{t^3} \left( I_{xf} (x_{of} - h_{xf})^2 + C_{wf} - \frac{I_{xyf}^2}{I_{yf}} (x_{of} - h_{xf})^2 \right) \right]^{1/4} \quad (\text{Eq. C4.2-9})$$

$L_m$  = Distance between discrete restraints that restrict distortional buckling  
(for continuously restrained members  $L_m = L_{cr}$ )

See Section C3.1.4 (a) for definition of variables in Eq. C4.2-9.

(b) *Rational elastic buckling analysis*

A rational elastic buckling analysis that considers distortional buckling shall be permitted to be used in lieu of the expressions given in Section C4.2(a). The safety and resistance factors in Section C4.2 shall apply.

## CHANGES AND UPDATES IN CHAPTER D, STRUCTURAL ASSEMBLIES AND SYSTEMS

1. On page 68, replace Section D1.1 as follows:

### D1.1 Flexural Members Composed of Two Back-to-Back C-Sections

The maximum longitudinal spacing of connections (one or more welds or other connectors),  $s_{max}$ , joining two C-sections to form an I-section shall be:

$$s_{max} = L / 6 \text{ or } \frac{2gT_s}{mq}, \text{ whichever is smaller} \quad (\text{Eq. D1.1-1})$$

where

$L$  = Span of beam

$g$  = Vertical distance between two rows of *connections* nearest to top and bottom flanges

$T_s$  = Available strength [factored resistance] of connection in tension (Chapter E)

$m$  = Distance from shear center of one C-section to mid-plane of *web*

$q$  = Design load [factored load] on beam for determining longitudinal spacing of connections (See below for methods of determination.)

The load,  $q$ , shall be obtained by dividing the concentrated loads or reactions by the length of bearing. For beams designed for a uniformly distributed load,  $q$  shall be taken as equal to three times the uniformly distributed load, based on the critical load combinations for ASD, LRFD, and LSD.

If the length of bearing of a concentrated load or reaction is smaller than the longitudinal connection spacing,  $s$ , the required strength [effect of factored loads] of the connections closest to the load or reaction shall be calculated as follows:



$$T_r = P_s m / 2g \quad (\text{Eq. D1.1-2})$$

where

$P_s$  = Concentrated load [factored load] or reaction based on critical load combinations for ASD, LRFD, and LSD

$T_r$  = Required strength [effect of factored loads] of connection in tension

The allowable maximum spacing of connections,  $s_{\max}$ , shall depend upon the intensity of the load directly at the connection. Therefore, if uniform spacing of connections is used over the whole length of the beam, it shall be determined at the point of maximum local load intensity. In cases where this procedure would result in uneconomically close spacing, either one of the following methods shall be permitted to be adopted:

- (a) the connection spacing varies along the beam according to the variation of the load intensity, or
- (b) reinforcing cover plates are welded to the flanges at points where concentrated loads occur. The available shear strength [factored resistance] of the connections joining these plates to the flanges is then used for  $T_r$ , and  $g$  is taken as the depth of the beam.

2. On page 69, revise the last paragraph in Section D1.2 as follows:

- (3) The intermediate fastener(s) or weld(s) at any longitudinal member tie location are capable of transmitting required strength in any direction of 2.5 percent of the available axial strength [factored axial resistance] of the built-up member.

3. On page 69, revise the first sentence of the first paragraph in Section D1.3 as follows:

“To develop the *required strength* of the compression element, the spacing,  $s$ , in the line of *stress*, of welds, rivets, or bolts connecting a cover plate, sheet, or a non-integral stiffener in compression to another element shall not exceed (a), (b), and (c) as follows:”

4. Add the following paragraph to the end of Section D1.3:

“When any of the limits (a), (b), or (c) in this section are exceeded, the effective width shall be determined in accordance with Section B2.5.”

5. On page 70, revise Sections D3 and D3.1 as follows:

### **D3 Lateral and Stability Bracing**

Braces and bracing systems, including connections, shall be designed with adequate strength and stiffness to restrain lateral bending or twisting of a loaded beam or column, and to avoid local crippling at the points of attachment. Braces and bracing systems, including *connections*, shall also be designed considering strength and stiffness requirements, as applicable.

C-Section and Z-Section beam bracing shall meet the requirements specified in Section D3.2.

Bracing of axially loaded compression members shall meet the requirements as specified in Section D3.3.

See Appendix B for additional requirements applicable to Canada.

→B

### **D3.1 Symmetrical Beams and Columns**

The provision of this section shall only apply to Canada. See Section D3.1 of Appendix B.  **B**

6. On page 70, revise the last sentence of the first paragraph under Section D3.2 to “Also, see Appendix B for additional requirements applicable to Canada.”
7. On page 73, add the following to the end of Section D4, and delete “  **A** “:
  - (e) Light-framed shear walls, diagonal strap bracing (that is part of a structural wall) and diaphragms to resist wind, seismic and other in-plane lateral loads shall be designed in accordance with AISI S213.
8. On page 75, change item (14) to “(14) The design yield stress of the member does not exceed 60 ksi (410 MPa or 4220 kg/cm<sup>2</sup>).”
9. In Table D6.3.1-1 on page 81, for Multiple Spans, with SS Roofs and Exterior Frame Line, change the value for C2 from “1.3” to “13”.

### **CHANGES AND UPDATED IN CHAPTER E, CONNECTIONS AND JOINTS**

Replace the entire Chapter E with the following:

## E. CONNECTIONS AND JOINTS

### E1 General Provisions

*Connections* shall be designed to transmit the *required strength* [factored loads] acting on the connected members with consideration of eccentricity where applicable.

### E2 Welded Connections

The following design criteria shall apply to welded *connections* used for *cold-formed steel structural members* in which the *thickness* of the thinnest connected part is 3/16 in. (4.76 mm) or less. For the design of welded connections in which the thickness of the thinnest connected part is greater than 3/16 in. (4.76 mm), the specifications or standards stipulated in the corresponding Section E2a of Appendix A or B shall be followed. ⇒ **A,B**

Welds shall follow the requirements of the weld standards also stipulated in Section E2a of Appendix A or B. For *diaphragm* applications, Section D5 shall apply. ⇒ **A,B**

#### E2.1 Groove Welds in Butt Joints

The *nominal strength* [resistance],  $P_n$ , of a groove weld in a *butt joint*, welded from one or both sides, shall be determined in accordance with (a) or (b), as applicable. The corresponding *safety factor* and *resistance factors* shall be used to determine the *allowable strength* or *design strength* [factored resistance] in accordance with the applicable design method in Section A4, A5, or A6.

- (a) For tension or compression normal to the effective area, the nominal strength [resistance],  $P_n$ , shall be calculated in accordance with Eq. E2.1-1:

$$P_n = L t_e F_y \quad (\text{Eq. E2.1-1})$$

$$\Omega = 1.70 \quad (\text{ASD})$$

$$\phi = 0.90 \quad (\text{LRFD})$$

$$= 0.80 \quad (\text{LSD})$$

- (b) For shear on the effective area, the nominal strength [resistance],  $P_n$ , shall be the smaller value calculated in accordance with Eqs. E2.1-2 and E2.1-3:

$$P_n = L t_e 0.6 F_{xx} \quad (\text{Eq. E2.1-2})$$

$$\Omega = 1.90 \quad (\text{ASD})$$

$$\phi = 0.80 \quad (\text{LRFD})$$

$$= 0.70 \quad (\text{LSD})$$

$$P_n = L t_e F_y / \sqrt{3} \quad (\text{Eq. E2.1-3})$$

$$\Omega = 1.70 \quad (\text{ASD})$$

$$\phi = 0.90 \quad (\text{LRFD})$$

$$= 0.80 \quad (\text{LSD})$$

where

$P_n$  = Nominal strength [resistance] of groove weld

$L$  = Length of weld

$t_e$  = Effective throat dimension of groove weld

$F_y$  = Yield stress of lowest strength base steel  
 $F_{xx}$  = Tensile strength of electrode classification

## E2.2 Arc Spot Welds

Arc spot welds, where permitted by this *Specification*, shall be for welding sheet steel to thicker supporting members or sheet-to-sheet in the flat position. Arc spot welds (puddle welds) shall not be made on steel where the thinnest sheet exceeds 0.15 in. (3.81 mm) in thickness, nor through a combination of steel sheets having a total thickness over 0.15 in. (3.81 mm).

Weld washers, as shown in Figures E2.2-1 and E2.2-2, shall be used where the thickness of the sheet is less than 0.028 in. (0.711 mm). Weld washers shall have a thickness between 0.05 in. (1.27 mm) and 0.08 in. (2.03 mm) with a minimum prepunched hole of 3/8 in. (9.53 mm) diameter. Sheet-to-sheet welds shall not require weld washers.

Arc spot welds shall be specified by minimum effective diameter of fused area,  $d_e$ . The minimum allowable effective diameter shall be 3/8 in. (9.5 mm). ➔ B

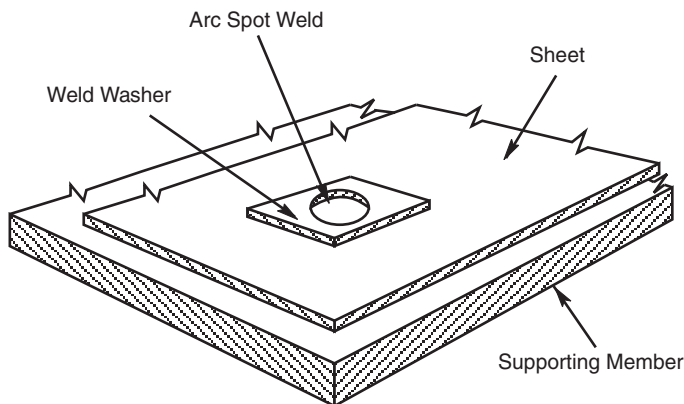

**Figure E2.2-1 Typical Weld Washer**

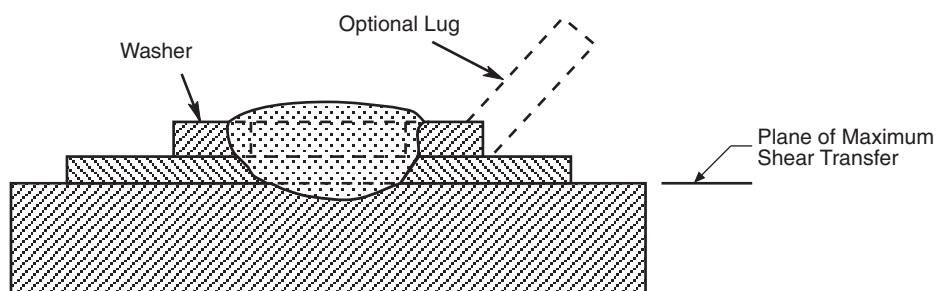

**Figure E2.2-2 Arc Spot Weld Using Washer**

### E2.2.1 Minimum Edge and End Distance

The distance from the centerline of an arc spot weld to the end or edge of the connected member shall not be less than  $1.5d$ . In no case shall the clear distance between welds and the end or edge of the member be less than  $1.0d$ . See Figures E2.2.1-1 and E2.2.1-2 for details.

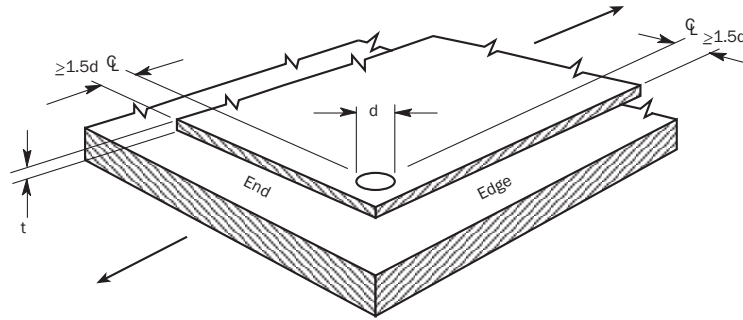

**Figure E2.2.1-1 End and Edge Distance for Arc Spot Welds – Single Sheet**

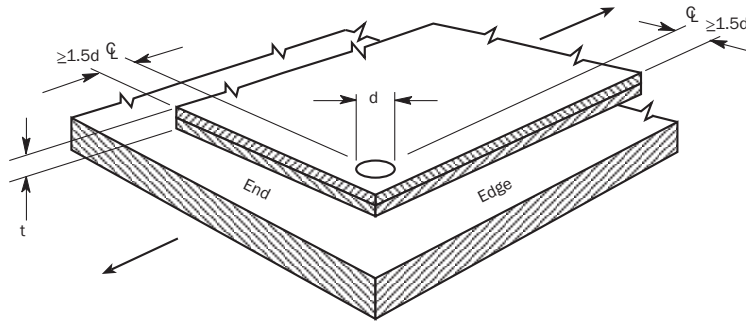

**Figure E2.2.1-2 End and Edge Distance for Arc Spot Welds – Double Sheet**

**E2.2.2 Shear**

**E2.2.2.1 Shear Strength [Resistance] for Sheet(s) Welded to a Thicker Supporting Member**

The *nominal shear strength [resistance]*,  $P_n$ , of each arc spot weld between the sheet or sheets and a thicker supporting member shall be determined by using the smaller of either (a) or (b). The corresponding *safety factor* and *resistance factors* shall be used to determine the *allowable strength* or *design strength [factored resistance]* in accordance with the applicable design method in Section A4, A5, or A6.

$$(a) P_n = \frac{\pi d_e^2}{4} 0.75 F_{xx} \tag{Eq. E2.2.2.1-1}$$

$$\Omega = 2.55 \quad (ASD)$$

$$\phi = 0.60 \quad (LRFD)$$

$$= 0.50 \quad (LSD)$$

$$(b) \text{ For } (d_a/t) \leq 0.815 \sqrt{E/F_u}$$

$$P_n = 2.20 t d_a F_u \tag{Eq. E2.2.2.1-2}$$

$$\Omega = 2.20 \quad (ASD)$$

$$\begin{aligned}\phi &= 0.70 \quad (\text{LRFD}) \\ &= 0.60 \quad (\text{LSD})\end{aligned}$$

$$\text{For } 0.815\sqrt{E/F_u} < (d_a/t) < 1.397\sqrt{E/F_u}$$

$$P_n = 0.280 \left[ 1 + 5.59 \frac{\sqrt{E/F_u}}{d_a/t} \right] t d_a F_u \quad (\text{Eq. E2.2.2.1-3})$$

$$\begin{aligned}\Omega &= 2.80 \quad (\text{ASD}) \\ \phi &= 0.55 \quad (\text{LRFD}) \\ &= 0.45 \quad (\text{LSD})\end{aligned}$$

$$\text{For } (d_a/t) \geq 1.397\sqrt{E/F_u}$$

$$P_n = 1.40 t d_a F_u \quad (\text{Eq. E2.2.2.1-4})$$

$$\begin{aligned}\Omega &= 3.05 \quad (\text{ASD}) \\ \phi &= 0.50 \quad (\text{LRFD}) \\ &= 0.40 \quad (\text{LSD})\end{aligned}$$

where

$P_n$  = Nominal shear strength [resistance] of arc spot weld

$d_e$  = Effective diameter of fused area at plane of maximum shear transfer

$$= 0.7d - 1.5t \leq 0.55d \quad (\text{Eq. E2.2.2.1-5})$$

where

$d$  = Visible diameter of outer surface of arc spot weld

$t$  = Total combined base steel *thickness* (exclusive of coatings) of sheets involved in shear transfer above plane of maximum shear transfer

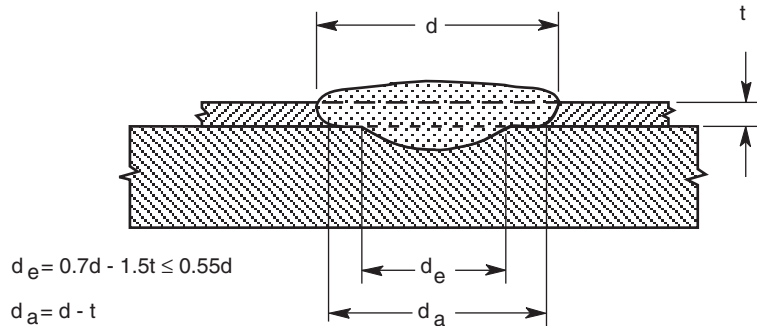

**Figure E2.2.2.1-1 Arc Spot Weld – Single Thickness of Sheet**

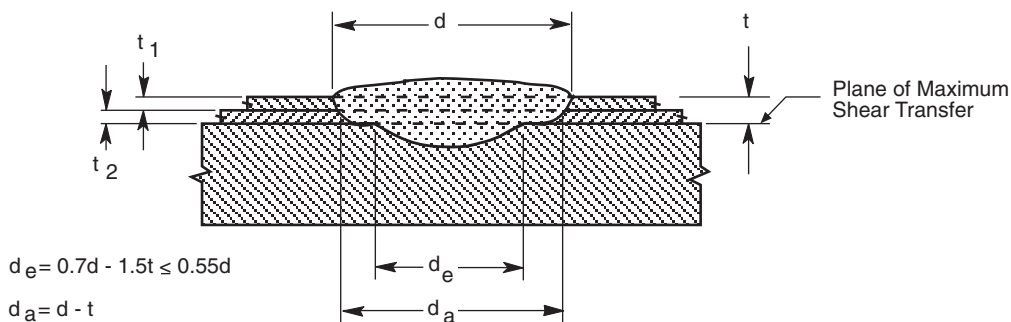

**Figure E2.2.2.1-2 Arc Spot Weld – Double Thickness of Sheet**

- $F_{xx}$  = Tensile strength of electrode classification  
 $d_a$  = Average diameter of arc spot weld at mid-thickness of  $t$  where  $d_a = (d - t)$  for single sheet or multiple sheets not more than four lapped sheets over a supporting member. See Figures E2.2.2.1-1 and E2.2.2.1-2 for diameter definitions.  
 $E$  = Modulus of elasticity of steel  
 $F_u$  = Tensile strength as determined in accordance with Section A2.1, A2.2, or A2.3.2

### E2.2.2.2 Shear Strength [Resistance] for Sheet-to-Sheet Connections

The *nominal shear strength [resistance]* for each weld between two sheets of equal *thickness* shall be determined in accordance with Eq. E2.2.2.2-1. The *safety factor* and *resistance factors* in this section shall be used to determine the *allowable strength* or *design strength [factored resistance]* in accordance with the applicable design method in Section A4, A5, or A6.

$$P_n = 1.65td_aF_u \quad (\text{Eq. E2.2.2.2-1})$$

$$\Omega = 2.20 \quad (\text{ASD})$$

$$\phi = 0.70 \quad (\text{LRFD})$$

$$= 0.60 \quad (\text{LSD})$$

where

$P_n$  = Nominal shear strength [resistance] of sheet-to-sheet *connection*

$t$  = Total combined base steel *thickness* (exclusive of coatings) of sheets involved in shear transfer above plane of maximum shear transfer

$d_a$  = Average diameter of arc spot weld at mid-thickness of  $t$ . See Figure E2.2.2.2-1 for diameter definitions.

$$= (d - t)$$

where

$d$  = Visible diameter of the outer surface of arc spot weld

$d_e$  = Effective diameter of fused area at plane of maximum shear transfer

$$= 0.7d - 1.5t \leq 0.55d \quad (\text{Eq. E2.2.2.2-2})$$

$F_u$  = Tensile strength of sheet as determined in accordance with Section A2.1 or A2.2

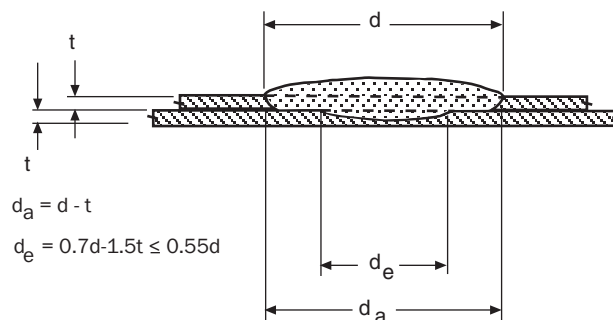

Figure E2.2.2.2-1 Arc Spot Weld – Sheet-to-Sheet

In addition, the following limits shall apply:

- (1)  $F_u \leq 59 \text{ ksi (407 MPa or 4150 kg/cm}^2\text{)}$ ,
- (2)  $F_{xx} > F_u$ , and
- (3)  $0.028 \text{ in. (0.71 mm)} \leq t \leq 0.0635 \text{ in. (1.61 mm)}$ .

### E2.2.3 Tension

The uplift *nominal tensile strength [resistance]*,  $P_n$ , of each concentrically loaded arc spot weld connecting sheets and supporting member shall be computed as the smaller of either Eq. E2.2.3-1 or Eq. E2.2.3-2 as follows. The *safety factor* and *resistance factors* shall be used to determine the *allowable strength* or *design strength [factored resistance]* in accordance with the applicable design method in Section A4, A5, or A6.

$$P_n = \frac{\pi d_e^2}{4} F_{xx} \quad (\text{Eq. E2.2.3-1})$$

$$P_n = 0.8(F_u/F_y)^2 t d_a F_u \quad (\text{Eq. E2.2.3-2})$$

For panel and deck applications:

$$\Omega = 2.50 \quad (\text{ASD})$$

$$\phi = 0.60 \quad (\text{LRFD})$$

$$= 0.50 \quad (\text{LSD})$$

For all other applications:

$$\Omega = 3.00 \quad (\text{ASD})$$

$$\phi = 0.50 \quad (\text{LRFD})$$

$$= 0.40 \quad (\text{LSD})$$

The following limits shall apply:

$$t d_a F_u \leq 3 \text{ kips (13.34 kN)},$$

$$F_{xx} \geq 60 \text{ ksi (410 MPa or 4220 kg/cm}^2\text{)},$$

$$F_u \leq 82 \text{ ksi (565 MPa or 5770 kg/cm}^2\text{) (of connecting sheets), and}$$

$$F_{xx} > F_u.$$

See Section E2.2.2 for definitions of variables.

For eccentrically loaded arc spot welds subjected to an uplift tension load, the nominal tensile strength [resistance] shall be taken as 50 percent of the above value.

For *connections* having multiple sheets, the strength [resistance] shall be determined by using the sum of the sheet *thicknesses* as given by Eq. E2.2.3-2.

At the side lap connection within a deck system, the nominal tensile strength [resistance] of the weld connection shall be 70 percent of the above values.

Where it is shown by measurement that a given weld procedure consistently gives a larger effective diameter,  $d_e$ , or average diameter,  $d_a$ , as applicable, this larger diameter shall be permitted to be used provided the particular welding procedure used for making those welds is followed.

### E2.2.4 Combined Shear and Tension on an Arc Spot Weld

For arc spot weld connections subjected to a combination of shear and tension, Section E2.2.4.1 or Section E2.2.4.2 shall be applied. In addition, the following limitations shall be



satisfied:

$$F_u \leq 105 \text{ ksi (724 MPa, 7380 kg/cm}^2\text{)}$$

$$F_{exx} \geq 60 \text{ ksi (414 MPa, 4220 kg/cm}^2\text{)}$$

$$t d_a F_u \leq 3 \text{ kips (13.34 kN, 1360 kg)}$$

$$F_u / F_y \geq 1.02$$

$$0.47 \text{ in. (11.9 mm)} \leq d \leq 1.02 \text{ in. (25.9 mm)}$$

#### E2.2.4.1 ASD Method

For arc spot weld connections subjected to a combination of shear and tension forces, the following requirements shall be met for ASD:

$$\text{If } \left( \frac{\Omega_t T}{P_{nt}} \right)^{1.5} \leq 0.15, \text{ no interaction check shall be required.}$$

$$\text{If } \left( \frac{\Omega_t T}{P_{nt}} \right)^{1.5} > 0.15,$$

$$\left( \frac{\Omega_s Q}{P_{ns}} \right)^{1.5} + \left( \frac{\Omega_t T}{P_{nt}} \right)^{1.5} \leq 1 \quad (\text{Eq. E2.2.4.1-1})$$

where

$\Omega_t$  = Corresponding *safety factor* for  $P_{nt}$  given by Section E2.2.3

$T$  = *Required allowable tensile strength* of connection

$P_{nt}$  = *Nominal tension strength* as given by Section E2.2.3

$\Omega_s$  = Corresponding *safety factor* for  $P_{ns}$  given by Section E2.2.2

$Q$  = *Required allowable shear strength* of connection

$P_{ns}$  = *Nominal shear strength* as given by Section E2.2.2

#### E2.2.4.2 LRFD and LSD Method

For arc spot weld connections subjected to a combination of shear and tension forces, the following requirements shall be met for LRFD or LSD:

$$\text{If } \left( \frac{\bar{T}}{\phi_t P_{nt}} \right)^{1.5} \leq 0.15, \text{ no interaction check shall be required.}$$

$$\text{If } \left( \frac{\bar{T}}{\phi_t P_{nt}} \right)^{1.5} > 0.15,$$

$$\left( \frac{\bar{Q}}{\phi_s P_{ns}} \right)^{1.5} + \left( \frac{\bar{T}}{\phi_t P_{nt}} \right)^{1.5} \leq 1 \quad (\text{Eq. E2.2.3.2-1})$$

where

$\bar{T}$  = *Required tensile strength [factored tension force]* of the connection

=  $T_u$  for LRFD

=  $T_f$  for LSD

- $\phi_t$  = Resistance factor corresponding to  $P_{nt}$  given in E2.2.3
- $P_{nt}$  = Nominal tension strength [resistance] as given by Section E2.2.3
- $P_{ns}$  = Nominal shear strength [resistance] as given by Section E2.2.2
- $\bar{Q}$  = Required shear strength [factored shear force] of the connection
  - =  $Q_u$  for LRFD
  - =  $Q_f$  for LSD
- $\phi_s$  = Resistance factor corresponding to  $P_{ns}$  given in E2.2.2

**E2.3 Arc Seam Welds**

Arc seam welds covered by this Specification shall apply only to the following joints: ➔ **B**

- (a) Sheet to thicker supporting member in the flat position (See Figure E2.3-1), and
- (b) Sheet to sheet in the horizontal or flat position.

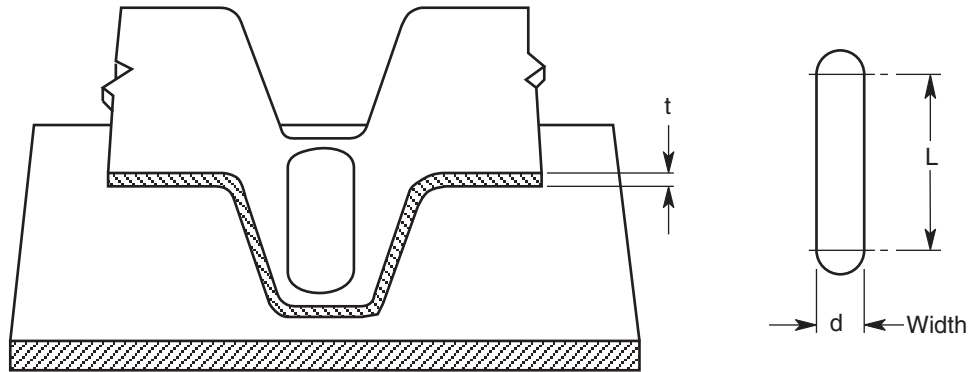

**Figure E2.3-1 Arc Seam Welds - Sheet to Supporting Member in Flat Position**

**E2.3.1 Minimum Edge and End Distance**

The distance from the centerline of an arc seam weld to the end or edge of the connected member shall not be less than  $1.5d$ . In no case shall the clear distance between welds and the end or edge of the member be less than  $1.0d$ . See Figure E2.3.1-1 for details.

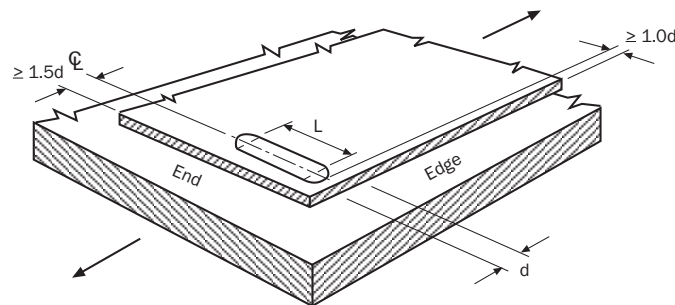

**Figure E2.3.1-1 End and Edge Distances for Arc Seam Welds**

**E2.3.2 Shear****E2.3.2.1 Shear Strength [Resistance] for Sheet(s) Welded to a Thicker Supporting Member**

The *nominal shear strength [resistance]*,  $P_n$ , of arc seam welds shall be determined by using the smaller of either Eq. E2.3.2.1-1 or Eq. E2.3.2.1-2. The *safety factor* and *resistance factors* in this section shall be used to determine the *allowable strength* or *design strength [factored resistance]* in accordance with the applicable design method in Section A4, A5, or A6.

$$P_n = \left[ \frac{\pi d_e^2}{4} + L d_e \right] 0.75 F_{xx} \quad (\text{Eq. E2.3.2.1-1})$$

$$P_n = 2.5 t F_u (0.25 L + 0.96 d_a) \quad (\text{Eq. E2.3.2.1-2})$$

$$\Omega = 2.55 \quad (\text{ASD})$$

$$\phi = 0.60 \quad (\text{LRFD})$$

$$= 0.50 \quad (\text{LSD})$$

where

$P_n$  = Nominal shear strength [resistance] of arc seam weld

$d_e$  = Effective width of seam weld at fused surfaces

$$= 0.7d - 1.5t$$

(Eq. E2.3.2.1-3)

where

$d$  = Width of arc seam weld

$L$  = Length of seam weld not including circular ends

(For computation purposes,  $L$  shall not exceed  $3d$ )

$d_a$  = Average width of seam weld

$$= (d - t) \text{ for single or double sheets}$$

(Eq. E2.3.2.1-4)

$F_u$ ,  $F_{xx}$ , and  $t$  = Values as defined in Section E2.2.2.1

**E2.3.2.2 Shear Strength [Resistance] for Sheet-to-Sheet Connections**

The *nominal shear strength [resistance]* for each weld between two sheets of equal *thickness* shall be determined in accordance with Eq. E2.3.2.2-1. The *safety factor* and *resistance factors* in this section shall be used to determine the *allowable strength* or *design strength [factored resistance]* in accordance with the applicable design method in Section A4, A5 or A6.

$$P_n = 1.65 t d_a F_u \quad (\text{Eq. E2.3.2.2-1})$$

$$\Omega = 2.20 \quad (\text{ASD})$$

$$\phi = 0.70 \quad (\text{LRFD})$$

$$= 0.60 \quad (\text{LSD})$$

where

$P_n$  = Nominal shear strength [resistance] of sheet-to-sheet *connection*

$d_a$  = Average width of arc seam weld at mid-thickness of  $t$ . See Figure E2.3.2.2-1 for width definitions.

$$= (d - t)$$

where

$d$  = Visible width of the outer surface of arc seam weld

$t$  = Total combined base steel thickness (exclusive of coatings) of sheets involved in shear transfer above plane of maximum shear transfer

$F_u$  = Tensile strength of sheet as determined in accordance with Section A2.1 or A2.2

In addition, the following limits shall apply:

- (1)  $F_u \leq 59 \text{ ksi}$  (407 MPa or 4150 kg/cm<sup>2</sup>)
- (2)  $F_{xx} > F_u$
- (3)  $0.028 \text{ in. (0.71 mm)} \leq t \leq 0.0635 \text{ in. (1.61 mm)}$

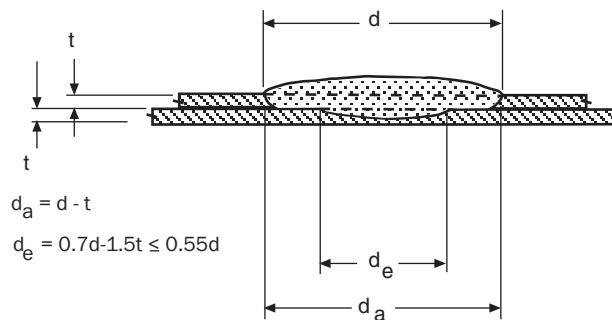

**Figure E2.3.2.2-1 Arc Seam Weld - Sheet-to-Sheet**

## E2.4 Fillet Welds

Fillet welds covered by this *Specification* shall apply to the welding of *joints* in any position, either:

- (a) Sheet to sheet, or
- (b) Sheet to thicker steel member.

The *nominal shear strength [resistance]*,  $P_n$ , of a fillet weld shall be determined in accordance with this section. The corresponding *safety factors* and *resistance factors* given in this section shall be used to determine the *allowable strength* or *design strength [factored resistance]* in accordance with the applicable design method in Section A4, A5, or A6.

- (1) For longitudinal loading:

For  $L/t < 25$

$$P_n = \left( 1 - \frac{0.01L}{t} \right) LtF_u \quad (\text{Eq. E2.4-1})$$

$$\Omega = 2.55 \quad (\text{ASD})$$

$$\phi = 0.60 \quad (\text{LRFD})$$

$$= 0.50 \quad (\text{LSD})$$

For  $L/t \geq 25$

$$P_n = 0.75 tL F_u \quad (\text{Eq. E2.4-2})$$

$$\Omega = 3.05 \quad (\text{ASD})$$

$$\phi = 0.50 \quad (\text{LRFD})$$

$$= 0.40 \quad (\text{LSD})$$

(2) For transverse loading:

$$P_n = tLF_u \quad (\text{Eq. E2.4-3})$$

$$\Omega = 2.35 \quad (\text{ASD})$$

$$\phi = 0.65 \quad (\text{LRFD})$$

$$= 0.60 \quad (\text{LSD})$$

where

$t$  = Least value of  $t_1$  or  $t_2$ , as shown in Figures E2.4-1 and E2.4-2

In addition, for  $t > 0.10$  in. (2.54 mm), the *nominal strength [resistance]* determined in accordance with (1) and (2) shall not exceed the following value of  $P_n$ :

$$P_n = 0.75 t_w LF_{xx} \quad (\text{Eq. E2.4-4})$$

$$\Omega = 2.55 \quad (\text{ASD})$$

$$\phi = 0.60 \quad (\text{LRFD})$$

$$= 0.50 \quad (\text{LSD})$$

where

$P_n$  = Nominal fillet weld strength [resistance]

$L$  = Length of fillet weld

$F_u$  and  $F_{xx}$  = Values as defined in Section E2.2.2.1

$t_w$  = Effective throat

=  $0.707 w_1$  or  $0.707 w_2$ , whichever is smaller. A larger effective throat is permitted if measurement shows that the welding procedure to be used consistently yields a larger value of  $t_w$ .

where

$w_1$  and  $w_2$  = leg of weld (see Figures E2.4-1 and E2.4-2) and  $w_1 \leq t_1$  in lap joints

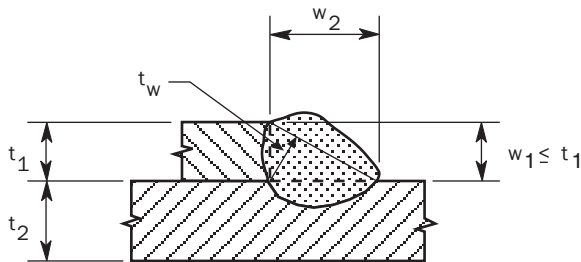

Figure E2.4-1 Fillet Welds - Lap Joint

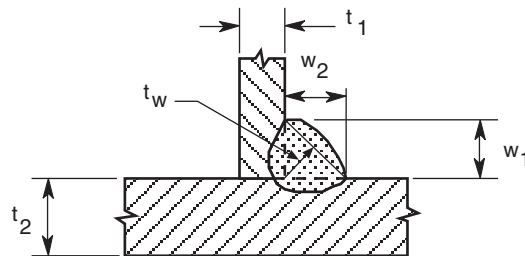

Figure E2.4-2 Fillet Welds - T Joint

## E2.5 Flare Groove Welds

Flare groove welds covered by this *Specification* shall apply to welding of *joints* in any position, either sheet to sheet for flare-V groove welds, sheet to sheet for flare-bevel groove welds, or sheet to thicker steel member for flare-bevel groove welds.

The *nominal shear strength [resistance]*,  $P_{nv}$ , of a flare groove weld shall be determined in accordance with this section. The corresponding *safety factors* and *resistance factors* given in this section shall be used to determine the *allowable strength* or *design strength [factored resistance]* in accordance with the applicable design method in Section A4, A5, or A6.

Larger effective throat thicknesses,  $t_w$ , than those determined by Equation E2.5-5 or Equation E2.5-7, as appropriate, shall be permitted, provided the fabricator can establish by

qualification the consistent production of such larger effective throat thicknesses. Qualification shall consist of sectioning the weld normal to its axis, at mid-length and terminal ends. Such sectioning shall be made on a number of combinations of material sizes representative of the range to be used in the fabrication.

(a) For flare-bevel groove welds, transverse loading (see Figure E2.5-1):

$$\begin{aligned}
 P_n &= 0.833tLF_u && (Eq. E2.5-1) \\
 \Omega &= 2.55 \quad (ASD) \\
 \phi &= 0.60 \quad (LRFD) \\
 &= 0.50 \quad (LSD)
 \end{aligned}$$

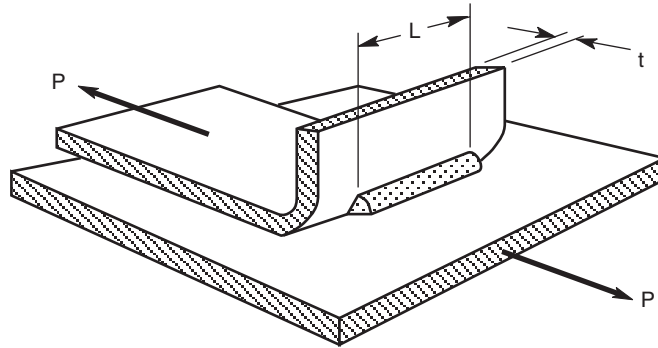

Figure E2.5-1 Flare-Bevel Groove Weld

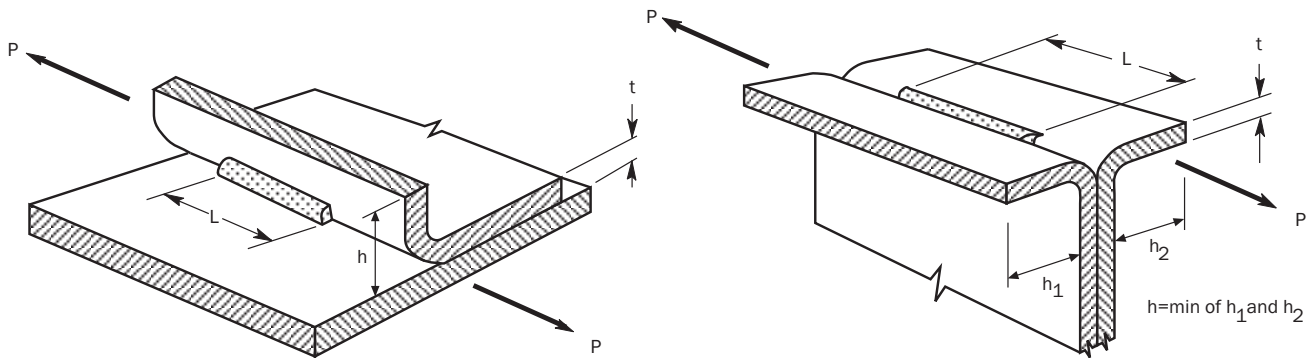

Figure E2.5-2 Shear in Flare Bevel Groove Weld    Figure E2.5-3 Shear in Flare V-Groove Weld

(b) For flare groove welds, longitudinal loading (see Figures E2.5-2 and E2.5-3):

(1) For  $t \leq t_w < 2t$  or if the lip height,  $h$ , is less than weld length,  $L$ :

$$\begin{aligned}
 P_n &= 0.75tLF_u && (Eq. E2.5-2) \\
 \Omega &= 2.80 \quad (ASD) \\
 \phi &= 0.55 \quad (LRFD) \\
 &= 0.45 \quad (LSD)
 \end{aligned}$$

(2) For  $t_w \geq 2t$  with the lip height,  $h$ , equal to or greater than weld length,  $L$ :

$$\begin{aligned}
 P_n &= 1.50tLF_u && (Eq. E2.5-3) \\
 \Omega &= 2.80 \quad (ASD) \\
 \phi &= 0.55 \quad (LRFD) \\
 &= 0.45 \quad (LSD)
 \end{aligned}$$

(c) For  $t > 0.10$  in. (2.54 mm), the *nominal strength [resistance]* determined in accordance with (a) or (b) shall not exceed the value of  $P_n$  calculated in accordance with Eq. E2.5-4.

$$P_n = 0.75t_w L F_{xx} \quad (Eq. E2.5-4)$$

$$\Omega = 2.55 \quad (\text{ASD})$$

$$\phi = 0.60 \quad (\text{LRFD})$$

$$= 0.50 \quad (\text{LSD})$$

where

$P_n$  = Nominal flare groove weld strength [resistance]

$t$  = Thickness of welded member as defined in Figures E2.5-1 to E2.5-3

$L$  = Length of weld

$F_u$  and  $F_{xx}$  = Values as defined in Section E2.2.2.1

$h$  = Height of lip

$t_w$  = Effective throat of flare groove weld determined using the following equations.

(i) For a flare-bevel groove weld

$$t_w = \left[ w_2 + t_{wf} - R + \sqrt{2Rw_1 - w_1^2} \right] \left( \frac{w_1}{w_f} \right) - R \eta \left( \frac{w_2}{w_f} \right) \quad (Eq. E2.5-5)$$

where

$w_1, w_2$  = Leg of weld (see Figure E2.5-4)

$t_{wf}$  = Effective throat of groove weld that is filled flush to the surface,  $w_1 = R$ , determined in accordance with Table E2.5-1

$R$  = Radius of outside bend surface

$\eta$  =  $[1 - \cos(\text{equivalent angle})]$  determined in accordance with Table E2.5-1

$w_f$  = Face width of weld

$$= \sqrt{w_1^2 + w_2^2} \quad (Eq. E2.5-6)$$

**Table E2.5-1  
Flare Bevel Groove Welds**

Welding Process	Throat Depth ( $t_{wf}$ )	$\eta$
SMAW, FCAW-S	5/16 R	0.274
GMAW, FCAW-G	5/8 R	0.073
SAW	5/16 R	0.274

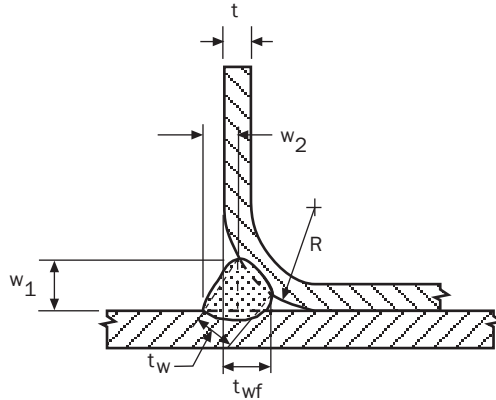

**Figure E2.5-4 Flare Bevel Groove Weld**

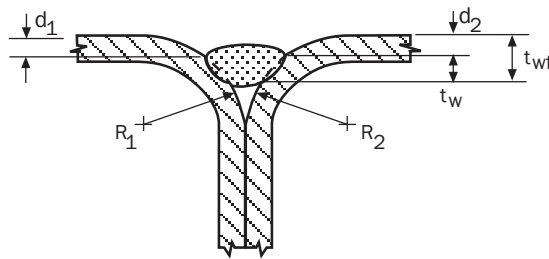

**Figure E2.5-5 Flare V-Groove Weld**

(ii) For a flare V-groove weld

$$t_w = \text{smaller of } (t_{wf} - d_1) \text{ and } (t_{wf} - d_2) \quad (Eq. E2.5-7)$$

where

$d_1$  and  $d_2$  = Weld offset from flush condition (see Figure E2.5-5)

$t_{wf}$  = Effective throat of groove weld that is filled flush to the surface (i.e.  $d_1 = d_2 = 0$ ), determined in accordance with Table E2.5-2

$R_1$  and  $R_2$  = Radius of outside bend surface as defined in Figure E2.5-5

**Table E2.5-2  
Flare V-Groove Welds**

Welding Process	Throat Depth ( $t_{wf}$ )
SMAW, FCAW-S	5/8 R
GMAW, FCAW-G	3/4 R
SAW	1/2 R
Note: R shall be the lesser of $R_1$ and $R_2$	



## E2.6 Resistance Welds

The *nominal shear strength [resistance]*,  $P_n$ , of spot welds shall be determined in accordance with this section. The *safety factor* and *resistance factors* given in this section shall be used to determine the *allowable strength* or *design strength [factored resistance]* in accordance with the applicable design method in Section A4, A5, or A6.

$$\Omega = 2.35 \quad (ASD)$$

$$\phi = 0.65 \quad (LRFD)$$

$$= 0.55 \quad (LSD)$$

When  $t$  is in inches and  $P_n$  is in kips:

For  $0.01 \text{ in.} \leq t < 0.14 \text{ in.}$

$$P_n = 144t^{1.47} \quad (Eq. E2.6-1)$$

For  $0.14 \text{ in.} \leq t \leq 0.18 \text{ in.}$

$$P_n = 43.4t + 1.93 \quad (Eq. E2.6-2)$$

When  $t$  is in millimeters and  $P_n$  is in kN:

For  $0.25 \text{ mm} \leq t < 3.56 \text{ mm}$

$$P_n = 5.51t^{1.47} \quad (Eq. E2.6-3)$$

For  $3.56 \text{ mm} \leq t \leq 4.57 \text{ mm}$

$$P_n = 7.6t + 8.57 \quad (Eq. E2.6-4)$$

When  $t$  is in centimeters and  $P_n$  is in kg:

For  $0.025 \text{ cm} \leq t < 0.356 \text{ cm}$

$$P_n = 16600t^{1.47} \quad (Eq. E2.6-5)$$

For  $0.356 \text{ cm} \leq t \leq 0.457 \text{ cm}$

$$P_n = 7750t + 875 \quad (Eq. E2.6-6)$$

where

$P_n$  = Nominal resistance weld strength [resistance]

$t$  = Thickness of thinnest outside sheet

## E3 Bolted Connections

The following design criteria and the requirements stipulated in Section E3a of Appendices A and B shall apply to bolted *connections* used for *cold-formed steel structural members* in which the *thickness* of the thinnest connected part is 3/16 in. (4.76 mm) or less. For bolted connections in which the thickness of the thinnest connected part is greater than 3/16 in. (4.76 mm), the specifications and standards stipulated in Section E3a of Appendix A or B shall apply.  **A,B**

Bolts, nuts, and washers conforming to one of the following ASTM specifications shall be approved for use under this *Specification*:

ASTM A194/A194M, Carbon and Alloy Steel Nuts for Bolts for High-Pressure and High-Temperature Service

ASTM A307 (Type A), Carbon Steel Bolts and Studs, 60,000 PSI Tensile Strength

ASTM A325, Structural Bolts, Steel, Heat Treated, 120/105 ksi Minimum Tensile Strength

ASTM A325M, High Strength Bolts for Structural Steel Joints [Metric]

ASTM A354 (Grade BD), Quenched and Tempered Alloy Steel Bolts, Studs, and Other Externally Threaded Fasteners (for diameter of bolt smaller than 1/2 in.)

ASTM A449, Quenched and Tempered Steel Bolts and Studs (for diameter of bolt smaller than 1/2 in.)

ASTM A490, Heat-Treated Steel Structural Bolts, 150 ksi Minimum Tensile Strength

ASTM A490M, High Strength Steel Bolts, Classes 10.9 and 10.9.3, for Structural Steel Joints [Metric]

ASTM A563, Carbon and Alloy Steel Nuts

ASTM A563M, Carbon and Alloy Steel Nuts [Metric]

ASTM F436, Hardened Steel Washers

ASTM F436M, Hardened Steel Washers [Metric]

ASTM F844, Washers, Steel, Plain (Flat), Unhardened for General Use

ASTM F959, Compressible Washer-Type Direct Tension Indicators for Use with Structural Fasteners

ASTM F959M, Compressible Washer-Type Direct Tension Indicators for Use with Structural Fasteners [Metric]

When other than the above are used, drawings shall indicate clearly the type and size of fasteners to be employed and the *nominal strength* [resistance] assumed in design.

Bolts shall be installed and tightened to achieve satisfactory performance of the connections.

Slotted or oversize holes shall be permitted to be used when the hole occurs within the lap of lapped or nested Z-members, subject to the following restrictions:

- (1) 1/2 in. (12.7 mm) diameter bolts only with or without washers or backup plates,
- (2) Maximum slot size is 9/16 in. x 7/8 in. (14.3 mm x 22.2 mm) slotted vertically,
- (3) Maximum oversize hole is 5/8 in. (15.9 mm) diameter,
- (4) Minimum member thickness is 0.060 in. (1.52 mm) nominal,
- (5) Maximum member *yield stress* is 60 ksi (410 MPa, and 4220 kg/cm<sup>2</sup>),
- (6) Minimum lap length measured from center of frame to end of lap is 1.5 times the member depth.

### **E3.1 Minimum Spacing**

The distance between the centers of fasteners shall not be less than 3d. In addition, the minimum distance between centers of bolt holes shall provide clearance for bolt heads, nuts, washers and the wrench. For oversized and slotted holes, the clear distance between edges of two adjacent holes shall not be less than 2d.

### **E3.2 Minimum Edge and End Distances**

The distance from the center of a fastener to the edge or end of any part shall not be less than 1.5d. For oversized and slotted holes, the distance between the edge of the hole and the edge or end of the member shall not be less than d.

### E3.3 Bearing

The *available bearing strength* [*factored resistance*] of bolted *connections* shall be determined in accordance with Sections E3.3.1 and E3.3.2. For conditions not shown, the available bearing strength [*factored resistance*] of bolted connections shall be determined by tests. 

#### E3.3.1 Bearing Strength [Resistance] without Consideration of Bolt Hole Deformation

When deformation around the bolt holes is not a design consideration, the *nominal bearing strength* [*resistance*],  $P_n$ , of the connected sheet for each loaded bolt shall be determined in accordance with Eq. E3.3.1-1. The *safety factor* and *resistance factors* given in this section shall be used to determine the *allowable strength* or *design strength* [*factored resistance*] in accordance with the applicable design method in Section A4, A5, or A6.

$$P_n = C m_f d t F_u \quad (\text{Eq. E3.3.1-1})$$

$$\Omega = 2.50 \quad (\text{ASD})$$

$$\phi = 0.60 \quad (\text{LRFD})$$

$$= 0.50 \quad (\text{LSD})$$

where

$C$  = Bearing factor, determined in accordance with Table E3.3.1-1

$m_f$  = Modification factor for type of bearing *connection*, which shall be determined according to Table E3.3.1-2

$d$  = Nominal bolt diameter

$t$  = Uncoated sheet *thickness*

$F_u$  = *Tensile strength* of sheet as defined in Section A2.1 or A2.2

**Table E3.3.1-1**  
**Bearing Factor, C**

Thickness of Connected Part, $t$ , in. (mm)	Ratio of Fastener Diameter to Member Thickness, $d/t$	C
$0.024 \leq t < 0.1875$ ( $0.61 \leq t < 4.76$ )	$d/t < 10$	3.0
	$10 \leq d/t \leq 22$	$4 - 0.1(d/t)$
	$d/t > 22$	1.8

**Table E3.3.1-2**  
**Modification Factor,  $m_f$ , for Type of Bearing Connection**

Type of Bearing Connection	$m_f$
Single Shear and Outside Sheets of Double Shear Connection with Washers under Both Bolt Head and Nut	1.00
Single Shear and Outside Sheets of Double Shear Connection without Washers under Both Bolt Head and Nut, or with only One Washer	0.75
Inside Sheet of Double Shear Connection with or without Washers	1.33

### E3.3.2 Bearing Strength [Resistance] with Consideration of Bolt Hole Deformation

When deformation around a bolt hole is a design consideration, the *nominal bearing strength [resistance]*,  $P_n$ , shall be calculated in accordance with Eq. E3.3.2-1. The *safety factor* and *resistance factors* given in this section shall be used to determine the *available strength [factored resistance]* in accordance with the applicable design method in Section A4, A5, or A6. In addition, the *available strength* shall not exceed the available strength obtained in accordance with Section E3.3.1.

$$P_n = (4.64\alpha t + 1.53)dtF_u \quad (\text{Eq. E3.3.2-1})$$

$$\Omega = 2.22 \quad (\text{ASD})$$

$$\phi = 0.65 \quad (\text{LRFD})$$

$$= 0.55 \quad (\text{LSD})$$

where

$\alpha$  = Coefficient for conversion of units

= 1 for US customary units (with  $t$  in inches)

= 0.0394 for SI units (with  $t$  in mm)

= 0.394 for MKS units (with  $t$  in cm)

See Section E3.3.1 for definitions of other variables.

### E3.4 Shear and Tension in Bolts

See Section E3.4 of the Appendix A or B for provisions provided in this section. 

### E4 Screw Connections

All E4 requirements shall apply to screws with  $0.08 \text{ in. (2.03 mm)} \leq d \leq 0.25 \text{ in. (6.35 mm)}$ . The screws shall be thread-forming or thread-cutting, with or without a self-drilling point. Screws shall be installed and tightened in accordance with the manufacturer's recommendations.

The *nominal screw connection strengths [resistances]* shall also be limited by Section C2.

For *diaphragm* applications, Section D5 shall be used.

Except where otherwise indicated, the following *safety factor* or *resistance factor* shall be used to determine the *allowable strength* or *design strength [factored resistance]* in accordance with the applicable design method in Section A4, A5, or A6.

$$\Omega = 3.00 \quad (\text{ASD})$$

$$\phi = 0.50 \quad (\text{LRFD})$$

$$= 0.40 \quad (\text{LSD})$$

Alternatively, design values for a particular application shall be permitted to be based on tests, with the safety factor,  $\Omega$ , and the resistance factor,  $\phi$ , determined according to Chapter F.

The following notation shall apply to Section E4:

$d$  = Nominal screw diameter

$d_h$  = Screw head diameter or hex washer head integral washer diameter

$d_w$  = Steel washer diameter

$d'_w$  = Effective pull-over resistance diameter

- $P_{ns}$  = Nominal shear strength [resistance] per screw  
 $P_{ss}$  = Nominal shear strength [resistance] of screw as reported by manufacturer or determined by independent laboratory testing  
 $P_{not}$  = Nominal pull-out strength [resistance] per screw  
 $P_{nov}$  = Nominal pull-over strength [resistance] per screw  
 $P_{ts}$  = Nominal tension strength [resistance] of screw as reported by manufacturer or determined by independent laboratory testing  
 $t_1$  = Thickness of member in contact with screw head or washer  
 $t_2$  = Thickness of member not in contact with screw head or washer  
 $t_c$  = Lesser of depth of penetration and thickness  $t_2$   
 $F_{u1}$  = Tensile strength of member in contact with screw head or washer  
 $F_{u2}$  = Tensile strength of member not in contact with screw head or washer

#### E4.1 Minimum Spacing

The distance between the centers of fasteners shall not be less than  $3d$ .

#### E4.2 Minimum Edge and End Distances

The distance from the center of a fastener to the edge or end of any part shall not be less than  $1.5d$ .

#### E4.3 Shear

##### E4.3.1 Shear Strength [Resistance] Limited by Tilting and Bearing

The nominal shear strength [resistance] per screw,  $P_{ns}$ , shall be determined in accordance with this section.

For  $t_2/t_1 \leq 1.0$ ,  $P_{ns}$  shall be taken as the smallest of

$$P_{ns} = 4.2 (t_2^3 d)^{1/2} F_{u2} \quad (\text{Eq. E4.3.1-1})$$

$$P_{ns} = 2.7 t_1 d F_{u1} \quad (\text{Eq. E4.3.1-2})$$

$$P_{ns} = 2.7 t_2 d F_{u2} \quad (\text{Eq. E4.3.1-3})$$

For  $t_2/t_1 \geq 2.5$ ,  $P_{ns}$  shall be taken as the smaller of

$$P_{ns} = 2.7 t_1 d F_{u1} \quad (\text{Eq. E4.3.1-4})$$

$$P_{ns} = 2.7 t_2 d F_{u2} \quad (\text{Eq. E4.3.1-5})$$

For  $1.0 < t_2/t_1 < 2.5$ ,  $P_{ns}$  shall be calculated by linear interpolation between the above two cases.

##### E4.3.2 Shear in Screws

The nominal shear strength [resistance] of the screw shall be taken as  $P_{ss}$ .

In lieu of the value provided in Section E4, the safety factor or the resistance factor shall be permitted to be determined in accordance with Section F1 and shall be taken as  $1.25\Omega \leq 3.0$  (ASD),  $\phi/1.25 \geq 0.5$  (LRFD), or  $\phi/1.25 \geq 0.4$  (LSD).

## E4.4 Tension

For screws that carry tension, the head of the screw or washer, if a washer is provided, shall have a diameter  $d_h$  or  $d_w$  not less than 5/16 in. (7.94 mm). The nominal washer *thickness* shall be at least 0.050 in. (1.27 mm) for  $t_1$  greater than 0.027 in. (0.69 mm) and at least 0.024 in. (0.61 mm) for  $t_1$  equal to or less than 0.027 in. (0.69 mm).

### E4.4.1 Pull-Out Strength [Resistance]

The *nominal pull-out strength [resistance]*,  $P_{not}$ , shall be calculated as follows:

$$P_{not} = 0.85 t_c d F_{u2} \quad (Eq. E4.4.1-1)$$

### E4.4.2 Pull-Over Strength [Resistance]

The *nominal pull-over strength [resistance]*,  $P_{nov}$ , shall be calculated as follows:

$$P_{nov} = 1.5t_1d'_w F_{u1} \quad (Eq. E4.4.2-1)$$

where

$d'_w$  = Effective pull-over diameter determined in accordance with (a), (b), or (c) as follows:

- (a) For a round head, a hex head (Figure E4.4.2(1)), pancake screw washer head (Figure E4.4.2(2)), or hex washer head (Figure E4.4.2(3)) screw with an independent and solid steel washer beneath the screw head:

$$d'_w = d_h + 2t_w + t_1 \leq d_w \quad (Eq. E4.4.2-2)$$

where

$d_h$  = Screw head diameter or hex washer head integral washer diameter

$t_w$  = Steel washer *thickness*

$d_w$  = Steel washer diameter

- (b) For a round head, a hex head, or hex washer head screw without an independent washer beneath the screw head:

$$d'_w = d_h \text{ but not larger than } 1/2 \text{ in. (12.7 mm)}$$

- (c) For a domed (non-solid and either independent or integral) washer beneath the screw head (Figure E4.4.2(4)), it shall be permissible to use  $d'_w$  as calculated in Eq. E4.4.2-2, with  $d_h$ ,  $t_w$ , and  $t_1$  as defined in Figure E4.4.2(4). In the equation,  $d'_w$  can not exceed 5/8 in. (16 mm).

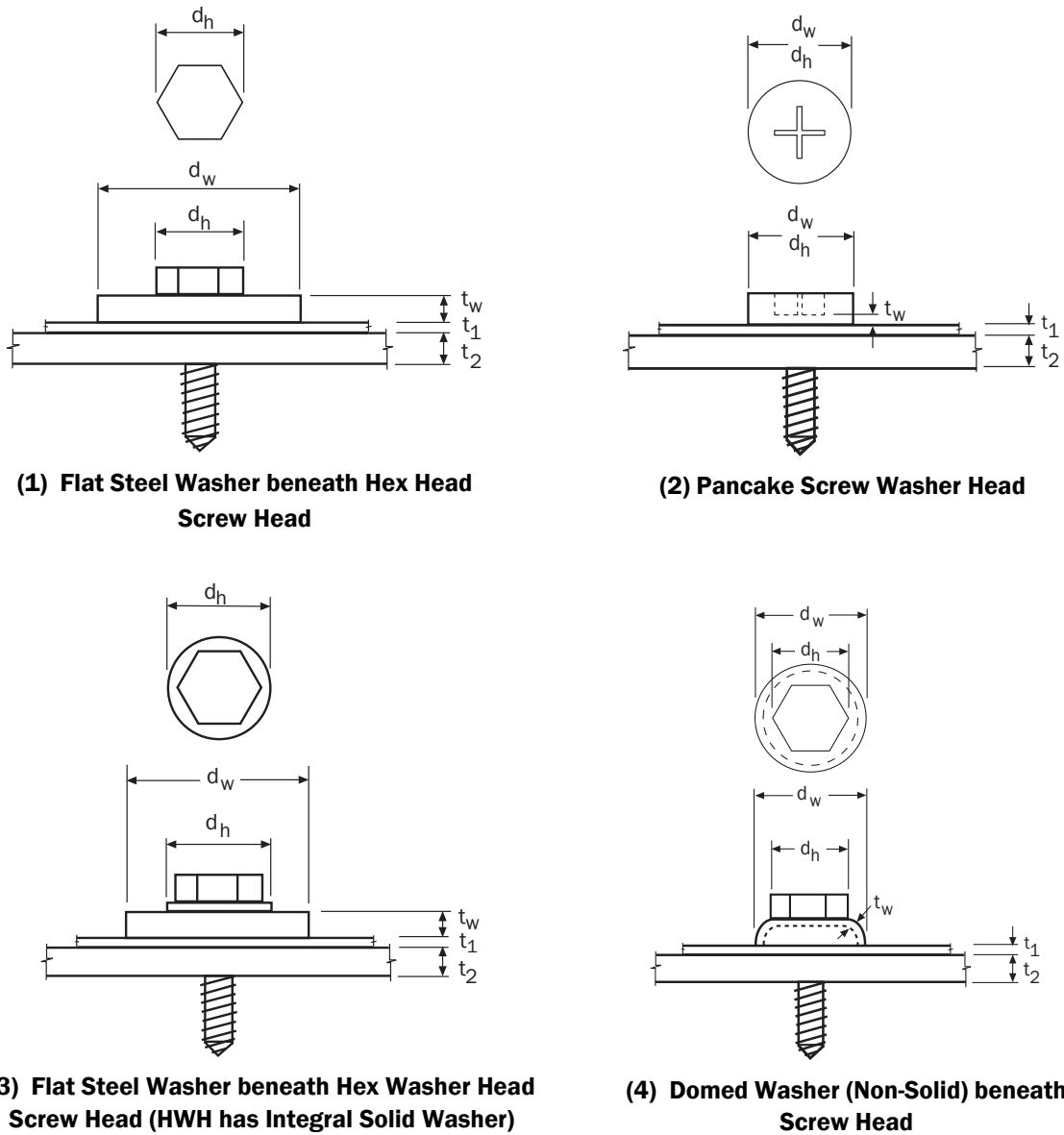

Figure E4.4.2 Screw Pull-Over with Washer

### E4.4.3 Tension in Screws

The *nominal tension strength [resistance]* of the screw shall be taken as  $P_{ts}$ .

In lieu of the value provided in Section E4, the *safety factor* or the *resistance factor* shall be permitted to be determined in accordance with Section F1 and shall be taken as  $1.25\Omega \leq 3.0$  (ASD),  $\phi/1.25 \geq 0.5$  (LRFD), or  $\phi/1.25 \geq 0.4$  (LSD).

## E4.5 Combined Shear and Pull-Over

### E4.5.1 ASD Method

For screw *connections* subjected to a combination of shear and tension forces, the following requirement shall be met:

$$\frac{Q}{P_{ns}} + 0.71 \frac{T}{P_{nov}} \leq \frac{1.10}{\Omega} \quad (\text{Eq. E4.5.1-1})$$

In addition,  $Q$  and  $T$  shall not exceed the corresponding *allowable strength* determined by Sections E4.3 and E4.4, respectively.

where

$Q$  = Required allowable shear strength of connection

$T$  = Required allowable tension strength of connection

$P_{ns}$  = Nominal shear strength of connection

$$= 2.7t_1dF_{u1}$$

(Eq. E4.5.1-2)

$P_{nov}$  = Nominal pull-over strength of connection

$$= 1.5t_1d_wF_{u1}$$

(Eq. E4.5.1-3)

where

$d_w$  = Larger of screw head diameter or washer diameter

$\Omega$  = 2.35

Eq. E4.5.1-1 shall be valid for connections that meet the following limits:

- (1)  $0.0285 \text{ in. (0.724 mm)} \leq t_1 \leq 0.0445 \text{ in. (1.130 mm)}$ ,
- (2) No. 12 and No. 14 self-drilling screws with or without washers,
- (3)  $d_w \leq 0.75 \text{ in. (19.1 mm)}$ ,
- (4)  $F_{u1} \leq 70 \text{ ksi (483 MPa or 4920 kg/cm}^2\text{)}$ , and
- (5)  $t_2/t_1 \geq 2.5$ .

For eccentrically loaded connections that produce a non-uniform pull-over force on the fastener, the nominal pull-over strength shall be taken as 50 percent of  $P_{nov}$ .

### E4.5.2 LRFD and LSD Methods

For screw *connections* subjected to a combination of shear and tension forces, the following requirements shall be met:

$$\frac{\bar{Q}}{P_{ns}} + 0.71 \frac{\bar{T}}{P_{nov}} \leq 1.10\phi \quad (\text{Eq. E4.5.2-1})$$

In addition,  $\bar{Q}$  and  $\bar{T}$  shall not exceed the corresponding *design strength [factored resistance]* determined in accordance with Sections E4.3 and E4.4, respectively.

where

$\bar{Q}$  = Required shear strength [factored shear force] of connection

=  $V_u$  for LRFD

=  $V_f$  for LSD

$\bar{T}$  = Required tension strength [factored tensile force] of connection

=  $T_u$  for LRFD



=  $T_f$  for LSD

$$P_{ns} = \text{Nominal shear strength [resistance] of connection} \\ = 2.7t_1dF_{u1} \quad (\text{Eq. E4.5.2-2})$$

$$P_{nov} = \text{Nominal pull-over strength [resistance] of connection} \\ = 1.5t_1d_wF_{u1} \quad (\text{Eq. E4.5.2-3})$$

where

$d_w$  = Larger of screw head diameter or washer diameter

$\phi$  = 0.65 (LRFD)

= 0.55 (LSD)

Eq. E4.5.2-1 shall be valid for connections that meet the following limits:

- (1)  $0.0285 \text{ in. (0.724 mm)} \leq t_1 \leq 0.0445 \text{ in. (1.13 mm)}$ ,
- (2) No. 12 and No. 14 self-drilling screws with or without washers,
- (3)  $d_w \leq 0.75 \text{ in. (19.1 mm)}$ ,
- (4)  $F_{u1} \leq 70 \text{ ksi (483 MPa or 4920 kg/cm}^2\text{)}$ , and
- (5)  $t_2/t_1 \geq 2.5$ .

For eccentrically loaded connections that produce a non-uniform pull-over force on the fastener, the nominal pull-over strength [resistance] shall be taken as 50 percent of  $P_{nov}$ .

## E5 Rupture

The design criteria of this section shall apply where the *thickness* of the thinnest connected part is 3/16 in. (4.76 mm) or less. For *connections* where the thickness of the thinnest connected part is greater than 3/16 in. (4.76 mm) the specifications and standards stipulated in Section E5a of Appendix A or B shall apply. ↔ **A****B**

For connection types utilizing welds or bolts, the nominal rupture strength [resistance],  $R_{nv}$  shall be the smallest of the values obtained in accordance with Sections E5.1, E5.2, and E5.3, as applicable. For connection types utilizing screws, the nominal rupture strength [resistance],  $R_{nv}$  shall be the lesser of the values obtained in accordance with Sections E5.1 and E5.2, as applicable. The corresponding *safety factor* and *resistance factors* given in Table E5-1 shall be used to determine the *allowable strength* or *design strength [factored resistance]* in accordance with the applicable design method in Section A4, A5 or A6. ↔ **B**

**Table E5-1**  
**Safety Factors and Resistance Factors for Rupture**

Connection Type	$\Omega$ (ASD)	$\phi$ (LRFD)	$\phi_u$ (LSD)
Welds	2.50	0.60	0.75
Bolts	2.22	0.65	0.75
Screws	3.00	0.50	0.75

### E5.1 Shear Rupture

The *nominal shear strength [resistance]*,  $V_n$  shall be calculated in accordance with Eq. E5.1-1.

$$V_n = 0.6 F_u A_{nv} \quad (\text{Eq. E5.1-1})$$

where

$F_u$  = Tensile strength of connected part as specified in Section A2.1 or A2.2

$A_{NV}$  = Net area subject to shear (parallel to force):

For a connection where each individual fastener pulls through the material towards the limiting edge individually:

$$A_{NV} = 2n t e_{net} \quad (Eq. E5.1-2)$$

where

$n$  = Number of fasteners on critical cross-section

$t$  = Base steel thickness of section

$e_{net}$  = Clear distance between end of material and edge of fastener hole or weld.

For a beam-end connection where one or more of the flanges are coped:

$$A_{NV} = (h_{wc} - n_b d_h) t \quad (Eq. E5.1-3)$$

where

$h_{wc}$  = Coped flat web depth

$n_b$  = Number of fasteners along failure path being analyzed

$d_h$  = Hole diameter

$t$  = Thickness of coped web

## E5.2 Tension Rupture

The nominal tensile rupture strength [resistance],  $T_n$ , shall be calculated in accordance with Eq. E5.2-1.

$$T_n = F_u A_e \quad (Eq. E5.2-1)$$

where

$A_e$  = Effective net area subject to tension

$$= U_{sl} U_{st} A_{nt} \quad (Eq. E5.2-2)$$

where

$U_{sl}$  = Shear lag factor determined in Table E5.2-1.

$U_{st}$  = Staggered connectors factor

= 1.0 where staggered connectors are not present

= 0.9 where staggered connectors are present

$A_{nt}$  = Net area subject to tension except as noted in Table E5.2-1 (perpendicular to force)

$$= A_g - n_b d_h t + (\Sigma s'^2 / 4g) t \quad (Eq. E5.2-3)$$

where

$A_g$  = Gross area of member

$s'$  = Longitudinal center-to-center spacing of any two consecutive holes

$g$  = Transverse center-to-center spacing between fastener gage lines

$n_b$  = Number of fasteners along failure path being analyzed

$d_h$  = Diameter of a standard hole

$t$  = Base steel thickness of section

$F_u$  = Tensile strength of connected part as specified in Section A2.1 or A2.2

The variables in Table E5.2-1 shall be defined as follows:

$\bar{x}$  = Distance from shear plane to centroid of cross section

L = Length of longitudinal weld or length of connection

s = Sheet width divided by number of bolt holes in cross section being analyzed

d = Nominal bolt diameter

**Table E5.2-1**  
**Shear Lag Factors for Connections**  
**to Tension Members**

Description of Element	Shear Lag Factor, $U_{sl}$
(1) For flat sheet <i>connections</i> not having staggered hole patterns	
(a) For multiple connectors in the line parallel to the force	$U_{sl} = 1.0$
(b) For a single connector, or a single row of connectors perpendicular to the force	
(i) For single shear and outside sheets of double shear connections with washers provided under the bolt head and the nut.	$U_{sl} = 3.33 d/s \leq 1.0$ (Eq. E5.2-4)
(ii) For single shear and outside sheets of double shear connections when washers are not provided or only one washer is provided under either the bolt head or the nut.	$U_{sl} = 2.5 d/s \leq 1.0$ (Eq. E5.2-5)
(iii) For inside sheets of double shear connections with or without washers.	$U_{sl} = 4.15 d/s \leq 1.0$ (Eq. E5.2-6)
(2) For flat sheet <i>connections</i> having staggered hole patterns	$U_{sl} = 1.0$
(3) For other than flat sheet connections:	
(a) When load is transmitted only by transverse welds	$U_{sl} = 1.0$ and $A_{nt}$ = Area of the directly connected elements
(b) When load is transmitted directly to all the cross sectional elements.	$U_{sl} = 1.0$
(c) For connections of angle members not meeting (a) or (b) above.	$U_{sl} = 1.0 - 1.20 \bar{x}/L \leq 0.9$ (Eq. E5.2-7) but $U_{sl}$ shall not be less than 0.4
(d) For connections of channel members not meeting (a) or (b) above.	$U_{sl} = 1.0 - 0.36 \bar{x}/L \leq 0.9$ (Eq. E5.2-8) but $U_{sl}$ shall not be less than 0.5

### E5.3 Block Shear Rupture

The nominal block shear rupture strength [resistance],  $R_n$ , shall be determined as the lesser of the following:

$$R_n = 0.6F_y A_{gv} + U_{st} U_{bs} F_u A_{nt} \quad (\text{Eq. E5.3-1})$$

$$R_n = 0.6F_u A_{nv} + U_{st} U_{bs} F_u A_{nt} \quad (\text{Eq. E5.3-2})$$

where

$A_{gv}$  = Gross area subject to shear (parallel to force)

- $A_{nv}$  = Net area subject to shear (parallel to force)  
 $A_{nt}$  = Net area subject to tension, except as noted in Table E5.2-1 (perpendicular to force)  
 $U_{st}$  = Staggered connectors factor as defined in Section E5.2  
 $U_{bs}$  = Non-uniform block shear factor  
= 0.5 for coped beam shear conditions with more than one vertical row of connectors  
= 1.0 for all other cases  
 $F_y$  = Yield stress of connected part as specified in Section A2.1 or A2.2  
 $F_u$  = Tensile strength of connected part as specified in Section A2.1 or A2.2

## E6 Connections to Other Materials

### E6.1 Bearing

Provisions shall be made to transfer *bearing* forces from steel components covered by this *Specification* to adjacent *structural components* made of other materials.

### E6.2 Tension

The pull-over shear/tension forces in the steel sheet around the head of the fastener shall be considered, as well as the pull-out force resulting from axial *loads* and bending moments transmitted onto the fastener from various adjacent *structural components* in the assembly.

The *nominal tensile strength [resistance]* of the fastener and the *nominal embedment strength [resistance]* of the adjacent structural component shall be determined by applicable product code approvals, product specifications, product literature, or combination thereof.

### E6.3 Shear

Provisions shall be made to transfer shearing forces from steel components covered by this *Specification* to adjacent structural components made of other materials. The required shear and/or *bearing* strength [factored force] on the steel components shall not exceed that allowed by this *Specification*. The *available shear strength [factored resistance]* on the fasteners and other material shall not be exceeded. Embedment requirements shall be met. Provisions shall also be made for shearing forces in combination with other forces.

## CHANGES AND UPDATES CHAPTER F, TESTS FOR SPECIAL CASES

1. On Page 105, change the definition for  $\beta_o$  to as follows:

- $\beta_o$  = Target reliability index
- = 2.5 for *structural members* and 3.5 for connections for LRFD
- = 1.6 for LRFD and LSD for an interior partition wall stud in a composite steel framed interior wall system with sheathing attached to both flanges and that is limited to a transverse (out-of-plane) nominal load of not more than 10 lb/ft<sup>2</sup> (0.48 kPa), a superimposed nominal axial load, exclusive of sheathing materials, of not more than 100 lb/ft (1.46 kN/m), or a superimposed nominal axial load of not more than 200 lbs (0.89 kN).
- = 1.5 for LRFD for beams having tension flange through-fastened to deck or sheathing and with compression flange laterally unbraced
- = 3.0 for structural members and 4.0 for connections for LSD
- = 3.0 for LSD for beams having tension flange through-fastened to deck or sheathing and with compression flange laterally unbraced

**CHANGES AND UPDATES IN APPENDIX 1**

1. Change "A1.1" to "A1.2" on page 1-3 on 8th line in the first paragraph, 5th line in the second paragraph, and 4th line in the 4th paragraph; on page 1-7 on 5th line; and on page 1-8 on 7th line in Section 1.2.2.
2. On page 1-3, replace "geometric and material limitations" with "criteria" on the 4th line under Section 1.1.1.
3. Under Section 1.1.1.1, Pre-qualified Columns, add the following as the second paragraph:

"Columns which fall outside the geometric and material limitations of Table 1.1.1-1 shall be permitted to still use the  $\Omega$  or  $\phi$  of Section 1.2.1 if through the use of Chapter F of the main *Specification* the predicted  $\phi$  from Chapter F provides an equal or higher  $\phi$  (equal or higher level of reliability) to that of Section 1.2.1. In the use of Chapter F, the professional factor,  $P$ , shall be the test-to-predicted ratio where the prediction is that of the Direct Strength Method expressions of Section 1.2.1,  $P_m$  is the mean of  $P$  and  $V_p$  the coefficient of variation of  $P$ . At least three tests shall be conducted. If  $V_p$  is less than or equal to 15%,  $C_p$  shall be permitted to be set to 1.0."
4. On page 1-4 of Appendix 1, in Table 1.1.1-1 for Hat Section, change from " $b_o/t < 20$ " to " $b_o/t < 43$ ".
5. Under Section 1.1.1.2, add the following as the second paragraph:

"Beams which fall outside the geometric and material limitations of Table 1.1.1-2 shall be permitted to still use the  $\Omega$  or  $\phi$  of Section 1.2.2 if through the use of Chapter F of the main *Specification* the predicted  $\phi$  from Chapter F provides an equal or higher  $\phi$  (equal or higher level of reliability) to that of Section 1.2.2. In the use of Chapter F, the professional factor,  $P$ , shall be the test-to-predicted ratio where the prediction is that of the Direct Strength Method expressions of Section 1.2.2,  $P_m$  is the mean of  $P$  and  $V_p$  the coefficient of variation of  $P$ . At least three tests shall be conducted. If  $V_p$  is less than or equal to 15% then  $C_p$  is permitted to be set to 1.0."

**CHANGES AND UPDATES IN APPENDIX A**

1. On Page A-4, delete reference "AISI S213-07, North American Standard for Cold-Formed Steel Framing – Lateral Design"
2. Delete Section C2.
3. Delete Section D4a.
4. Replace the sections starting from E2a to the end of the Appendix A by the following:

**E2a Welded Connections**

Welded connections in which the *thickness* of the thinnest connected part is greater than 3/16 in. (4.76 mm) shall be in accordance with ANSI/AISC-360.

Except as modified herein, arc welds on steel where at least one of the connected parts is 3/16 in. (4.76 mm) or less in thickness shall be made in accordance with AWS D1.3. Welders and welding procedures shall be qualified as specified in AWS D1.3. These provisions shall apply to the welding positions as listed in Table E2a.

Resistance welds shall be made in conformance with the procedures given in AWS C1.1 or AWS C1.3.

**TABLE E2a**  
**Welding Positions Covered**

Connection	Welding Position					
	Square Groove Butt Weld	Arc Spot Weld	Arc Seam Weld	Fillet Weld, Lap or T	Flare-Bevel Groove	Flare-V Groove Weld
Sheet to Sheet	F	—	F	F	F	F
	H	—	H	H	H	H
	V	—	—	V	V	V
	OH	—	—	OH	OH	OH
Sheet to Supporting Member	—	F	F	F	F	—
	—	—	—	H	H	—
	—	—	—	V	V	—
	—	—	—	OH	OH	—

(F = Flat, H = horizontal, V = vertical, OH = overhead)

**E3a Bolted Connections**

In addition to the design criteria given in Section E3 of the *Specification*, the following design requirements shall also be followed for bolted connections used for *cold-formed steel structural members*, in which the *thickness* of the thinnest connected part is 3/16 in. (4.76 mm) or less. Bolted *connections* in which the thickness of the thinnest connected part is greater than 3/16 in. (4.76 mm) shall be in accordance with ANSI/AISC-360.

The holes for bolts shall not exceed the sizes specified in Table E3a, except that larger holes are permitted to be used in column base details or structural systems connected to concrete walls.

Standard holes shall be used in bolted connections, except that oversized and slotted holes shall be permitted to be used as approved by the designer. The length of slotted holes shall be normal to the direction of the shear load. Washers or backup plates shall be installed over oversized or slotted holes in an outer ply unless suitable performance is demonstrated by tests in accordance with Chapter F.

**TABLE E3a**  
**Maximum Size of Bolt Holes, inches**

Nominal Bolt Diameter, d in.	Standard Hole Diameter, $d_h$ in.	Oversized Hole Diameter, $d_h$ in.	Short-Slotted Hole Dimensions in.	Long-Slotted Hole Dimensions in.
$< 1/2$	$d + 1/32$	$d + 1/16$	$(d + 1/32)$ by $(d + 1/4)$	$(d + 1/32)$ by $(2^{1/2} d)$
$\geq 1/2$	$d + 1/16$	$d + 1/8$	$(d + 1/16)$ by $(d + 1/4)$	$(d + 1/16)$ by $(2^{1/2} d)$

**TABLE E3a**  
**Maximum Size of Bolt Holes, millimeters**

Nominal Bolt Diameter, d mm	Standard Hole Diameter, $d_h$ mm	Oversized Hole Diameter, $d_h$ mm	Short-Slotted Hole Dimensions mm	Long-Slotted Hole Dimensions mm
$< 12.7$	$d + 0.8$	$d + 1.6$	$(d + 0.8)$ by $(d + 6.4)$	$(d + 0.8)$ by $(2^{1/2} d)$
$\geq 12.7$	$d + 1.6$	$d + 3.2$	$(d + 1.6)$ by $(d + 6.4)$	$(d + 1.6)$ by $(2^{1/2} d)$

#### E3.4 Shear and Tension in Bolts

The nominal bolt strength,  $P_n$ , resulting from shear, tension or a combination of shear and tension shall be calculated in accordance with this section. The corresponding *safety factor* and the *resistance factor* provided in Table E3.4-1 shall be used to determine the *available strengths* in accordance with the applicable method in Section A4 or A5.

$$P_n = A_b F_n \quad (\text{Eq. E3.4-1})$$

where

$A_b$  = Gross cross-sectional area of bolt

$F_n$  = Nominal strength ksi (MPa), is determined in accordance with (a) or (b) as follows:

(a) When bolts are subjected to shear only or tension only

$F_n$  shall be given by  $F_{nv}$  or  $F_{nt}$  in Table E3.4-1.

Corresponding *safety* and *resistance factors*,  $\Omega$  and  $\phi$ , shall be in accordance with Table E3.4-1.

The pullover strength of the connected sheet at the bolt head, nut or washer shall be considered where bolt tension is involved. See Section E6.2.

(b) When bolts are subjected to a combination of shear and tension,  $F_n$  is given by  $F'_{nt}$



in Eq. E3.4-2 or E3.4-3 as follows

For ASD

$$F'_{nt} = 1.3 F_{nt} - \frac{\Omega F_{nt}}{F_{nv}} f_v \leq F_{nt} \quad (\text{Eq. E3.4-2})$$

For LRFD

$$F'_{nt} = 1.3 F_{nt} - \frac{F_{nt}}{\phi F_{nv}} f_v \leq F_{nt} \quad (\text{Eq. E3.4-3})$$

where

$F'_{nt}$  = Nominal tensile stress modified to include the effects of required shear stress, ksi (MPa)

$F_{nt}$  = Nominal tensile stress from Table E3.4-1

$F_{nv}$  = Nominal shear stress from Table E3.4-1

$f_v$  = Required shear stress, ksi (MPa)

$\Omega$  = Safety factor for shear from Table E3.4-1

$\phi$  = Resistance factor for shear from Table E3.4-1

In addition, the required shear stress,  $f_v$ , shall not exceed the allowable shear stress,  $F_{nv} / \Omega$  (ASD) or the design shear stress,  $\phi F_{nv}$  (LRFD), of the fastener.

In Table E3.4-1, the shear strength shall apply to bolts in holes as limited by Table E3a. Washers or back-up plates shall be installed over long-slotted holes and the capacity of connections using long-slotted holes shall be determined by load tests in accordance with Chapter F.

**TABLE E3.4-1**  
**Nominal Tensile and Shear Strengths for Bolts**

	Tensile Strength			Shear Strength		
	Safety Factor $\Omega$ (ASD)	Resistance Factor $\phi$ (LRFD)	Nominal Stress $F_{nt}$ , ksi (MPa)	Safety Factor $\Omega$ (ASD)	Resistance Factor $\phi$ (LRFD)	Nominal Stress $F_{nv}$ , ksi (MPa)
A307 Bolts, Grade A $1/4$ in. (6.4 mm) $\leq d$ $< 1/2$ in. (12.7 mm)	2.25	0.75	40.5 (279)	2.4	0.65	24.0 (165)
A307 Bolts, Grade A $d \geq 1/2$ in. (12.7 mm).	2.25		45.0 (310)			27.0 (186)
A325 bolts, when threads are not excluded from shear planes	2.0		90.0 (621)			54.0 (372)
A325 bolts, when threads are excluded from shear planes			90.0 (621)			72.0 (496)
A354 Grade BD Bolts $1/4$ in. (6.4 mm) $\leq d < 1/2$ in. (12.7 mm), when threads are not excluded from shear planes			101.0 (696)			59.0 (407)
A354 Grade BD Bolts $1/4$ in. (6.4 mm) $\leq d < 1/2$ in. (12.7 mm), when threads are excluded from shear planes			101.0 (696)			90.0 (621)
A449 Bolts $1/4$ in. (6.4 mm) $\leq d < 1/2$ in. (12.7 mm), when threads are not excluded from shear planes			81.0 (558)			47.0 (324)
A449 Bolts $1/4$ in. (6.4 mm) $\leq d < 1/2$ in. (12.7 mm), when threads are excluded from shear planes			81.0 (558)			72.0 (496)
A490 Bolts, when threads are not excluded from shear planes			112.5 (776)			67.5 (465)
A490 Bolts, when threads are excluded from shear planes			112.5 (776)			90.0 (621)

**E5a Rupture**

Connections in which the thickness of the thinnest part is greater than 3/16 in. (4.76 mm) shall be in accordance with ANSI/AISC 360.

## CHANGES AND UPDATES IN APPENDIX B

1. Delete Section C2 and the sub-sections under C2.
2. Replace all the sections starting from E2a to the end of Appendix B with the followings:

### E2a Welded Connections

Arc welding shall be performed by a fabricator or erector certified in accordance with CSA W47.1. Resistance welding shall be performed by a fabricator or erector certified in accordance with CSA W55.3.

Where each connected part is over 4.76 mm in base steel thickness, welding shall conform to CSA W59. Where at least one of the connected parts is between 0.70 and 4.76 mm in base steel thickness, welding shall conform to the requirements contained herein and shall be performed in accordance with the applicable requirements of CSA W59. Except as provided for in Section E2.2, where at least one of the connected parts is less than 0.70 mm in base steel thickness, welds shall be considered to have no structural value unless a value is substantiated by appropriate tests.

The resistance in tension or compression of butt welds shall be the same as that prescribed for the lower strength of base metal being joined. The butt weld shall fully penetrate the joint.

#### E2.2a Arc Spot Welds

This section replaces the first paragraph of Section E2.2 but does not pertain to Section E2.2.2.2 and E2.3.2.2.

Arc spot welds (circular in shape) covered by this *Specification* are for welding sheet steel to thicker supporting members in the flat position. The weld is formed by melting through the steel sheet to fuse with the underlying supporting member, whose thickness at the weld location shall be at least 2.5 times the steel sheet thickness (aggregate sheet thickness in the case of multiple plies). The materials to be joined shall be of weldable quality, and the electrodes to be used shall be suited to the materials, the welding method, and the ambient conditions during welding.

The following maximum and minimum sheet thicknesses shall apply:

- (a) maximum single sheet thickness shall be 2.0 mm;
- (b) minimum sheet thickness shall be 0.70 mm; and
- (c) maximum aggregate sheet thickness of double sheets shall be 2.5 mm.

#### E2.3a Arc Seam Welds

The information in Section E2.2a also applies to arc seam welds that are oval in shape.

### E3a Bolted Connections

In addition to the design criteria given in Section E3 of the *Specification*, the following design requirements shall be followed for bolted connections used for *cold-formed steel structural members* in which the *thickness* of the thinnest connected part is 4.76 mm or less, there are no gaps between connected parts, and fasteners are installed with sufficient tightness to achieve

satisfactory performance of the connection under anticipated service conditions. Bolted connections in which the thickness of the thinnest connected part is greater than 4.76 mm shall be in accordance with CSA Standard S16.

Unless otherwise specified, circular holes for bolts shall not be greater than the nominal bolt diameter,  $d$ , plus 1 mm for bolt sizes up to 13 mm and plus 2 mm for bolt sizes over 13 mm.

### E3.3a Bearing

When the thickness of connected steels is equal to or larger than 4.76 mm, the requirements of CSA S16 shall be met for connection design.

### E3.4 Shear and Tension in Bolts

For ASTM A 307 bolts less than 12.7 mm in diameter, refer to Tables E3.4-1 and E3.4-2 of this Appendix. For all other bolts, refer to CSA S16.

The nominal bolt resistance,  $P_n$ , resulting from shear, tension, or a combination of shear and tension shall be calculated as follows:

$$P_n = A_b F_n \quad (\text{Eq. E3.4-1})$$

where

$A_b$  = Gross cross-sectional area of bolt

$F_n$  = A value determined in accordance with i) and ii) below, as applicable:

i) When bolts are subjected to shear or tension

$F_n$  is given by  $F_{nt}$  or  $F_{nv}$  in Table E3.4-1, as well as the  $\phi$  values

ii) When bolts are subjected to a combination of shear and tension

$F_n$  is given by  $F'_{nt}$  in Table E3.4-2, as well as the  $\phi$  value

The pull-over resistance of the connected sheet at the bolt head, nut, or washer shall be considered where bolt tension is involved. See Section E6.2 of the *Specification*.

**TABLE E3.4-1**  
**Nominal Tensile and Shear Stresses for Bolts**

Description of Bolts	Nominal Tensile Stress, $F_{nt}$ (MPa)	Resistance Factor, $\phi$	Nominal Shear Stress, $F_{nv}$ (MPa)	Resistance Factor, $\phi$
A307 Bolts, Grade A $6.4 \text{ mm} \leq d < 12.7 \text{ mm}$	279	0.65	165	0.55

**TABLE E3.4-2**  
**Nominal Tensile Stress for Bolts**  
**Subjected to the Combination of Shear and Tension**

Description of Bolts	Nominal Tensile Stress, $F'_{nt}$ (MPa)	Resistance Factor, $\phi$
A307 Bolts, Grade A When $6.4 \text{ mm} \leq d < 12.7 \text{ mm}$	$324 - 2.4f_v \leq 279$	0.65

The actual shear stress,  $f_v$ , shall also satisfy Table E3.4-1 of this Appendix.

### **E5a Rupture**

When the thickness of connected steels is larger than 4.76 mm, the requirements of CAN/CSA S16 shall be met for connection design.

For connection types utilizing screws, the nominal rupture strength [resistance],  $R_n$ , shall be the lesser of the values obtained in accordance with Sections E5.1, E5.2 and E5.3 as applicable.” to bottom of paragraph as detailed below.



**COMMENTARY ON SUPPLEMENT NO. 2  
TO THE NORTH AMERICAN SPECIFICATION  
FOR THE DESIGN OF COLD-FORMED STEEL  
STRUCTURAL MEMBERS, 2007 EDITION**

**FEBRUARY 2010**

**CHANGES AND UPDATES TO CHAPTER A THROUGH F**

**CHANGES AND UPDATES IN COMMENTARY ON CHAPTER B, ELEMENTS**

1. Add Section B2.5, Uniformly Compressed Elements Restrained by Intermittent Connections, as follows:

**B2.5 Uniformly Compressed Elements Restrained by Intermittent Connections**

Section D1.3 limits the spacing of connections in compression elements so that the strength of the section is fully developed before buckling occurs between connections. In practice this limit is often exceeded. Luttrell and Balaji (1992) and Snow and Easterling (2008) developed a method to determine the effective width of compression elements when greater connection spacing exists. The Snow and Easterling method is given in *Specification* Section B2.5 and is founded on 82 standard roof deck tests. All test specimens had multiple flutes and the depth range was between 1 ½ in. (38 mm) and 7 ½ in. (191 mm). As shown in Figures C-B2.5-1 and C-B2.5-2, all test compression plates had edge stiffeners.

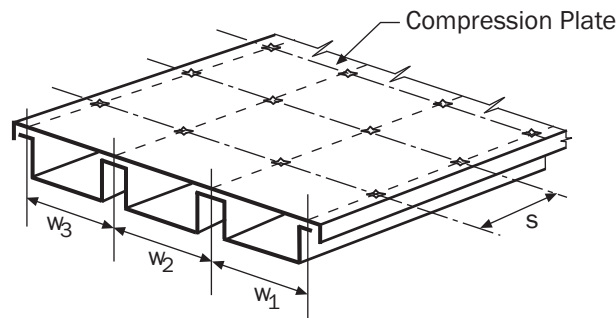

**Figure C-B2.5-1 Built-Up Deck**

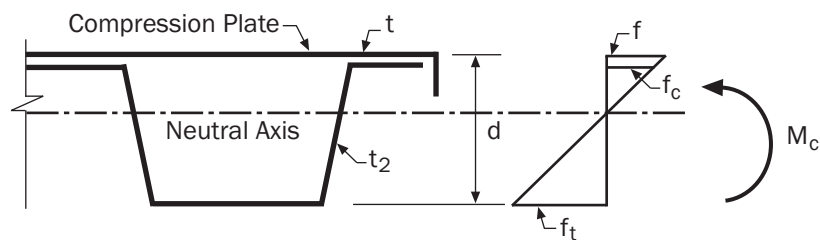

**Figure C-B2.5-2 Built-Up Deck in Bending**



Figure C-B2.5-2 shows the built-up deck section in bending. In Figures C-B2.5-1 and C-B2.5-2,  $s$  and  $w$  are the center-to-center connection spacing along and across the compression plate, respectively;  $t$  and  $t_2$  are the thicknesses of the cover plate and the deck, respectively;  $f$  is the compression stress in the cover plate,  $f_c$  and  $f_t$  are the maximum compression and tension stresses in the deck, respectively; and  $d$  is the overall depth of the built-up member.

The full stress potential of the “built up” section is determined recognizing the post-buckling strength of the compression plate after local waves form between connections. The method models an equivalent composite transformed section and maintains the classical assumption of linear strain distribution. The critical compression stress,  $F_c$  is based on “column like” buckling in the plate. The connections provide fixed end column restraint and  $K = 0.5$ . When the stress level,  $f$ , in compression plate reaches the critical stress,  $F_c$  the stress in compression plate will no longer increase, while the stress level in the deck,  $f_c$ , may continue to increase due to its compactness. An equivalent width is determined to provide the approximate true force contribution of the buckled plate in resisting bending. This equivalent width is assumed to have an artificially high stress,  $f$ , which is compatible with both a constant “E” and linear strain distribution across the “built up” section. The equivalent transformed section properties cannot be greater than the section calculated using *Specification* Section B2.1. The moment of inertia for deflection is determined by substituting the maximum stress at service load for  $F_y$  and the compression stress at service load,  $f_d$ , for  $f$  in Section B2.5.

Jones (Jones, et al, 1997) validated the Luttrell’s method (1992) but the researchers cautioned its use for single fluted members having compression plates with edge stiffeners. Luttrell and Balaji (1992) tested built-up deck with compression plate thickness between 0.045 in. (1.14 mm) and 0.06 in. (1.52 mm). Jones (1997) investigated unstiffened cover plates to .017 inch thickness. The UMR research indicated that the method worked reasonably well for single fluted members having unstiffened compression plates when the plate thickness exceeded 0.045 inches.

2. On page 44, add the following paragraphs before Figure C-B5.1-1:

“In 2010, *Specification* Equation B5.1.1-1 was replaced by

$$k_{loc} = 4(b_o/b_p)^2 \quad (C-B5.1-1)$$

where

$k_{loc}$  = plate buckling coefficient of element

$b_o$  = total flat width of stiffened element

$b_p$  = sub-element flat width for flange with equally spaced stiffeners

This replacement ensures that *Specification* Sections B5.1.1 and B5.1.2 provide the same answer for sub-element local buckling, and replaces the overly conservative estimate of the 2007 edition of the *Specification* Equation B5.1.1-1, which ignored the stiffener width (Schafer 2009). “

## CHANGES AND UPDATES IN COMMENTARY ON CHAPTER C, MEMBERS

1. On page 47, on second to the last line in Section C3.1, replace “...nominal bending strength...” with “...available bending strength...”.

2. On page 49, replace the paragraph between lines 4 to 9 with the paragraph below:

“Prior to the 2008 edition the design flexural strength [factored resistance],  $\phi_b M_{nr}$ , employed different  $\phi_b$  factors depending on the compression flange. Based on the 1991 edition of the *AISI Specification*, and Hsiao, Yu and Galambos (1988a), unstiffened flanges were specified at  $\phi_b = 0.90$  and edge stiffened or stiffened flanges at  $\phi_b = 0.95$  (ASD used one  $\Omega$  factor for all cases). Examination of more recently available test data (Schafer and Trestain, 2002; Yu and Schafer, 2003), and consideration of the fact that the higher  $\phi_b$  existed in part due to inelastic reserve strength, which is already addressed in *Specification* Section C3.1.1(b), a uniform  $\phi_b = 0.90$  was adopted for all members. This change also removed a conflict with the  $\phi_b$  factors adopted in 2007 for *Specification* Section C3.1.4, when the member is fully effective.”

3. Replace Section C3.1.4 as follows:

#### **C3.1.4 Distortional Buckling Strength [Resistance]**

Distortional buckling is an instability that may occur in members with edge stiffened flanges, such as lipped C- and Z-sections. As shown in Figure C-C3.1.4-1, this buckling mode is characterized by instability of the entire flange, as the flange along with the edge stiffener rotates about the junction of the compression flange and the web. The length of the buckling wave in distortional buckling is considerably longer than local buckling, and noticeably shorter than lateral-torsional buckling. The *Specification* provisions of Section B4 partially account for distortional buckling, but research has shown that a separate limit state check is required (Ellifritt, Sputo, and Haynes 1992, Hancock, Rogers, and Schuster 1996, Kavanagh and Ellifritt 1994, Schafer and Peköz 1999, Hancock 1997, Yu and Schafer 2003, 2006). Thus, in 2007, *Specification* Section C3.1.4 was added to address distortional buckling as a separate limit state.

Determination of the nominal strength in distortional buckling (*Specification* Equation C3.1.4-2) was validated by testing. Results of one such study (Yu and Schafer 2006) are shown in Figure C-C3.1.4-2. The Direct Strength Method of Appendix 1 of the *Specification* also uses Equation C3.1.4-2. In addition, the Australian/New Zealand Specification (AS/NZS 4600) has used Equation C3.1.4-2 since 1996. Calibration of the safety and resistance factors for Equation C3.1.4-2 is provided in the commentary to Appendix 1.

Distortional buckling is unlikely to control the strength if (a) edge stiffeners are sufficiently stiff and thus stabilize the flange (as is often the case for C-sections, but typically not for Z-sections due to the use of sloping lips), (b) unbraced lengths are long and lateral-torsional buckling strength limits the capacity, or (c) adequate rotational restraint is provided to the compression flange from attachments (panels, sheathing, etc.).

The primary difficulty in calculating the strength in distortional buckling is to efficiently estimate the elastic distortional buckling stress,  $F_d$ . Recognizing the complexity of this calculation, this *Specification* section provides two alternatives: C3.1.4(a) provides a more comprehensive method for C- and Z-Section members and any open section with a single web and single edge stiffened compression flange, and C3.1.4(b) offers the option to use rational elastic buckling analysis, e.g., see the Appendix 1 commentary. In 2010, the *Simplified Provision for Unrestrained C- and Z-Sections with Simple Lip Stiffeners* was moved

from the *Specification* to the *Commentary*. This provision provides a conservative approximation to the distortional buckling length,  $L_{cr}$ , and stress,  $F_d$ , for C- and Z-sections with simple lip stiffeners bent about an axis perpendicular to the web. The provision ignores any rotational restraint, which would restrain distortional buckling. The expressions were specifically derived as a conservative simplification to those provided in *Specification* Sections C3.1.4(a) and (b). For many common sections, the simplified method may be used to show that distortional buckling of the column will not control the capacity. *Specification* provisions C3.1.4(a) or (b), however, should be used to obtain the distortional buckling strength [resistance] if distortional buckling controls the design.

*Simplified Method for Unrestrained C- and Z-Sections with Simple Lip Stiffeners*

For C- and Z-sections that have no rotational restraint of the compression flange and are within the dimensional limits provided in this section, Equation C-C3.1.4-1 can be used to calculate a conservative prediction of the distortional buckling stress,  $F_d$ . See *Specification* Section C3.1.4(a) or C3.1.4(b) for alternative provisions and for members outside the dimensional limits.

The following dimensional limits should apply:

- (1)  $50 \leq h_o/t \leq 200$ ,
- (2)  $25 \leq b_o/t \leq 100$ ,
- (3)  $6.25 < D/t \leq 50$ ,
- (4)  $45^\circ \leq \theta < 90^\circ$ ,
- (5)  $2 \leq h_o/b_o \leq 8$ , and
- (6)  $0.04 \leq D \sin\theta/b_o \leq 0.5$ .

where

$h_o$  = Out-to-out web depth as defined in *Specification* Figure B2.3-2

$t$  = Base steel *thickness*

$b_o$  = Out-to-out flange width as defined in *Specification* Figure B2.3-2

$D$  = Out-to-out lip dimension as defined in *Specification* Figure B4-1

$\theta$  = Lip angle as defined in *Specification* Figure B4-1

The distortional buckling stress,  $F_d$ , can be calculated as follows:

$$F_d = \beta k_d \frac{\pi^2 E}{12(1-\mu^2)} \left( \frac{t}{b_o} \right)^2 \quad (\text{C-C3.1.4-1})$$

where

$\beta$  = A value accounting for moment gradient, which is permitted to be conservatively taken as 1.0

$$= 1.0 \leq 1 + 0.4(L/L_m)^{0.7} (1 + M_1/M_2)^{0.7} \leq 1.3 \quad (\text{C-C3.1.4-2})$$

where

$L$  = Minimum of  $L_{cr}$  and  $L_m$

where

$$L_{cr} = 1.2 h_o \left( \frac{b_o D \sin\theta}{h_o t} \right)^{0.6} \leq 10 h_o \quad (\text{C-C3.1.4-3})$$

$L_m$  = Distance between discrete restraints that restrict distortional buckling  
(for continuously restrained members  $L_m=L_{cr}$ )

$M_1$  and  $M_2$  = The smaller and the larger end moment, respectively, in the unbraced segment ( $L_m$ ) of the beam;  $M_1/M_2$  is negative when the moments cause reverse curvature and positive when bent in single curvature

$$k_d = 0.5 \leq 0.6 \left( \frac{b_o D \sin \theta}{h_o t} \right)^{0.7} \leq 8.0 \quad (\text{C-C3.1.4-4})$$

$E$  = Modulus of elasticity

$\mu$  = Poisson's ratio

The equations C-C3.1.4-1 to C-C3.1.4-4 assume the compression flange is unrestrained; however, the methods of C3.1.4(a) and (b) allow for a rotational restraint,  $k_\phi$ , to be included to account for attachments which restrict flange rotation.

#### $k_\phi$ Determination

While it is always conservative to ignore the rotational restraint,  $k_\phi$ , in many cases it may be beneficial to include this effect. Due to the large variety of possible conditions, no specific method is provided for determining the rotational restraint. Instead, per Section A1.2 of the *Specification*,  $k_\phi$  may be estimated by testing or rational engineering analysis. Test determination of  $k_\phi$  may use AISI S901 (AISI 2002).  $K$  from this method is a lower bound estimate of  $k_\phi$ . The member lateral deformation may be removed from the measured lateral deformation to provide a more accurate estimate of  $k_\phi$ .

Testing on 8 in. and 9.5 in. (203 and 241 mm) deep Z-sections with a thickness between 0.069 in. (1.75 mm) and 0.118 in. (3.00 mm), through-fastened 12 in. (205 mm) o.c., to a 36 in. (914 mm) wide, 1 in. (25.4 mm) and 1.5 in. (38.1 mm) high steel panels, with up to 6 in. (152 mm) of blanket insulation between the panel and the Z-section, results in a  $k_\phi$  between 0.15 to 0.44 kip-in./rad./in. (0.667 to 1.96 kN-mm/rad./mm) (MRI 1981).

Additional testing on C- and Z-sections with pairs of through-fasteners provides considerably higher rotational stiffness: for 6 and 8 in. (152 and 203 mm) deep C-sections with a thickness between 0.054 and 0.097 in. (1.27 and 2.46 mm), fastened with pairs of fasteners on each side of a 1.25 in. (31.8 mm) high steel panel flute at 12 in. (305 mm) o.c.,  $k_\phi$  is 0.4 kip-in./rad./in. (1.78 kN-mm/rad./mm); and for 8.5 in. (216 mm) deep Z-sections with a thickness between 0.070 in. and 0.120 in. (1.78 mm to 3.05 mm), fastened with pairs of fasteners on each side of 1.25 in. (31.8 mm) high steel panel flute at 12 in. (305 mm) o.c.,  $k_\phi$  is 0.8 kip-in./rad./in. (3.56 kN-mm/rad./mm) (Yu and Schafer 2003, Yu 2005).

Examples of rational engineering analysis to estimate the rotational stiffness are provided in the Direct Strength Method Design Guide (AISI 2006). For a flexural member,  $k_\phi$  can be approximated as:

$$k_\phi \approx EI/(W/2) \quad (\text{C-C3.1.4-5})$$

where  $E$  is the modulus of the attached material,  $I$  is the moment of inertia of the engaged attachment, and  $W$  is the member spacing. The primary complication in such a method is determining how much of the attachment (decking, sheathing, etc.) is engaged when the flange attempts to deform. For the Z-sections tested in Yu (2005) experimental  $k_\phi$  is 0.8 kip-in./rad./in. (3.56 kN-mm/rad./mm). Using an estimate of  $EI/(W/2)$  the rational

engineering values are  $k_\phi$  of 9 kip-in./rad./in. (40.0 kN-mm/rad./mm) if the entire panel, flutes and all, are engaged;  $k_\phi$  of 1.2 kip-in./rad./in. (5.34 kN-mm/rad./mm) if only the corrugated bottom panel, but not the flutes, is engaged; and  $k_\phi$  of 0.003 kip-in./rad./in. (0.0133 kN-mm/rad./mm) if plate bending of the  $t = 0.019$  in. (0.483 mm) panel occurs. The observed panel engagement is between the last two estimates, and assuming the corrugated bottom panel, but not the 1.25 in. (31.8 mm) high flutes is engaged is reasonable.

For members with wood sheathing attached, little experimental information is available. The problem has been studied numerically using the same paired fastener detail as in Yu's (2005) and Yu and Schafer (2003) tests but replacing the steel panel with a simulated wood member, thickness = 0.5 in. (12.7 mm),  $E = 1000$  ksi (6900 MPa), and  $\mu = 0.3$ . The calculated  $k_\phi$  is 5.1 kip-in./rad./in. (22.7 kN-mm/rad./mm) for 6 and 8 in. (152 to 203 mm) deep C-sections with a thickness between 0.054 and 0.097 in. (1.37 and 2.46 mm); and  $k_\phi$  is 4.1 kip-in./rad./in. (18.2 kN-mm/rad./mm) for 8.5 in. (216 mm) deep Z-sections with thickness between 0.070 and 0.120 in. (1.78 mm and 3.05 mm). From calculations assuming a fully engaged 1/2 in. (12.7 mm) thick wood sheet on top of C- or Z-section members spaced 12 in. (305 mm) apart,  $k_\phi$  is predicted to be 1.7 kip-in./rad./in. (7.56 kN-mm/rad./mm). Thus, use of  $EI/(W/2)$  provides a reasonably conservative approximation, with  $I$  calculated assuming the full engagement of wood sheet.

The presence of moment gradient can also increase the distortional buckling moment (or equivalently stress,  $F_d$ ). However, this increase is lessened if the moment gradient occurs over a longer length. Thus, in determining the influence of moment gradient ( $\beta$ ) the ratio of the end moments,  $M_1/M_2$ , and the ratio of the critical distortional buckling length to the unbraced length,  $L/L_{mv}$ , should both be accounted for. In 2010, the sign convention on the ratio of moments  $M_1$  and  $M_2$  was changed to be consistent with moment gradient expressions for  $C_{TF}$  (*Specification* Equation C3.1.2.1-12) and  $C_M$  (*Specification* Equation C5.2.1-8) used elsewhere in the *Specification*. *Specification* Equation C3.1.4-7 were revised accordingly. Yu (2005) performed elastic buckling analysis with shell finite element models of C- and Z-sections under different moment gradients to examine this problem. Significant scatter exists in the results, therefore a lower bound prediction (*Specification* Equation C3.1.4-7) for the increase was selected.

(a) For C- and Z-Sections or any Open Section with a Stiffened Compression Flange Extending to One Side of the Web where the Stiffener is either a Simple Lip or a Complex Edge Stiffener

The provisions of *Specification* Section C3.1.4(a) provide a general method for calculation of the distortional buckling stress,  $F_d$ , for any open section with an edge stiffened compression flange, including complex edge stiffeners. The provisions of *Specification* Section C3.1.4(a) also provide a more refined answer for any C- and Z-section including those meeting the dimensional criteria of the *Simplified Provision for Unrestrained C- and Z-Sections with Simple Lip Stiffeners* presented in this commentary. The expressions employed here are derived in Schafer and Peköz (1999) and verified for complex stiffeners in Schafer et al. (2006). The equations used for the distortional buckling stress,  $F_d$ , in AS/NZS 4600 are also similar to those in *Specification* Section C3.1.4 (a), except that when the web is very slender and is restrained by the flange, AS/NZS 4600 uses a simpler, conservative treatment. Since the provided expressions can be complicated, solutions for the geometric properties of C- and Z-sections based on centerline dimensions are provided in Table C-C3.1.4(a)-1.

(b) Rational Elastic Buckling Analysis

Rational elastic buckling analysis consists of any method following the principles of mechanics to arrive at an accurate prediction of the elastic distortional buckling stress (moment). It is important to note that this is a rational elastic buckling analysis and not simply an arbitrary rational method to determine ultimate strength. A variety of rational computational and analytical methods can provide the elastic buckling moment with a

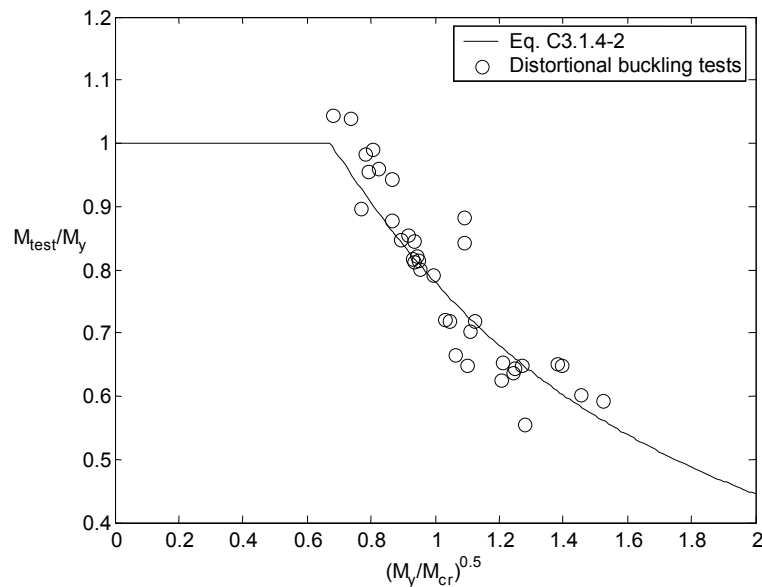

**Figure C-C3.1.4-2 Performance of Distortional Buckling Prediction with Test Data on Common C- and Z-sections in Bending (Yu and Schafer 2006)**

high degree of accuracy. Complete details are provided in Section 1.1.2 of the commentary to Appendix 1 of the *Specification*. The safety and resistance factors of this section have been shown to apply to a wide variety of cross-sections undergoing distortional buckling (via the methods of Appendix 1). As long as the member falls within the geometric limits of main *Specification* Section B1.1, the same safety and resistance factors have been assumed to apply. Application of the  $\beta$  expression, to account for moment gradient, as provided in *Specification* Section C3.1.4(a) is a rational extension to solutions which do not typically account for moment gradient such as the finite strip method.

**Table C-C3.1.4(a)-1**  
**Geometric Flange Properties for C- and Z-Sections**

$A_f = (b+d)t$	$A_f = (b+d)t$
$J_f = \frac{1}{3}bt^3 + \frac{1}{3}dt^3$	$J_f = \frac{1}{3}bt^3 + \frac{1}{3}dt^3$
$I_{xf} = \frac{t(t^2b^2 + 4bd^3 + t^2bd + d^4)}{12(b+d)}$	$I_{xf} = \frac{t(t^2b^2 + 4bd^3 - 4bd^3 \cos^2(\theta) + t^2bd + d^4 - d^4 \cos^2(\theta))}{12(b+d)}$
$I_{yf} = \frac{t(b^4 + 4db^3)}{12(b+d)}$	$I_{yf} = \frac{t(b^4 + 4db^3 + 6d^2b^2 \cos(\theta) + 4d^3b \cos^2(\theta) + d^4 \cos^2(\theta))}{12(b+d)}$
$I_{xyf} = \frac{tb^2d^2}{4(b+d)}$	$I_{xyf} = \frac{tbd^2 \sin(\theta)(b+d \cos(\theta))}{4(b+d)}$
$C_{wf} = 0$	$C_{wf} = 0$
$x_{of} = \frac{b^2}{2(b+d)}$	$x_{of} = \frac{b^2 - d^2 \cos(\theta)}{2(b+d)}$
$h_{xf} = \frac{-(b^2 + 2db)}{2(b+d)}$	$h_{xf} = \frac{-(b^2 + 2db + d^2 \cos(\theta))}{2(b+d)}$
$h_{yf} = y_{of} = \frac{-d^2}{2(b+d)}$	$h_{yf} = y_{of} = \frac{-d^2 \sin(\theta)}{2(b+d)}$

4. On page 65, change the last sentence in the paragraph below Equation C-C3.3-2 to  
 “The above equation was found to be conservative for beam webs with adequate shear stiffeners, for which a diagonal tension field action may be developed. Based on the studies made by LaBoube and Yu (1978b), Equation C-C3.3-3 was developed for beam webs with shear stiffeners satisfying the requirements of *Specification* Section C3.7.3.”
5. Replace Section C4.2 with the following:

#### **C4.2 Distortional Buckling Strength [Resistance]**

Distortional buckling is an instability that may occur in members with edge stiffened flanges, such as lipped C- and Z-sections. As shown in Figure C-C4.2-1, this buckling mode is characterized by instability of the entire flange, as the flange along with the edge stiffener rotates about the junction of the flange and the web. The length of the buckling wave in distortional buckling is considerably longer than local buckling, and noticeably shorter than flexural or flexural-torsional buckling. The *Specification* provisions of Section B4 partially account for distortional buckling, but research has shown that a separate limit state check is required (Schafer 2002). Thus, in 2007, treating distortional buckling as a separate limit state, *Specification* Section C3.1.4 was added to address distortional buckling in beams and *Specification* Section C4.2 was added to address distortional buckling in columns. Note, as

stated in the *Specification*, when a member is designed in accordance with Section D6.1.3, Compression Members Having One Flange Through-Fastened to Deck or Sheathing, the Section C4.2 Distortional Buckling Strength provisions need not be applied since distortional buckling is inherently included as a limit state in the Section D6.1.3 strength prediction equations.

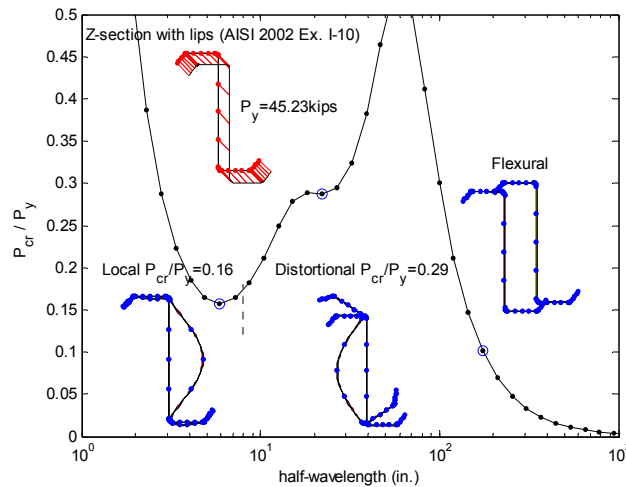

**Figure C-C4.2-1 Rational Elastic Buckling Analysis of a Z-Section under Compression Showing Local, Distortional, and Flexural Buckling Modes**

Determination of the nominal strength in distortional buckling (*Specification* Equation C4.2-2) was validated by testing. *Specification* Equation C4.2-2 was originally developed for the Direct Strength Method of Appendix 1 of the *Specification*. Calibration of the safety and resistance factors for *Specification* Equation C4.2-2 is provided in the commentary to Appendix 1. In addition, the Australian/New Zealand Specification (AS/NZS 4600) has used an expression of similar form to *Specification* Equation C4.2-2, but yielding slightly less conservative strength predictions than Equation C4.2-2, since 1996.

Distortional buckling is unlikely to control the strength of a column if (a) the web is slender and triggers local buckling far in advance of distortional buckling, as is the case for many common C-sections, (b) edge stiffeners are sufficiently stiff and thus stabilize the flange (as is often the case for C-sections, but typically not for Z-sections due to the use of sloping lip stiffeners), (c) unbraced lengths are long and flexural or flexural-torsional buckling strength limits the capacity, or (d) adequate rotational restraint is provided to the flanges from attachments (panels, sheathing, etc.).

The primary difficulty in calculating the strength in distortional buckling is to efficiently estimate the elastic distortional buckling stress,  $F_d$ . Recognizing the complexity of this calculation this section of the *Specification* provides two alternatives: *Specification* Section C4.2(a) provides a comprehensive method for C- and Z-Section members and any open section with a single web and flanges of the same dimension, and Section C4.2(b) offers the option to use rational elastic buckling analysis. See the Appendix 1 commentary for further discussion. In 2010, the *Simplified Provision for Unrestrained C- and Z-Section with Simple Lip Stiffeners*, was moved from the *Specification* to the *Commentary*. This simplified provision provides a conservative approximation to the distortional buckling stress,  $F_d$ , for C- and Z-sections with simple lip stiffeners. The expressions were specifically derived as a conservative



simplification to those provided in *Specification* Sections C4.2(a) and (b). For many common sections the simplified provision may be used to show that distortional buckling of the column will not control the capacity. *Specification* provisions C4.2(a) or (b), however, should be used to obtain the distortional buckling strength [resistance] if distortional buckling controls the design.

*Simplified Method for Unrestrained C- and Z-Sections with Simple Lip Stiffeners*

For C- and Z-sections that have no rotational restraint of the flange and that are within the dimensional limits provided in this section, Equation C-C4.2-1 can be used to calculate a conservative prediction of distortional buckling stress,  $F_d$ . See *Specification* Section C4.2(a) or C4.2(b) for alternative provisions and for members outside the dimensional limits.

The following dimensional limits should apply:

- (1)  $50 \leq h_o/t \leq 200$ ,
- (2)  $25 \leq b_o/t \leq 100$ ,
- (3)  $6.25 < D/t \leq 50$ ,
- (4)  $45^\circ \leq \theta \leq 90^\circ$ ,
- (5)  $2 \leq h_o/b_o \leq 8$ , and
- (6)  $0.04 \leq D \sin\theta/b_o \leq 0.5$ .

where

$h_o$  = Out-to-out *web* depth as defined in *Specification* Figure B2.3-2

$b_o$  = Out-to-out flange width as defined in *Specification* Figure B2.3-2

$D$  = Out-to-out lip dimension as defined in *Specification* Figure B4-1

$t$  = Base steel *thickness*

$\theta$  = Lip angle as defined in *Specification* Figure B4-1

The distortional buckling stress,  $F_d$ , can be calculated in accordance with Eq. C-C4.2-1:

$$F_d = \alpha k_d \frac{\pi^2 E}{12(1-\mu^2)} \left( \frac{t}{b_o} \right)^2 \quad (\text{C-C4.2-1})$$

where

$\alpha$  = A value that accounts for the benefit of an unbraced length,  $L_m$ , shorter than  $L_{cr}$ , but can be conservatively taken as 1.0

$$= 1.0 \quad \text{for } L_m \geq L_{cr}$$

$$= (L_m/L_{cr})^{\ln(L_m/L_{cr})} \quad \text{for } L_m < L_{cr} \quad (\text{C-C4.2-2})$$

where

$L_m$  = Distance between discrete restraints that restrict distortional buckling (for continuously restrained members  $L_m = L_{cr}$ , but the restraint can be included as a rotational spring,  $k_\phi$ , in accordance with the provisions in *Specification* Section C4.2 (a) or (b))

$$L_{cr} = 1.2 h_o \left( \frac{b_o D \sin\theta}{h_o t} \right)^{0.6} \leq 10 h_o \quad (\text{C-C4.2-3})$$

$$k_d = 0.05 \leq 0.1 \left( \frac{b_o D \sin \theta}{h_o t} \right)^{1.4} \leq 8.0 \quad (\text{C-C4.2-4})$$

$E$  = Modulus of elasticity of steel

$\mu$  = Poisson's ratio

Equations C-C4.2-1 to C-C4.2-4 assume the compression flange is unrestrained; however, the methods of *Specification* Sections C4.2(a) and (b) allow for a rotational restraint,  $k_\phi$ , to be included to account for attachments which restrict flange rotation. Additional guidance on  $k_\phi$  is provided in the *Commentary* Section C3.1.4.

(a) *For C- and Z-Sections or Hat Sections or Any Open Section with Stiffened Flanges of Equal Dimension where the Stiffener is either a Simple Lip or a Complex Edge Stiffener*

The provisions of *Specification* Section C4.2(a) provide a general method for calculation of the distortional buckling stress,  $F_d$ , for any open section with equal edge stiffened compression flanges, including those with complex edge stiffeners. The provisions of *Specification* Section C4.2(a) also provide a more refined answer for any C- and Z-section including those meeting the dimensional criteria of the *Simplified Provision for Unrestrained C- and Z-Sections with Simple Lip Stiffeners* presented in this commentary. The expressions employed here are derived in Schafer (2002) and verified for complex stiffeners in Schafer et al. (2006). The equations used for the distortional buckling stress,  $F_d$ , in AS/NZS 4600 are also similar to those in *Specification* Section C4.2(a), except that when the web is very slender and is restrained by the flange, AS/NZS 4600 uses a simpler, conservative treatment. Since the provided expressions can be complicated, solutions for the geometric properties of C- and Z-sections based on centerline dimensions are provided in Table C-C3.1.4(a)-1.

(b) *Rational Elastic Buckling Analysis*

Rational elastic buckling analysis consists of any method following the principles of mechanics to arrive at an accurate prediction of the elastic distortional buckling stress. It is important to note that this is a rational elastic buckling analysis and not simply an arbitrary rational method to determine strength. A variety of rational computational and analytical methods can provide the elastic buckling moment with a high degree of accuracy. Complete details are provided in Section 1.1.2 of the *Commentary* to Appendix 1 of the *Specification*. The safety and resistance factors of this section have been shown to apply to a wide variety of cross-sections undergoing distortional buckling (via the methods of Appendix 1). As long as the member falls within the geometric limits of main *Specification* Section B1.1 the same safety and resistance factors have been assumed to apply.

## CHANGES AND UPDATES IN CHAPTER D, STRUCTURAL ASSEMBLIES AND SYSTEMS

1. On page 101, add the following to the end of the 5th paragraph “To avoid confusion for different design methods, the minimum required strength of the inter-connection changed to 2.5 percent of the available strength of the built-up member.”
2. Add the following two figures to page 104 before item (b):

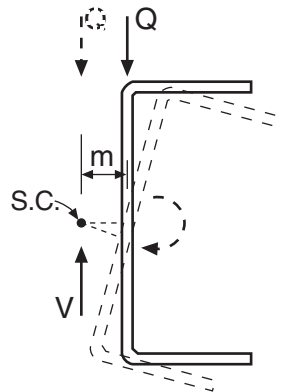

**Figure C-D3.2.1-1 Rotation of C-Section Beams**

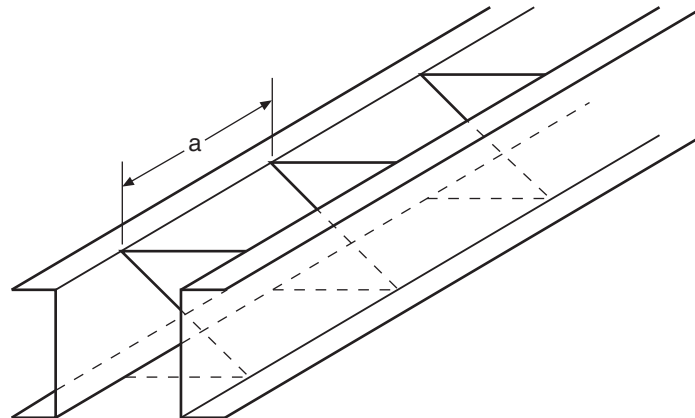

**Figure C-D3.2.1-2 Two C-Sections Braced at Intervals Against Each Other**

3. On page 110, replace  
 “See Appendix A for commentary on the country specific standards. ➡ A “  
 with the following:  
 (e) The *North American Standard for Cold-Formed Steel Framing – Lateral Design (Lateral Standard)* addresses the design of lateral force resisting systems to resist wind and seismic forces in a wide range of buildings constructed with cold-formed steel framing. Use of the *Lateral Standard* is mandatory for the design and installation of cold-formed steel light-framed shear walls, diagonal strap bracing (that is part of a structural wall) and diaphragms to resist

wind, seismic and other in-plane lateral loads because certain requirements, such as design requirements specific to shear walls and diaphragms sheathed with wood structural panels, gypsum board, fiberboard and steel sheet, as well as special seismic requirements for these and systems using diagonal strap bracing are not adequately addressed by the *Specification*.

4. On page 112, on the third line of the second paragraph, change “1992” to “1982<sup>1</sup>” and add the following footnote to “1882”:

<sup>1</sup> In 2010, the reference to Department of Army, 1992 edition was reverted back to 1982 edition due to errors that are related to deck design found in the 1992 edition.

Also on the first line of page 113, change “1992” to “1982”.

5. Add the followings to the end of Section D1.3:

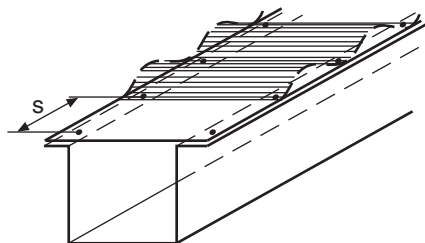

**Figure C-D1.3-1 Spacing of Connectors in Composite Section**

*Specification* Section B2.5 extends the limits of this section and uses the post buckling strength of the edge stiffened compression plate. *Specification* Section B2.5 specifies the parameter ranges that are validated by the research. (Luttrell and Balaji, 1992; Snow and Easterling, 2008).

## **CHANGES AND UPDATES IN COMMENTARY ON CHAPTER E, CONNECTIONS AND JOINTS**

Replace the whole chapter with the followings:

### **E. CONNECTIONS AND JOINTS**

#### **E1 General Provisions**

Welds, bolts, screws, rivets, and other special devices such as metal stitching and adhesives are generally used for cold-formed steel connections (Brockenbrough, 1995). The 2007 edition of the *Specification* contains provisions in Chapter E for welded connections, bolted connections, and screw connections. Among the above three commonly used types of connections, the design provisions for using screws were developed in 1993 and were included in the 1996 AISI *Specification* for the first time. The following brief discussions deal with the applications of rivets and other special devices:

(a) *Rivets*

While hot rivets have little application in cold-formed steel construction, cold rivets find considerable use, particularly in special forms, such as blind rivets (for application from one side only), tubular rivets (to increase bearing area), high shear rivets, and explosive rivets. For the design of connections using cold rivets, the provisions for bolted connections may be used as a general guide, except that the shear strength [resistance] of rivets may be quite different from that of bolts. Additional design information on the strength [resistance] of rivets should be obtained from manufacturers or from tests.

(b) *Special devices*

Special devices include: (1) metal stitching, achieved by tools that are special developments of the common office stapler, and (2) connecting by means of special clinching tools that draw the sheets into interlocking projections.

Most of these connections are proprietary devices for which information on strength [resistance] of connections must be obtained from manufacturers or from tests carried out by or for the user. Guidelines provided in *Specification* Chapter F are to be used in these tests.

The plans and/or specifications are to contain adequate information and design requirement data for the adequate detailing of each connection if the connection is not detailed on the engineering design drawings.

In this edition of the *Specification*, the ASD, LRFD and LSD design provisions for welded and bolted connections were based on the 1996 edition of the *AISI Specification* with some revisions and additions which will be discussed in subsequent sections.

## **E2 Welded Connections**

Welds used for cold-formed steel construction may be classified as fusion welds (or arc welds) and resistance welds. Fusion welding is used for connecting cold-formed steel members to each other as well as connecting such members to heavy, hot-rolled steel framing (such as floor panels to beams of the steel frame). It is used in groove welds, arc spot welds, arc seam welds, fillet welds, and flare groove welds.

The design provisions contained in this *Specification* section for fusion welds have been based primarily on experimental evidence obtained from an extensive test program conducted at Cornell University. The results of this program are reported by Pekoz and McGuire (1979) and summarized by Yu (2000). All possible failure modes are covered in the *Specification* since 1996, whereas the earlier *Specification* mainly dealt with shear failure.

For most of the connection tests reported by Pekoz and McGuire (1979), the onset of yielding was either poorly defined or followed closely by failure. Therefore, in the provisions of this section, rupture rather than yielding is used as a more reliable criterion of failure.

The welded connection tests, which served as the basis of the provisions given in *Specification* Sections E2.1 through E2.5, were conducted on sections with single and double sheets. See *Specification* Figures E2.2-1 and E2.2-2. The largest total sheet thickness of the cover plates was approximately 0.15 inch (3.81 mm). However, within this *Specification*, the validity of the equations was extended to welded connections in which the thickness of the thinnest connected part is 3/16 inch (4.76 mm) or less. For arc spot welds, the maximum thickness of a

single sheet (*Specification* Figure E2.2.2.1-1) and the combined thickness of double sheets (*Specification* Figure E2.2.2.1-2) are set at 0.15 inch (3.81 mm).

In 2001, the safety factors and resistance factors in this section were modified for consistency based on the research work by Tangorra, Schuster, and LaBoube (2001).

For design tables and example problems on welded connections, see Part IV of the *Design Manual* (AISI, 2008).

See Appendix A or B for additional commentary.

→ **A,B**

### **E2.1 Groove Welds in Butt Joints**

The design equations for determining nominal strength [resistance] for groove welds in butt joints have been taken from the AISC LRFD Specification (AISC, 1993). Therefore, the AISC definition for the effective throat thickness,  $t_e$ , is equally applicable to this section of the *Specification*. Prequalified joint details are given in AWS D1.3-98 (AWS, 1998) or other equivalent weld standards.

In 2010, *Specification* Section E2.1(a) was revised to delete the case for tension or compression parallel to the axis of the weld, so that *Specification* Equation E2.1-1 is applicable only to tension or compression normal to the effective area of the weld. For tension or compression parallel to the weld axis, the computation of the weld strength is not required (AISC, 2005).

### **E2.2 Arc Spot Welds**

Arc spot welds (puddle welds) used for connecting thin sheets are similar to plug welds used for relatively thicker plates. The difference between plug welds and arc spot welds is that the former are made with prepunched holes, but for the latter no prepunched holes are required. Instead, a hole is burned in the top sheet by the arc and then filled with weld metal to fuse it to the bottom sheet or a framing member. The provisions of Section E2.2 apply to plug welds as well as spot welds.

#### **E2.2.1 Minimum Edge and End Distance**

In the 2001 and 2007 editions of the *Specification*, the distance measured in the line of force from the centerline of weld to the nearest edge of an adjacent weld or to the end of the connected part toward which the force is directed was required to not be less than  $e_{\min}$  which is equal to required strength (factored force) divided by  $(F_u t)$ . In 2010, an equivalent resistance is determined by the use of Section E5.1.

## E2.2.2 Shear

### E2.2.2.1 Shear Strength [Resistance] for Sheet(s) Welded to a Thicker Supporting Member

The Cornell tests (Pekoz and McGuire, 1979) identified four modes of failure for arc spot welds, which are addressed in this *Specification* section. They are: (1) shear failure of welds in the fused area, (2) tearing of the sheet along the contour of the weld with the tearing spreading the sheet at the leading edge of the weld, (3) sheet tearing combined with buckling near the trailing edge of the weld, and (4) shearing of the sheet behind the weld. It should be noted that many failures, particularly those of the plate tearing type, may be preceded or accompanied by considerable inelastic out-of-plane deformation of the type indicated in Figure C-E2.2.2.1-1. This form of behavior is similar to that observed in wide, pin-connected plates. Such behavior should be avoided by closer spacing of welds. When arc spot welds are used to connect two sheets to a framing member as shown in *Specification* Figure E2.2.2.1-2, consideration should also be given to the possible shear failure between thin sheets.

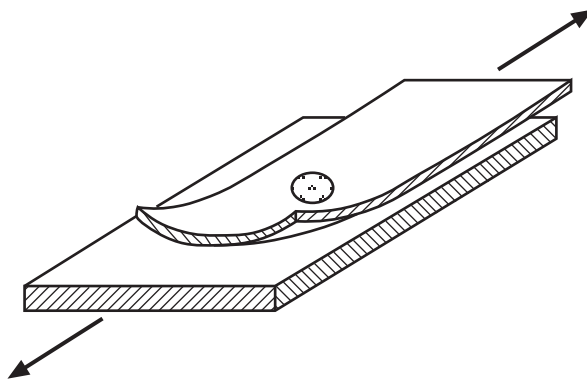

**Figure C-E2.2.2.1-1 Out of Plane Distortion of Welded Connection**

The thickness limitation of 0.15 inch (3.81 mm) is due to the range of the test program that served as the basis of these provisions. On sheets below 0.028 inch (0.711 mm) thick, weld washers are required to avoid excessive burning of the sheets and, therefore, inferior quality welds.

In the AISI 1996 *Specification*, Equation E2.2-1 was revised to be consistent with the research report (Pekoz and McGuire, 1979).

In 2001, the equation used for determining  $d_a$  for multiple sheets was revised to be (d-t).

### E2.2.2.2 Shear Strength [Resistance] for Sheet-to-Sheet Connections

The Steel Deck Institute Design Manual (SDI, 1987) stipulates that the shear strength for a sheet-to-sheet arc spot weld connection be taken as 75% of the strength of a sheet-to-structural connection. SDI further stipulates that the sheet-to-structural connection strength [resistance] be defined by *Specification* Equation E2.2.2.1-2. This design provision was adopted by the *Specification* in 2004. Prior to accepting the SDI design recommendation, a review of the pertinent research by Luttrell (SDI, 1987) was performed by LaBoube (LaBoube, 2001). The test data thickness range that is reflected in the *Specification* documents the scope of Luttrell's test program. SDI suggests that sheet-

to-sheet welds are problematic for thickness less than 0.0295 in. (0.75 mm). Such welds result in “blow holes” but the perimeter must be fused to be effective.

Quality control for sheet-to-sheet connections is not within the purview of AWS D1.3. However, using AWS D1.3 as a guide, the following quality control/assurance guidelines are suggested:

- (1) Measure the visible diameter of the weld face,
- (2) Ensure no cracks in the welds,
- (3) Maximum undercut = 1/8 of the weld circumference, and
- (4) Sheets are to be in contact with each other.

### **E2.2.3 Tension**

For tensile capacity of arc spot welds, the design provisions in the 1989 Addendum were based on the tests reported by Fung (1978) and the study made by Albrecht (1988). Those provisions were limited to sheet failure with restrictive limitations on material properties and sheet thickness. These design criteria were revised in 1996 because the tests conducted at the University of Missouri-Rolla (LaBoube and Yu, 1991 and 1993) have shown that two potential limit states may occur. The most common failure mode is that of sheet tearing around the perimeter of the weld. This failure condition was found to be influenced by the sheet thickness, the average weld diameter, and the material tensile strength. In some cases, it was found that tensile failure of the weld can occur. The strength [resistance] of the weld was determined to be a function of the cross-section of the fused area and tensile strength of the weld material. Based on analysis by LaBoube (LaBoube, 2001), the nominal strength [resistance] equation was changed in 2001 to reflect the ductility of the sheet,  $F_u/F_y$ , and the sheet thickness, the average weld diameter, and the material tensile strength.

The multiple safety factors and resistance factors recognize the behavior of a panel system with many connections versus the behavior of a member connection and the potential for a catastrophic failure in each application. In *Specification* Section E2.2.3 a target reliability index of 3.0 for the United States and Mexico and 3.5 for Canada is used for the panel connection limit, whereas a target reliability index of 3.5 for the United States and Mexico and 4 for Canada is used for the other connection limit. Precedence for the use of a smaller target reliability index for systems was established in Section D6.2.1 of the *Specification*.

Tests (LaBoube and Yu, 1991 and 1993) have also shown that when reinforced by a weld washer, thin sheet weld connections can achieve the design strength [resistance] given by *Specification* Equation E2.2.3-2 using the thickness of the thinner sheet.

The equations given in the *Specification* were derived from the tests for which the applied tension load imposed a concentric load on the weld, as would be the case, for example, for the interior welds on a roof system subjected to wind uplift. Welds on the perimeter of a roof or floor system would experience an eccentric tensile loading due to wind uplift. Tests have shown that as much as a 50 percent reduction in nominal connection strength [resistance] could occur because of the eccentric load application (LaBoube and Yu, 1991 and 1993). Eccentric conditions may also occur at connection laps depicted by Figure C-E2.2.3-1.



At a lap connection between two deck sections as shown in Figure C-E2.2.3-1, the length of the unstiffened flange and the extent of the encroachment of the weld into the unstiffened flange have a measurable influence on the strength [resistance] of the welded connection (LaBoube and Yu, 1991). The *Specification* recognizes the reduced capacity of this connection detail by imposing a 30 percent reduction on the calculated nominal strength [resistance].

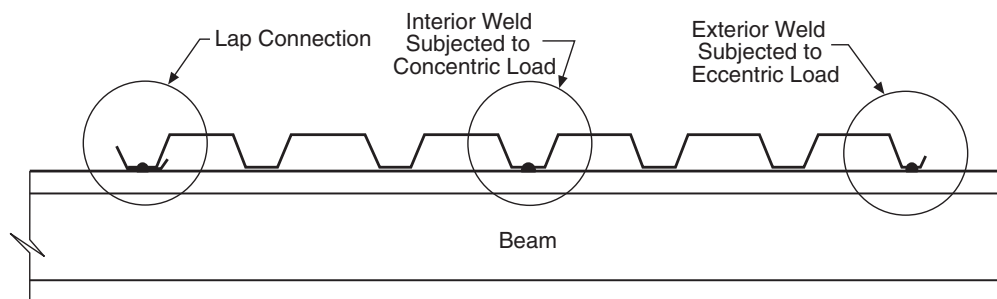

**Figure C-E2.2.3-1 Interior Weld, Exterior Weld and Lap Connection**

### **E2.2.4 Combined Shear and Tension on an Arc Spot Weld**

The Steel Deck Institute Diaphragm Design Manual (2004) provides a design equation for the evaluating the strength of an arc spot weld connection subject to combined shear and tension forces. An experimental investigation was conducted at the University of Missouri – Rolla to study the behavior and to develop design recommendations for the relationship (interaction) of the tension and shear forces on an arc spot weld connection (Stirnermann, LaBoube, 2007).

The experimental study focused on six variables that were deemed to be the key parameters that may influence the strength of the arc spot weld connection. These variables were the sheet thickness; sheet material properties including yield strength, tensile strength and ductility of the sheet; visible diameter of the arc spot weld; and the relationship between the magnitude of the shear force and tension force. Based on an analysis of the test results, the Steel Deck Institute’s interaction equation was found to provide an acceptable estimate of the strength [resistance] of the arc spot weld connection.

## **E2.3 Arc Seam Welds**

The general behavior of arc seam welds is similar to that of arc spot welds. In 2010, Section E2.3 has been reorganized to be consistent with provisions provided for arc spot welds.

### **E2.3.2 Shear**

#### **E2.3.2.1 Shear Strength [Resistance] for Sheet(s) Welded to a Thicker Supporting Member**

No simple shear failures of arc seam welds were observed in the Cornell tests (Pekoz and McGuire, 1979). Therefore, *Specification* Equation E2.3.2.1-1, which accounts for shear failure of welds, is adopted from the AWS welding provisions for sheet steel (AWS, 1998).

*Specification* Equation E2.3.2.1-2 is intended to prevent failure by a combination of tensile tearing plus shearing of the cover plates.

### E2.3.2.2 Shear Strength [Resistance] for Sheet-to-Sheet Connections

In 2010, the provisions for determining the shear strength [resistance] of sheet-to-sheet arc spot weld connections were adopted for arc seam weld connections. This is conservative because the length of the seam weld is not considered.

## E2.4 Fillet Welds

For fillet welds on the lap joint specimens tested in the Cornell research (Pekoz and McGuire, 1979), the dimension,  $w_1$ , of the leg on the sheet edge generally was equal to the sheet thickness; the other leg,  $w_2$ , often was two or three times longer than  $w_1$  (See *Specification* Figure E2.4-1). In connections of this type, the fillet weld throat commonly is larger than the throat of a conventional fillet welds of the same size. Usually ultimate failure of fillet welded joints has been found to occur by the tearing of the plate adjacent to the weld, See Figure C-E2.4-1.

In most cases, the higher strength of the weld material prevents weld shear failure, therefore, the provisions of this *Specification* section are based on sheet tearing. Because specimens up to 0.15 inch (3.81 mm) thickness were tested in the Cornell research (Pekoz and McGuire, 1979), the last provision in this section is to cover the possibility that for sections thicker than 0.15 inch (3.81 mm), the throat dimension may be less than the thickness of the cover plate and the tear may occur in the weld rather than in the plate material. Additional research at the University of Sydney (Zhao and Hancock, 1995) has further indicated that weld throat failure may even occur between the thickness of 0.10 in. (2.54 mm) to 0.15 in. (3.81 mm). Accordingly, the *Specification* was revised, in 2001, to require weld strength [resistance] check when the plate thickness is greater than 0.10 in. (2.54 mm). For high strength materials with yield stress of 65 ksi (448 MPa) or higher, research at the University of Sydney (Teh and Hancock, 2000) has shown that weld throat failure does not occur in materials less than 0.10 in. (2.54 mm) thick and that the *AISI Specification* provisions based on sheet strength are satisfactory for high strength material less than 0.10 in. (2.54 mm) thick. Prequalified fillet welds are given in AWS D1.3-98 (AWS, 1998) or other equivalent weld

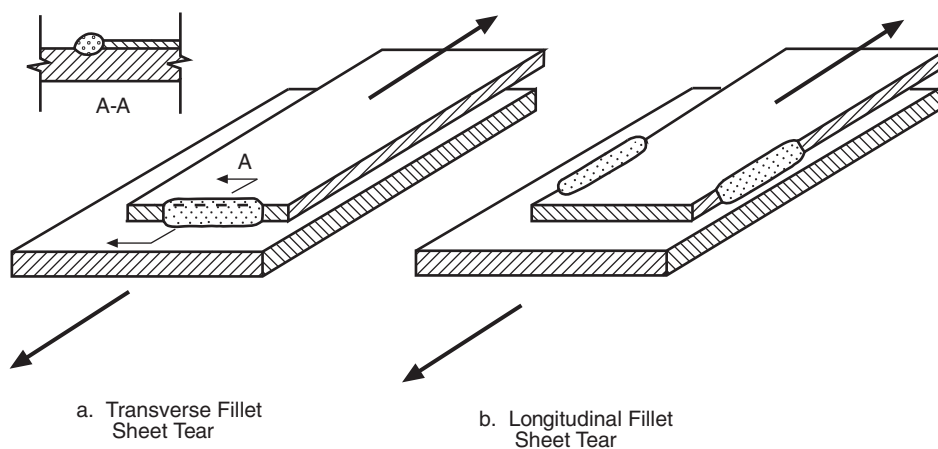
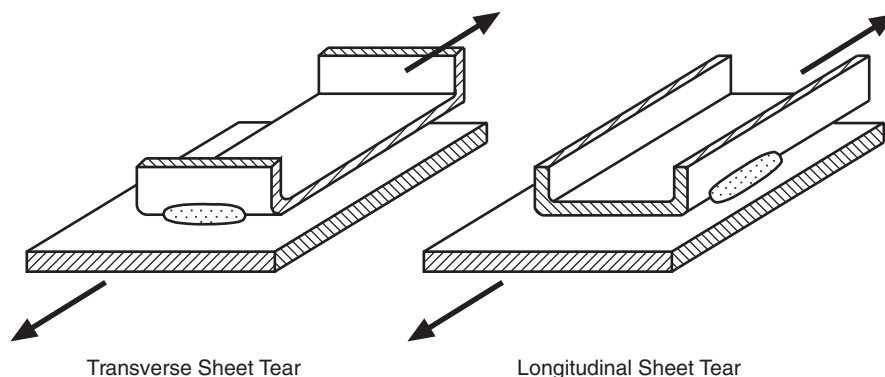

**Figure C-E2.4-1 Fillet Weld Failure Modes**

standards.

## E2.5 Flare Groove Welds

The primary mode of failure in cold-formed steel sections welded by flare groove welds, loaded transversely or longitudinally, also was found to be sheet tearing along the contour of the weld. See Figure C-E2.5-1.



**Figure C-E2.5-1 Flare Groove Weld Failure Modes**

Except for *Specification* Equation E2.5-4, the provisions of this *Specification* section are intended to prevent shear tear failure. *Specification* Equation E2.5-4 covers the possibility that thicker sections may have effective throats less than the thickness of the channel and weld failure may become critical.

In 2001, the *Specification* was revised to require that weld strength be checked when the plate thickness is greater than 0.10 in. (2.54 mm) based on the research by Zhao and Hancock (1995).

In 2010, the former *Specification* Figures E2.5-4 through E2.5-7 were replaced by two new drawings showing reference dimensions for flare bevel groove welds and flare V-groove welds respectively. *Specification* Equations E2.5-5 and E2.5-7 were added to more accurately define the effective throat of these welds. Filled flush throat depths were modified to match those specified in AWS D1.1-2006 Section 2.3.1.4 and Table 2.1. Welding Process designations in *Specification* Tables E2.5-1 and E2.5-2 were based on AWS D1.1 Annex K, where SMAW stands for "shielded metal arc welding", FCAW-S stands for "flux cored arc welding-self shielded", GMAW stands for "gas metal arc welding", FCAW-G stands for "flux cored arc welding-gas shielded", and SAW stands for "submerged arc welding". No change was needed in the *Specification* requirements from previous editions except in the definitions of the effective throat for use in *Specification* Equation E2.5-4.

## E2.6 Resistance Welds

The shear values for outside sheets of 0.125 inch (3.18 mm) or less in thickness are based on "Recommended Practice for Resistance Welding Coated Low-Carbon Steels," AWS C1.3-70, (Table 2.1 - Spot Welding Galvanized Low-Carbon Steel). Shear values for outside sheets thicker than 0.125 inch (3.18 mm) are based upon "Recommended Practices for Resistance Welding," AWS C1.1-66, (Table 1.3 - Pulsation Welding Low-Carbon Steel) and apply to pulsation welding as well as spot welding. They are applicable for all structural grades of low-carbon steel, uncoated or galvanized with 0.90 oz/ft<sup>2</sup> (275 g/m<sup>2</sup>) of sheet, or less, and are

based on values selected from AWS C1.3-70, Table 2.1; and AWS C1.1-66, Table 1.3. The above values may also be applied to medium carbon and low-alloy steels. Spot welds in such steels give somewhat higher shear strengths than those upon which the above values are based; however, they may require special welding conditions. In view of the fact that AWS C1.1-66 and AWS C1.3-70 Standards were incorporated in AWS C1.1-2000, resistance welds should be performed in accordance with AWS C1.1-2000 (AWS, 2000).

In the 2001 edition and this edition of the *Specification*, a design equation is used to determine the nominal shear strength [resistance] that replaces the tabulated values given in the previous specifications. The upper limit of *Specification* Equations E2.6-1, E2.6-3 and E2.6-5 is selected to best fit the data provided in AWS C1.3-70, Table 2.1 and AWS C1.1-66, Table 1.3. Shear strength [resistance] values for welds with the thickness of the thinnest outside sheet greater than 0.180 in. (4.57 mm) have been excluded in *Specification* Equations E2.6-2, E2.6-4 and E2.6-6 due to the thickness limit set forth in *Specification* Section E2.

### E3 Bolted Connections

The structural behavior of bolted connections in cold-formed steel construction is somewhat different from that in hot-rolled heavy construction, mainly because of the thinness of the connected parts. Prior to 1980, the provisions included in the *AISI Specification* for the design of bolted connections were developed on the basis of the Cornell tests (Winter, 1956a, 1956b). These provisions were updated in 1980 to reflect the results of additional research performed in the United States (Yu, 1982) and to provide a better coordination with the specifications of the Research Council on Structural Connections (RCSC, 1980) and AISC (1978). In 1986, design provisions for maximum size of bolt holes and the allowable tension stress for bolts were added in the *AISI Specification* (AISI, 1986). In the 1996 edition of the *AISI Specification*, minor changes of the safety factors were made for computing the allowable and design tensile and shear strengths [resistances] of bolts. The allowable tension stress for the bolts subject to the combination of shear and tension was determined by the equations provided in *Specification* Table E3.4-2 with the applicable safety factor.

#### (a) Scope

Previous studies and practical experiences have indicated that the structural behavior of bolted connections used for joining *relatively thick* cold-formed steel members is similar to that for connecting hot-rolled shapes and built-up members. The *AISI Specification* criteria are applicable only to cold-formed steel members or elements 3/16 inch (4.76 mm) or less in thickness. For materials greater than 3/16 inch (4.76 mm), reference is made to the specifications or standards stipulated in Section E3a of Appendix A or B.

Because of lack of appropriate test data and the use of numerous surface conditions, this *Specification* does not provide design criteria for slip-critical (also called friction-type) connections. When such connections are used with cold-formed members where the thickness of the thinnest connected part is 3/16 inch (4.76 mm) or less, it is recommended that tests be conducted to confirm their design capacity. The test data should verify that the specified design capacity for the connection provides a sufficient safety against initial slip at least equal to that implied by the provisions of the specifications or standards listed in Section E3a of Appendix A or B. In addition, the safety against ultimate capacity should be at least equal to that implied by this *Specification* for bearing-type connections.

The *Specification* provisions apply only when there are no gaps between plies. The designer should recognize that the connection of a rectangular tubular member by means of bolt(s) through such members may have less strength [resistance] than if no gap existed. Structural performance of connections containing unavoidable gaps between plies would require tests in accordance with *Specification* Section F1.

(b) *Materials*

This section lists five different types of fasteners which are normally used for cold-formed steel construction. In view of the fact that A325 and A490 bolts are available only for diameters of 1/2 inch (12.7 mm) and larger, A449 and A354 Grade BD bolts should be used as an equivalent of A325 and A490 bolts, respectively, whenever smaller bolts (less than 1/2 inch (12.7 mm) in diameter) are required.

During recent years, other types of fasteners, with or without special washers, have been widely used in steel structures using cold-formed steel members. The design of these fasteners should be determined by tests in accordance with Chapter F of this *Specification*.

(c) *Bolt Installation*

Bolted connections in cold-formed steel structures use either mild or high-strength steel bolts and are designed as a bearing-type connection. Bolt pretensioning is not required because the ultimate strength of a bolted connection is independent of the level of bolt preload. Installation must ensure that the bolted assembly will not come apart during service. Experience has shown that bolts installed to a snug tight condition do not loosen or “back-off” under normal building conditions and are not subject to vibration or fatigue.

Bolts in slip-critical connections, however, must be tightened in a manner which assures the development of the fastener tension forces required by the Research Council on Structural Connections (1985 and 2000) for the particular size and type of bolts. Turn-of-nut rotations specified by the Research Council on Structural Connections may not be applicable because such rotations are based on larger grip lengths than are encountered in usual cold-formed construction. Reduced turn-of-the-nut values would have to be established for the actual combination of grip and bolt. A similar test program (RCSC, 1985 and 1988) could establish a cut-off value for calibrated wrenches. Direct tension indicators (ASTM F959), whose published clamping forces are independent of grip, can be used for tightening slip-critical connections.

(d) *Hole Sizes*

Design information for oversized and slotted holes is included in the Appendices because such holes are often used in practice to meet dimensional tolerances during erection. ➔ **A.B**

An exception to the provisions for slotted holes is made in the case of slotted holes in lapped and nested zees. Resistance is provided in this situation partially by the nested components, rather than direct bolt shear and bearing. An oversize or slotted hole is required for proper fit-up due to offsets inherent in nested parts. Research (Bryant and Murray, 2001) has shown that lapped and nested zee members with 1/2 in. (12.7 mm) diameter bolts without washers and 9/16 in. x 7/8 in. (14.3 mm x 22.2 mm) slotted holes in the direction of stress can develop the full moment in the lap.

### **E3.3 Bearing**

Previous bolted connection tests have shown that the bearing strength [resistance] of bolted connections depends on (1) the tensile strength  $F_u$  of the connected parts, (2) the thickness of connected parts, (3) the diameter of bolt, (4) joints with single shear and double shear conditions, (5) the  $F_u/F_y$  ratio, and (6) the use of washers (Winter, 1956a and 1956b; Chong and Matlock, 1974; Yu, 1982 and 2000). These design parameters were used in the 1996 and earlier editions of the *AISI Specification* for determining the bearing strength [resistance] between bolt and connected parts (AISI, 1996).

In the Canadian Standard (CSA, 1994), the  $d/t$  ratio was also used in the design equation for determining the bearing strength [resistance] of bolted connections.

#### **E3.3.1 Strength [Resistance] Without Consideration of Bolt Hole Deformation**

Rogers and Hancock (Rogers and Hancock, 1998) developed the design equation for bearing of bolted connections with washers (*Specification* Table E3.3.1-1). Based on research at the University of Waterloo (Wallace, Schuster, and LaBoube, 2001a), the Rogers and Hancock equation was extended to bolted connections without washers and to the inside sheet of double shear connections with or without washers (*Specification* Table E3.3.1-2). In *Specification* Table E3.3.1-1, the bearing factor  $C$  depends on the ratio of bolt diameter to member thickness,  $d/t$ . The design equations in the *Specification* Section E3.3.1 are based on available test data. Thus, for sheets thinner than 0.024 in. (0.61 mm), tests must be performed to determine the structural performance.

The safety factor and resistance factor are based on calibration of available test data (Wallace, Schuster, and LaBoube, 2001b).

#### **E3.3.2 Strength [Resistance] With Consideration of Bolt Hole Deformation**

Based on research at the University of Missouri-Rolla (LaBoube and Yu, 1995), design equations have been developed that recognize the presence of hole elongation prior to reaching the limited bearing strength [resistance] of a bolted connection. The researchers adopted an elongation of 0.25 in. (6.4 mm) as the acceptable deformation limit. This limit is consistent with the permitted elongation prescribed for hot-rolled steel.

Since the nominal strength [resistance] value with consideration of bolt hole deformation should not exceed the nominal strength [resistance] without consideration of the hole deformation, this limit was added in 2004.

### **E3.4 Shear and Tension in Bolts**

The design provisions of this section are given in Section E3.4 of Appendix A or B. In Appendix A, the commentary is provided for Section E3.4.



## E4 Screw Connections

Results of over 3500 tests worldwide were analyzed to formulate screw connection provisions (Pekoz, 1990). European Recommendations (1987) and British Standards (1992) were considered and modified as appropriate. Since the provisions apply to many different screw connections and fastener details, a greater degree of conservatism is implied than is otherwise typical within this *Specification*. These provisions are intended for use when a sufficient number of test results are not available for the particular application. A higher degree of accuracy can be obtained by testing any particular connection geometry (AISI, 1992).

Over 450 elemental connection tests and eight diaphragm tests were conducted in which compressible fiberglass insulation, typical of that used in metal building roof systems (MBMA, 2002), was placed between the two pieces of steel (between steel sheet samples in the elemental connection tests and between the deck and purlin in the diaphragm tests) (Lease and Easterling, 2006a, 2006b). The results indicate that the equations in Section E4 of the *Specification* are valid for applications that incorporate 6-3/8 in. (162 mm) or less of compressible fiberglass insulation.

Screw connection tests used to formulate the provisions included single fastener specimens as well as multiple fastener specimens. However, it is recommended that at least two screws should be used to connect individual elements. This provides redundancy against under-torquing, over-torquing, etc., and limits lap shear connection distortion of flat unformed members such as straps.

Proper installation of screws is important to achieve satisfactory performance. Power tools with adjustable torque controls and driving depth limitations are usually used.

For the convenience of designers, Table C-E4-1 gives the correlation between the common number designation and the nominal diameter for screws. See Figure C-E4-1 for the measurement of nominal diameters.

**Table C-E4-1 Nominal Diameter for Screws**

Number Designation	Nominal Diameter, d	
	in.	mm
0	0.060	1.52
1	0.073	1.85
2	0.086	2.18
3	0.099	2.51
4	0.112	2.84
5	0.125	3.18
6	0.138	3.51
7	0.151	3.84
8	0.164	4.17
10	0.190	4.83
12	0.216	5.49
1/4	0.250	6.35



**Figure C-E4-1 Nominal Diameter for Screws**

### E4.1 Minimum Spacing

Minimum Spacing is the same as specified for bolts.

### E4.2 Minimum Edge and End Distances

In 2001, the minimum edge distance was decreased from  $3d$  to  $1.5d$ .

### E4.3 Shear

#### E4.3.1 Shear Strength [Resistance] Limited by Tilting and Bearing

Screw connections loaded in shear can fail in one mode or in combination of several modes. These modes are screw shear, edge tearing, tilting and subsequent pull-out of the screw, and bearing of the joined materials.

Tilting of the screw followed by threads tearing out of the lower sheet reduces the connection shear capacity from that of the typical connection bearing strength (Figure C-E4.3-1).

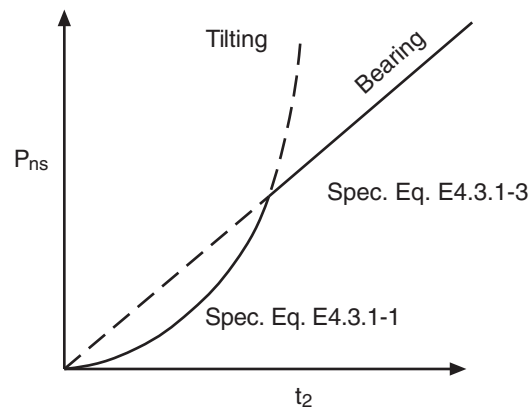

**Figure C-E4.3-1 Comparison of Tilting and Bearing**

These provisions are focused on the tilting and bearing failure modes. Two cases are given depending on the ratio of thicknesses of the connected members. Normally, the head of the screw will be in contact with the thinner material as shown in Figure C-E4.3-2. However, when both members are the same thickness, or when the thicker member is in contact with the screw head, tilting must also be considered as shown in Figure C-E4.3-3.

It is necessary to determine the lower bearing capacity of the two members based on the product of their respective thicknesses and tensile strengths.

#### E4.3.2 Shear in Screws

Shear strength [resistance] of the screw fastener itself should be known and documented from testing. Screw strength should be established and published by the manufacturer. In order to prevent the brittle and sudden shear fracture of the screw, the *Specification* applies a 25 percent adjustment to the safety factor or the resistance factor where determined in accordance with *Specification* Section F1.



#### **E4.4 Tension**

Screw connections loaded in tension can fail either by pulling out of the screw from the plate (pull-out) or pulling of material over the screw head and the washer, if a washer is present, (pull-over) or by tensile fracture of the screw. The serviceability concerns of gross distortion are not covered by the equations given in *Specification* Section E4.4.

Diameter and rigidity of the fastener head assembly as well as sheet thickness and tensile strength have a significant effect on the pull-over failure load of a connection.

There are a variety of washers and head styles in use. Washers must be at least 0.050 inch (1.27 mm) thick to withstand bending forces with little or no deformation. In 2010, the minimum washer thickness requirement was relaxed for the washers in connections where  $t_1$  does not exceed 0.027 in. (0.69 mm), with the evidence that the washer thickness of as low as 0.024 in. (0.61 mm) does not adversely impact the pull-over strength of the connection for such top substrate thicknesses (Mujagic 2008).

##### **E4.4.1 Pull-Out Strength [Resistance]**

For the limit state of pull-out, *Specification* Equation E4.4.1-1 was derived on the basis of the modified European Recommendations and the results of a large number of tests. The statistic data on pull-out design considerations were presented by Pekoz (1990).

##### **E4.4.2 Pull-Over Strength [Resistance]**

For the limit state of pull-over, *Specification* Equation E4.4.2-1 was derived on the basis of the modified British Standard and the results of a series of tests as reported by Pekoz (1990). In 2007, a rational allowance was included to cover the contribution of steel washers beneath screw heads. For the special case of screws with domed washers, that is washers that are not solid or do not seat flatly against the sheet metal in contact with the washer, the calculated nominal pull-over strength [resistance] should not exceed  $1.5t_1d'_wF_{u1}$  with  $d'_w = 5/8$  in. (16 mm). The 5/8 in. (16 mm) limit does not apply to solid steel washers in full contact with the sheet metal. In accordance with *Specification* Section E4, testing is allowed as an alternative method to determine fastener capacity. To use test data in design, the tested material should be consistent with the design. When a polygon shaped washer is used and capacity is determined using *Specification* Equation E4.4.2-1, the washer should have rounded corners to prevent premature tearing.

In 2010, the pancake head washer screws and domed washers integral with the screw head were added and defined to assist the designer in proper determination of computational variables.

##### **E4.4.3 Tension in Screws**

Tensile strength [resistance] of the screw fastener itself should be known and documented from testing. Screw strength [resistance] should be established and published by the manufacturer. In order to prevent the brittle and sudden tensile fracture of the screw, the *Specification* applies a 25 percent adjustment to the safety factor or the resistance factor where determined in accordance with Section F1.

#### E4.5 Combined Shear and Pull-Over

Research pertaining to the behavior of a screw connection has been conducted at West Virginia University (Luttrell, 1999). Based on a review and analysis of West Virginia University's data for the behavior of a screw connection subject to combined shear and tension (Zwick and LaBoube, 2002), equations were derived that enable the evaluation of the strength of a screw connection when subjected to combined shear and tension. The tests indicated that at failure the sheet beneath the screw head pulled over the head of the screw or the washer. Therefore, the nominal tensile strength is based solely on  $P_{nov}$ . Although both non-linear and linear equations were developed, for ease of computation and because the linear equation provides regions of  $Q/P_{ns}$  and  $T/P_{nov}$  equal to unity, the linear equation was adopted for the *Specification*. The proposed equation is based on the following test program limits:

$$0.0285 \text{ in. (0.724 mm)} \leq t_1 \leq 0.0445 \text{ in. (1.13 mm)}$$

No. 12 and No. 14 self-drilling screws with or without washers

$$d_w \leq 0.75 \text{ in. (19.1 mm)}$$

$$62 \text{ ksi (427 MPa or 4360 kg/cm}^2\text{)} \leq F_{u1} \leq 70.7 \text{ ksi (487 MPa or 4970 kg/cm}^2\text{)}$$

$$t_2 / t_1 \geq 2.5$$

The limit  $t_2 / t_1 \geq 2.5$  reflects the fact that the test program (Luttrell, 1999) focused on connections having sheet thicknesses that precluded the tilting limit state from occurring. Thus, this limit ensures that the design equations will only be used when tilting limit state is not the control limit state.

The linear form of the equation as adopted by the *Specification* is similar to the following more conservative linear design equation that has been used by engineers:

$$Q/P_{ns} + T/P_{nov} \leq 1.0$$

An eccentric load on a clip connection may create a non-uniform stress distribution around the fastener. For example, tension tests on roof panel welded connections have shown that under an eccentrically applied tension force the resulting connection capacity is 50% of the tension capacity under a uniformly applied tension force. Thus, the *Specification* stipulates that the pull-over strength [resistance] shall be taken as 50% of  $P_{nov}$ . If the eccentric load is applied by a rigid member such as a clip, the resulting tension force on the screw may be uniform, thus the force in the screw can be determined by mechanics and the capacity of the fastener should be reliably estimated by  $P_{nov}$ . Based on the field performance of screw attached panels, the 30 percent reduction associated with welds at sidelaps need not be applied when evaluating the strength of sidelap screw connections at supports or sheet to sheet. The reduction is due to transverse prying or peeling. It is acceptable to apply the 50 percent reduction at panel ends due to longitudinal prying.

#### E5 Rupture

The provisions contained in *Specification* Section E5 and its subsections are applicable only when the thinnest connected part is 3/16 inch (4.76 mm) or less in thickness. For materials thicker than 3/16 inch (4.76 mm), the design should follow the specifications or standards stipulated in *Specification* Section E5a of Appendix A or B. ➔ **B**

Significant changes were made to the format of *Specification* Section E5 in 2010. Connections

may be subject to shear rupture, tension rupture, block failure in tension, block failure, or any combinations of these failures in shear depending upon the relationship of the connectors to the connection geometry and loading direction. *Specification* Table E5.2-1 provides adjustment factors consistent with prior editions of the *Specification* to cover shear lag factors. Other adjustment factors provide allowances for staggered connector patterns and non-uniform stress distribution on the tensile plane.

(a) *Shear Lag for Flat Sheet Connections*

Previous tests showed that for flat sheet connections using a single bolt or a single row having multiple bolts perpendicular to the force (Chong and Matlock, 1975; Carill, LaBoube and Yu, 1994), the joint rotation and out-of-plane deformation of flat sheets are excessive. The strength reduction due to tearing of steel sheets in the net section is considered by *Specification* Equations E5.2-4, E5.2-5, and E5.2-6 contained in Table E5.2-1 according to the  $d/s$  ratio and the use of washers (AISI, 1996; Fox and Schuster, 2007). For flat sheet connections using multiple connectors in the line of force and having less out-of-plane deformations, the strength reduction is not required in this edition of the *Specification* (Rogers and Hancock, 1998).

(b) *Staggered Holes*

The presence of staggered or diagonal hole patterns in a bolted connection has long been recognized as increasing the net section area for the limit state of rupture in the net section. LaBoube and Yu (1995) summarized the findings of a limited study of the behavior of bolted connections having staggered hole patterns. The research showed that when a staggered hole pattern is present, the width of a rupture plane can be adjusted by use of  $s^2/4g$ . The critical tensile path involving stagger has been reduced by 10%. This reduction is justified on the basis of the research by LaBoube and Yu (1995).

(c) *Shear Lag for Other Than Flat Sheet Connections*

Shear lag has a debilitating effect on the tensile capacity of a cross section. Based on UMR research (LaBoube and Yu, 1995) design equations have been developed that can be used to estimate the influence of the shear lag. The research demonstrated that the shear lag effect differs for an angle and a channel. For both cross sections, however, the key parameters that influence shear lag are the distance from the shear plane to the center of gravity of the cross section and the length of the connection (Figures C-E5-1 and C-E5-2). The research showed that for cold-formed steel sections using single bolt connections, bearing usually controlled the nominal strength [resistance], not rupture in the net section.

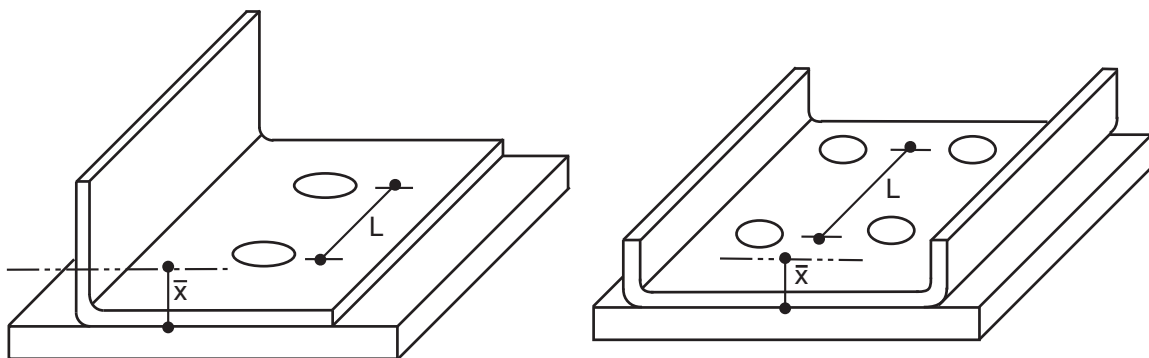

**Figure C-E5-1**  $\bar{x}$  Definition for Sections with Bolted Connections

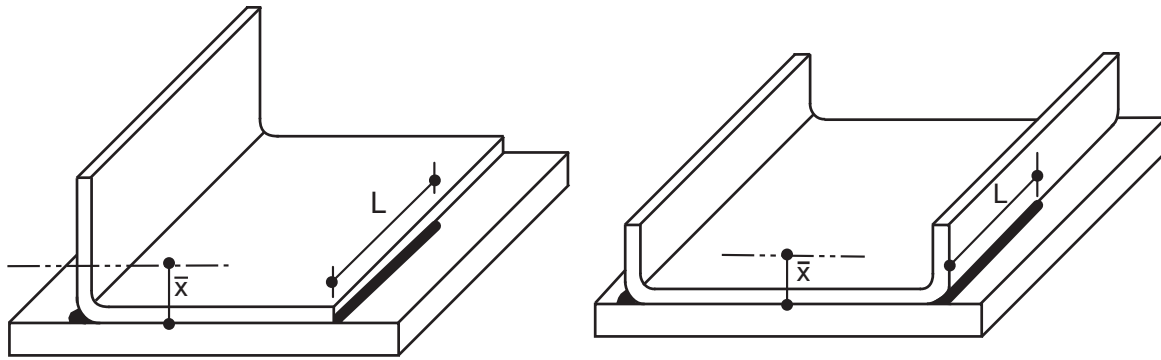

**Figure C-E5-2**  $\bar{x}$  Definition for Sections with Fillet Welding

*(d) Block Shear*

Block shear is a limit state in which the resistance is determined by the sum of the shear strength [resistance] on a failure path(s) parallel to the force and the tensile strength [resistance] on the segment(s) perpendicular to the force. A comprehensive test program does not exist regarding block shear for cold-formed steel members. However, a limited study conducted at the University of Missouri-Rolla indicates that the AISC equations may be applied to cold-formed steel members.

Block shear is a rupture or tearing phenomenon, not a yielding limit state. However, gross yielding on the shear plane can occur when tearing on the tensile plane. *Specification* Equations E5.3-1 and E5.3-2 check both conditions.

Connection tests conducted by Birkemoe and Gilmor (1978) have shown that on coped beams a tearing failure mode as shown in Figure C-E5-5 can occur along the perimeter of the holes. Hardash and Bjorhovde (1985) have demonstrated these effects for tension members as illustrated in Figure C-E5-4. The summary paper “AISC LRFD Rules for Block Shear in Bolted Connections – A Review” (Kulak and Grondin, 2001) provides a summary of test data for block shear rupture strength [resistance].

The distribution of tensile stresses is not always uniform (Ricles and Yura, 1983; Kulak and Grondin, 2001). For shear forces on coped beams, an additional multiplier,  $U_{bs}$ , of 0.5 is used when more than one row of bolts is present. This approach is consistent with the provisions of the ANSI/AISC 360 (AISC, 2005).

Tests performed at the University at Missouri-Rolla have indicated that the current design equations for shear and tilting provide a reasonably good estimate of the connection performance for multiple screws in a pattern (LaBoube and Sokol, 2002).

Examples of failure paths can be found in Figures C-E5-3 through C-E5-7.

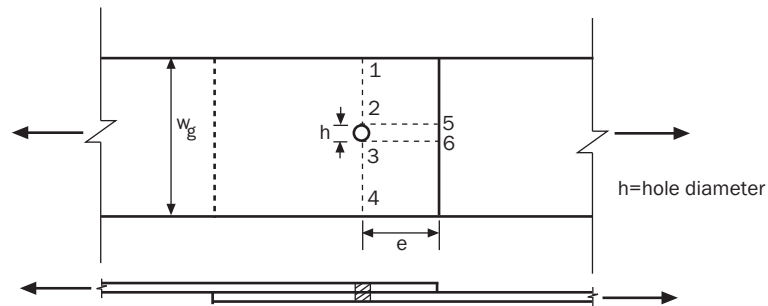

**Figure C-E5-3 Potential Failure Paths of Single Lap Joint**

(Tension Failure)

Failure Path 1, 2, 3, 4

*Specification* Section E5.2 applies

$$A_e = U_{sl} U_{st} A_{nt}$$

$U_{sl}$  in accordance with *Specification* Equations E5.2-4, E5.2-5, or E5.2-6

$$U_{st} = 1.0$$

$$A_{nt} = (w_g - h) t$$

(Shear Failure)

Failure Path 5, 2, 3, 6

*Specification* Section E5.1 applies

$$A_{nv} = 2n(e - 1/2h) t$$

$n = 1$  as there is only a single fastener

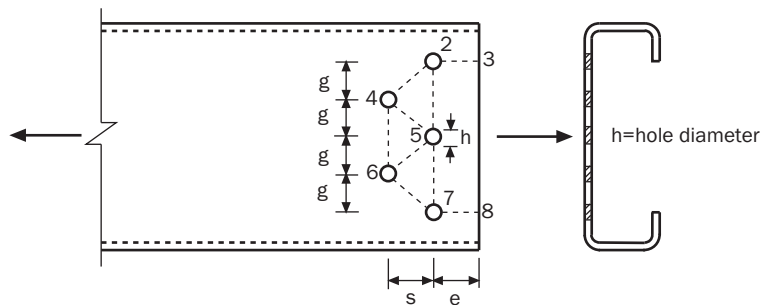

**Figure C-E5-4 Potential Failure Paths of Stiffened Channel (Block Shear)**

Failure Path 3, 2, 4, 5, 6, 7, 8

*Specification* Section E5.3 applies

$$A_{gv} = 2et$$

$$A_{nv} = 2(e - 1/2h) t$$

$$A_{nt} = 4(g + s^2/4g - h) t$$

$$U_{st} = 0.9$$

$$U_{bs} = 1.0$$

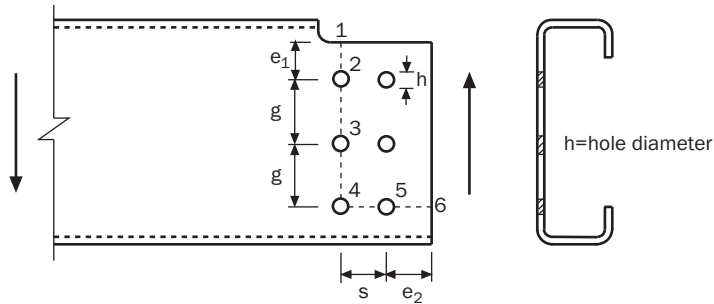

**Figure C-E5-5 Potential Failure Path of Coped Stiffened Channel (Block Shear)**

Failure Path 1, 2, 3, 4, 5, 6

*Specification* Section E5.3 applies

$$A_{gv} = (2g + e_1) t$$

$$A_{nv} = A_{gv} - 2.5ht$$

$$A_{nt} = [(s + e_2) - 1.5h] t$$

$$U_{st} = 1.0$$

$$U_{bs} = 0.5$$

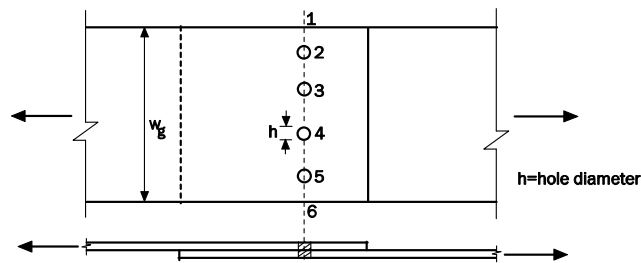

**Figure C-E5-6 Potential Failure Path of Multiple Fastener Lap Joint (Tension)**

Failure Path 1, 2, 3, 4, 5, 6

*Specification* Section E5.2 applies

$$A_e = U_{sl} U_{st} A_{nt}$$

$U_{sl}$  in accordance with *Specification* Eq. E5.2-4, E5.2-5, or E5.2-6

$$U_{st} = 1.0$$

$$A_{nt} = (w_g - 4h) t$$

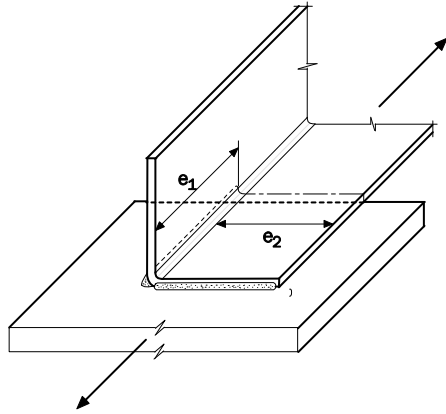

**Figure C-E5-7 Potential Failure Path of Fillet Welded Joint**

*Specification* Section E5.2 applies

$$U_{sl} = 1.0 - 1.20 x / e_1 \leq 0.9 \quad (\text{Specification Eq. E5.2-7})$$

$$U_{st} = 1.0$$

## **E6 Connections to Other Materials**

### **E6.1 Bearing**

The design provisions for the nominal bearing strength [resistance] on the other materials should be derived from appropriate material specifications.

### **E6.2 Tension**

This section is included in the *Specification* to raise the awareness of the design engineer regarding tension on fasteners and the connected parts.

### **E6.3 Shear**

This section is included in the *Specification* to raise the awareness of the design engineer regarding the transfer of shear forces from steel components to adjacent components of other materials.

## CHANGES AND UPDATES IN COMMENTARY ON CHAPTER F, TESTS FOR SPECIAL CASES

1. Replace Section F1.1 as follows:

### F1.1 Load and Resistance Factor Design and Limit States Design

The determination of load-carrying capacity of the tested elements, assemblies, connections, or members is based on the same procedures used to calibrate the LRFD design criteria, for which the  $\phi$  factor can be computed from Equation C-A5.1.1-15. The correction factor  $C_P$  is used in *Specification* Equation F1.1-2 for determining the  $\phi$  factor to account for the influence due to a small number of tests (Pekoz and Hall, 1988b and Tsai, 1992). It should be noted that when the number of tests is large enough, the effect of the correction factor is negligible. In the 1996 edition of the *AISI Specification*, Equation F1.1-3 was revised because the old formula for  $C_P$  could be unconservative for combinations of a high  $V_P$  and a small sample size (Tsai, 1992). This revision enables the reduction of the minimum number of tests from four to three identical specimens. Consequently, the  $\pm 10$  percent deviation limit was relaxed to  $\pm 15$  percent. The use of  $C_P$  with a minimum  $V_P$  reduces the need for this restriction. In *Specification* Equation F1.1-3, a numerical value of  $C_P = 5.7$  was found for  $n = 3$  by comparison with a two-parameter method developed by Tsai (1992). It is based on the given value of  $V_Q$  and other statistics listed in *Specification* Table F1, assuming that  $V_P$  will be no larger than about 0.20. The requirements of *Specification* Section F1.1(a) for  $n = 3$  help to ensure this.

The 6.5 percent minimum value of  $V_P$ , when used in *Specification* Equation F1.1-2 for the case of three tests, produces safety factors similar to those of the 1986 edition of the *AISI ASD Specification*, i.e. approximately 2.0 for members and 2.5 for connections. The LRFD calibration reported by Hsiao, Yu and Galambos (1988a) indicates that  $V_P$  is almost always greater than 0.065 for common cold-formed steel components, and can sometimes reach values of 0.20 or more. The minimum value for  $V_P$  helps to prevent potential unconservatism compared to values of  $V_P$  implied in LRFD design criteria.

In evaluating the coefficient of variation  $V_P$  from test data, care must be taken to use the coefficient of variation for a sample. This can be calculated as follows:

$$V_P = \frac{\sqrt{s^2}}{R_m} \quad \text{C-F1.1-1}$$

where

$s^2$  = sample variance of all test results

$$= \frac{1}{n-1} \sum_{i=1}^n (R_i - R_m)^2 \quad \text{C-F1.1-2}$$

$R_m$  = mean of all test results

$R_i$  = test result  $i$  of  $n$  total results

Alternatively,  $V_P$  can be calculated as the sample standard deviation of  $n$  ratios  $R_i/R_m$ .

In 2010, *Specification* Section F1.1 was modified to recognize that the behavior and probability of failure for a composite interior partition wall stud differs from the direct load bearing system. A composite interior wall stud is a stud in an interior application with full-



height gypsum sheathing that is screw attached to both flanges and supports no axial load other than self-weight. The maximum permitted nominal lateral loads for composite design are stipulated in *Specification* Section F1.1. There is typically no dead load perpendicular to the wall. In the United States, these lateral loads are defined as live loads, thus, for LRFD the applicable load combination is 1.6L.

Traditional ASD practice for composite interior partition wall studs has employed an  $\Omega = 1.5$ . For acceptable levels of variability (i.e., reasonably low  $V_p$ ) this corresponds to a  $\beta_o = 1.6$  (for LRFD and LSD with  $M_m = 1.10$ ,  $V_m = 0.10$ ,  $F_m = 1.00$  and  $V_F = 0.05$ ). Note, for these lower levels of reliability,  $\phi$  calculated per *Specification* Equation F1.1-2 may be greater than 1.0. A  $\phi$  greater than 1.0 (just like a  $\phi$  less than 1.0) simply reflects the necessary change in the nominal strength such that the target reliability is achieved.

Calibration of  $\beta_o$  to past practice reflects that for composite interior partition wall studs, as defined in *Specification* F1.1, the consequences of failure are less severe than for other structural members. In addition, the  $\beta_o$  of *Specification* Section F1.1 is calculated for a 50 year return period. Based on occupancy statistics, average tenancy is 8 years (Galambos and Ellingwood 1986). The traditional 50 year  $\beta_o$  may be converted to an 8 year time period via Equation C-F1.1-3:

$$\beta_{8\text{yr}} = -\Phi^{-1} [\Phi(-\beta_o) (8/50)] \quad \text{C-F1.1-3}$$

where  $\Phi$  is the cumulative distribution function (CDF) of the standard normal distribution. For  $\beta_o = 1.6$  using Equation C-F1.1-3,  $\beta_{8\text{yr}} = 2.4$  which provides a more accurate assessment of the reliability of the wall over its expected service life.

These provisions only apply to the case of determining the strength of composite interior partition wall studs as defined in *Specification* Section F1.1 through tests. Where an all steel design is used, the provisions of *Specification* Section D4 apply.

For beams having tension flange through-fastened to deck or sheathing and with compression flange laterally unbraced (subject to wind uplift), the calibration is based on a load combination of 1.17W-0.9D with  $D/W = 0.1$  (see Section D6.1.1 of this *Commentary* for detailed discussion).

The statistical data needed for the determination of the resistance factor are listed in *Specification* Table F1. The data listed for screw connections were added in 1996 on the basis of the study of bolted connections reported by Rang, Galambos, and Yu (1979b). The same statistical data of  $M_m$ ,  $V_m$ ,  $F_m$  and  $V_F$  have been used by Pekoz in the development of the design criteria for screw connections (Pekoz, 1990).

In 1999, two entries were added to Table F1, one for "Structural Members Not Listed Above" and the other for "Connections Not Listed Above". It was considered necessary to include these values for members and connections not covered by one of the existing classifications. The statistical values were taken as the most conservative values in the existing table.

In 2004, the statistic data  $V_M$  for screw bearing strength was revised from 0.10 to 0.08. This revision is based on the tensile strength statistic data provided in the UMR research report (Rang, Galambos, and Yu, 1979b). In addition,  $V_f$  was revised from 0.10 to 0.05 to reflect the tolerance of the cross-sectional area of the screw.

In 2007, additional entries were made to Table F1 to provide statistical data for all limit states included within the *Specification* for the standard connection types. The entry

“Connections Not Listed Above” is intended to provide statistical data for connections other than welded, bolted, or screwed.

Also In 2007, the *Specification* more clearly defined the appropriate material properties that are to be used when evaluating test results by specifying that supplier provided properties are not to be used.

The *Specification* provides methods for determining the deflection of some members for serviceability consideration, but the *Specification* does not provide serviceability limits. Justification is discussed in Section A8 of the *Commentary*.

**CHANGES AND UPDATES IN APPENDIX 1**

1. On page 1-4, replace the last paragraph with the followings:

“It is intended that as more cross-sections are verified for use in the Direct Strength Method, these tables and sections will be augmented. Companies with proprietary sections may wish to perform their own testing and follow Chapter F of the main *Specification* to justify the use of the pre-qualified  $\Omega$  and  $\phi$  factors for a particular cross-section. When such testing is performed the provisions of *Specification* Section 1.1.1.1 provide some relief from the sample size correction factor,  $C_P$ , of *Specification* Chapter F. Based on the existing data the largest observed  $V_P$  for the pre-qualified categories is 15% (Schafer 2006, 2008). Therefore, as long as the tested section, over at least three tests, exhibits a  $V_P < 15\%$  then the section is assumed to be similar to the much larger database of tested sections used to calibrate the Direct Strength Method and the correction for small sample sizes  $C_P$  is not required and therefore is set to 1.0. If the  $\phi$  generated from *Specification* Chapter F is higher than that of Section 1.2.1 of Appendix 1, this is evidence that the section behaves as a pre-qualified section. It is not anticipated that member testing is necessarily required for all relevant limit states: local, distortional and global buckling. An engineer may only require testing to reflect a single common condition for the member, with a minimum of three tests in that condition. However, beams and columns should be treated as separate entities. A manufacturer who cannot establish a common condition for a product may choose to perform testing in each of the limit states to ensure reliable performance in any condition. Engineering judgment is required. Note that for the purposes of this section, the test results in *Specification* Chapter F are replaced by test to predicted ratios. The prediction is that of the Direct Strength Method (this Appendix) using the actual material and cross-sectional properties from the tests. The  $P_m$  parameter, taken as equal to one in *Specification* Chapter F, is taken instead as the mean of the test-to-predicted ratios, and  $V_P$  is the accompanying coefficient of variation. Alternatively, member geometries that are not pre-qualified may still use the method of Appendix 1, but with the increased  $\Omega$  and reduced  $\phi$  factors consistent with any rational analysis method as prescribed in A1.2 of the main *Specification*.”

2. On page 1-4, insert the following as the second paragraph in Section 1.1.1.2:

For beams that do not meet the material and geometric requirements defined by the pre-qualified categories, similar to column design, provisions are provided to potentially permit those members to use the  $\Omega$  and  $\phi$  factors of the pre-qualified members by using *Specification* Chapter F as discussed in detail in commentary section 1.1.1.1 above.

## UPDATE OF REFERENCES

Add the following references

- Galambos, T.V., Ellingwood, B. (1986). "Serviceability Limit States: Deflection." ASCE, *Journal of Structural Engineering*, 112 (1) 67-84.
- Jones, M. L., and LaBoube, R. A., and Yu, W. W. (1997), "Spacing of Connections in Compression Elements for Cold-Formed Steel Members," Summary Report, Civil Engineering Study 97-6, University of Missouri-Rolla, MO December 1997.
- Luttrell L.D. and Balaji, K. (1992), "Properties of Cellular Decks in Negative Bending," Proceedings of the 11<sup>th</sup> International Specialty Conference on Cold- Formed Steel Structures, University of Missouri - Rolla, Rolla, MO 1992
- Mujagic, J.R.U. (2008), "Effect of Washer Thickness on the Pull-over Strength of Screw Connections Covered under AISI S100-2007 Chapter E," Wei-Wen Yu Center for Cold-Formed Steel Structures, Rolla, MO, 2008.
- Schafer, B.W. (2009). "Improvement to AISI Section B5.1.1 for Effective Width of Elements with Intermediate Stiffeners." CCFSS Technical Bulletin, February 2009.
- Schafer, B. W. (2008). "Review: The Direct Strength Method of cold-formed steel member design." *Journal of Constructional Steel Research*, 64 (7/8) 766-778, 2008.
- Schafer, B. W. (2006). "Direct Strength Method Design Guide." CF06-1, American Iron and Steel Institute, Washington, D.C., 2006.
- Schafer, B.W., Trestain, T. (2002). "Interim Design Rules for Flexure in Cold-Formed Steel Webs." *Proceedings of the Sixteenth International Specialty Conference on Cold-Formed Steel Structures*, Orlando, FL. 145-160.
- Snow, G. L. and Easterling, W. S. (2008). "Section Properties for Cellular Decks Subjected to Negative Bending." Report No. CE/VPI - 08/06. Virginia Polytechnic Institute and State University, Blacksburg, VA, 88 pages.
- Steel Deck Institute, Inc. (2004), *Steel Deck Institute Diaphragm Design Manual*, Third Edition, Fox River Grove, IL, 2004
- Stirnemann, L.K., R. A. LaBoube (2007), Behavior of Arc Spot Weld Connections Subjected to Combined Shear and Tension Forces, Research Report, University of Missouri-Rolla, Rolla, MO, 2007
- Yu, C., Schafer, B.W. (2003). "Local Buckling Tests on Cold-Formed Steel Beams." ASCE, *Journal of Structural Engineering*. 129 (12) 1596-1606.

## CHANGES AND UPDATES IN COMMENTARY ON APPENDIX A

1. Delete Section C2.
2. Delete Section D4.
4. Replace all the sections starting from E2a with the followings:

### **E2a Welded Connections**

The upper limit of the *Specification* applicability was revised in 2004 from 0.18 in. (4.57 mm) to 3/16 in. (4.76 mm). This change was made to be consistent with the limit given in the AWS D1.3 (1998).

The design provisions for welded connections were developed based primarily on experimental evidence obtained from an extensive test program conducted at Cornell University. In addition, the Cornell research provided the experimental basis for the AWS Structural Welding Code for Sheet Steel (AWS, 1998). In most cases, the provisions of the AWS code are in agreement with this *Specification* section.

The terms used in this *Specification* section agree with the standard nomenclature given in the AWS Welding Structural Code for Sheet Steel (AWS, 1998).

For welded material thicknesses greater than 3/16 in. (4.76 mm), AISC Specification (2005) should be followed.

### **E3a Bolted Connections**

In Table E3a of Appendix A, the maximum size of holes for bolts having diameters not less than 1/2 inch (12.7 mm) is based on the specifications of the Research Council on Structural Connections and the American Institute of Steel Construction (RCSC, 2000 and 2004; AISC, 1989, 1999, and 2005), except that for the oversized hole diameter, a slightly larger hole diameter is permitted.

For bolts having diameters less than 1/2 inch (12.7 mm), the diameter of a standard hole is the diameter of bolt plus 1/32 inch (0.794 mm). This maximum size of bolt holes is based on previous editions of the *AISI Specification*.

When using oversized holes care must be exercised by the designer to ensure that excessive deformation due to slip will not occur at working loads. Excessive deformations which can occur in the direction of the slots may be prevented by requiring bolt pretensioning.

Short-slotted holes are usually treated in the same manner as oversized holes. Washers or backup plates should be used over oversized or short-slotted holes in an outer ply unless suitable performance is demonstrated by tests. For connections using long-slotted holes, *Specification* Section E3 requires the use of washers or back-up plates and that the shear capacity of bolts be determined by tests because a reduction in strength may be encountered.

### **E3.4 Shear and Tension in Bolts**

For the design of bolted connections, the allowable shear stresses for bolts have been provided in the *AISI Specification* for cold-formed steel design since 1956. However, the allowable tension stresses were not provided in *Specification* Section E3.4 for bolts subject to tension until 1986. In *Specification* Table E3.4-1, the allowable stresses specified for A307 ( $d \geq 1/2$  inch (12.7 mm)), A325, and A490 bolts were based on Section 1.5.2.1 of the AISC

Specification (1978). It should be noted that the same values were also used in Table J3.2 of the AISC ASD Specification (1989). For A307, A449, and A354 bolts with diameters less than 1/2-inch (12.7 mm), the allowable tension stresses were reduced by 10 percent, as compared with these bolts having diameters not less than 1/2 inch (12.7 mm), because the average ratio of (tensile-stress area)/(gross-area) for 1/4-inch (6.35 mm) and 3/8-inch (9.53 mm) diameter bolts is 0.68, which is about 10 percent less than the average area ratio of 0.75 for 1/2-inch (12.7 mm) and 1-inch (25.4 mm) diameter bolts. In the AISI ASD/LRFD *Specification* (1996), Table E3.4-1 provided nominal tensile strengths for various types of bolts with applicable safety factors. The allowable tension stresses computed from  $F_{nt}/\Omega$  were approximately the same as that permitted by the AISI 1986 ASD *Specification*. The same table also gave the resistance factor to be used for the LRFD method.

The design provisions for bolts subjected to a combination of shear and tension were added in AISI *Specification* Section E3.4 in 1986. Those design equations were based on Section 1.6.3 of the AISC Specification (AISC, 1978) for the design of bolts used for bearing-type connections.

In 1996, tables which listed the equations for determining the reduced nominal tension stress,  $F'_{nt}$ , for bolts subjected to the combination of shear and tension were included in the *Specification* and were retained in the 2001 edition. In 2007, those tables were replaced by *Specification* Equations E3.4-2 and E3.4-3 to determine the reduced tension stress of bolts subjected to the combined tension and shear. *Specification* Equations E3.4-2 and E3.4-3 were adopted to be consistent with the AISC Specification (AISC, 2005).

Note that when the required stress,  $f$ , in either shear or tension, is less than or equal to 20 per cent of the corresponding available stress, the effects of combined stress need not be investigated.

For bolted connection design, the possibility of pullover of the connected sheet at the bolt head, nut, or washer should also be considered when bolt tension is involved, especially for thin sheathing material. For unsymmetrical sections, such as C- and Z-sections used as purlins or girts, the problem is more severe because of the prying action resulting from rotation of the member which occurs as a consequence of loading normal to the sheathing. The designer should refer to applicable product code approvals, product specifications, other literature, or tests.

For design tables and example problems on bolted connections, see Part IV of the *Design Manual* (AISI, 2008).

## **CHANGES AND UPDATES IN COMMENTARY ON APPENDIX B**

1. Replace Section E2a with the followings:

### **E2a Welded Connections**

The section has been revised and expanded and replaces Clause 7.2 of CSA Standard S136-94. See *Commentary* for detailed information. Both fabricators and erectors must be certified under CSA Standard W47.1 for arc welding and CSA Standard W55.3 for resistance welding. This provision extends the certification requirements to the welding of cold-formed members or components to other construction, e.g., welding steel deck to structural steel framing.

### **E3 Bolted Connections**

#### **E3.3 Bearing**

Improvements have been made to this section in comparison to Clause 7.3.5.1 of CSA Standard S136-94. Section E3.3.2 has been added, giving consideration to bolt hole deformation. See *Commentary* for detailed information.

### **E5a Rupture**

As can be observed in Table E5-1, there is a difference in resistance factors between LSD and LRFD. In Canada, rupture has been traditionally assumed to be a member type failure and not a connection type. Therefore, the resistance factor in Table E5-1 is the same regardless of the type of connector and is consistent with rupture of the net section provisions in Section C2.2. In the USA and Mexico, rupture in Table E5-1 is treated as a connection type of failure with the resulting lower resistance factors.







**American  
Iron and Steel  
Institute**

1140 Connecticut Avenue NW  
Suite 705  
Washington, DC 20036  
**[www.steel.org](http://www.steel.org)**



5060 Spectrum Way  
Suite 100  
Mississauga, Ontario  
Canada  
L4W 5N6  
**[www.cas.ca](http://www.cas.ca)**



Amores 338  
Colonia Del Valle  
Mexico, D.F.  
**[www.canacero.mx](http://www.canacero.mx)**

