

---

CCFSS Library (1939 - present)

Wei-Wen Yu Cold-Formed Steel Library

---

01 Aug 1989

## Load and resistance factor design of cold-formed steel load and resistance factor design specification for cold-formed steel structural members with commentary

Ling-En Hsiao

Wei-Wen Yu

Missouri University of Science and Technology, [wwy4@mst.edu](mailto:wwy4@mst.edu)

Theodore V. Galambos

Follow this and additional works at: <https://scholarsmine.mst.edu/ccfss-library>



Part of the [Structural Engineering Commons](#)

---

### Recommended Citation

Hsiao, Ling-En; Yu, Wei-Wen; and Galambos, Theodore V., "Load and resistance factor design of cold-formed steel load and resistance factor design specification for cold-formed steel structural members with commentary" (1989). *CCFSS Library (1939 - present)*. 142.  
<https://scholarsmine.mst.edu/ccfss-library/142>

This Technical Report is brought to you for free and open access by Scholars' Mine. It has been accepted for inclusion in CCFSS Library (1939 - present) by an authorized administrator of Scholars' Mine. This work is protected by U. S. Copyright Law. Unauthorized use including reproduction for redistribution requires the permission of the copyright holder. For more information, please contact [scholarsmine@mst.edu](mailto:scholarsmine@mst.edu).

**CIVIL ENGINEERING STUDY 89-5  
STRUCTURAL SERIES**

**Twelfth Progress Report**

**LOAD AND RESISTANCE FACTOR DESIGN OF COLD-FORMED STEEL**

**LOAD AND RESISTANCE FACTOR DESIGN SPECIFICATION FOR  
COLD-FORMED STEEL STRUCTURAL MEMBERS WITH COMMENTARY**

by

**Ling-En Hsiao  
Research Assistant  
University of Missouri-Rolla**

**Wei-Wen Yu  
Project Director  
University of Missouri-Rolla**

**Theodore V. Galambos  
Consultant  
University of Minnesota**

**A Research Project Sponsored by the American Iron and Steel Institute**

**August 1989**

**DEPARTMENT OF CIVIL ENGINEERING  
UNIVERSITY OF MISSOURI-ROLLA  
ROLLA, MISSOURI**

## FOREWORD

This progress report contains the following two parts:

Part I: Load and Resistance Factor Design Specification for  
Cold-Formed Steel Structural Members (pp. i-107).

Part II: Commentary on the Load and Resistance Factor Design  
Specification for Cold-Formed Steel Structural Members  
(pp. 109-161).

The load and resistance factor design specification proposed herein is the revised version of the design recommendations prepared in February 1988 and submitted to American Iron and Steel Institute as Tenth Progress Report. This document was prepared according to the 1986 edition of the AISI Specification for the Design of Cold-Formed Steel Structural Members. The selections of  $\phi$  factors are discussed in the Commentary for various types of structural members and connections.

This investigation was sponsored by American Iron and Steel Institute. The technical guidance provided by the AISI Subcommittee on Load and Resistance Factor Design and the AISI Staff is gratefully acknowledged. Members of the AISI Subcommittee are: K. H. Klippstein (Chairman), R. Bjorhovde, D. S. Ellifritt, S. J. Errera, T. V. Galambos, B. Hall, D. H. Hall, R. B. Heagler, N. Iwankiw, A. L. Johnson, D. L. Johnson, A. C. Kuentz, A. S. Nowak, T. B. Pekoz, C. W. Pinkham, R. M. Schuster, and W. W. Yu. Former members of the AISI Task Group on LRFD included R. L. Cary, N. C. Lind, R. B. Matlock, W. Mueller, F. J. Phillips, D. S. Wolford and Late Professor G. Winter.

Special thanks are extended to T. V. Galambos, Consultant of the project, T. N. Rang, B. Supornsilaphachai, B. K. Snyder, L. C. Pan, and M. K. Ravindra for their contributions to the project.

PART I

LOAD AND RESISTANCE FACTOR DESIGN SPECIFICATION  
FOR  
COLD-FORMED STEEL STRUCTURAL MEMBERS

## PREFACE

The AISI allowable stress design specification has long been used for the design of cold-formed steel structural members. The Load and Resistance Factor Design (LRFD) Specification has recently been developed from a research project sponsored by American Iron and Steel Institute. In this LRFD Specification, separate load and resistance factors are applied to specified loads and nominal resistance to ensure that the probability of reaching a limit state is acceptably small. These factors reflect the uncertainties of analysis, design, loading, material properties and fabrication. They are derived on the basis of the first order probabilistic methodology as used for the development of the AISC Load and Resistance Factor Design Specification for Structural Steel Buildings.

This Specification contains six chapters of the LRFD recommendations for cold-formed steel structural members and connections. The background information for the design criteria is discussed in the Commentary and other related references.

TABLE OF CONTENTS

PREFACE..... i

TABLE OF CONTENTS..... ii

SYMBOLS AND DEFINITIONS.....vii

A. GENERAL PROVISIONS..... 1

    A1 Limits of Applicability and Terms..... 1

        A1.1 Scope and Limits of Applicability ..... 1

        A1.2 Terms..... 1

        A1.3 Units of Symbols and Terms..... 4

    A2 Non-Conforming Shapes and Constructions..... 4

    A3 Material..... 4

        A3.1 Applicable Steels..... 4

        A3.2 Other Steels..... 5

        A3.3 Ductility..... 6

        A3.4 Delivered Minimum Thickness..... 8

    A4 Loads..... 8

        A4.1 Dead Load..... 8

        A4.2 Live or Snow Load..... 8

        A4.3 Impact Load..... 8

        A4.4 Wind or Earthquake Load..... 8

        A4.5 Ponding..... 9

    A5 Structural Analysis and Design..... 9

        A5.1 Design Basis..... 9

            A5.1.1 Limit State - Strength..... 9

            A5.1.2 Limit State - Serviceability..... 10

A5.1.3	Nominal Load.....	10
A5.1.4	Load Factors and Load Combinations.....	11
A5.1.5	Resistance Factors.....	12
A5.2	Yield Point and Strength Increase from Cold Work of Forming..	15
A5.2.1	Yield Point.....	15
A5.2.2	Strength Increase from Cold Work of Forming.....	15
A5.3	Durability.....	18
A6	Reference Documents.....	18
B.	ELEMENTS.....	21
B1	Dimensional Limits and Considerations.....	21
B1.1	Flange Flat-Width-to-Thickness Considerations.....	21
B1.2	Maximum Web Depth-to-Thickness Ratio.....	24
B2	Effective Widths of Stiffened Elements.....	24
B2.1	Uniformly Compressed Stiffened Elements.....	24
B2.2	Uniformly Compressed Stiffened Elements with Circular Holes..	27
B2.3	Effective Widths of Webs and Stiffened Elements with Stress Gradient.....	28
B3	Effective Widths of Unstiffened Elements.....	30
B3.1	Uniformly Compressed Unstiffened Elements.....	30
B3.2	Unstiffened Elements and Edge Stiffeners with Stress Gradient.....	31
B4	Effective Widths of Elements with an Edge Stiffener or One Intermediate Stiffener.....	31
B4.1	Uniformly Compressed Elements with an Intermediate Stiffener.	33
B4.2	Uniformly Compressed Elements with an Edge Stiffener.....	34
B5	Effective Widths of Edge Stiffened Elements with Intermediate	



	Stiffeners or Stiffened Elements with More Than One Intermediate Stiffener.....	35
B6	Stiffeners.....	37
	B6.1 Transverse Stiffeners.....	37
	B6.2 Shear Stiffeners.....	38
	B6.3 Non-Conforming Stiffeners.....	39
C.	MEMBERS.....	40
	C1 Properties of Sections.....	40
	C2 Tension Members.....	40
	C3 Flexural Members.....	40
	C3.1 Strength for Bending Only.....	40
	C3.1.1 Nominal Section Strength.....	41
	C3.1.2 Lateral Buckling Strength.....	43
	C3.1.3 Beams Having One Flange Through-Fastened to Deck or Sheathing.....	47
	C3.2 Strength for Shear Only.....	48
	C3.3 Strength for Combined Bending and Shear.....	50
	C3.4 Web Crippling Strength.....	50
	C3.5 Combined Bending and Web Crippling Strength.....	54
	C4 Concentrically Loaded Compression Members.....	55
	C4.1 Sections Not Subject to Torsional or Torsional-Flexural Buckling.....	57
	C4.2 Doubly- or Singly-Symmetric Sections Subject to Torsional or Torsional-Flexural Buckling.....	58
	C4.3 Nonsymmetric Sections.....	58
	C5 Combined Axial Load and Bending.....	58

C6	Cylindrical Tubular Members.....	60
C6.1	Bending.....	60
C6.2	Compression.....	61
C6.3	Combined Bending and Compression.....	62
D.	STRUCTURAL ASSEMBLIES.....	63
D1	Built-Up Sections.....	63
D1.1	I-Sections Composed of Two Channels.....	63
D1.2	Spacing of Connections in Compression Elements.....	65
D2	Mixed Systems.....	66
D3	Lateral Bracing.....	66
D3.1	Symmetrical Beams and Columns.....	66
D3.2	Channel-Section and Z-Section Beams.....	66
D3.2.1	Anchorage of Bracing for Roof Systems Under Gravity Load With Top Flange Connected to Sheathing.....	67
D3.2.2	Neither Flange Connected to Sheathing.....	69
D3.3	Laterally Unbraced Box Beams.....	71
D4	Wall Studs and Wall Stud Assemblies.....	71
D4.1	Wall Studs in Compression.....	72
D4.2	Wall Studs in Bending.....	76
D4.3	Wall Studs with Combined Axial Load and Bending.....	76
E.	CONNECTIONS AND JOINTS.....	77
E1	General Provisions.....	77
E2	Welded Connections.....	77
E2.1	Groove Welds in Butt Joints.....	78
E2.2	Arc Spot Welds.....	79
E2.3	Arc Seam Welds.....	84

E2.4	Fillet Welds.....	85
E2.5	Flare Groove Welds.....	87
E2.6	Resistance Welds.....	89
E3	Bolted Connections.....	89
E3.1	Spacing and Edge Distance.....	91
E3.2	Tension in Connected Part.....	93
E3.3	Bearing.....	94
E3.4	Shear and Tension in Bolts.....	95
E4	Shear Rupture.....	97
E5	Connections to Other Materials.....	98
E5.1	Bearing.....	98
E5.2	Tension.....	99
E5.3	Shear.....	99
F.	TESTS FOR SPECIAL CASES.....	100
F1	Tests for Determining Structural Performance.....	100
F2	Tests for Confirming Structural Performance.....	105
F3	Tests for Determining Mechanical Properties.....	105
F3.1	Full Section.....	105
F3.2	Flat Elements of Formed Sections.....	106
F3.3	Virgin Steel.....	107

## SYMBOLS AND DEFINITIONS

Symbol	Definition	Section
A	Full unreduced cross-sectional area of the member	C3.1.1, C3.1.2, C4, C6.2, D4.1
$A_b$	$b_1 t + A_s$ , for transverse stiffeners at interior support and under concentrated load, and $b_2 t + A_s$ , for transverse stiffeners at end support	B6.1
$A_b$	Gross cross-sectional area of bolt	E3.4
$A_c$	$18t^2 + A_s$ , for transverse stiffeners at interior support and under concentrated load, and $10t^2 + A_s$ , for transverse stiffeners at end support	B6.1
$A_e$	Effective area at the stress $F_n$	C4, C6.2
$A_n$	Net area of cross section	C2, E3.2
$A_s$	Cross-sectional area of transverse stiffeners	B4, B4.1, B4.2, B6.1
$A'_s$	Effective area of stiffener	B4, B4.1, B4.2
$A_{st}$	Gross area of shear stiffener	B6.2
$A_{wn}$	Net web area	E4
$A_1$	Bearing area	E5.1
$A_2$	Full cross sectional area of concrete support	E5.1
a	Shear panel length of the unreinforced web element. For a reinforced web element, the distance between transverse stiffeners	B6.2, C3.2, D3.2
a	Length of bracing interval	D3.2

Symbol	Definition	Section
B	Stud spacing	D4.1
$B_c$	Term for determining the tensile yield point of corners	A5.2.1
b	Effective design width of compression element	B2.1, B2.2, B2.3, B3.1, B3.2, B4.1, B4.2, B5, D3.2.1
$b_d$	Effective width for deflection calculation	B2.1, B2.2
$b_e$	Effective design width of sub-element or element	A1.2, B2.3, B5
$b_o$	See Fig. B4.1	B4, B4.1, B5
C	For flexural members, ratio of the total corner cross-sectional area of the controlling flange to the full cross-sectional area of the controlling flange	A5.2.2
$C_b$	Bending coefficient dependent on moment gradient	C3.1.2
$C_m$	End moment coefficient in interaction formula	C5
$C_{ms}$	Coefficient for lateral bracing of C- and Z-section	D3.2.1
$C_{mx}$	End moment coefficient in interaction formula	C5
$C_{my}$	End moment coefficient in interaction formula	C5
$C_p$	Correction factor	F1
$C_s$	Coefficient for lateral torsional buckling	C3.1.2
$C_{TF}$	End moment coefficient in interaction formula	C3.1.2
$C_{th}$	Coefficient for lateral bracing of C- and Z-section	D3.2.1

Symbol	Definition	Section
$C_{tr}$	Coefficient for lateral bracing of C- and Z-section	D3.2.1
$C_v$	Shear stiffener coefficient	B6.2
$C_w$	Torsional warping constant of the cross-section	C3.1.2
$C_y$	Compression strain factor	C3.1.1
$C_o$	Initial column imperfection	D4.1
$C_1$	Term used to compute shear strain in wall board	B4, B4.1, D4.2
$C_2$	Coefficient as defined in Fig. B4.2	B4, B4.2
$c_f$	Amount of curling	B1.1b
D	Outside diameter of cylindrical tube	C6.1, C6.2, D4.2
D	Overall depth of lip	B1.1, B4, D1.1
D	Shear stiffener coefficient	B6.2
$D_n$	Nominal dead load	A5.1.4
$D_o$	Initial column imperfection	D4.1
d	Depth of section	B1.1b, B4, C3.1.1, D1.1, D3.2.1, D4.1
d	Width of arc seam weld	E2.3
d	Visible diameter of outer surface of arc spot weld	E2.2
d	Diameter of bolt	E3, E3.1, E3.2
$d_a$	Average diameter of the arc spot weld at mid-thickness of t	E2.2

Symbol	Definition	Section
$d_a$	Average width of seam weld	E2.3
$d_e$	Effective diameter of fused area	E2.2
$d_e$	Effective width of arc seam weld at fused surfaces	E2, E2.3
$d_h$	Diameter of standard hole	B2.2, E3.1, E4
$d_s$	Reduced effective width of stiffener	B4, B4.2
$d'_s$	Actual effective width of stiffener	B4, B4.2
$d_{wc}$	Coped web depth	E4
E	Modulus of elasticity of steel ( $29.5 \times 10^3$ ksi)	B1.1b, B2.1, B6.1, C3.1.1, C3.2, C4, C4.1, C5, C6.1, D1.2, D4.1, D4.2, E2.2
$E_n$	Nominal earthquake load	A5.1.4
$E_o$	Initial column imperfection; a measure of the initial twist of the stud from the initial, ideal, unbuckled location	D4.1
$E_1$	Term used to compute shear strain in wallboard	D4.1
$E'$	Inelastic modulus of elasticity	D4.1
$e_{min}$	Minimum allowable distance measured in the line of force from the centerline of a weld to the nearest edge of an adjacent weld or to the end of the connected part toward which the force is directed	E2.2

Symbol	Definition	Section
$e_{min}$	The distance $e$ measured in the line of force from the centerline of a standard hole to the nearest edge of an adjacent hole or to the end of the connected part toward which the force is directed	E3.1
$e_y$	Yield strain = $F_y/E$	C3.1.1
$F_e$	Elastic buckling stress	C4, C4.1, C4.2, C4.3, C6.2, D4.1
$F_m$	Mean value of the fabrication factor	F1
$F_n$	Nominal buckling stress	C4, C6.2
$F_{nt}$	Nominal tensile strength of bolts	E3.4
$F_{nv}$	Nominal shear strength of bolts	E3.4
$F'_{nt}$	Nominal tensile strength for bolts subject to combination of shear and tension	E3.4
$F_{sy}$	Yield point as specified in Sections A3.1 or A3.2	A3.1, A3.2, A3.3.2, E2.2, E3.1, E3.2
$F_u$	Tensile strength as specified in Sections A3.1 or A3.2, or as reduced for low ductility steel	A3.1, A3.2, A3.3, A3.3.2, E2.2, E2.3, E2.4, E2.5, E3.1, E3.2, E3.3, E4



Symbol	Definition	Section
$F_{uv}$	Tensile strength of virgin steel specified by Section A3 or established in accordance with Section F3.3	A3, A5.5.2, E2.2, F3.3
$F_{wy}$	Yield point for design of transverse stiffeners	B6.1
$F_{xx}$	Strength level designation in AWS electrode classification	E2.2, E2.3, E2.4, E2.5
$F_y$	Yield point used for design, not to exceed the specified yield point or established in accordance with Section F3, or as increased for cold work of forming in Section A5.2.2 or as reduced for low ductility steels in Section A3.3.2	A1.2, A3.3, A5.2.1, A5.2.2, B2.1, B5, B6.1, C2, C3.1, C3.2, C4, C6.1, C6.2, D1.2, D4.2, E2
$F_{ya}$	Average yield point of section	A5.2.1, E5.1
$F_{yc}$	Tensile yield point of corners	A5.2.1
$F_{yf}$	Weighted average tensile yield point of the flat portions	A5.2.1, F3.2
$F_{ys}$	Yield point of stiffener steel	B6.1
$F_{yv}$	Tensile yield point of virgin steel specified by Section A3 or established in accordance with Section F3.3	A3, A5.2.2, F3.3
$f$	Stress in the compression element computed on the basis of the effective design width	B2.1, B2.2, B3.2, B4, B4.1

Symbol	Definition	Section
$f_{av}$	Average computed stress in the full, unreduced flange width	B1.1b
$f'_c$	Specified compression stress of concrete	E5.1
$f_d$	Computed compressive stress in the element being considered. Calculations are based on the effective section at the load for which deflections are determined	B2.1, B2.2, B3.1, B4.1, B4.2
$f_{d1}, f_{d2}$	Computed stresses $f_1$ and $f_2$ as shown in Fig. B2.3-1. Calculations are based on the effective section at the load for which deflections are determined	B2.3
$f_{d3}$	Computed stress $f_3$ in edge stiffener, as shown in Fig. B4-2. Calculations are based on the effective section at the load for which deflections are determined	B3.2
$f_v$	Computed shear stress on a bolt	E4
$f_1, f_2$	Web stresses defined by Fig. B2.3-1	B2.3
$f_3$	Edge stiffener stress defined by Fig. B4.2	B3.2
$G$	Shear modulus for steel	C3.1.1, D4.1
$G'$	Inelastic shear modulus	D4.1
$g$	Vertical distance between two rows of connections nearest to the top and bottom flanges	D1.1

Symbol	Definition	Section
$h$	Depth of flat portion of web measured along the plane of web	B1.2, B6.2, C3.2, C3.4
$I_a$	Adequate moment of inertia of stiffener so that each component element will behave as a stiffened element	B1.1, B4, B4.1, B4.2
$I_b$	Moment of inertia of the full unreduced section about the bending axis	C5
$I_s$	Actual moment of inertia of the full stiffener about its own centroidal axis parallel to the element to be stiffened	B1.1, B4, B4.1, B4.2, B5
$I_{sf}$	Moment of inertia of the full area of the multiple stiffened element, including the intermediate stiffeners, about its own centroidal axis parallel to the element to be stiffened	B5
$I_x, I_y$	Moment of inertia of full section about principal axes	D1.1, D3.2.2
$I_{xy}$	Product of inertia of full section about major and minor centroidal axes	D3.2.2, D4.1
$I_{yc}$	Moment of inertia of the compression portion of a section about the gravity axis of the entire section about the y-axis	C3.1.2
$J$	St. Venant torsion constant	C3.1.2
$j$	Section property for torsional-flexural buckling	C3.1.2

Symbol	Definition	Section
K	Effective length factor	C3.1.2, C4, C4.1, C5
K'	A constant	D3.2.2
$K_b$	Effective length factor in the plane of bending	C5
$K_t$	Effective length factor for torsion	C3.1.2
$K_x$	Effective length factor for bending about x-axis	C3.1.2
$K_y$	Effective length factor for bending about y-axis	C3.1.2
k	Plate buckling coefficient	B2.1, B2.3, B3.1, B3.2, B4, B4.1, B4.2
$k_v$	Shear buckling coefficient	B6.2, C3.2
L	Full span for simple beams, distance between inflection points for continuous beams, twice the length of cantilever beams	B1.1c, D3.2.1
L	Length of seam weld not including the circular ends	E2.3
L	Length of fillet weld	E2.4, E2.5
L	Unbraced length of member	C3.1.2, C4.1, D1.1
$L_n$	Nominal live load	A5.1.4
$L_{rn}$	Nominal roof live load	A5.1.4
$L_{st}$	Length of transverse stiffener	B6.1
$L_t$	Unbraced length of compression member for torsion	C3.1.2
$L_x$	Unbraced length of compression member for bending about x-axis	C3.1.2

Symbol	Definition	Section
$L_y$	Unbraced length of compression member for bending about y-axis	C3.1.2
$M_c$	Critical moment	C3.1.2
$M_e$	Elastic critical moment	C3.1.2
$M_m$	Mean value of the material factor	F1
$M_n$	Nominal flexural strength	C3.1, C3.1.1, C3.1.2, C6.1
$M_{nx}, M_{ny}$	Nominal flexural strengths about the centroidal axes determined in accordance with Section C3	C5
$M_u$	Required flexural strength	C3.3, C3.5
$M_{ux}$	Required flexural strength about x-axis	C5
$M_{uy}$	Required flexural strength about y-axis	C5
$M_y$	Moment causing a maximum strain $e_y$	B2.1, C3.1
$M_1$	Smaller end moment	C3.1.2, C5
$M_2$	Larger end moment	C3.1.2, C5
$m$	Distance from the shear center of one channel to the mid-plane of its web	D3.2.2, D1.1
$N$	Actual length of bearing	D3.6
$n$	Number of holes	E4
$n$	Number of tests	F1
$n_p$	Number of parallel purlin lines	D3.2.1
$P_E$	$\pi^2 EI_b / (K_b L_b)^2$	C5
$P_L$	Force to be resisted by intermediate beam brace	D3.2.1
$P_m$	Mean value of the tested-to-predicted load ratios	F1

Symbol	Definition	Section
$P_n$	Nominal axial strength of member	C4, C6.2
$P_n$	Nominal strength of connection component	E2, E2.2, E2.3, E2.4, E2.5
$P_{no}$	Nominal axial strength of member determined in accordance with Section C4 for $L = 0$	C5
$P_u$	Required axial strength	C5
$\bar{Q}$	Design shear rigidity for sheathing on both sides of the wall assembly	D4.1
$Q_i$	Load effect	F1
$q$	Uniformly distributed factored load in the plane of the web	D1.1
$\bar{q}$	Design shear rigidity for sheathing per inch of stud spacing	D4.1
$\bar{q}_o$	Factor used to determine design shear rigidity	D4.1
$R$	Reduction factor	C3.1.3
$R$	Coefficient	C4, C6.2
$R$	Inside bend radius	A5.2.1, C3.4
$R_{rn}$	Nominal roof rain load	A5.1.4
$R_n$	Nominal resistance	F1
$R_p$	Average value of all test results	F1
$r$	Radius of gyration of full, unreduced cross section	C3.1.1, C4, C4.1

Symbol	Definition	Section
$r$	Force transmitted by the bolt or bolts at the section considered, divided by the tension force in the member at that section	E3.2
$r_{cy}$	Radius of gyration of one channel about its centroidal axis parallel to web	D1.1
$r_I$	Radius of gyration of I-section about the axis perpendicular to the direction in which buckling would occur for the given conditions of end support and intermediate bracing	D1.1
$r_o$	Polar radius of gyration of cross section about the shear center	C3.1.1, C4.2, D4.1
$r_x, r_y$	Radius of gyration of cross section about centroidal principal axes	C3.1.1
$S$	$1.28\sqrt{E/f}$	B4, B4.1
$S_c$	Elastic section modulus of the effective section calculated at a stress $M_c/S_f$ in the extreme fiber	C3.1.1, C3.1.2, C4
$S_e$	Elastic section modulus of the effective section calculated with extreme compression or tension fiber at $F_y$	C3.1.1
$S_f$	Elastic section modulus of full, unreduced section for the extreme compression fiber	C3.1.1, C3.1.2, C6.1
$S_n$	Nominal snow load	A5.1.4

Symbol	Definition	Section
$s_{max}$	Maximum permissible longitudinal spacing of welds or other connectors joining two channels to form an I-section	D1.1
$s$	Fastener spacing	D1.2, D4.1
$s$	Spacing in line of stress of welds, rivets, or bolts connecting a compression coverplate or sheet to a non-integral stiffener or other element	E3.2
$s$	Weld spacing	D1.1
$T_n$	Nominal tensile strength	C2
$T_s$	Design strength of connection in tension	D1.1
$t$	Base steel thickness of any element or section	A1.2, A3.4, A5.2.1, B1.1, B1.1b, B1.2, B2.1, B4, B4.1, B4.2, B5, B6.1, C3.1.1, C3.2, C3.4, C4, C6.1, C6.2, D1.2, E2.4, E2.5
$t$	Thickness of the thinnest connected part	E3.1, E4
$t_s$	Equivalent thickness of a multiple-stiffened element	B5, B6.1
$t_w$	Effective throat of weld	E2.4, E2.5



Symbol	Definition	Section
$V_F$	Coefficient of variation of the fabrication factor	F1
$V_M$	Coefficient of variation of the material factor	F1
$V_n$	Nominal shear strength	B6.2, C3.2, C3.3
$V_P$	Coefficient of variation of the tested-to-predicted load ratios	F1
$V_Q$	Coefficient of variation of the load effect	F1
$V_u$	Required shear strength	C3.3
$W$	Factored load supported by all purlin lines being restrained	D3.2.1
$W_n$	Nominal wind load	A5.1.4
$w$	Flat width of element exclusive of radii	A1.2, B1.1, B2.1, B2.2, B3.1, B4, B4.1, B4.2, B5, C3.1.1, C4, D1.2
$w_f$	Width of flange projection beyond the web or half the distance between webs for box- or U-type sections	B1.1c
$w_f$	Projection of flanges from inside face of web	B1.1b, D1.1
$w_1$	Leg on weld	E2.4
$w_2$	Leg on weld	E2.4

Symbol	Definition	Section
$x$	Distance from concentrated load to brace	D3.2
$x_o$	Distance from shear center to centroid along the principal x-axis	C3.1.1, C4.2, D4.1
$Y$	Yield point of web steel divided by yield point of stiffener steel	B6.2
$1/\alpha_{nx}$ , $1/\alpha_{ny}$	Magnification factors	C5
$\beta$	Coefficient	C4.2, D4.1
$\beta_o$	Target reliability index	F1
$\gamma$	Actual shear strain in the sheathing	D4.1
$\bar{\gamma}$	Permissible shear strain of the sheathing	D4.1
$\gamma_i$	Load factor	F1
$\theta$	Angle between web and bearing surface $> 45^\circ$ but no more than $90^\circ$	C3.4
$\theta$	Angle between the vertical and the plane of the web of the Z-section, degrees	D3.2.1
$\sigma$	Stress related to shear strain in sheathing	D4.1
$\sigma_{CR}$	Theoretical elastic buckling stress	D4.1
$\sigma_t$	Torsional buckling stress	C3.1.1, C4.2, D4.1
$\rho$	Reduction factor	B2.1
$\lambda, \lambda_c$	Slenderness factors	B2.1, C3.5.2
$\psi$	$f_2/f_1$	B2.3

Symbol	Definition	Section
$\phi$	Resistance factor	A5.1.5, E2, E2.1, E2.2, E2.3, E2.4, E2.5, E2.6, E3.1, E3.2, E3.3, E3.4, E4, F1
$\phi_b$	Resistance factor for bending strength	A5.1.5, C3, C3.1.1, C3.1.2, C3.1.3, C3.3, C3.5, C5, C6.1, C6.3, D4.2, D4.3
$\phi_c$	Resistance factor for concentrically loaded compression member	A3.3.1, A5.1.5, B6.1, C4, C5, C6.2, C6.3, D4.1, D4.3
$\phi_c$	Resistance factor for bearing strength	E5.1
$\phi_t$	Resistance factor for tension member	C2
$\phi_v$	Resistance factor for shear strength	B6.2, C3.2, C3.3
$\phi_w$	Resistance factor for web crippling strength	C3.4, C3.5

LOAD AND RESISTANCE FACTOR DESIGN SPECIFICATION FOR  
COLD-FORMED STEEL STRUCTURAL MEMBERS

A. GENERAL PROVISIONS

A1 Limits of Applicability and Terms

A1.1 Scope and Limits of Applicability

This Load and Resistance Factor Design Specification is intended as an alternate to the Specification for the Design of Cold-Formed Steel Structural Members of the American Iron and Steel Institute.

This specification shall apply to the design of structural members cold-formed to shape from carbon or low-alloy steel sheet, strip, plate or bar not more than one inch in thickness and used for load-carrying purposes in buildings. It may also be used for structures other than buildings provided appropriate allowances are made for thermal and/or dynamic effects.

A1.2 Terms

Where the following terms appear in this Specification they shall have the meaning herein indicated:

(a) Stiffened or Partially Stiffened Compression Elements. A stiffened or partially stiffened compression element is a flat compression element (i.e., a plane compression flange of a flexural member or a plane web or flange of a compression member) of which both edges parallel to the direction of stress are stiffened by a web, flange, stiffening lip, intermediate stiffener, or the like.

(b) Unstiffened Compression Elements. An unstiffened compression element is a flat compression element which is stiffened at only one edge parallel to the direction of stress.

(c) Multiple-Stiffened Elements. A multiple-stiffened element is an element that is stiffened between webs, or between a web and a stiffened edge, by means of intermediate stiffeners which are parallel to the direction of stress. A sub-element is the portion between adjacent stiffeners or between web and intermediate stiffener or between edge and intermediate stiffener.

(d) Flat-Width-to-Thickness Ratio. The flat width of an element measured along its plane, divided by its thickness.

(e) Effective Design Width. Where the flat width of an element is reduced for design purposes, the reduced design width is termed the effective width or effective design width.

(f) Thickness. The thickness,  $t$ , of any element or section shall be the base steel thickness, exclusive of coatings.

(g) Torsional-Flexural Buckling. Torsional-flexural buckling is a mode of buckling in which compression members can bend and twist simultaneously.

(h) Point-Symmetric Section. A point-symmetric section is a section symmetrical about a point (centroid) such as a Z-section having equal flanges.

(i) Yield Point. Yield point,  $F_y$  or  $F_{sy}$ , as used in this Specification shall mean yield point or yield strength.

(j) Stress. Stress as used in this Specification means force per unit area.

(k) Confirmatory Test. A confirmatory test is a test made, when desired, on members, connections, and assemblies designed according to the provisions of Sections A through E of this Specification or its specific references, in order to compare actual versus calculated performance.

(l) Performance Test. A performance test is a test made on structural members, connections, and assemblies whose performance cannot be determined by the provisions of Sections A through E of this Specification or its specific references.

(m) Virgin Steel. Virgin steel refers to steel as received from the steel producer or warehouse before being cold worked as a result of fabricating operations.

(n) Virgin Steel Properties. Virgin steel properties refer to mechanical properties of virgin steel such as yield point, tensile strength, and elongation.

(o) Specified Minimum Yield Point. The specified minimum yield point is the lower limit of yield point which must be equalled or exceeded in a specification test to qualify a lot of steel for use in a cold-formed steel structural member designed at that yield point.

(p) Cold-Formed Steel Structural Members. Cold-formed steel structural members are shapes which are manufactured by press-braking blanks sheared from sheets, cut lengths of coils or plates, or by roll forming cold- or hot-rolled coils or sheets; both forming operations being performed at ambient room temperature, that is, without manifest addition of heat such as would be required for hot forming.

(q) LRFD (Load and Resistance Factor Design). A method of proportioning structural components (members, connectors, connecting elements and

assemblages) such that no applicable limit state is exceeded when the structure is subjected to all appropriate load combinations.

(r) Design Strength. Factored resistance or strength (force, moment, as appropriate),  $\phi R_n$ , provided by the structural component.

(s) Required Strength. Load effect (force, moment, as appropriate) acting on the structural component determined by structural analysis from the factored loads (using most appropriate critical load combinations).

### A1.3 Units of Symbols and Terms

The Specification is written so that any compatible system of units may be used except where explicitly stated otherwise in the text of these provisions.

### A2 Non-Conforming Shapes and Construction

The provisions of the Specification are not intended to prevent the use of alternate shapes or constructions not specifically prescribed herein. Such alternates shall meet the provisions of Section F of the Specification and be approved by the appropriate building code authority.

### A3 Material

#### A3.1 Applicable Steels

This Specification requires the use of steel of structural quality as defined in general by the provisions of the following specifications of the American Society for Testing and Materials:

ASTM A36/A36M-84a, Structural Steel

ASTM A242/A242M-85, High-Strength Low-Alloy Structural Steel

ASTM A441M-85, High-Strength Low-Alloy Structural Manganese Vanadium Steel

ASTM A446/A446M-85 (Grades A, B, C, D, & F) Steel, Sheet, Zinc-Coated (Galvanized) by the Hot-Dip Process, Structural (Physical) Quality

ASTM A500-84, Cold-Formed Welded and Seamless Carbon Steel Structural Tubing in Rounds and Shapes

ASTM A529/A529M-85, Structural Steel with 42 ksi Minimum Yield Point (1/2 in. Maximum Thickness)

ASTM A570/A570M-85 Steel, Sheet and Strip, Carbon, Hot-Rolled, Structural Quality

ASTM A572/A572M-85, High-Strength Low-Alloy Columbium-Vanadium Steels of Structural Quality

ASTM A588/A588M-85, High-Strength Low-Alloy Structural Steel with 50 ksi Minimum Yield Point to 4 in. Thick

ASTM A606-85 Steel, Sheet and Strip, High Strength, Low Alloy, Hot-Rolled and Cold-Rolled, with Improved Atmospheric Corrosion Resistance

ASTM A607-85 Steel Sheet and Strip, High Strength, Low Alloy, Columbium or Vanadium, or both, Hot-Rolled and Cold-Rolled

ASTM A611-85 (Grades A, B, C, & D) Steel, Sheet, Carbon, Cold-Rolled, Structural Quality

ASTM A715-85 (Grades 50 and 60) Sheet Steel and Strip, High-Strength, Low-Alloy, Hot-Rolled, with Improved Formability

ASTM A792-85a (Grades 33, 37, 40 & 50) Steel Sheet, Aluminum-Zinc Alloy-Coated by the Hot-Dip Process, General Requirements

### A3.2 Other Steels



The listing in Section A3.1 does not exclude the use of steel up to and including one inch in thickness ordered or produced to other than the listed specifications provided such steel conforms to the chemical and mechanical requirements of one of the listed specifications or other published specification which establishes its properties and suitability, and provided it is subjected by either the producer or the purchaser to analyses, tests and other controls to the extent and in the manner prescribed by one of the listed specifications and Section A3.3.

### A3.3 Ductility

Steels not listed in Section A3.1 and used for structural members and connections shall comply with one of the following ductility requirements:

A3.3.1 The ratio of tensile strength to yield point shall not be less than 1.08, and the total elongation shall not be less than 10 percent for a two-inch gage length or 7 percent for an eight-inch gage length standard specimen tested in accordance with ASTM A370-77. If these requirements cannot be met, the following criteria shall be satisfied: (1) local elongation in a 1/2 inch gage length across the fracture shall not be less than 20%, (2) uniform elongation outside the fracture shall not be less than 3%\*. When material ductility is determined on the basis of the local and

---

\*Further information on the test procedures should be obtained from the Commentary.

uniform elongation criteria, the use of such material is restricted to the design of purlins and girts<sup>\*\*</sup> in accordance with Sections C3.1.1(a), C3.1.2, and C3.1.3. For purlins and girts subject to combined axial load and bending moment (Section C5),  $P_u/\phi_c P_n$  shall not exceed 0.15.

A3.3.2 Steels conforming to ASTM A446 Grade E and A611 Grade E and other steels which do not meet the provisions of Section A3.3.1 may be used for particular configurations provided (1) the yield strength,  $F_y$ , used for design in Chapters B, C and D is taken as 75 percent of the specified minimum yield point or 60 ksi, whichever is less and (2) the tensile strength,  $F_u$ , used for design in Chapter E is taken as 75 percent of the specified minimum tensile stress or 62 ksi, whichever is less. Alternatively, the suitability of such steels for the configuration shall be demonstrated by load tests in accordance with Section F1. Design strengths based on these tests shall not exceed the strengths calculated according to Chapters B through E, using the specified minimum yield point,  $F_{sy}$ , for  $F_y$  and the specified minimum tensile strength,  $F_u$ .

Design strengths based on existing use shall not exceed the strengths calculated according to Chapters B through E, using the specified minimum yield point,  $F_{sy}$ , for  $F_y$  and the specified minimum tensile strength,  $F_u$ .

---

<sup>\*\*</sup>Horizontal structural members which support roof deck or panel covering and applied loads principally by bending.

#### A3.4 Delivered Minimum Thickness

The uncoated minimum steel thickness of the cold-formed product as delivered to the job site shall not at any location be less than 95 percent of the thickness,  $t$ , used in its design; however, thicknesses may be less at bends, such as corners, due to cold-forming effects.

#### A4 Loads

##### A4.1 Dead Load

The dead load to be assumed in design shall consist of the weight of steelwork and all material permanently fastened thereto or supported thereby.

##### A4.2 Live or Snow Load

The live or snow load shall be that stipulated by the applicable code or specification under which the structure is being designed or that dictated by the conditions involved.

##### A4.3 Impact Load

For structures carrying live loads which induce impact, the assumed live load shall be increased sufficiently to provide for impact.

##### A4.4 Wind or Earthquake Load

Wind or earthquake load shall be that stipulated by the applicable code or specification under which the structure is being designed or that dictated by the conditions involved.

#### A4.5 Ponding

Unless a roof surface is provided with sufficient slope toward points of free drainage or adequate individual drains to prevent the accumulation of rainwater, the roof system shall be investigated by rational analysis to assure stability under ponding conditions.

### A5 Structural Analysis and Design

#### A5.1 Design Basis

This Specification is based on the Load and Resistance Factor Design concept. Load and Resistance Factor Design is a method of proportioning cold-formed steel structural components (i.e., members, connectors and connections) such that any applicable limit state is not exceeded when the structure is subjected to any appropriate load combinations.

Two types of limit states are to be considered: 1) the limit state of the strength required to resist the extreme loads during the intended life of the structure, and 2) the limit state of the ability of the structure to perform its intended function during its life. These limit states will be called the Limit State of Strength and the Limit State of Serviceability, respectively, in these criteria.

##### A5.1.1 Limit State - Strength

The design is satisfactory when the required strengths, as determined from the assigned nominal loads which are multiplied by appropriate load factors, are smaller than or equal to the design strength of each structural component.

The design strength is equal to  $\phi R_n$ , where  $\phi$  is a resistance factor and  $R_n$  is the nominal strength determined according to the formulas given in Chapter C for members, in Chapter D for structural assemblies and in Chapter E for connections. Values of resistance factors  $\phi$  are given in Section A5.1.5 for the appropriate limit states governing member and connection strength.

#### A5.1.2 Limit State - Serviceability

Serviceability is satisfactory if a nominal structural response (e.g. live load deflection) due to the applicable nominal loads is less than or equal to the appropriate acceptable or allowable value of this response.

#### A5.1.3 Nominal Loads

The nominal loads shall be the minimum design loads stipulated by the applicable code under which the structure is designed or dictated by the conditions involved. In the absence of a code, the loads and load combinations shall be those stipulated in the American National Standard, Minimum Design Loads for Buildings and Other Structures, ANSI A58.1. For design purposes, the loads stipulated by the applicable code shall be taken as nominal loads.

#### A5.1.4 Load Factors and Load Combinations<sup>\*</sup>

The structure and its components must be designed for the appropriate most critical load combination. The following load combinations of the factored nominal loads shall be used in the computation of the required strengths:

1.  $1.4 D_n + L_n$
2.  $1.2 D_n + 1.6 L_n + 0.5(L_{rn} \text{ or } S_n \text{ or } R_{rn})$
3.  $1.2 D_n + (1.4 L_{rn} \text{ or } 1.6 S_n \text{ or } 1.6 R_{rn}) + (0.5 L_n \text{ or } 0.8 W_n)$
4.  $1.2 D_n + 1.3 W_n + 0.5 L_n + 0.5(L_{rn} \text{ or } S_n \text{ or } R_{rn})$
5.  $1.2 D_n + 1.5 E_n + (0.5 L_n \text{ or } 0.2 S_n)$
6.  $0.9 D_n - (1.3 W_n \text{ or } 1.5 E_n)$

where  $D_n$  = nominal dead load

$E_n$  = nominal earthquake load

$L_n$  = nominal live load

$L_{rn}$  = nominal roof live load

$R_{rn}$  = nominal roof rain load

$S_n$  = nominal snow load

$W_n$  = nominal wind load (Exception: For wind load on individual purlins, girts, wall panels and roof decks, multiply the load factor for  $W_n$  by 0.9)

---

\* For roof and floor construction, recommended load combinations for dead load, weight of wet concrete, and construction load including equipment, workmen and formwork are given in Section A5.1 of the Commentary.

Exception: The load factor for  $L_n$  in combinations (3), (4), and (5) shall equal to 1.0 for garages, areas occupied as places of public assembly, and all areas where the live load is greater than 100 psf.

When the structural effects of F, H, P or T are significant, they shall be considered in design as the following factored loads: 1.3F, 1.6H, 1.2P, and 1.2T, where

F = loads due to fluids with well-defined pressures and maximum heights

H = loads due to the weight and lateral pressure of soil and water in soil

P = loads, forces, and effects due to ponding

T = self-straining forces and effects arising from contraction or expansion resulting from temperature changes, shrinkage, moisture changes, creep in component materials, movement due to differential settlement, or combinations thereof.

#### A5.1.5 Resistance Factors

The resistance factors to be used for determining the design strengths,  $\phi R_n$ , of structural members and connections shall be taken as follows:

<u>Type of Strength</u>	<u>Resistance Factor, <math>\phi</math></u>
(a) Stiffeners	
Transverse stiffeners-----	0.85
Shear stiffeners*-----	0.90
(b) Tension members-----	0.95
(c) Flexural members	
Bending strength	
For sections with stiffened or partially stiffened	
compression flanges-----	0.95
For sections with unstiffened compression flanges-----	0.90
Laterally unbraced beams-----	0.90
Beams having one flange through-fastened to deck or	
sheathing (C- or Z-sections)-----	0.90
Web design	
Shear strength*-----	0.90
Web crippling	
For single unreinforced webs-----	0.75
For I-sections-----	0.80
(d) Concentrically loaded compression members-----	0.85
(e) Combined axial load and bending	
$\phi_c$ for compression-----	0.85
$\phi_b$ for bending	
Using Section C3.1.1-----	0.90-0.95
Using Section C3.1.2-----	0.90

---

\*When  $h/t \leq \sqrt{Ek_v/F_y}$ ,  $\phi = 1.0$



(f) Cylindrical tubular members	
Bending strength-----	0.95
Axial compression-----	0.85
(g) Wall studs and wall stud assemblies	
Wall studs in compression-----	0.85
Wall studs in bending	
For sections with stiffened or partially stiffened	
compression flanges-----	0.95
For sections with unstiffened compression flanges-----	0.90
(h) Welded connections	
Groove welds	
Tension or compression-----	0.90
Shear (welds)-----	0.80
Shear (base metal)-----	0.90
Arc spot welds	
Welds-----	0.60
Connected part-----	0.50-0.60
Minimum edge distance-----	0.60-0.70
Arc seam welds	
Welds-----	0.60
Connected part-----	0.60
Fillet welds	
Longitudinal loading (connected part)-----	0.55-0.60
Transverse loading (connected part)-----	0.60
Welds-----	0.60
Flare groove welds	
Transverse loading (connected part)-----	0.55

Longitudinal loading (connected part)-----	0.55
Welds-----	0.60
Resistance welds-----	0.65
(i) Bolted connections	
Minimum spacing and edge distance-----	0.60-0.70
Tension strength on net section	
With washers	
Double shear connection-----	0.65
Single shear connection-----	0.55
Without washers-----	0.65
Bearing strength	
See Tables E3.3-1 and E3.3-2-----	0.55-0.70
Shear strength of bolts-----	0.65
Tensile strength of bolts-----	0.75
(j) Shear rupture-----	0.75
(k) Connections to other materials (Bearing)-----	0.60

## A5.2 Yield Point and Strength Increase from Cold Work of Forming

### A5.2.1 Yield Point

The yield point used in design,  $F_y$ , shall not exceed the specified minimum yield point, or as established in accordance with Chapter F, or as increased for cold work of forming in Section A5.2.2 or as reduced for low ductility steels in Section A3.3.2.

### A5.2.2 Strength Increase from Cold Work of Forming

Strength increase from cold work of forming may be obtained by substituting  $F_{ya}$  for  $F_y$ , where  $F_{ya}$  is the average yield point of the full section. Such increase shall be limited to Section C3.1 (excluding Section C3.1.1(b)) C4, C5, C6 and D4. The limitations and methods for determining  $F_{ya}$  are as follows:

(a) For axially loaded compression members and flexural members whose proportions are such that the quantity  $\rho$  is unity as determined according to Section B2 for each of the component elements of the section, the design yield stress,  $F_{ya}$ , of the steel shall be determined on the basis of one of the following methods:

- (1) full section tensile tests (see paragraph (a) of Section F3.1)
- (2) stub column tests (see paragraph (b) of Section F3.1)
- (3) computed as follows:

$$F_{ya} = CF_{yc} + (1-C)F_{yf} \quad (\text{Eq. A5.2.2-1})$$

where

$F_{ya}$  = Average yield point of the steel in the full section of compression members or full flange sections of flexural members

C = For compression members, ratio of the total corner cross-sectional area to the total cross-sectional area of the full section; for flexural members, ratio of the total corner cross-sectional area of the controlling flange to the full cross-sectional area of the controlling flange

$F_{yf}$  = Weighted average tensile yield point of the flat portions established in accordance with Section F3.2

or virgin yield point if tests are not made

$F_{yc} = B_c F_{yv} / (R/t)^m$ , tensile yield point of corners. This formula is applicable only when  $F_{uv}/F_{yv} \geq 1.2$ ,  $R/t \leq 7$ , and minimum included angle  $\leq 120^\circ$  (Eq. A5.2.2-2)

$B_c = 3.69(F_{uv}/F_{yv}) - 0.819(F_{uv}/F_{yv})^2 - 1.79$  (Eq. A5.2.2-3)

$m = 0.192(F_{uv}/F_{yv}) - 0.068$  (Eq. A5.2.2-4)

$R$  = Inside bend radius

$F_{yv}$  = Tensile yield point of virgin steel\* specified by Section A3 or established in accordance with Section F3.3

$F_{uv}$  = Tensile strength of virgin steel\* specified by Section A3 or established in accordance with Section F3.3

- (b) For axially loaded tension members the yield point of the steel shall be determined by either method (1) or method (3) prescribed in paragraph (a) of this Section.
- (c) The effect of any welding on mechanical properties of a member shall be determined on the basis of tests of full section specimens containing within the gage length, such welding as the manufacturer intends to use. Any necessary allowance for such effect shall be made in the structural use of the member.

---

\*Virgin steel refers to the condition (i.e. coiled or straight) of the steel prior to the cold-forming operation.

### A5.3 Durability

A structure shall be designed to perform its required functions during its expected life for durability consideration.

### A6 Reference Documents

This Specification recognizes other published and latest approved specifications and manuals, when applicable, for use in designs contemplated herein, as follows:

1. American National Standards Institute, ANSI A58.1-1982, "Minimum Design Loads in Buildings and Other Structures," American National Standards Institute, Inc., (ANSI), 1430 Broadway, New York, New York 10018
2. Applicable standards of the American Society for Testing and Materials, (ASTM), 1916 Race Street, Philadelphia, Pennsylvania 19013
3. American Institute of Steel Construction, "Allowable Stress Design Specification for Structural Steel Buildings with a Chapter on Plastic Design," American Institute of Steel Construction, (AISC), 400 North Michigan Avenue, Chicago, Illinois 60611, June 1, 1989
4. American Welding Society, AWS D1.3-81, "Structural Welding Code-Sheet Steel," American Welding Society, (AWS), 550 N. W. LeJeune Road, Miami, Florida 33126
5. Research Council on Structural Connections, "Allowable Stress Design Specification for Structural Joints Using ASTM A325 or A490 Bolts,"

Research Council on Structural Connections, (RCSC), American Institute of Steel Construction (AISC), 400 North Michigan Avenue, Chicago, Illinois 60611, November 13, 1985

6. Metal Building Manufacturers Association, "Low Rise Building Systems Manual," Metal Building Manufacturers Association (MBMA), 1230 Keith Building, Cleveland, Ohio 44115
7. Steel Deck Institute, "Design Manual for Composite Decks, Formed Decks, and Roof Decks," Steel Deck Institute, Inc., P. O. Box 9506, Canton, Ohio 44711, 1984
8. Steel Joist Institute, "Standard Specifications Load Tables and Weight Tables for Steel Joists and Joist Girders," Steel Joist Institute, (SJI), Suite A, 1205 48th Avenue North, Myrtle Beach, South Carolina 29577, 1986
9. Rack Manufacturers Institute, "Specification for the Design, Testing and Utilization of Industrial Steel Storage Racks," Rack Manufacturers Institute, (RMI), 8720 Red Oak Boulevard, Suite 201, Charlotte, North Carolina 28210, 1985
10. American Iron and Steel Institute, "Stainless Steel Cold-Formed Structural Design Manual," 1974 Edition, American Iron and Steel Institute, (AISI), 1133 15th Street, N. W., Washington, D. C. 20005
11. American Society of Civil Engineers, "ASCE Standard, Specification for the Design and Construction of Composite Slabs," American Society

of Civil Engineers, (ASCE), 345 East 47th Street, New York, New York  
10017, October, 1984

12. American Iron and Steel Institute, "Tentative Criteria for Structural  
Applications of Steel Tubing and Pipe," American Iron and Steel In-  
stitute, (AISI), 1133 15th Street, N. W., Washington, D. C. 20005,  
August 1976

13. American Institute of Steel Construction, "Load and Resistance Factor  
Design Specification for Structural Steel Buildings", American In-  
stitute of Steel Construction, (AISC), 400 North Michigan Avenue,  
Chicago, Illinois 60611, September 1, 1986

## B. ELEMENTS

### B1 Dimensional Limits and Considerations

#### B1.1 Flange Flat-Width-to-Thickness Considerations

##### (a) Maximum Flat-Width-to-Thickness Ratios

Maximum allowable overall flat-width-to-thickness ratios,  $w/t$ , disregarding intermediate stiffeners and taking as  $t$  the actual thickness of the element, shall be as follows:

- (1) Stiffened compression element having one longitudinal edge connected to a web or flange element, the other stiffened by:

Simple lip	60
Any other kind of stiffener having $I_s > I_a$ and $D/w < 0.8$ according to Section B4.2	90
- (2) Stiffened compression element with both longitudinal edges connected to other stiffened elements 500
- (3) Unstiffened compression element and elements with an edge stiffener having  $I_s < I_a$  and  $D/w \leq 0.8$  according to Section B4.2 60

Note: Unstiffened compression elements that have  $w/t$  ratios exceeding approximately 30 and stiffened compression elements that have  $w/t$  ratios exceeding approximately 250 are likely to develop



noticeable deformation at the full design strength, without affecting the ability of the member to carry required strength. Stiffened elements having w/t ratios larger than 500 can be used with adequate design strength to sustain the required loads, however, substantial deformations of such elements usually will invalidate the design formulas of this Specification.

(b) Flange Curling

Where the flange of a flexural member is unusually wide and it is desired to limit the maximum amount of curling or movement of the flange toward the neutral axis, the following formula applies to the compression and tension flanges, either stiffened or unstiffened:

$$w_f = \sqrt{0.061tdE/f_{av}} \sqrt[4]{(100c_f/d)} \quad (\text{Eq. B1.1b-1})$$

where

$w_f$  = Width of flange projecting beyond the web; or half of the distance between webs for the box- or U-type beams

$t$  = Flange thickness

$d$  = Depth of beam

$c_f$  = Amount of curling<sup>\*</sup>

$f_{av}$  = Average stress in the full, unreduced flange width. (Where members are designed by the effective design width procedure, the average stress equals the maximum stress multiplied by the ratio of the effective design width to the actual width.)

---

\*The amount of curling that can be tolerated will vary with different kinds of sections and must be established by the designer. Amount of curling in the order of 5 percent of the depth of the section is usually not considered excessive.

(c) Shear Lag Effects - Unusually Short Spans Supporting Concentrated Loads  
 Where the span of the beam is less than  $30w_f$  ( $w_f$  as defined below) and it carries one concentrated load, or several loads spaced farther apart than  $2w_f$ , the effective design width of any flange, whether in tension or compression, shall be limited to the following:

TABLE B1.1(c)

SHORT, WIDE FLANGES

MAXIMUM ALLOWABLE RATIO OF EFFECTIVE DESIGN WIDTH TO ACTUAL WIDTH

$L/w_f$	Ratio	$L/w_f$	Ratio
30	1.00	14	0.82
25	0.96	12	0.78
20	0.91	10	0.73
18	0.89	8	0.67
16	0.86	6	0.55

where

$L$  = Full span for simple beams; or the distance between inflection points for continuous beams; or twice the length of cantilever beams.

$w_f$  = Width of flange projection beyond the web for I-beam and similar sections or half the distance between webs of box- or U-type sections.

For flanges of I-beams and similar sections stiffened by lips at the outer edges,  $w_f$  shall be taken as the sum of the flange projection beyond the web plus the depth of the lip.

#### B1.2 Maximum Web Depth-to-Thickness Ratio

The ratio,  $h/t$ , of the webs of flexural members shall not exceed the following limitations:

- (a) For unreinforced webs:  $(h/t)_{\max} = 200$
- (b) For webs which are provided with transverse stiffeners satisfying the requirements of Section B6.1:
  - (1) When using bearing stiffeners only,  $(h/t)_{\max} = 260$
  - (2) When using bearing stiffeners and intermediate stiffeners,  
 $(h/t)_{\max} = 300$

In the above,

$h$  = Depth of flat portion of web measured along the plane of web

$t$  = Web thickness

Where a web consists of two or more sheets, the  $h/t$  ratio shall be computed for the individual sheets.

#### B2 Effective Widths of Stiffened Elements

##### B2.1 Uniformly Compressed Stiffened Elements

###### (a) Load Capacity Determination

The effective widths,  $b$ , of uniformly compressed elements shall be determined from the following formulas:

$$b = w \text{ when } \lambda \leq 0.673 \quad (\text{Eq. B2.1-1})$$

$$b = \rho w \text{ when } \lambda > 0.673 \quad (\text{Eq. B2.1-2})$$

where

$w$  = Flat width as shown in Figure B2.1-1

$$\rho = (1 - 0.22/\lambda) / \lambda \quad (\text{Eq. B2.1-3})$$

$\lambda$  is a slenderness factor determined as follows:

$$\lambda = (1.052/\sqrt{k})(w/t)(\sqrt{f/E}) \quad (\text{Eq. B2.1-4})$$

$t$  = Thickness of the uniformly compressed stiffened elements

where

$f$  for load capacity determination is as follows:

For flexural members:

- (1) If Procedure I of Section C3.1.1 is used,  $f = F_y$  if the initial yielding is in compression in the element considered.

If the initial yielding is not in compression in the element considered, then the stress  $f$  shall be determined for the element considered on the basis of the effective section at  $M_y$  (moment causing initial yield).

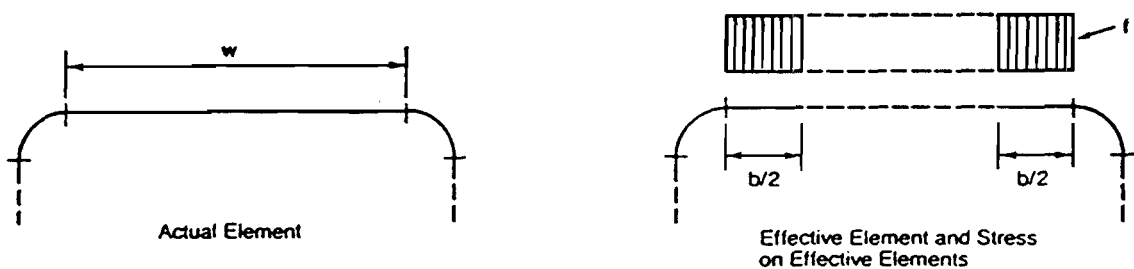

Figure B2.1-1 Stiffened Elements with Uniform Compression

- (2) If procedure II of Section C3.1.1 is used, then  $f$  is the stress in the element considered at  $M_n$  determined on the basis of the effective section.
- (3) If Section C3.1.2 is used, then the  $f = M_c / S_f$  as described in that Section in determining  $S_c$ .

For compression members  $f$  is taken equal to  $F_n$  as determined in Section C4 or D4.1 as applicable.

$E$  = Modulus of elasticity

$k$  = Plate buckling coefficient

= 4 for stiffened elements supported by a web on each longitudinal edge. Values for different types of elements are given in the applicable sections.

(b) Deflection Determination

The effective widths,  $b_d$ , used in computing deflection shall be determined from the following formulas:

$$b_d = w \text{ when } \lambda \leq 0.673 \quad (\text{Eq. B2.1-5})$$

$$b_d = \rho w \text{ when } \lambda > 0.673 \quad (\text{Eq. B2.1-6})$$

where

$w$  = Flat width

$\rho$  = Reduction factor determined by either of the following two procedures:

(1) Procedure I.

A low estimate of the effective width may be obtained from Eqs. B2.1-3 and B2.1-4 where  $f_d$  is substituted for  $f$  where  $f_d$  is the computed compressive stress in the element being considered.

(2) Procedure II.

For stiffened elements supported by a web on each longitudinal edge an improved estimate of the effective width can be obtained by calculating  $\rho$  as follows:

$$\rho = 1 \text{ when } \lambda \leq 0.673 \quad (\text{Eq. B2.1-7})$$

$$\rho = (1.358 - 0.461/\lambda)/\lambda \text{ when } 0.673 < \lambda < \lambda_c \quad (\text{Eq. B2.1-8})$$

$$\rho = (0.41 + 0.59\sqrt{F_y/f_d} - 0.22/\lambda)/\lambda \text{ when } \lambda \geq \lambda_c \quad (\text{Eq. B2.1-9})$$

where

$$\lambda_c = 0.256 + 0.328(w/t)\sqrt{F_y/E} \quad (\text{Eq. B2.1-10})$$

and  $\lambda$  is as defined by Eq. B2.1-4 except that  $f_d$  is substituted for  $f$ .

## B2.2 Uniformly Compressed Stiffened Elements with Circular Holes

### (a) Load Capacity Determination

The effective width,  $b$ , of stiffened elements with uniform compression having circular holes shall be determined as follows:

for  $0.50 \geq d_h/w \geq 0$ , and  $w/t \leq 70$

center-to-center spacing of holes  $> 0.50w$  and  $3d_h$ ,

$$b = w - d_h \text{ when } \lambda \leq 0.673 \quad (\text{Eq. B2.2-1})$$

$$b = w(1 - 0.22/\lambda - 0.8d_h/w)/\lambda \text{ when } \lambda > 0.673 \quad (\text{Eq. B2.2-2})$$

where

$w$  = Flat width

$d_h$  = Diameter of holes

$\lambda$  is as defined in Section B2.1

### (b) Deflection Determination

The effective width,  $b_d$ , used in deflection calculations shall be equal to  $b$  determined in accordance with Procedure I of Section B2.2a except that  $f_d$  is substituted for  $f$ , where  $f_d$  is the

computed compressive stress in the element being considered.

### B2.3 Effective Widths of Webs and Stiffened Elements with Stress Gradient

#### (a) Load Capacity Determination

The effective widths,  $b_1$  and  $b_2$ , as shown in Figure B2.3-1 shall be determined from the following formulas:

$$b_1 = b_e / (3 - \Psi) \quad (\text{Eq. B2.3-1})$$

For  $\Psi \leq -0.236$

$$b_2 = b_e / 2 \quad (\text{Eq. B2.3-2})$$

$b_1 + b_2$  shall not exceed the compression portion of the web calculated on the basis of effective section

For  $\Psi > -0.236$

$$b_2 = b_e - b_1 \quad (\text{Eq. B2.3-3})$$

where

$b_e$  = Effective width  $b$  determined in accordance with Section B2.1 with  $f_1$  substituted for  $f$  and with  $k$  determined as follows:

$$k = 4 + 2(1 - \Psi)^3 + 2(1 - \Psi) \quad (\text{Eq. B2.3-4})$$

$$\Psi = f_2 / f_1$$

$f_1, f_2$  = Stresses shown in Figure B2.3-1 calculated on the basis of effective section.

$f_1$  is compression (+) and  $f_2$  can be either tension (-) or compression. In case  $f_1$  and  $f_2$  are both compression,  $f_1 \geq f_2$ .

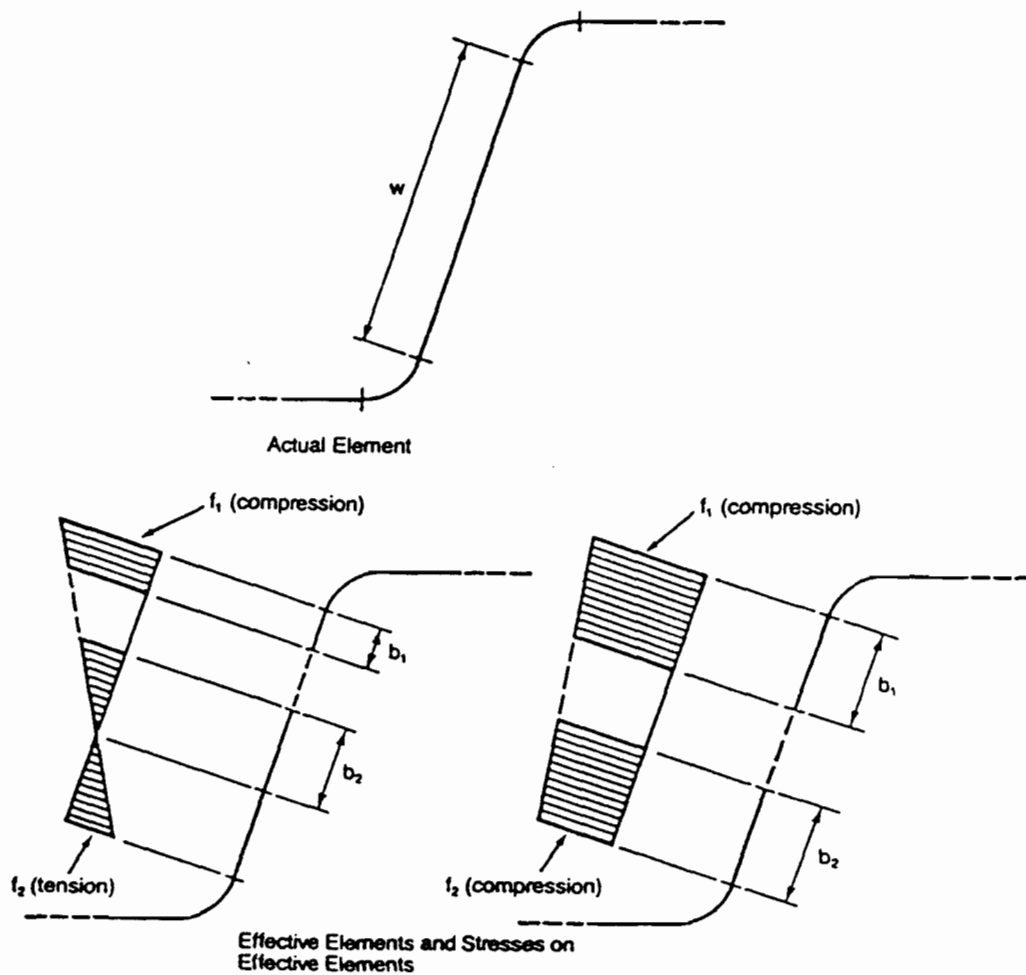

Figure B2.3-1 Stiffened Elements with Stress Gradient and Webs

(b) Deflection Determination

The effective widths in computing deflections at a given load shall be determined in accordance with Section B2.3a except that  $f_{d1}$  and  $f_{d2}$  are substituted for  $f_1$  and  $f_2$  where  $f_{d1}$ ,  $f_{d2}$  = Computed stresses  $f_1$  and  $f_2$  as shown in Figure B2.3-1. Calculations are



based on the effective section at the load for which deflections are determined.

### B3 Effective Widths of Unstiffened Elements

#### B3.1 Uniformly Compressed Unstiffened Elements

##### (a) Load Capacity Determination

Effective widths,  $b$ , of unstiffened compression elements with uniform compression shall be determined in accordance with Section B2.1a with the exception that  $k$  shall be taken as 0.43 and  $w$  as defined in Figure B3.1-1.

##### (b) Deflection Determination

The effective widths used in computing deflection shall be determined in accordance with Procedure I of Section B2.1b except that  $f_d$  is substituted for  $f$  and  $k = 0.43$ .

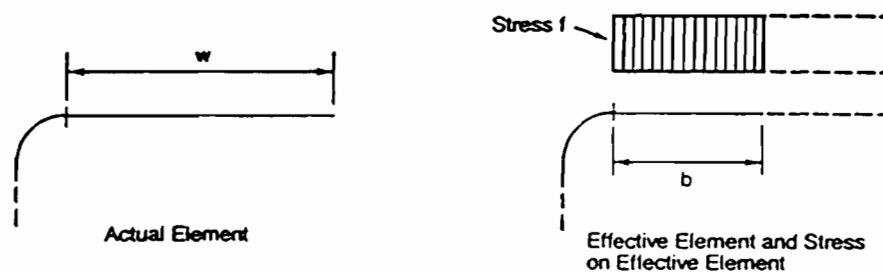

Figure B3.1-1 Unstiffened Element with Uniform Compression

### B3.2 Unstiffened Elements and Edge Stiffeners with Stress Gradient

#### (a) Load Capacity Determination

Effective widths,  $b$ , of unstiffened compression elements and edge stiffeners with stress gradient shall be determined in accordance with Section B2.1a with  $f = f_3$  as in Figure B4-2 in the element and  $k = 0.43$ .

#### (b) Deflection Determination

Effective widths,  $b$ , of unstiffened compression elements and edge stiffeners with stress gradient shall be determined in accordance with Procedure I of Section B2.1b except that  $f_{d3}$  is substituted for  $f$  and  $k = 0.43$ .

### B4 Effective Widths of Elements with an Edge Stiffener or One Intermediate Stiffener

The following notation is used in this section.

- $S$  =  $1.28\sqrt{E/f}$  (Eq. B4-1)
- $k$  = Buckling coefficient
- $b_o$  = Dimension defined in Figure B4-1
- $d, w, D$  = Dimensions defined in Figure B4-2
- $d_s$  = Reduced effective width of the stiffener as specified in this section.  $d_s$ , calculated according to Section B4.2, is to be used in computing the overall effective section properties (see Figure B4-2)
- $d'_s$  = Effective width of the stiffener calculated according to Section B3.1 (see Figure B4-2)
- $C_1, C_2$  = Coefficients defined in Figures B4-1 and B4-2
- $A_s$  = Reduced area of the stiffener as specified in this section.

$A_s$  is to be used in computing the overall effective section properties. The centroid of the stiffener is to be considered located at the centroid of the full area of the stiffener, and the moment of inertia of the stiffener about its own centroidal axis shall be that of the full section of the stiffener.

$I_a$  = Adequate moment of inertia of stiffener, so that each component element will behave as a stiffened element.

$I_s, A'_s$  = Moment of inertia of the full stiffener about its own centroidal axis parallel to the element to be stiffened and the effective area of the stiffener, respectively. For edge stiffeners the round corner between the stiffener and the element to be stiffened shall not be considered as a part of the stiffener.

For the stiffener shown in Figure B4-2,

$$I_s = (d^3 t \sin^2 \theta) / 12 \quad (\text{Eq. B4-2})$$

$$A'_s = d'_s t \quad (\text{Eq. B4-3})$$

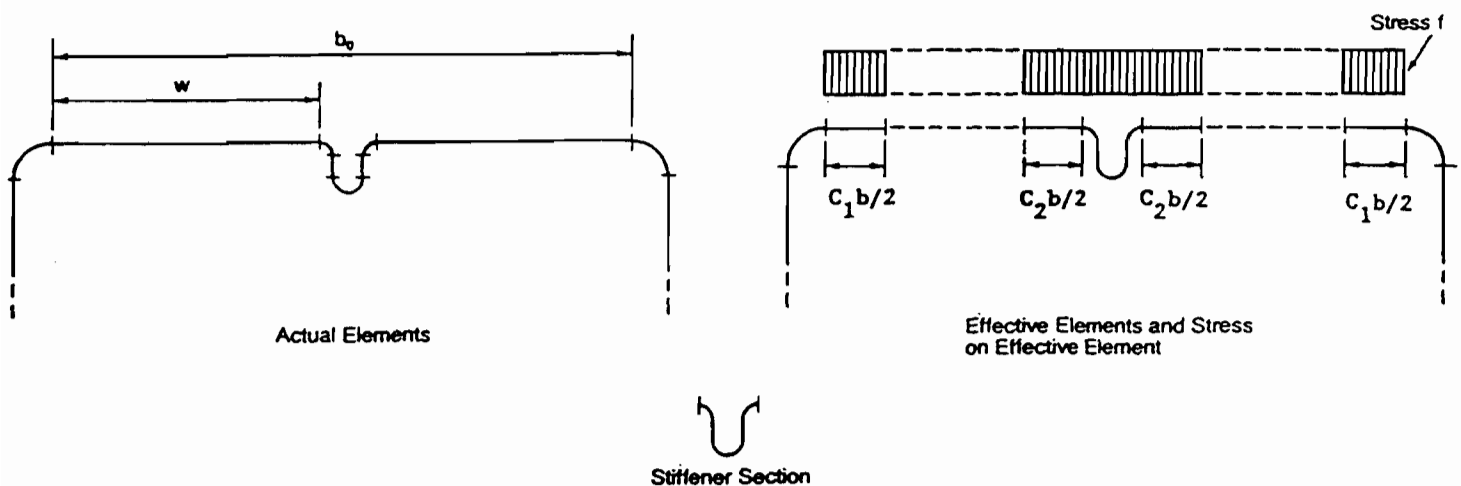

Figure B4-1 Elements with Intermediate Stiffener

## B4.1 Uniformly Compressed Elements with an Intermediate Stiffener

### (a) Load Capacity Determination

Case I:  $b_o/t \leq S$  (Eq. B4.1-1)

$I_a = 0$  (no intermediate stiffener needed) (Eq. B4.1-2)

$b = w$  (Eq. B4.1-3)

$A_s = A'_s$  (Eq. B4.1-4)

Case II:  $S < b_o/t < 3S$  (Eq. B4.1-5)

$I_a/t^4 = [50(b_o/t)/S] - 50$  (Eq. B4.1-6)

$b$  and  $A_s$  are calculated according to Section B2.1a where

$k = 3(I_s/I_a)^{1/2} + 1 \leq 4$  (Eq. B4.1-7)

$A_s = A'_s (I_s/I_a) \leq A'_s$  (Eq. B4.1-8)

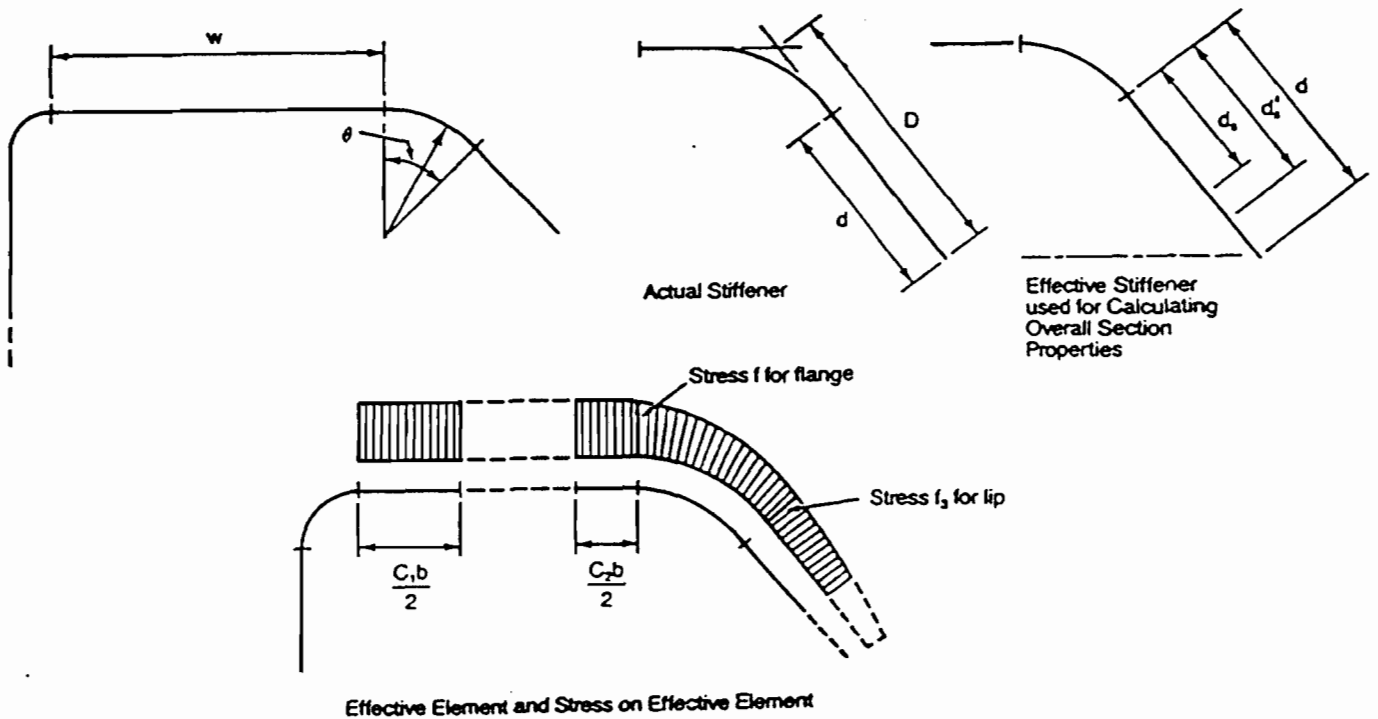

Figure B4-2 Elements with Edge Stiffener

Case III:  $b_o/t \geq 3S$

$$I_a/t^4 = [128(b_o/t)/S] - 285 \quad (\text{Eq. B4.1-9})$$

$b$  and  $A_s$  are calculated according to Section B2.1a where

$$k = 3(I_s/I_a)^{1/3} + 1 \leq 4 \quad (\text{Eq. B4.1-10})$$

$$A_s = A'_s (I_s/I_a) \leq A'_s \quad (\text{Eq. B4.1-11})$$

(b) Deflection Determination

Effective widths shall be determined as in Section B4.1a except that  $f_d$  is substituted for  $f$ .

#### B4.2 Uniformly Compressed Elements with an Edge Stiffener

(a) Load Capacity Determination

Case I:  $w/t \leq S/3$  (Eq. B4.2-1)

$$I_a = 0 \text{ (no edge stiffener needed)} \quad (\text{Eq. B4.2-2})$$

$$b = w \quad (\text{Eq. B4.2-3})$$

$$d_s = d'_s \text{ for simple lip stiffener} \quad (\text{Eq. B4.2-4})$$

$$A_s = A'_s \text{ for other stiffener shapes} \quad (\text{Eq. B4.2-5})$$

Case II:  $S/3 < w/t < S$

$$I_a/t^4 = 399[(w/t)/S - 0.33]^3 \quad (\text{Eq. B4.2-6})$$

$$n = 1/2$$

$$C_2 = I_s/I_a \leq 1 \quad (\text{Eq. B4.2-7})$$

$$C_1 = 2 - C_2 \quad (\text{Eq. B4.2-8})$$

$b$  shall be calculated according to Section B2.1 where

$$k = [4.82 - 5(D/w)](I_s/I_a)^{n+0.43} \leq 5.25 - 5(D/w) \quad (\text{Eq. B4.2-9})$$

for  $0.8 \geq D/w > 0.25$

$$k = 3.57(I_s/I_a)^{n+0.43} \leq 4.0 \quad (\text{Eq. B4.2-10})$$

for  $(D/w) \leq 0.25$

$$d_s = d'_s (I_s/I_a) \leq d'_s \quad (\text{Eq. B4.2-11})$$

for simple lip stiffener

$$A_s = A'_s (I_s/I_a) \leq A'_s \quad (\text{Eq. B4.2-12})$$

for other stiffener shape

Case III:  $w/t \geq S$

$$I_a/t^4 = [115(w/t)/S] + 5 \quad (\text{Eq. B4.2-13})$$

$C_1, C_2, b, k, d_s, A_s$  are calculated per Case II with  $n = 1/3$

(b) Deflection Determination

Effective widths shall be determined as in Section B4.2a except that  $f_d$  is substituted for  $f$ .

#### B5 Effective Widths of Edge Stiffened Elements with Intermediate Stiffeners or Stiffened Elements with More Than One Intermediate Stiffener

For the determination of the effective width, the intermediate stiffener of an edge stiffened element or the stiffeners of a stiffened element with more than one stiffener shall be disregarded unless each intermediate stiffener has the minimum  $I_s$  as follows:

$$I_{\min} = [3.66\sqrt{(w/t)^2 - (0.136E/F_y)}]t^4 \quad (\text{Eq. B5-1})$$

but not less than  $18.4t^4$

where

$w/t$  = Width-thickness ratio of the larger stiffened sub-element

$I_s$  = Moment of inertia of the full stiffener about its own centroidal axis parallel to the element to be stiffened

(a) If the spacing of intermediate stiffeners between two webs is such that for the sub-element between stiffeners  $b < w$  as determined in Section B2.1, only two intermediate stiffeners (those nearest each web) shall be considered effective.

- (b) If the spacing of intermediate stiffeners between a web and an edge stiffener is such that for the sub-element between stiffeners  $b < w$  as determined in Section B2.1, only one intermediate stiffener, that nearest the web, shall be considered effective.
- (c) If intermediate stiffeners are spaced so closely that for the elements between stiffeners  $b = w$  as determined in Section B2.1, all the stiffeners may be considered effective. In computing the flat-width to thickness ratio of the entire multiple-stiffened element, such element shall be considered as replaced by an "equivalent element" without intermediate stiffeners whose width,  $b_o$ , is the full width between webs or from web to edge stiffener, and whose equivalent thickness,  $t_s$ , is determined as follows:

$$t_s = \sqrt[3]{12I_{sf}/b_o} \quad (\text{Eq. B5-2})$$

where

$I_{sf}$  = Moment of inertia of the full area of the multiple-stiffened element, including the intermediate stiffeners, about its own centroidal axis. The moment of inertia of the entire section shall be calculated assuming the "equivalent element" to be located at the centroidal axis of the multiple stiffened element, including the intermediate stiffener. The actual extreme fiber distance shall be used in computing the section modulus.

- (d) If  $w/t > 60$ , the effective width,  $b_e$ , of the sub-element or element shall be determined from the following formula:

$$b_e/t = b/t - 0.10(w/t - 60) \quad (\text{Eq. B5-3})$$

where

$w/t$  = flat-width ratio of sub-element or element

$b$  = effective design width determined in accordance with the

provisions of Section B2.1

$b_e$  = effective design width of sub-element or element to be used  
in design computations

For computing the effective structural properties of a member having compression sub-elements or element subjected to the above reduction in effective width, the area of stiffeners (edge stiffener or intermediate stiffeners) shall be considered reduced to an effective area as follows:

For  $60 < w/t < 90$ :

$$A_{ef} = \alpha A_{st} \quad (\text{Eq. B5-4})$$

where

$$\alpha = (3 - 2b_e/w) - (1/30)(1 - b_e/w)(w/t) \quad (\text{Eq. B5-5})$$

For  $w/t \geq 90$ :

$$A_{ef} = (b_e/w)A_{st} \quad (\text{Eq. B5-6})$$

In the above expressions,  $A_{ef}$  and  $A_{st}$  refer only to the area of the stiffener section, exclusive of any portion of adjacent elements.

The centroid of the stiffener is to be considered located at the centroid of the full area of the stiffener, and the moment of inertia of the stiffener about its own centroidal axis shall be that of the full section of the stiffener.

## B6 Stiffeners

### B6.1 Transverse Stiffeners

Transverse stiffeners attached to beam webs at points of concentrated loads or reactions, shall be designed as compression members. Concentrated loads or reactions shall be applied directly into the stiffeners, or each stiffener shall be fitted accurately to the flat portion of the flange to



provide direct load bearing into the end of the stiffener. Means for shear transfer between the stiffener and the web shall be provided according to Chapter E. Required strengths for the concentrated loads or reactions shall not exceed the design strength,  $\phi_c P_n$ , where  $\phi_c = 0.85$  and  $P_n$  is the smaller value given by (a) and (b) as follows:

$$(a) \quad P_n = F_{wy} A_c \quad (\text{Eq. B6.1-1})$$

$$(b) \quad P_n = \text{Nominal axial strength evaluated according to Section C4(a)} \\ \text{with } A_e \text{ replaced by } A_b$$

where

$$A_c = 18t^2 + A_s, \text{ for transverse stiffeners at interior support and} \\ \text{under concentrated load} \quad (\text{Eq. B6.1-2})$$

$$A_c = 10t^2 + A_s, \text{ for transverse stiffeners at end support} \quad (\text{Eq. B6.1-3})$$

$$F_{wy} = \text{Lower value of beam web, } F_y \text{ or stiffener section, } F_{ys}$$

$$A_b = b_1 t + A_s, \text{ for transverse stiffeners at interior support and} \\ \text{under concentrated load} \quad (\text{Eq. B6.1-4})$$

$$A_b = b_2 t + A_s, \text{ for transverse stiffeners at end support} \quad (\text{Eq. B6.1-5})$$

$$A_s = \text{Cross sectional area of transverse stiffeners}$$

$$b_1 = 25t[0.0024(L_{st}/t) + 0.72] \leq 25t \quad (\text{Eq. B6.1-6})$$

$$b_2 = 12t[0.0044(L_{st}/t) + 0.83] \leq 12t \quad (\text{Eq. B6.1-7})$$

$$L_{st} = \text{Length of transverse stiffener}$$

$$t = \text{Base thickness of beam web}$$

The  $w/t_s$  ratio for the stiffened and unstiffened elements of cold-formed steel transverse stiffeners shall not exceed  $1.28\sqrt{(E/F_{ys})}$  and  $0.37\sqrt{(E/F_{ys})}$  respectively, where  $F_{ys}$  is the yield stress,  $F_y$ , and  $t_s$  the thickness of the stiffener steel.

Where shear stiffeners are required, the spacing shall be such that the required shear strength shall not exceed the design shear strength,  $\phi_v V_n$ , permitted by Section C3.2, and the ratio  $a/h$  shall not exceed  $[260/(h/t)]^2$  nor 3.0.

The actual moment of inertia,  $I_s$ , of a pair of attached shear stiffeners, or of a single shear stiffener, with reference to an axis in the plane of the web, shall have a minimum value of

$$I_{smin} = 5ht^3[h/a - 0.7(a/h)] \geq (h/50)^4 \quad (\text{Eq. B6.2-1})$$

The gross area of shear stiffeners shall be not less than

$$A_{st} = [(1 - C_v)/2] \{a/h - (a/h)^2 / [(a/h) + \sqrt{1 + (a/h)^2}]\} YDht \quad (\text{Eq. B6.2-2})$$

where

$$C_v = 45,000k_v / [F_y(h/t)^2] \quad \text{when } C_v \leq 0.8 \quad (\text{Eq. B6.2-3})$$

$$C_v = [190/(h/t)] (\sqrt{k_v/F_y}) \quad \text{when } C_v > 0.8 \quad (\text{Eq. B6.2-4})$$

$$k_v = 4.00 + 5.34/(a/h)^2 \quad \text{when } a/h \leq 1.0 \quad (\text{Eq. B6.2-5})$$

$$k_v = 5.34 + 4.00/(a/h)^2 \quad \text{when } a/h > 1.0 \quad (\text{Eq. B6.2-6})$$

$a$  = Distance between transverse stiffeners

$Y$  = Yield point of web steel/Yield point of stiffener steel

$D$  = 1.0 for stiffeners furnished in pairs

$D$  = 1.8 for single-angle stiffeners

$D$  = 2.4 for single-plate stiffeners

$t$  and  $h$  are as defined in Section B1.2

### B6.3 Non-Conforming Stiffeners

The design strength of members with transverse stiffeners that do not meet the requirements of Section B6.1 or B6.2, such as stamped or rolled-in transverse stiffeners shall be determined by tests in accordance with Chapter F of this Specification.

## C. MEMBERS

### C1 Properties of Sections

Properties of sections (cross-sectional area, moment of inertia, section modulus, radius of gyration, etc.) shall be determined in accordance with conventional methods of structural design. Properties shall be based on the full cross section of the members (or net sections where the use of net section is applicable) except where the use of a reduced cross section, or effective design width, is required.

### C2 Tension Members

For axially loaded tension members, the design tensile strength,  $\phi_t T_n$ , shall be determined as follows:

$$\phi_t = 0.95$$

$$T_n = A_n F_y \quad (\text{Eq. C2-1})$$

where

$T_n$  = Nominal strength of member when loaded in tension

$\phi_t$  = Resistance factor for tension

$A_n$  = Net area of the cross section

$F_y$  = Design yield stress

For tension members using bolted connections, the design tensile strength shall also be limited by Section E3.2.

### C3 Flexural Members

#### C3.1 Strength for Bending Only

The design flexural strength,  $\phi_b M_n$ , shall be the smallest of the values calculated according to Sections C3.1.1, C3.1.2, and C3.1.3.

#### C3.1.1 Nominal Section Strength

The design flexural strength,  $\phi_b M_n$ , shall be determined with  $\phi_b = 0.95$  for sections with stiffened or partially stiffened compression flanges and 0.90 for sections with unstiffened compression flanges, and the nominal section strength,  $M_n$ , calculated either on the basis of initiation of yielding in the effective section (Procedure I) or on the basis of the inelastic reserve capacity (Procedure II) as applicable.

##### (a) Procedure I - Based on Initiation of Yielding

Effective yield moment based on section strength,  $M_n$ , shall be determined as follows:

$$M_n = S_e F_y \quad (\text{Eq. C3.1.1-1})$$

where

$F_y$  = Design yield stress as determined in Section A5.2.1

$S_e$  = Elastic section modulus of the effective section calculated with the extreme compression or tension fiber at  $F_y$

##### (b) Procedure II - Based on Inelastic Reserve Capacity

The inelastic flexural reserve capacity may be used when the following conditions are met:

- (1) The member is not subject to twisting or to lateral, torsional, or torsional-flexural buckling.
- (2) The effect of cold forming is not included in determining the yield point  $F_y$ .
- (3) The ratio of the depth of the compressed portion of the web to its thickness does not exceed  $\lambda_1$ .

(4) The shear force does not exceed  $0.35F_y$  times the web area,  $h \times t$ .

(5) The angle between any web and the vertical does not exceed 30 degrees.

The nominal flexural strength,  $M_n$ , shall not exceed either  $1.25S_e F_y$  determined according to Procedure I or that causing a maximum compression strain of  $C_y e_y$  (no limit is placed on the maximum tensile strain).

where

$e_y$  = Yield strain =  $F_y/E$

$E$  = Modulus of elasticity

$C_y$  = Compression strain factor determined as follows:

(a) Stiffened compression elements without intermediate stiffeners

$$C_y = 3 \text{ for } w/t \leq \lambda_1$$

$$C_y = 3 - 2[(w/t - \lambda_1)/(\lambda_2 - \lambda_1)] \text{ for } \lambda_1 < w/t < \lambda_2$$

$$C_y = 1 \text{ for } w/t \geq \lambda_2$$

where

$$\lambda_1 = 1.11/\sqrt{F_y/E} \quad (\text{Eq. C3.1.1-2})$$

$$\lambda_2 = 1.28/\sqrt{F_y/E} \quad (\text{Eq. C3.1.1-3})$$

(b) Unstiffened compression elements

$$C_y = 1$$

(c) Multiple-stiffened compression elements and compression elements with edge stiffeners

$$C_y = 1$$

When applicable, effective design widths shall be used in calculating section properties.  $M_n$  shall be calculated considering equilibrium of stresses, assuming an ideally elastic-plastic stress-strain curve which is the same in tension as in compression, assuming small deformation and

assuming that plane sections remain plane during bending. Combined bending and web crippling shall be checked by provisions of Section C3.5.

### C3.1.2 Lateral Buckling Strength

The design strength of the laterally unbraced segments of doubly- or singly-symmetric sections\* subjected to lateral buckling,  $\phi_b M_n$ , shall be determined with  $\phi_b = 0.90$  and  $M_n$  calculated as follows:

$$M_n = S_c(M_c/S_f) \quad (\text{Eq. C3.1.2-1})$$

where

$S_f$  = Elastic section modulus of the full unreduced section for the extreme compression fiber

$S_c$  = Elastic section modulus of the effective section calculated at a stress  $M_c/S_f$  in the extreme compression fiber

$M_c$  = Critical moment calculated according to (a) or (b) below:

(a) For I- or Z-sections bent about the centroidal axis (x-axis) perpendicular to the web:

For  $M_e \geq 2.78M_y$

$$M_c = M_y \quad (\text{Eq. C3.1.2-2})$$

For  $2.78M_y > M_e > 0.56M_y$

$$M_c = (10/9)M_y(1 - 10M_y/36M_e) \quad (\text{Eq. C3.1.2-3})$$

---

\* The provisions of this Section apply to I-, Z-, C- and other singly-symmetric section flexural members (not including multiple-web deck, U- and closed box-type members, and curved or arch members). The provisions of this Section do not apply to laterally unbraced compression flanges of otherwise laterally stable sections. Refer to Section C3.1.3 for C- and Z-purlins in which the tension flange is attached to sheathing.

For  $M_e \leq 0.56M_y$

$$M_c = M_e \quad (\text{Eq. C3.1.2-4})$$

where

$M_y$  = Moment causing initial yield at the extreme compression fiber  
of the full section

$$= S_f F_y \quad (\text{Eq. C3.1.2-5})$$

$M_e$  = Elastic critical moment determined either as defined in (b)  
below or as follows:

$$= \pi^2 E C_b d I_{yc} / (L^2) \text{ for doubly-symmetric I-sections} \quad (\text{Eq. C3.1.2-6})$$

$$= \pi^2 E C_b d I_{yc} / (2L^2) \text{ for point-symmetric Z-sections} \quad (\text{Eq. C3.1.2-7})$$

$L$  = Unbraced length of the member

$I_{yc}$  = Moment of inertia of the compression portion of a section about  
the gravity axis of the entire section parallel to the web, using  
the full unreduced section

Other terms are defined in (b) below.

(b) For singly-symmetric sections (x-axis is assumed to be the axis of  
symmetry):

For  $M_e > 0.5M_y$

$$M_c = M_y (1 - M_y / 4M_e) \quad (\text{Eq. C3.1.2-8})$$

For  $M_e \leq 0.5M_y$

$$M_c = M_e \quad (\text{Eq. C3.1.2-9})$$

where

$M_y$  is as defined in (a) above

$M_e$  = Elastic critical moment

$M_e = C_b r_0 A \sqrt{\sigma_{ey} \sigma_t}$  for bending about the symmetry axis (x-axis  
is the axis of symmetry oriented such that the shear center  
has a negative x-coordinate).

Alternatively,  $M_e$  can be calculated using the formula  
for doubly-symmetric I-sections given in (a) above

(Eq. C3.1.2-10)

$$M_e = C_s A \sigma_{ex} [j + C_s \sqrt{j^2 + r_0^2 (\sigma_t / \sigma_{ex})}] / C_{TF}$$

for bending about the centroidal axis perpendicular to  
the symmetry axis

(Eq. C3.1.2-11)

$C_s = + 1$  for moment causing compression on the shear center  
side of the centroid

$C_s = - 1$  for moment causing tension on the shear center side  
of the centroid

$$\sigma_{ex} = \pi^2 E / (K_x L_x / r_x)^2 \quad (\text{Eq. C3.1.2-12})$$

$$\sigma_{ey} = \pi^2 E / (K_y L_y / r_y)^2 \quad (\text{Eq. C3.1.2-13})$$

$$\sigma_t = 1 / (A r_0^2) [GJ + \pi^2 E C_w / (K_t L_t)^2] \quad (\text{Eq. C3.1.2-14})$$

$A$  = Full cross-sectional area

$C_b$  = Bending coefficient which can conservatively be taken as  
unity, or calculated from

$$C_b = 1.75 + 1.05(M_1/M_2) + 0.3(M_1/M_2)^2 \leq 2.3$$

where

$M_1$  is the smaller and  $M_2$  the larger bending moment at the  
ends of the unbraced length, taken about the strong axis of  
the member, and where  $M_1/M_2$ , the ratio of end moments, is  
positive when  $M_1$  and  $M_2$  have the same sign (reverse curvature  
bending) and negative when they are of opposite sign (single  
curvature bending). When the bending moment at any point  
within an unbraced length is larger than that at both ends  
of this length, and for members subject to combined axial



load and bending moment (Section C5),  $C_b$  shall be taken as unity.

$E$  = Modulus of elasticity

$d$  = Depth of section

$C_{TF} = 0.6 - 0.4(M_1/M_2)$

where

$M_1$  is the smaller and  $M_2$  the larger bending moment at the ends of the unbraced length, and where  $M_1/M_2$ , the ratio of end moments, is positive when  $M_1$  and  $M_2$  have the same sign (reverse curvature bending) and negative when they are of opposite sign (single curvature bending). When the bending moment at any point within an unbraced length is larger than that at both ends of this length, and for members subject to combined axial load and bending moment (Section C5),  $C_{TF}$  shall be taken as unity.

$r_0$  = Polar radius of gyration of the cross section about the shear center

$$= \sqrt{r_x^2 + r_y^2 + x_0^2} \quad (\text{Eq. C3.1.2-15})$$

$r_x, r_y$  = Radii of gyration of the cross section about the centroidal principal axes

$G$  = Shear modulus

$K_x, K_y, K_t$  = Effective length factors for bending about the x- and y-axes, and for twisting

$L_x, L_y, L_t$  = Unbraced lengths of compression member for bending about the x- and y-axes, and for twisting

$x_0$  = Distance from the shear center to the centroid along the principal x-axis, taken as negative

$$\begin{aligned}
J &= \text{St. Venant torsion constant of the cross section} \\
C_w &= \text{Torsional warping constant of the cross section} \\
j &= 1/(2I_y)(\int_A x^3 dA + \int_A xy^2 dA) - x_0 \quad (\text{Eq. C3.1.2-16})
\end{aligned}$$

### C3.1.3 Beams Having One Flange Through-Fastened to Deck or Sheathing

This section does not apply to a continuous beam between inflection points adjacent to a support.

The design flexural strength,  $\phi_b M_n$ , of a C- or Z-section loaded in a plane parallel to the web and with the tension flange attached to deck or sheathing and with compression flange laterally unbraced shall be determined with  $\phi_b = 0.90$  and the nominal flexural strength,  $M_n$ , calculated as follows:

$$M_n = R S_e F_y \quad (\text{Eq. C3.1.3-1})$$

where

- R = 0.40 for simple span C-sections
- = 0.50 for simple span Z-sections
- = 0.60 for continuous span C-sections
- = 0.70 for continuous span Z-sections

$S_e$  and  $F_y$  are defined in Section C3.1.1

The reduction factor, R, shall be limited to roof systems meeting the following conditions:

- (1) Member depth shall be less than 11.5 inches
- (2) The flanges shall be edge stiffened compression elements
- (3)  $60 \leq \text{depth/thickness} \leq 170$
- (4)  $2.8 \leq \text{depth/flange width} \leq 4.5$
- (5)  $16 \leq \text{flat width/thickness of flange} \leq 43$
- (6) Lap length in each direction (distance from center of support to

end of lap) shall not be less than:

1.5d for Z-sections

3.0d for C-sections

- (7) Member span length shall be no greater than 33 feet
- (8) For continuous span systems, the longest member span shall not be more than 20% greater than the shortest span
- (9) Both flanges shall be prevented from moving laterally at the supports
- (10) Roof or wall panels shall be steel sheets, minimum of 0.019" coated thickness, having a minimum rib depth of 1 in., spaced 12 in. on centers and attached in a manner to effectively inhibit relative movement between the panel and purlin flange
- (11) Insulation shall be glass fiber blanket 0 to 6 inches thick compressed between the member and panel in a manner consistent with the fastener being used
- (12) Fastener type shall be minimum No. 12 self-drilling or self-tapping sheet metal screws or 3/16 - in. rivets, washers 1/2 in. diameter
- (13) Fasteners shall not be standoff type screws
- (14) Fasteners shall be spaced not greater than 12 in. on centers and placed near the center of the beam flange

If variables fall outside any of the above stated limits, the user must perform full scale tests in accordance with Section F1 of the Specification, or apply another rational analysis procedure. In any case, the user may perform tests, in accordance with Section F1, as an alternate to the procedure described in this section.

### C3.2 Strength for Shear Only

The design shear strength,  $\phi_v V_n$ , at any section shall be calculated as follows:

(a) For  $h/t \leq \sqrt{Ek_v/F_y}$

$$\phi_v = 1.0$$

$$V_n = 0.577F_y h t \quad (\text{Eq. C3.2-1})$$

(b) For  $\sqrt{Ek_v/F_y} < h/t \leq 1.415\sqrt{Ek_v/F_y}$

$$\phi_v = 0.90$$

$$V_n = 0.64t^2 \sqrt{k_v F_y E} \quad (\text{Eq. C3.2-2})$$

(c) For  $h/t > 1.415\sqrt{Ek_v/F_y}$

$$\phi_v = 0.90$$

$$V_n = 0.905Ek_v t^3/h \quad (\text{Eq. C3.2-3})$$

where

$\phi_v$  = Resistance factor for shear

$V_n$  = Nominal shear strength of the beam

$t$  = Web thickness

$h$  = Depth of the flat portion of the web measured along the plane of the web

$k_v$  = Shear buckling coefficient determined as follows:

1. For unreinforced webs,  $k_v = 5.34$

2. For beam webs with transverse stiffeners satisfying the requirements of Section B6

when  $a/h \leq 1.0$

$$k_v = 4.00 + 5.34/(a/h)^2 \quad (\text{Eq. C3.2-4})$$

when  $a/h > 1.0$

$$k_v = 5.34 + 4.00/(a/h)^2 \quad (\text{Eq. C3.2-5})$$

where

$a$  = the shear panel length for unreinforced web element

= distance between transverse stiffeners for web elements

For a web consisting of two or more sheets, each sheet shall be considered as a separate element carrying its share of the shear force.

### C3.3 Strength for Combined Bending and Shear

For beams with unreinforced webs, the required flexural strength,  $M_u$ , and the required shear strength,  $V_u$ , shall satisfy the following interaction equation:

$$(M_u/\phi_b M_n)^2 + (V_u/\phi_v V_n)^2 \leq 1.0 \quad (\text{Eq. C3.3-1})$$

For beams with transverse web stiffeners, the required flexural strength,  $M_u$ , and the required shear strength,  $V_u$ , shall not exceed  $\phi_b M_n$  and  $\phi_v V_n$ , respectively. When  $M_u/(\phi_b M_n) > 0.5$  and  $V_u/(\phi_v V_n) > 0.7$ , then  $M_u$  and  $V_u$  shall satisfy the following interaction equation:

$$0.6(M_u/\phi_b M_n) + (V_u/\phi_v V_n) \leq 1.3 \quad (\text{Eq. C3.3-2})$$

In the above equations:

$\phi_b$  = Resistance factor for bending (See Section C3.1)

$\phi_v$  = Resistance factor for shear (See Section C3.2)

$M_n$  = Nominal flexural strength determined according to Section C3.1.1  
when bending alone exists

$V_n$  = Nominal shear strength when shear alone exists

### C3.4 Web Crippling Strength

These provisions are applicable to webs of flexural members subject to concentrated loads or reactions, or the components thereof, acting perpendicular to the longitudinal axis of the member and in the plane of the web under consideration, and causing compressive stresses in the web.

To avoid crippling of unreinforced flat webs of flexural members having a flat width ratio,  $h/t$ , equal to or less than 200, required strength for the concentrated loads and reactions shall not exceed the values of  $\phi_w P_n$ , with  $\phi_w = 0.75$  and  $0.80$  for single unreinforced webs and I-sections, respectively, and  $P_n$  given in Table C3.4-1. Webs of flexural members for which  $h/t$  is greater than 200 shall be provided with adequate means of transmitting concentrated loads and/or reactions directly into the webs.

The formulas in Table C3.4-1 apply to beams when  $R/t \leq 6$  and to deck when  $R/t \leq 7$ ,  $N/t \leq 210$  and  $N/h \leq 3.5$ .

$P_n$  represents the nominal strength for concentrated load or reaction for one solid web connecting top and bottom flanges. For two or more webs,  $P_n$  shall be computed for each individual web and the results added to obtain the nominal load or reaction for the multiple web.

For build-up I-sections, or similar sections, the distance between the web connector and beam flange shall be kept as small as practical.

TABLE C3.4-1

$$P_n$$

		Shapes Having Single Webs		I-Sections or Similar Sections <sup>(1)</sup>
		Stiffened or Partially Stiffened Flanges	Unstiffened Flanges	Stiffened, Partially Stiffened and Unstiffened Flanges
Opposing loads Spaced $>1.5h$ <sup>(2)</sup>	End Reaction <sup>(3)</sup>	Eq. C3.4-1	Eq. C3.4-2	Eq. C3.4-3
	Interior Reaction <sup>(4)</sup>	Eq. C3.4-4	Eq. C3.4-4	Eq. C3.4-5
Opposing Loads Spaced $\leq 1.5h$ <sup>(5)</sup>	End Reaction <sup>(3)</sup>	Eq. C3.4-6	Eq. C3.4-6	Eq. C3.4-7
	Interior Reaction <sup>(4)</sup>	Eq. C3.4-8	Eq. C3.4-8	Eq. C3.4-9

Footnotes and Equation References to Table C3.4-1:

- (1) I-sections made of two channels connected back to back or similar sections which provide a high degree of restraint against rotation of the web (such as I-sections made by welding two angles to a channel).
- (2) At locations of one concentrated load or reaction acting either on the top or bottom flange, when the clear distance between the bearing edges of this and adjacent opposite concentrated loads or reactions is greater than  $1.5h$ .
- (3) For end reactions of beams or concentrated loads on the end of cantilevers when the distance from the edge of the bearing to the end of the beam is less than  $1.5h$ .
- (4) For reactions and concentrated loads when the distance from the edge of bearing to the end of the beam is equal to or greater than  $1.5h$ .
- (5) At locations of two opposite concentrated loads or of a concentrated

load and an opposite reaction acting simultaneously on the top and bottom flanges, when the clear distance between their adjacent bearing edges is equal to or less than 1.5h.

Equations for Table C3.4-1:

$$t^2kC_3C_4C_\theta [331-0.61(h/t)] [1+0.01(N/t)] \quad (\text{Eq. C3.4-1})$$

$$t^2kC_3C_4C_\theta [217-0.28(h/t)] [1+0.01(N/t)] \quad (\text{Eq. C3.4-2})$$

when  $N/t > 60$ , the factor  $[1+0.01(N/t)]$  may be increased to  $[0.71+0.015(N/t)]$

$$t^2F_yC_6(10+1.25\sqrt{N/t}) \quad (\text{Eq. C3.4-3})$$

$$t^2kC_1C_2C_\theta [538-0.74(h/t)] [1+0.007(N/t)] \quad (\text{Eq. C3.4-4})$$

when  $N/t > 60$ , the factor  $[1+0.007(N/t)]$  may be increased to  $[0.75+0.011(N/t)]$

$$t^2F_yC_5(0.88+0.12m)(15+3.25\sqrt{N/t}) \quad (\text{Eq. C3.4-5})$$

$$t^2kC_3C_4C_\theta [244-0.57(h/t)] [1+0.01(N/t)] \quad (\text{Eq. C3.4-6})$$

$$t^2F_yC_8(0.64+0.31m)(10+1.25\sqrt{N/t}) \quad (\text{Eq. C3.4-7})$$

$$t^2kC_1C_2C_\theta [771-2.26(h/t)] [1+0.0013(N/t)] \quad (\text{Eq. C3.4-8})$$

$$t^2F_yC_7(0.82+0.15m)(15+3.25\sqrt{N/t}) \quad (\text{Eq. C3.4-9})$$

In the above-referenced formulas,

$\Phi_w$  = Resistance factor for web crippling

$P_n$  = Nominal strength for concentrated load or reaction per web

$$C_1 = (1.22-0.22k) \quad (\text{Eq. C3.4-10})$$

$$C_2 = (1.06-0.06R/t) \leq 1.0 \quad (\text{Eq. C3.4-11})$$

$$C_3 = (1.33-0.33k) \quad (\text{Eq. C3.4-12})$$

$$C_4 = (1.15-0.15R/t) \leq 1.0 \text{ but not less than } 0.50 \quad (\text{Eq. C3.4-13})$$

$$C_5 = (1.49-0.53k) \geq 0.6 \quad (\text{Eq. C3.4-14})$$

$$C_6 = 1+(h/t)/750, \text{ when } h/t \leq 150 \quad (\text{Eq. C3.4-15})$$

$$= 1.20, \text{ when } h/t > 150 \quad (\text{Eq. C3.4-16})$$



$$C_7 = 1/k, \text{ when } h/t \leq 66.5 \quad (\text{Eq. C3.4-17})$$

$$= [1.10 - (h/t)/665](1/k), \text{ when } h/t > 66.5 \quad (\text{Eq. C3.4-18})$$

$$C_8 = [0.98 - (h/t)/865](1/k) \quad (\text{Eq. C3.4-19})$$

$$C_\theta = 0.7 + 0.3(\theta/90)^2 \quad (\text{Eq. C3.4-20})$$

$F_y$  = Design yield stress of the web, ksi

$h$  = Depth of the flat portion of the web measured along the plane of the web

$$k = F_y/33 \quad (\text{Eq. C3.4-21})$$

$$m = t/0.075 \quad (\text{Eq. C3.4-22})$$

$t$  = Web thickness, inches

$N$  = Actual length of bearing, inches. For the case of two equal and opposite concentrated loads distributed over unequal bearing lengths, the smaller value of  $N$  shall be taken

$R$  = Inside bend radius

$\theta$  = Angle between the plane of the web and the plane of the bearing surface  $\geq 45^\circ$ , but not more than  $90^\circ$

### C3.5 Combined Bending and Web Crippling Strength

Unreinforced flat webs of shapes subjected to a combination of bending and concentrated load or reaction shall be designed to meet the following requirements:

(a) For shapes having single unreinforced webs:

$$1.07(P_u/\phi_w P_n) + (M_u/\phi_b M_n) \leq 1.42 \quad (\text{Eq. C3.5-1})$$

Exception: At the interior supports of continuous spans, the above formula is not applicable to deck or beams with two or more single webs, provided the compression edges of adjacent webs are laterally supported in the negative moment region by continuous or intermittently connected flange

elements, rigid cladding, or lateral bracing, and the spacing between adjacent webs does not exceed 10 inches.

(b) For shapes having multiple unreinforced webs such as I-sections made of two channels connected back-to-back, or similar sections which provide a high degree of restraint against rotation of the web (such as I-sections made by welding two angles to a channel);

$$0.82(P_u/\phi_w P_n) + (M_u/\phi_b M_n) \leq 1.32 \quad (\text{Eq. C3.5-2})$$

Exception: When  $h/t \leq 2.33/\sqrt{(F_y/E)}$  and  $\lambda \leq 0.673$ , the nominal concentrated load or reaction strength may be determined by Section C3.4.

In the above formulas,

$\phi_b$  = Resistance factor for bending (See Section C3.1)

$\phi_w$  = Resistance factor for web crippling (See Section C3.4)

$P_u$  = Required strength for the concentrated load or reaction in the presence of bending moment.

$P_n$  = Nominal strength for concentrated load or reaction in the absence of bending moment determined in accordance with Section C3.4

$M_u$  = Required flexural strength at, or immediately adjacent to, the point of application of the concentrated load or reaction  $P_u$

$M_n$  = Nominal flexural strength determined according to Section C3.1.1 if bending alone exists

$w$  = Flat width of the beam flange which contacts the bearing plate

$t$  = Thickness of the web or flange

$\lambda$  = Slenderness factor given by Section B2.1

This section applies to members in which the resultant of all loads acting on the member is an axial load passing through the centroid of the effective section calculated at the stress,  $F_n$ , defined in this section.

(a) The design axial strength,  $\phi_c P_n$ , shall be calculated as follows:

$$\phi_c = 0.85$$

$$P_n = A_e F_n \quad (\text{Eq. C4-1})$$

where

$A_e$  = Effective area at the stress  $F_n$ . For sections with circular holes,  $A_e$  shall be determined according to Section B2.2a, subject to the limitations of that section. If the number of holes in the effective length region times the hole diameter divided by the effective length does not exceed 0.015,  $A_e$  can be determined ignoring the holes.

$F_n$  is determined as follows:

$$\text{For } F_e > F_y/2 \quad F_n = F_y(1 - F_y/4F_e) \quad (\text{Eq. C4-2})$$

$$\text{For } F_e \leq F_y/2 \quad F_n = F_e \quad (\text{Eq. C4-3})$$

$F_e$  is the least of the elastic flexural, torsional and torsional-flexural buckling stress determined according to Sections C4.1 through C4.3.

(b) For C- and Z-shapes, and single-angle sections with unstiffened flanges,  $P_n$  shall be taken as the smaller of  $P_n$  calculated above and

$P_n$  calculated as follows:

$$P_n = A n^2 E / \{25.7(w/t)^2\} \quad (\text{Eq. C4-4})$$

where

$A$  = Area of the full, unreduced cross section

$w$  = Flat width of the unstiffened element

$t$  = Thickness of the unstiffened element

- (c) Angle sections shall be designed for the required axial strength,  $P_u$ , acting simultaneously with a moment equal to  $P_u L/1000$  applied about the minor principal axis causing compression in the tips of the angle legs.
- (d) The slenderness ratio,  $KL/r$ , of all compression members preferably should not exceed 200, except that during construction only,  $KL/r$  preferably should not exceed 300.

#### C4.1 Sections Not Subject to Torsional or Torsional-Flexural Buckling

For doubly-symmetric sections, closed cross sections and any other sections which can be shown not to be subject to torsional or torsional-flexural buckling, the elastic flexural buckling stress,  $F_e$ , shall be determined as follows:

$$F_e = \pi^2 E / (KL/r)^2 \quad (\text{Eq. C4.1-1})$$

where

E = Modulus of elasticity

K = Effective length factor\*

L = Unbraced length of member

r = Radius of gyration of the full, unreduced cross section

---

\* In frames where lateral stability is provided by diagonal bracing, shear walls, attachment to an adjacent structure having adequate lateral stability, or floor slabs or roof decks secured horizontally by walls or bracing systems parallel to the plane of the frame, and in trusses, the effective length factor, K, for compression members which do not depend upon their own bending stiffness for lateral stability of the frame or truss, shall be taken as unity, unless analysis shows that a smaller value may be used. In a frame which depends upon its own bending stiffness for lateral stability, the effective length, KL, of the compression members shall be determined by a rational method and shall not be less than the actual unbraced length.

#### C4.2 Doubly- or Singly-Symmetric Sections Subject to Torsional or Torsional-Flexural Buckling

For sections subject to torsional or torsional-flexural buckling,  $F_e$  shall be taken as the smaller of  $F_e$  calculated according to Section C4.1 and  $F_e$  calculated as follows:

$$F_e = (1/2\beta)[(\sigma_{ex} + \sigma_t) - \sqrt{(\sigma_{ex} + \sigma_t)^2 - 4\beta\sigma_{ex}\sigma_t}] \quad (\text{Eq. C4.2-1})$$

Alternatively, a conservative estimate of  $F_e$  can be obtained using the following equation:

$$F_e = \sigma_t \sigma_{ex} / (\sigma_t + \sigma_{ex}) \quad (\text{Eq. C4.2-2})$$

where  $\sigma_t$  and  $\sigma_{ex}$  are defined in C3.1.2(b)

$$\beta = 1 - (x_0/r_0)^2 \quad (\text{Eq. C4.2-3})$$

For singly-symmetric sections, the x-axis is assumed to be the axis of symmetry.

#### C4.3 Nonsymmetric Sections

For shapes whose cross sections do not have any symmetry, either about an axis or about a point,  $F_e$  shall be determined by rational analysis. Alternatively, compression members composed of such shapes may be tested in accordance with Chapter F.

#### C5 Combined Axial Load and Bending

The required strengths  $P_u$ ,  $M_{ux}$  and  $M_{uy}$  shall satisfy the following interaction equations:

$$P_u / \phi_c P_n + C_{mx} M_{ux} / \phi_b M_{nx} \alpha_{nx} + C_{my} M_{uy} / \phi_b M_{ny} \alpha_{ny} \leq 1.0 \quad (\text{Eq. C5-1})$$

$$P_u / \phi_c P_n + M_{ux} / \phi_b M_{nx} + M_{uy} / \phi_b M_{ny} \leq 1.0 \quad (\text{Eq. C5-2})$$

When  $P_u / \phi_c P_n \leq 0.15$ , the following formula may be used in lieu of the above two formulas:

$$P_u / \phi_c P_n + M_{ux} / \phi_b M_{nx} + M_{uy} / \phi_b M_{ny} \leq 1.0 \quad (\text{Eq. C5-3})$$

where

$P_u$  = Required axial strength

$M_{ux}$  and  $M_{uy}$  = Required flexural strengths with respect to the centroidal axes of the effective section determined for the required axial strength alone. For angle sections,  $M_{uy}$  shall be taken either as the required flexural strength or the required flexural strength plus  $P_u L / 1000$ , whichever result in a lower value of  $P_n$ .

$P_n$  = Nominal axial strength determined in accordance with Section C4

$P_{no}$  = Nominal axial strength determined in accordance with Section C4, with  $F_n = F_y$

$M_{nx}$  and  $M_{ny}$  = Nominal flexural strengths about the centroidal axes determined in accordance with Section C3

$1/\alpha_{nx}$ ,  $1/\alpha_{ny}$  = Magnification factors  
 $= 1 / (1 - P_u / \phi_c P_E)$  (Eq. C5-4)

$\phi_b$  = 0.95 and 0.90 for bending strength (Section C3.1.1) or 0.90 for laterally unbraced beam (Section C3.1.2)

$\phi_c$  = 0.85

$P_E$  =  $\pi^2 EI_b / (K_b L_b)^2$  (Eq. C5-5)

$I_b$  = Moment of inertia of the full, unreduced cross section about the axis of bending

$L_b$  = Actual unbraced length in the plane of bending

$K_b$  = Effective length factor in the plane of bending

$C_{mx}$ ,  $C_{my}$  = Coefficients whose value shall be taken as follows:

1. For compression members in frames subject to joint

translation (sideways)

$$C_m = 0.85$$

2. For restrained compression members in frames braced against joint translation and not subject to transverse loading between their supports in the plane of bending

$$C_m = 0.6 - 0.4(M_1/M_2) \quad (\text{Eq. C5-6})$$

where

$M_1/M_2$  is the ratio of the smaller to the larger moment at the ends of that portion of the member under consideration which is unbraced in the plane of bending.

$M_1/M_2$  is positive when the member is bent in reverse curvature and negative when it is bent in single curvature.

3. For compression members in frames braced against joint translation in the plane of loading and subject to transverse loading between their supports, the value of  $C_m$  may be determined by rational analysis. However, in lieu of such analysis, the following values may be used:

(a) for members whose ends are restrained,  $C_m = 0.85$ ,

(b) for members whose ends are unrestrained,  $C_m = 1.0$ .

## C6 Cylindrical Tubular Members

The requirements of this Section apply to cylindrical tubular members having a ratio of outside diameter to wall thickness,  $D/t$ , not greater than  $0.441E/F_y$ .

### C6.1 Bending

For flexural members, the required flexural strength uncoupled from axial load, shear, and local concentrated forces or reactions shall not exceed  $\phi_b M_n$ , where  $\phi_b = 0.95$  and  $M_n$  is calculated as follows:

For  $D/t \leq 0.070E/F_y$

$$M_n = 1.25F_y S_f \quad (\text{Eq. C6.1-1})$$

For  $0.070E/F_y < D/t \leq 0.319E/F_y$

$$M_n = [0.970 + 0.020(E/F_y)/(D/t)]F_y S_f \quad (\text{Eq. C6.1-2})$$

For  $0.319E/F_y < D/t \leq 0.441E/F_y$

$$M_n = [0.328E/(D/t)]S_f \quad (\text{Eq. C6.1-3})$$

where

$S_f$  = Elastic section modulus of the full, unreduced cross section

## C6.2 Compression

The requirements of this Section apply to members in which the resultant of all factored loads and moments acting on the member is equivalent to a single force in the direction of the member axis passing through the centroid of the section.

The design axial strength,  $\phi_c P_n$ , shall be calculated as follows:

$$\phi_c = 0.85$$

$$P_n = F_n A_e \quad (\text{Eq. C6.2-1})$$

In the above equation,

For  $F_e > F_y/2$

$$\begin{aligned} F_n &= \text{Flexural buckling stress} \\ &= F_y(1 - F_y/4F_e) \end{aligned} \quad (\text{Eq. C6.2-2})$$

$F_e$  = Elastic flexural buckling stress determined according to Section C4.1

$$A_e = [1 - (1 - R^2)(1 - A_0/A)]A \quad (\text{Eq. C6.2-3})$$



$$R = \sqrt{F_y/2F_e} \quad (\text{Eq. C6.2-4})$$

$$A_0 = [0.037/(DF_y/tE)+0.667]A \leq A \text{ for } D/t \leq 0.441E/F_y \quad (\text{Eq. C6.2-5})$$

A = Area of the unreduced cross section

For  $F_e \leq F_y/2$

$$F_n = F_e$$

$$A_e = A$$

### C6.3 Combined Bending and Compression

Combined bending and compression shall satisfy the provisions of Section C5.

## D. STRUCTURAL ASSEMBLIES

### D1 Built-Up Sections

#### D1.1 I-Sections Composed of Two Channels

The maximum permissible longitudinal spacing of welds or other connectors,  $s_{\max}$ , joining two channels to form an I-section shall be

(a) For compression members:

$$s_{\max} = Lr_{cy}/(2r_I) \quad (\text{Eq. D1.1-1})$$

where

$L$  = Unbraced length of compression member

$r_I$  = Radius of gyration of the I-section about the axis perpendicular to the direction in which buckling would occur for the given conditions of end support and intermediate bracing

$r_{cy}$  = Radius of gyration of one channel about its centroidal axis parallel to the web

(b) For flexural members:

$$s_{\max} = L/6 \quad (\text{Eq. D1.1-2})$$

In no case shall the spacing exceed the value

$$s_{\max} = 2gT_s/(mq) \quad (\text{Eq. D1.1-3})$$

where

$L$  = Span of beam

$T_s$  = Design strength of connection in tension (Section E)

$g$  = Vertical distance between the two rows of connections nearest to the top and bottom flanges

$q$  = Intensity of factored load on the beam (For methods of determination, see below)

$m$  = Distance from the shear center of one channel to the mid-plane of its web. For simple channels without stiffening lips at the outer edges,

$$m = w_f^2 / (2w_f + d/3) \quad (\text{Eq. D1.1-4})$$

For channels with stiffening lips at the outer edges,

$$m = w_f dt / (4I_x) [w_f d + 2D(d - 4D^2/3d)] \quad (\text{Eq. D1.1-5})$$

$w_f$  = Projection of flanges from the inside face of the web (For channels with flanges of unequal width,  $w_f$  shall be taken as the width of the wider flange)

$d$  = Depth of channel or beam

$D$  = Overall depth of lip

$I_x$  = Moment of inertia of one channel about its centroidal axis normal to the web.

The intensity of factored load,  $q$ , is obtained by dividing the magnitude of factored concentrated loads or reactions by the length of bearing. For beams designed for a uniformly distributed load,  $q$  shall be taken equal to three times the intensity of the uniformly distributed factored load. If the length of bearing of a concentrated load or reaction is smaller than weld spacing,  $s$ , the required design strength of the welds or connections closest to the load or reaction is

$$T_s = Pm / (2g) \quad (\text{Eq. D1.1-6})$$

The required maximum spacing of connections,  $s_{max}$ , depends upon the intensity of the factored load directly at the connection. Therefore, if uniform spacing of connections is used over the whole length of the beam, it shall be determined at the point of maximum local load intensity. In cases where this procedure would result in uneconomically close spacing, either one of the following methods may be adopted: (a) the connection spacing may

be varied along the beam according to the variation of the load intensity; or (b) reinforcing cover plates may be welded to the flanges at points where concentrated loads occur. The design shear strength of the connections joining these plates to the flanges shall then be used for  $T_s$ , and  $g$  shall be taken as the depth of the beam.

#### D1.2 Spacing of Connections in Compression Elements

The spacing,  $s$ , in the line of stress, of welds, rivets, or bolts connecting a compression cover plate or sheet to a non-integral stiffener or other element shall not exceed

- (a) that which is required to transmit the shear between the connected parts on the basis of the design strength per connection specified elsewhere herein; nor
- (b)  $1.16t\sqrt{(E/f_c)}$ , where  $t$  is the thickness of the cover plate or sheet, and  $f_c$  is the stress at service load in the cover plate or sheet; nor
- (c) three times the flat width,  $w$ , of the narrowest unstiffened compression element tributary to the connections, but need not be less than  $1.11t\sqrt{(E/F_y)}$  if  $w/t < 0.50\sqrt{(E/F_y)}$ , or  $1.33t\sqrt{(E/F_y)}$  if  $w/t \geq 0.50\sqrt{(E/F_y)}$ , unless closer spacing is required by (a) or (b) above.

In the case of intermittent fillet welds parallel to the direction of stress, the spacing shall be taken as the clear distance between welds, plus one-half inch. In all other cases, the spacing shall be taken as the center-to-center distance between connections.

Exception: The requirements of this Section do not apply to cover sheets which act only as sheathing material and are not considered as load-carrying elements.

## D2 Mixed Systems

The design of members in mixed systems using cold-formed steel components in conjunction with other materials shall conform to this Specification and the applicable Specification of the other material.

## D3 Lateral Bracing

Braces shall be designed to restrain lateral bending or twisting of a loaded beam or column, and to avoid local crippling at the points of attachment.

### D3.1 Symmetrical Beams and Columns

Braces and bracing systems, including connections, shall be designed considering strength and stiffness requirements.

### D3.2 Channel-Section and Z-Section Beams

The following provisions for bracing to restrain twisting of channels and Z-sections used as beams loaded in the plane of the web, apply only when (a) the top flange is connected to deck or sheathing material in such a manner as to effectively restrain lateral deflection of the connected flange<sup>\*</sup>, or (b) neither flange is so connected. When both flanges are so connected, no further bracing is required.

---

\* Where the Specification does not provide an explicit method for design, further information should be obtained from the Commentary.

### D3.2.1 Anchorage of Bracing for Roof Systems Under Gravity Load With Top Flange Connected to Sheathing

For channels and Z-sections designed according to Section C3.1.1, and having deck or sheathing fastened directly to the top flanges in such a manner shown to effectively inhibit relative movement between the deck or sheathing and the purlin flange, provisions shall be made to restrain the flanges so that the maximum top flange lateral displacements with respect to the purlin reaction points do not exceed the span length divided by 360. If the top flanges of all purlins face in the same direction, anchorage of the restraint system must be capable of satisfying the requirements of Sections D3.2.1(a) and D3.2.1(b). If the top flanges of adjacent lines of purlins face in opposite directions, the provisions of Sections D3.2.1(a) and D3.2.1(b) do not apply.

Anchored braces need to be connected to only one line of purlins in each purlin bay of each roof slope if provision is made to transmit forces from other purlin lines through the roof deck and its fastening system. Anchored braces shall be as close as possible to the flange which is connected to the deck or sheathing. Anchored braces shall be provided for each purlin bay.

For bracing arrangements other than those covered in Sections D3.2.1(a) and D3.2.1(b), tests in accordance with Chapter F shall be performed so that the type and/or spacing of braces selected are such that the test strength of the braced Z-section assembly is equal to or greater than its nominal flexural strength, instead of that required by Chapter F.

#### (a) Channel Sections

For roof systems using channel sections for purlins with all compression flanges facing in the same direction, a restraint system capable of

resisting 0.05W, in addition to other loading, shall be provided where W is the factored load supported by all purlin lines being restrained. Where more than one brace is used at a purlin line, the restraint force 0.05W shall be divided equally between all braces.

(b) Z-Sections

For roof systems having a diaphragm stiffness of at least 2,000 lb/in., having four to twenty Z-purlin lines with all top flanges facing in the direction of the upward roof slope, and with restraint braces at the purlin supports, midspan or one-third points, each brace shall be designed to resist a force determined as follows:

(1) Single-Span System with Restraint at the Supports:

$$P_L = 0.5[0.220b^{1.50}/(n_p^{0.72}d^{0.90}t^{0.60})-\sin\theta]W \quad (\text{Eq. D3.2.1-1})$$

(2) Single-Span System with Third-Point Restraints:

$$P_L = 0.5[0.474b^{1.22}/(n_p^{0.57}d^{0.89}t^{0.33})-\sin\theta]W \quad (\text{Eq. D3.2.1-2})$$

(3) Single-Span System with Midspan Restraint:

$$P_L = [0.224b^{1.32}/(n_p^{0.65}d^{0.83}t^{0.50})-\sin\theta]W \quad (\text{Eq. D3.2.1-3})$$

(4) Multiple-Span System with Restraints at the Supports:

$$P_L = C_{tr}[0.053b^{1.88}L^{0.13}/(n_p^{0.95}d^{1.07}t^{0.94})-\sin\theta]W \quad (\text{Eq. D3.2.1-4})$$

with

$$C_{tr} = 0.63 \text{ for braces at end supports of multiple-span systems}$$

$$C_{tr} = 0.87 \text{ for braces at the first interior supports}$$

$$C_{tr} = 0.81 \text{ for all other braces}$$

(5) Multiple-Span System with Third-Point Restraints:

$$P_L = C_{th}[0.181b^{1.15}L^{0.25}/(n_p^{0.54}d^{1.11}t^{0.29})-\sin\theta]W \quad (\text{Eq. D3.2.1-5})$$

with

$$C_{th} = 0.57 \text{ for outer braces in exterior spans}$$

$$C_{th} = 0.48 \text{ for all other braces}$$

(6) Multiple-Span System with Midspan Restraints:

$$P_L = C_{ms} [0.116b^{1.32}L^{0.18} / (n_p^{0.70}d^{1.00}t^{0.50}) - \sin\theta]W \quad (\text{Eq. D3.2.1-6})$$

with

$C_{ms} = 1.05$  for braces in exterior spans

$C_{ms} = 0.90$  for all other braces

where

$b$  = Flange width, in.

$d$  = Depth of section, in.

$t$  = Thickness, in.

$L$  = Span length, in.

$\theta$  = Angle between the vertical and the plane of the web of the Z-section, degrees

$n_p$  = Number of parallel purlin lines

$W$  = Total factored load supported by the purlin lines between adjacent supports, pounds

The force,  $P_L$ , is positive when restraint is required to prevent movement of the purlin flanges in the upward roof slope direction.

For systems having less than four purlin lines, the brace force can be determined by taking 1.1 times the force found from Equations D3.2.1-1 through D3.2.1-6, with  $n_p = 4$ . For systems having more than twenty purlin lines, the brace force can be determined from Equations D3.2.1-1 through D3.2.1-6, with  $n_p = 20$ .

#### D3.2.2 Neither Flange Connected to Sheathing

Each intermediate brace, at the top and bottom flange, shall be designed to resist a required lateral force,  $P_L$ , determined as follows:

(a) For uniform loads,  $P_L = 1.5K'$  times the factored load within a



distance 0.5a each side of the brace.

- (b) For concentrated loads,  $P_L = 1.0K'$  times each factored concentrated load within a distance 0.3a each side of the brace, plus  $1.4K'(1-x/a)$  times each factored concentrated load located farther than 0.3a but not farther than 1.0a from the brace.

In the above formulas:

For channels and Z-sections:

x = Distance from the concentrated load to the brace

a = Distance between center line of braces

For channels:

$$K' = m/d \quad (\text{Eq. D3.2.2-1})$$

where

m = Distance from the shear center to the mid-plane of the web, as specified in Section D1.1

d = Depth of channel

For Z-sections:

$$K' = I_{xy}/I_x \quad (\text{Eq. D3.2.2-2})$$

where

$I_{xy}$  = Product of inertia of the full section about centroidal axes parallel and perpendicular to the web

$I_x$  = Moment of inertia of the full section about the centroidal axis perpendicular to the web

Braces shall be designed to avoid local crippling at the points of attachment to the member.

Braces shall be attached both to the top and bottom flanges of the sections, at the ends and at intervals not greater than one-quarter of the span length, in such a manner as to prevent tipping at the ends and

lateral deflection of either flange in either direction at intermediate braces. If one-third or more of the total factored load on the beam is concentrated over a length of one-twelfth or less of the span of the beam, an additional brace shall be placed at or near the center of this loaded length.

Exception: When all loads and reactions on a beam are transmitted through members which frame into the section in such a manner as to effectively restrain the section against rotation and lateral displacement, no other braces will be required.

#### D3.3 Laterally Unbraced Box Beams

For closed box-type sections used as beams subject to bending about the major axis, the ratio of the laterally unsupported length to the distance between the webs of the section shall not exceed  $0.086E/F_y$ .

#### D4 Wall Studs and Wall Stud Assemblies

The design strength of a stud may be computed on the basis that sheathing (attached to one or both sides of the stud) furnishes adequate lateral and rotational support to the stud in the plane of the wall, provided that the stud, sheathing, and attachments comply with the following requirements:

Both ends of the stud shall be braced to restrain rotation about the stud axis and horizontal displacement perpendicular to the stud axis; however, the ends may or may not be free to rotate about both axes perpendicular to the stud axis. The sheathing shall be connected to the top and bottom members of the wall assembly to enhance the restraint provided to the stud and stabilize the overall assembly.

#### D4.1 Wall Studs in Compression

For studs having identical sheathing attached to both flanges, and neglecting any rotational restraint provided by the sheathing<sup>\*</sup>, the design axial strength,  $\phi_c P_n$ , shall be calculated as follows:

$$\phi_c = 0.85$$

$$P_n = A_e F_n \quad (\text{Eq. D4.1-1})$$

where

$\phi_c$  = Resistance factor for axial compression

$A_e$  = Effective area determined at  $F_n$

$F_n$  = The lowest value determined by the following three conditions:

- (a) To prevent column buckling between fasteners in the plane of the wall,  $F_n$  shall be calculated according to Section C4 with KL equal to two times the distance between fasteners.
- (b) To prevent flexural and/or torsional overall column buckling,  $F_n$  shall be calculated in accordance with Section C4 with  $F_e$  taken as the smaller of the two  $\sigma_{CR}$  values specified for the following section types, where  $\sigma_{CR}$  is the theoretical elastic buckling stress under concentric loading.

---

\*Studs with sheathing on one flange only, or with unidentical sheathing on both flanges, or having rotational restraint that is not neglected, or having any combination of the above, shall be designed in accordance with the same basic analysis principles used in deriving the provisions of this Section.

(1) Singly-symmetric channels and C-Sections

$$\sigma_{CR} = \sigma_{ey} + \bar{Q}_a \quad (\text{Eq. D4.1-2})$$

$$\sigma_{CR} = 1/(2\beta) \left[ (\sigma_{ex} + \sigma_{tQ}) - \sqrt{(\sigma_{ex} + \sigma_{tQ})^2 - (4\beta\sigma_{ex}\sigma_{tQ})} \right] \quad (\text{Eq. D4.1-3})$$

(2) Z-Sections

$$\sigma_{CR} = \sigma_t + \bar{Q}_t \quad (\text{Eq. D4.1-4})$$

$$\sigma_{CR} = 1/2 \left\{ (\sigma_{ex} + \sigma_{ey} + \bar{Q}_a) - \left[ (\sigma_{ex} + \sigma_{ey} + \bar{Q}_a)^2 - 4(\sigma_{ex}\sigma_{ey} + \sigma_{ex}\bar{Q}_a - \sigma_{exy}^2) \right]^{1/2} \right\} \quad (\text{Eq. D4.1-5})$$

(3) I-Sections (doubly-symmetric)

$$\sigma_{CR} = \sigma_{ey} + \bar{Q}_a \quad (\text{Eq. D4.1-6})$$

$$\sigma_{CR} = \sigma_{ex} \quad (\text{Eq. D4.1-7})$$

In the above formulas

$$\sigma_{ex} = \pi^2 E / (K_x L_x / r_x)^2 \quad (\text{Eq. D4.1-8})$$

$$\sigma_{exy} = (\pi^2 E I_{xy}) / (AL^2) \quad (\text{Eq. D4.1-9})$$

$$\sigma_{ey} = \pi^2 E / (K_y L_y / r_y)^2 \quad (\text{Eq. D4.1-10})$$

$$\sigma_t = 1 / (Ar_0^2) [GJ + \pi^2 EC_w / (K_t L_t)^2] \quad (\text{Eq. D4.1-11})$$

$$\sigma_{tQ} = \sigma_t + \bar{Q}_t \quad (\text{Eq. D4.1-12})$$

$\bar{Q} = \bar{q}B =$  Design shear rigidity for sheathing on both sides of the wall assembly (Eq. D4.1-12)

$\bar{q} =$  Design shear rigidity for sheathing per inch of stud spacing

(see Table D4)

B = Stud spacing

$$\bar{Q}_a = \bar{Q} / A \quad (\text{Eq. D4.1-13})$$

A = Area of full unreduced cross section

L = Length of stud

$$\bar{Q}_t = (\bar{Q}d^2) / (4Ar_0^2) \quad (\text{Eq. D4.1-14})$$

d = Depth of section

$I_{xy}$  = Product of inertia

- (c) To prevent shear failure of the sheathing, a value of  $F_n$  shall be used in the following equations so that the shear strain of the sheathing,  $\gamma$ , does not exceed the permissible shear strain,  $\bar{\gamma}$ .

The shear strain,  $\gamma$ , shall be determined as follows:

$$\gamma = (\pi/L)[C_1 + (E_1 d/2)] \quad (\text{Eq. D4.1-15})$$

where

$C_1$  and  $E_1$  are the absolute values of  $C_1$  and  $E_1$  specified below for each section type:

- (1) Singly-Symmetric Channels

$$C_1 = (F_n C_o) / (\sigma_{ey} - F_n + \bar{Q}_a) \quad (\text{Eq. D4.1-16})$$

$$E_1 = \frac{F_n [(\sigma_{ex} - F_n)(r_o^2 E_o - x_o D_o) - F_n x_o (D_o - x_o E_o)]}{(\sigma_{ex} - F_n) r_o^2 (\sigma_{tQ} - F_n) - (F_n x_o)^2} \quad (\text{Eq. D4.1-17})$$

- (2) Z-Sections

$$C_1 = \frac{F_n [C_o (\sigma_{ex} - F_n) - D_o \sigma_{exy}]}{(\sigma_{ey} - F_n + \bar{Q}_a)(\sigma_{ex} - F_n) - \sigma_{exy}^2} \quad (\text{Eq. D4.1-18})$$

$$E_1 = (F_n E_o) / (\sigma_{tQ} - F_n) \quad (\text{Eq. D4.1-19})$$

- (3) I-Sections

$$C_1 = (F_n C_o) / (\sigma_{ey} - F_n + \bar{Q}_a) \quad (\text{Eq. D4.1-20})$$

$$E_1 = 0$$

where

$x_o$  = distance from shear center to centroid along principal x-axis,  
in. (absolute value)

$C_o$ ,  $E_o$ , and  $D_o$  are initial column imperfections which shall be assumed to be at least

$$C_o = L/350 \text{ in a direction parallel to the wall} \quad (\text{Eq. D4.1-21})$$

$$D_o = L/700 \text{ in a direction perpendicular to the wall} \quad (\text{Eq. D4.1-22})$$

$E_o = L/(dx10,000)$ , rad., a measure of the initial twist of the stud from the initial, ideal, unbuckled shape. (Eq. D4.1-23)

If  $F_n > 0.5F_y$ , then in the definitions for  $\sigma_{ey}$ ,  $\sigma_{ex}$ ,  $\sigma_{exy}$  and  $\sigma_{tQ}$ , the parameters E and G shall be replaced by E' and G', respectively, as defined below

$$E' = 4EF_n(F_y - F_n)/F_y^2 \quad (\text{Eq. D4.1-24})$$

$$G' = G(E'/E) \quad (\text{Eq. D4.1-25})$$

Sheathing parameters  $\bar{q}_o$  and  $\bar{v}$  may be determined from representative full-scale tests, conducted and evaluated as described by published documented methods (see Commentary), or from the small-scale-test values given in Table D4.

TABLE D4  
Sheathing Parameters<sup>(1)</sup>

Sheathing <sup>(2)</sup>	$\bar{q}_o$ (3) k/in.	$\bar{v}$ in./in.
3/8 to 5/8 in. thick gypsum	2.0	0.008
Lignocellulosic board	1.0	0.009
Fiberboard (regular or impregnated)	0.6	0.007
Fiberboard (heavy impregnated)	1.2	0.010

(1) The values given are subject to the following limitations:

All values are for sheathing on both sides of the wall assembly.

All fasteners are No. 6, type S-12, self-drilling drywall screws with pan or bugle head, or equivalent, at 6-to 12-inch spacing.

(2) All sheathing is 1/2-inch thick except as noted.

(3)  $\bar{q} = \bar{q}_o(2-s/12)$  (Eq. D4.1-26)

where s = fastener spacing, in.

For other types of sheathing,  $q_o$  and  $\gamma$  may be determined conservatively from representative small-specimen tests as described by published documented methods (see Commentary).

#### D4.2 Wall Studs in Bending

For studs having identical sheathing attached to both flanges, and neglecting any rotational restraint provided by the sheathing<sup>\*</sup>, the design flexural strengths are  $\phi_b M_{nxo}$  and  $\phi_b M_{nyo}$  as follows:

where

$\phi_b = 0.95$  for sections with stiffened or partially stiffened  
compression flanges

$= 0.90$  for sections with unstiffened compression flanges

$M_{nxo}$  and  $M_{nyo}$  = Nominal flexural strengths about the centroidal axes  
determined in accordance with Section C3.1, excluding  
the provisions of Section C3.1.2 (lateral buckling)

#### D4.3 Wall Studs with Combined Axial Load and Bending

The required axial strength and flexural strengths shall satisfy the interaction equations of Section C5 with the following redefined terms:

$P_n$  = Nominal axial strength determined according to Section D4.1

$M_{nx}$  and  $M_{ny}$  in Equations C5-1, C5-2, and C5-3 shall be replaced by  
nominal flexural strengths,  $M_{nxo}$  and  $M_{nyo}$ , respectively.

---

\*Studs with sheathing on one flange only, or with unidentical sheathing on both flanges, or having rotational restraint that is not neglected, or having any combination of the above, shall be designed in accordance with the same basic analysis principles used in deriving the provisions of this Section.

## E. CONNECTIONS AND JOINTS

### E1 General Provisions

Connections shall be designed to transmit the maximum forces resulting from the factored loads acting on the connected member. Proper regard shall be given to eccentricity.

### E2 Welded Connections

The following LRFD design criteria govern welded connections used for cold-formed steel structural members in which the thickness of the thinnest connected part is 0.18 in. or less. For welded connections in which the thickness of the thinnest connected part is greater than 0.18 in., refer to the AISC's "Load and Resistance Factor Design Specification for Structural Steel Buildings," September 1, 1986.

Except as modified herein, arc welds on steel where at least one of the connected parts is 0.18 inch or less in thickness shall be made in accordance with AWS D-1.3 (Reference 4 of Section A6) and its Commentary. Welders and welding procedures shall be qualified as specified in AWS D1.3. These provisions are intended to cover the welding positions as shown in Table E2.

The required strength on each weld shall not exceed the design strength,

$$\phi P_n,$$

where

$\phi$  = Resistance factor for arc welded connections defined in Sections E2.1 through E2.5.

$P_n$  = Nominal strength of welds determined according to Sections E2.1 through E2.5.



The design strengths,  $\phi P_n$ , for resistance welds made in conformance with the procedures given in AWS C1.1-66, "Recommended Practices for Resistance Welding" or AWS C1.3-70, "Recommended Practice for Resistance Welding Coated Low Carbon Steels" are given in Section E2.6.

TABLE E2

Connection	Welding Position					
	Square Groove Butt Weld	Arc Spot Weld	Arc Seam Weld	Fillet Weld, Lap or T	Flare-Bevel Groove	Flare-V Groove Weld
Sheet to Sheet	F	-	F	F	F	F
	H	-	H	H	H	H
	V	-	-	V	V	V
	OH	-	-	OH	OH	OH
Sheet to Supporting Member	-	F	F	F	F	-
	-	-	-	H	H	-
	-	-	-	V	V	-
	-	-	-	OH	OH	-

(F = flat, H = horizontal, V = vertical, OH = overhead)

#### E2.1 Groove Welds in Butt Joints

The design strength,  $\phi P_n$ , of a groove weld in a butt joint, welded from one or both sides, shall be determined as follows:

- (a) Tension or compression normal to the effective area or parallel to the axis of the weld

$$\phi = 0.90$$

$$P_n = Lt_e F_y \quad (\text{Eq. E2.1-1})$$

(b) Shear on the effective area

$$\phi = 0.80$$

$$P_n = Lt_e (0.6F_{xx}); \text{ and} \quad (\text{Eq. E2.1-2})$$

$$\phi = 0.90$$

$$P_n = Lt_e (F_y / \sqrt{3}) \quad (\text{Eq. E2.1-3})$$

where

$\phi$  = Resistance factor for welded connections

$P_n$  = Nominal strength of a groove weld

$F_{xx}$  = Strength level designation in AWS electrode classification

$F_y$  = Specified minimum yield point of the lower strength base steel

$L$  = Length of weld

$t_e$  = Effective throat dimension for groove weld

## E2.2 Arc Spot Welds

Arc spot welds permitted by this Specification are for welding sheet steel to thicker supporting members in the flat position. Arc spot welds (puddle welds) shall not be made on steel where the thinnest connected part is over 0.15 inch thick, nor through a combination of steel sheets having a total thickness over 0.15 inch.

Weld washers, Figures E2.2(A) and E2.2(B), shall be used when the thickness of the sheet is less than 0.028 inch. Weld washers shall have a thickness between 0.05 and 0.08 inch with a minimum prepunched hole of 3/8-inch diameter.

Arc spot welds shall be specified by minimum effective diameter of fused area,  $d_e$ . Minimum allowable effective diameter is 3/8 inch.

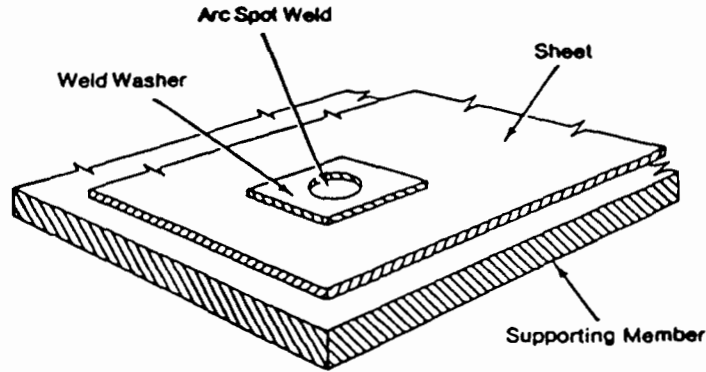

Figure E2.2A Typical Weld Washer

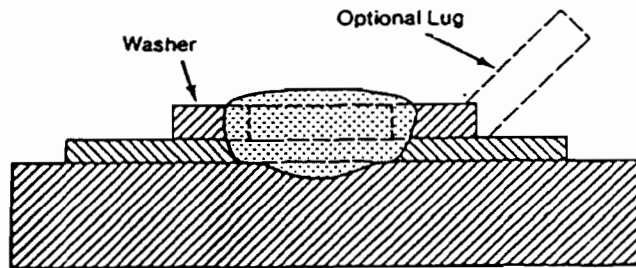

Figure E2.2B Arc Spot Weld Using Washer

The design shear strength,  $\phi P_n$ , of each arc spot weld between sheet or sheets and supporting member shall be determined by using the smaller of either

(a)  $\phi = 0.60$

$$P_n = 0.589d_e^2 F_{xx}; \text{ or} \quad (\text{Eq. E2.2-1})$$

(b) For  $(d_a/t) \leq 0.815\sqrt{(E/F_u)}$ :

$\phi = 0.60$

$$P_n = 2.20td_a F_u \quad (\text{Eq. E2.2-2})$$

For  $0.815\sqrt{(E/F_u)} < (d_a/t) < 1.397\sqrt{(E/F_u)}$ :

$\phi = 0.50$

$$P_n = 0.280[1+5.59\sqrt{E/F_u}/(d_a/t)]td_a F_u \quad (\text{Eq. E2.2-3})$$

For  $(d_a/t) \geq 1.397\sqrt{(E/F_u)}$ :

$$\phi = 0.50$$

$$P_n = 1.40td_a F_u \quad (\text{Eq. E2.2-4})$$

where

$\phi$  = Resistance factor for welded connections

$P_n$  = Nominal shear strength of an arc spot weld

$d$  = Visible diameter of outer surface of arc spot weld

$d_a$  = Average diameter of the arc spot weld at mid-thickness of  $t$

[where  $d_a = (d-t)$  for a single sheet, and  $(d-2t)$  for multiple sheets (not more than four lapped sheets over a supporting member)]

$d_e$  = Effective diameter of fused area

$$d_e = 0.7d - 1.5t \text{ but } \leq 0.55d \quad (\text{Eq. E2.2-5})$$

$t$  = Total combined base steel thickness (exclusive of coatings) of sheets involved in shear transfer

$F_{xx}$  = Stress level designation in AWS electrode classification

$F_u$  = Tensile strength as specified in Section A3.1 or A3.2 or as reduced for low-ductility steel

Note: See Figures E2.2(C) and E2.2(D) for diameter definitions.

The distance measured in the line of force from the centerline of a weld to the nearest edge of an adjacent weld or to the end of the connected part toward which the force is directed shall not be less than the value of  $e_{\min}$  as given below:

$$e_{\min} = P_u / (\phi F_u t) \quad (\text{Eq. E2.2-6})$$

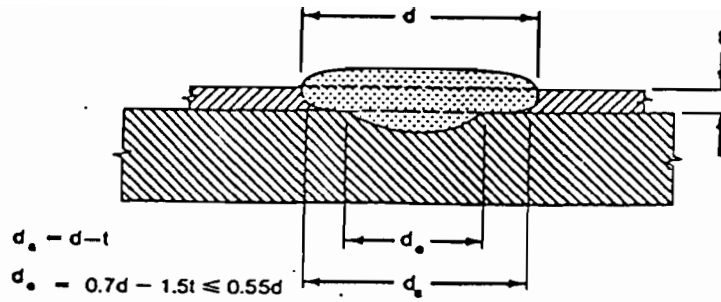

(C) Arc Spot Weld—Single Thickness of Sheet

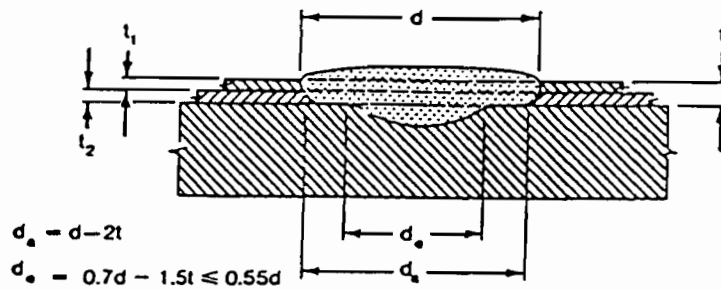

(D) Arc Spot Weld—Double Thickness of Sheet

Figure E2.2C,D Arc Spot Welds

where

$\phi$  = Resistance factor for welded connections

= 0.70 when  $F_u/F_{sy} \geq 1.15$

= 0.60 when  $F_u/F_{sy} < 1.15$

$P_u$  = Required strength transmitted by weld

$t$  = Thickness of thinnest connected sheet

$F_{sy}$  = Yield point as specified in Sections A3.1 or A3.2

Note: See Figures E2.2(E) and E2.2(F) for edge distance of arc welds.

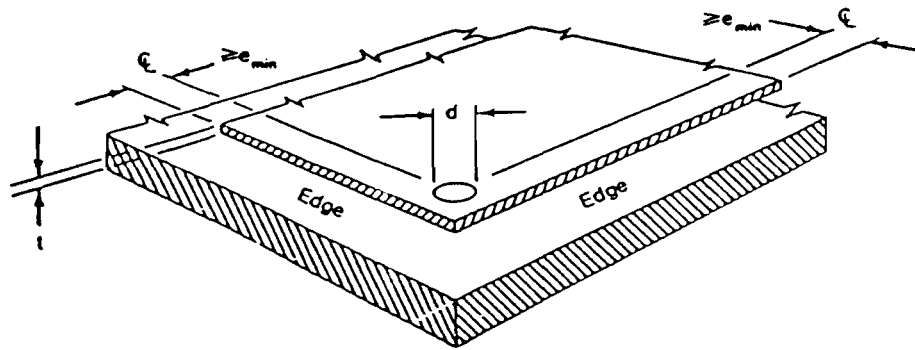

(E) Single Sheet

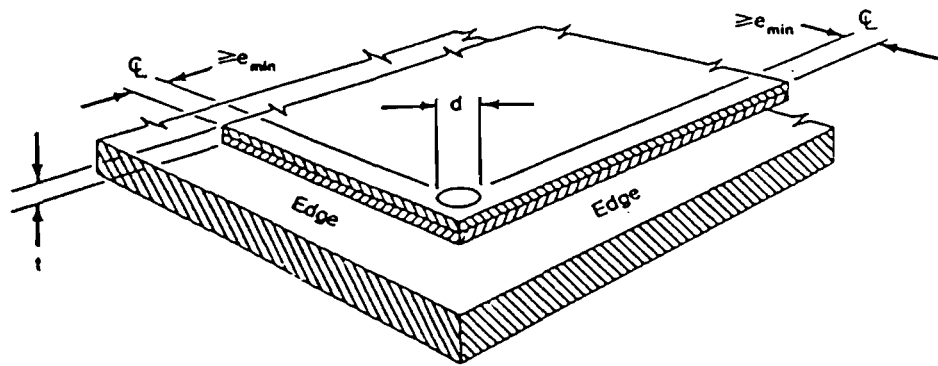

(F) Double Sheet

Figure E2.2E,F Edge Distances for Arc Spot Welds

In addition, the distance from the centerline of any weld to the end or boundary of the connected member shall not be less than  $1.5d$ . In no case shall the clear distance between welds and the end of member be less than  $1.0d$ .

If it can be shown by measurement that a given weld procedure will consistently give a larger effective diameter,  $d_e$ , or average diameter,  $d_a$ , as applicable, this larger diameter may be used providing the particular welding procedure used for making those welds is followed.

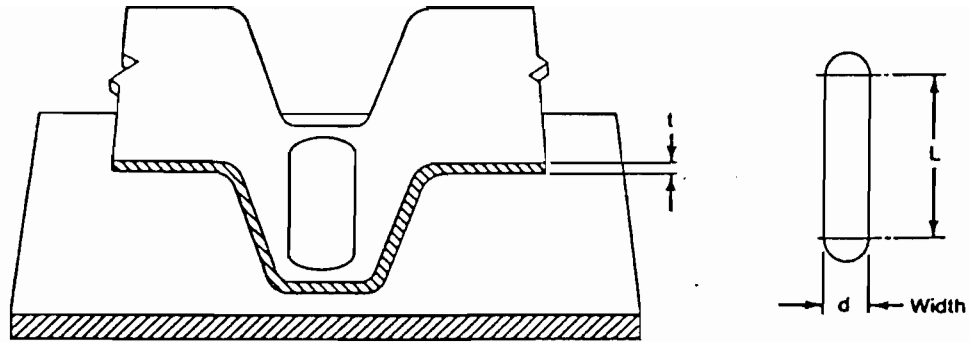

Figure E2.3A Arc Seam Welds - Sheet to Supporting Member in Flat Position

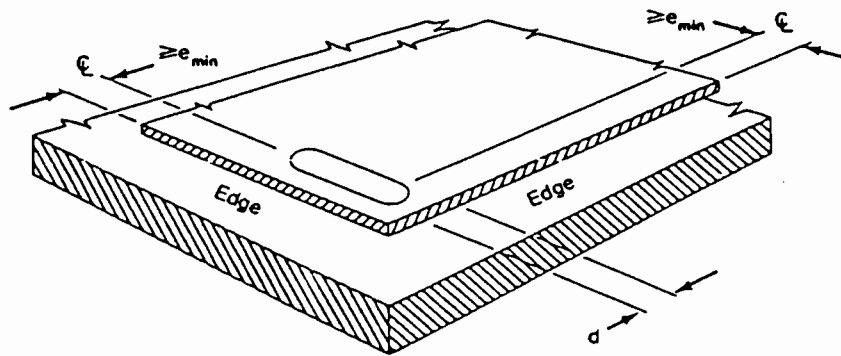

Figure E2.3B Edge Distances for Arc Seam Welds

### E2.3 Arc Seam Welds

Arc seam welds [Figure E2.3(A)] covered by this Specification apply only to the following joints:

- (a) Sheet to thicker supporting member in the flat position.
- (b) Sheet to sheet in the horizontal or flat position.

The design shear strength,  $\phi P_n$ , of arc seam welds shall be determined by using the smaller of either

(a)  $\phi = 0.60$

$$P_n = (\pi d_e^2/4 + L d_e)(0.75 F_{xx}); \text{ or} \quad (\text{Eq. E2.3-1})$$

(b)  $\phi = 0.60$

$$P_n = 2.5tF_u(0.25L+0.96d_a) \quad (\text{Eq. E2.3-2})$$

where

$\phi$  = Resistance factor for welded connections

$P_n$  = Nominal shear strength of an arc seam weld

$d$  = Width of arc seam weld

$L$  = Length of seam weld not including the circular ends (For computation purposes,  $L$  shall not exceed  $3d$ )

$d_a$  = Average width of seam weld

where

$$d_a = (d-t) \text{ for a single sheet, and} \quad (\text{Eq. E2.3-3})$$

$$(d-2t) \text{ for a double sheet} \quad (\text{Eq. E2.3-4})$$

$d_e$  = Effective width of arc seam weld at fused surfaces

$$d_e = 0.7d-1.5t \quad (\text{Eq. E2.3-5})$$

and  $F_u$  and  $F_{xx}$  are defined in Section E2.2. The minimum edge distance shall be as determined in Section E2.2 for the arc spot weld. See Figure E2.3(B).

#### E2.4 Fillet Welds

Fillet welds covered by this Specification apply to the welding of joints in any position, either

- (a) Sheet to sheet, or
- (b) Sheet to thicker steel member.

The design shear strength,  $\phi P_n$ , of a fillet weld shall be determined as follows:

- (a) For longitudinal loading:

For  $L/t < 25$ :

$$\phi = 0.60$$



$$P_n = (1 - 0.01L/t)tLF_u \quad (\text{Eq. E2.4-1})$$

For  $L/t \geq 25$ :

$$\phi = 0.55$$

$$P_n = 0.75tLF_u \quad (\text{Eq. E2.4-2})$$

(b) For transverse loading:

$$\phi = 0.60$$

$$P_n = tLF_u \quad (\text{Eq. E2.4-3})$$

where  $t$  = Least value of  $t_1$  or  $t_2$  (see Figure E2.4)

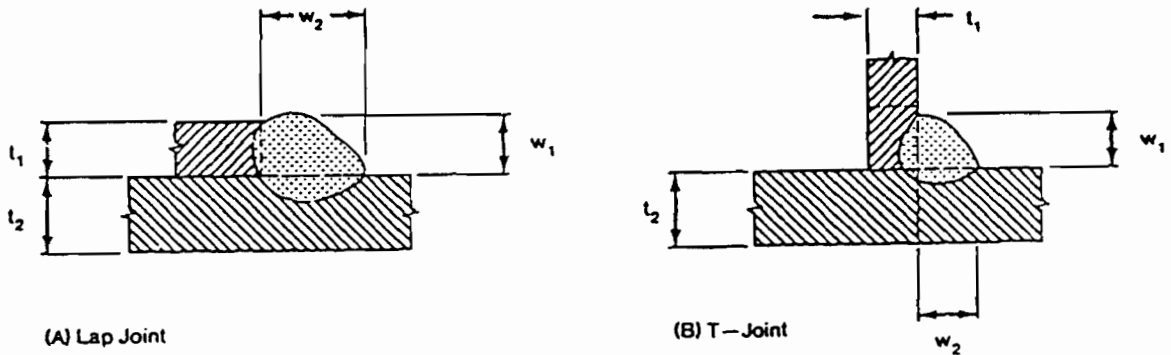

Figure E2.4 Fillet Welds

In addition, for  $t > 0.150$  inch the design strength determined above shall not exceed the following value of  $\phi P_n$ :

$$\phi = 0.60$$

$$P_n = 0.75t_w LF_{xx} \quad (\text{Eq. E2.4-4})$$

where

$\phi$  = Resistance factor for welded connections

$P_n$  = Nominal strength of a fillet weld

$L$  = Length of fillet weld

$t_w$  = Effective throat =  $0.707w_1$  or  $0.707w_2$ , whichever is smaller.

A larger effective throat may be taken if it can be shown by measurement that a given welding procedure will consistently give a larger value providing the particular welding procedure used for making the welds that are measured is followed.

$w_1$  and  $w_2$  = leg on weld (See Figure E2.4)

$F_u$  and  $F_{xx}$  are defined in Section E2.2.

#### E2.5 Flare Groove Welds

Flare groove welds covered by this Specification apply to welding of joints in any position, either:

- (a) Sheet to sheet for flare-V groove welds, or
- (b) Sheet to sheet for flare-bevel groove welds, or
- (c) Sheet to thicker steel member for flare-bevel groove welds.

The design shear strength,  $\phi P_n$ , of a flare groove weld shall be determined as follows:

- (a) For flare-bevel groove welds, transverse loading (See Figure E2.5(A)):

$$\phi = 0.55$$

$$P_n = 0.833tLF_u \quad (\text{Eq. E2.5-1})$$

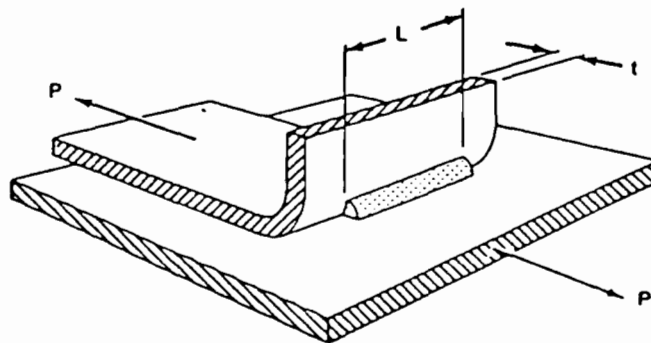

Figure E2.5A Flare-Bevel Groove Weld

(b) For flare groove welds, longitudinal loading (See Figures E2.5(B), E2.5(C), and E2.5(D)):

(1) For  $t \leq t_w < 2t$  or if the lip height is less than weld length,  $L$ :

$$\phi = 0.55$$

$$P_n = 0.75tLF_u \quad (\text{Eq. E2.5-2})$$

(2) For  $t_w \geq 2t$  and the lip height is equal to or greater than  $L$ :

$$\phi = 0.55$$

$$P_n = 1.50tLF_u \quad (\text{Eq. E2.5-3})$$

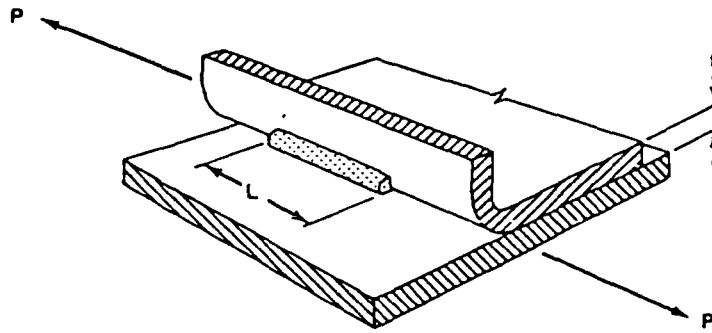

(B) Flare Bevel Groove

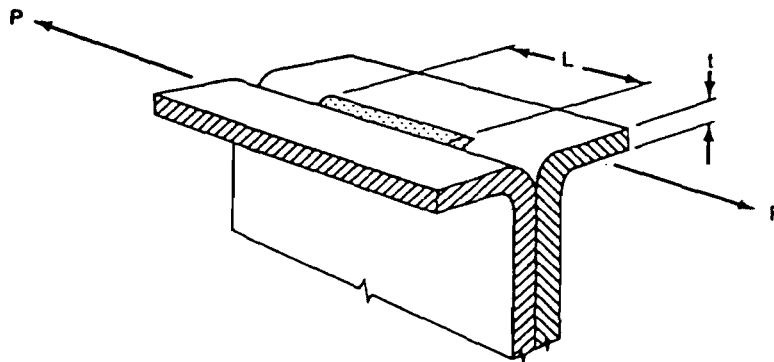

(C) Flare V-Groove

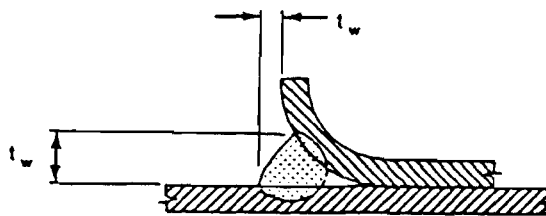

(D) Throat

Figure E2.5B,C,D Shear in Flare Groove Welds

In addition, if  $t > 0.15$  inch, the design strength determined above shall not exceed the following value of  $\phi P_n$ :

$$\phi = 0.60$$

$$P_n = 0.75 t_w L F_{xx} \quad (\text{Eq. E2.5-4})$$

### E2.6 Resistance Welds

The design shear strength,  $\phi P_n$ , of spot welding shall be determined as follows:

$$\phi = 0.65$$

$$P_n = \text{Tabulated value given in Table E2.6}$$

TABLE E2.6

Nominal Shear Strength of Spot Welding

Thickness of Thinnest Outside Sheet, in.	Shear Strength per spot kips	Thickness of Thinnest Outside Sheet, in.	Shear Strength per spot kips
0.010	0.125	0.080	3.325
0.020	0.438	0.094	4.313
0.030	1.000	0.109	5.988
0.040	1.425	0.125	7.200
0.050	1.650	0.188	10.000
0.060	2.275	0.250	15.000

### E3 Bolted Connections

The following LRFD design criteria govern bolted connections used for cold-formed steel structural members in which the thickness of the thinnest connected part is less than 3/16 inch. For bolted connections in which the thickness of the thinnest connected part is equal to or greater than 3/16 inch, refer to AISC's "Load and Resistance Factor Design Specification for Structural Steel Buildings," September 1, 1986.

Bolts, nuts, and washers shall generally conform to one of the following specifications:

ASTM A307-84 (Type A), Carbon Steel Externally and Internally Threaded Standard Fasteners

ASTM A325-84, High Strength Bolts for Structural Steel Joints

ASTM A354-84 (Grade BD), Quenched and Tempered Alloy Steel Bolts, Studs, and Other Externally Threaded Fasteners (for diameter of bolt smaller than 1/2 inch)

ASTM A449-84a, Quenched and Tempered Steel Bolts and Studs (for diameter of bolt smaller than 1/2 inch)

ASTM A490-84, Quenched and Tempered Alloy Steel Bolts for Structural Steel Joints

ASTM A563-84, Carbon and Alloy Steel Nuts

ASTM F436-86, Hardened Steel Washers.

When other than the above are used, drawings shall indicate clearly the type and size of fasteners to be employed and the nominal strength assumed in design.

Bolts shall be installed and tightened to achieve satisfactory performance of the connections involved under usual service conditions.

The holes for bolts shall not exceed the sizes specified in Table E3, except that larger holes may be used in column base details or structural systems connected to concrete walls.

TABLE E3  
Maximum Size of Bolt Holes, Inches

Nominal Bolt Diameter, d in.	Standard Hole Diameter, d <sub>h</sub> in.	Oversized Hole Diameter, d <sub>h</sub> in.	Short-Slotted Hole Dimensions in.	Long-Slotted Hole Dimensions in.
< 1/2	d+1/32	d+1/16	(d+1/32)by(d+1/4)	(d+1/32)by(2-1/2d)
≥ 1/2	d+1/16	d+1/8	(d+1/16)by(d+1/4)	(d+1/16)by(2-1/2d)

Standard holes shall be used in bolted connections, except that oversized and slotted holes may be used as approved by the designer. The length of slotted holes shall be normal to the direction of the shear load. Washers or backup plates shall be installed over oversized or short-slotted holes in an outer ply unless suitable performance is demonstrated by load tests in accordance with Section F.

#### E3.1 Spacing and Edge Distance

The design shear strength,  $\phi P_n$ , of the connected part along two parallel lines in the direction of applied force shall be determined as follows:

$$P_n = teF_u \quad (\text{Eq. E3.1-1})$$

(a) When  $F_u/F_{sy} \geq 1.15$ :

$$\phi = 0.70$$

(b) When  $F_u/F_{sy} < 1.15$ :

$$\phi = 0.60$$

where

$\phi$  = Resistance factor

$P_n$  = Nominal resistance per bolt

$e$  = The distance measured in the line of force from the center of a standard hole to the nearest edge of an adjacent hole or to the end of the connected part

$t$  = Thickness of thinnest connected part

$F_u$  = Tensile strength of the connected part as specified in Sections A3.1 or A3.2

$F_{sy}$  = Yield point of the connected part as specified in Sections A3.1 or A3.2

In addition, the minimum distance between centers of bolt holes shall provide sufficient clearance for bolt heads, nuts, washers and the wrench but shall not be less than 3 times the nominal bolt diameter,  $d$ . Also, the distance from the center of any standard hole to the end or other boundary of the connecting member shall not be less than 1-1/2  $d$ .

For oversized and slotted holes, the distance between edges of two adjacent holes and the distance measured from the edge of the hole to the end or other boundary of the connecting member in the line of stress shall not be less than the value of  $[e - (d_h/2)]$ , in which  $e$  is the required distance computed from the applicable equation given above, and  $d_h$  is the diameter of a standard hole defined in Table E3. In no case shall the clear distance between edges of two adjacent holes be less than  $2d$  and the distance between the edge of the hole and the end of the member be less than  $d$ .

### E3.2 Tension in Connected Part

The design tensile strength,  $\phi P_n$ , on the net section of the connected part shall be determined as follows:

(a) Washers are provided under both the bolt head and the nut

$$P_n = (1.0 - 0.9r + 3rd/s)F_u A_n \leq F_u A_n \quad (\text{Eq. E3.2-1})$$

$$\phi = 0.65 \text{ for double shear connection}$$

$$\phi = 0.55 \text{ for single shear connection}$$

(b) Either washers are not provided under the bolt head and nut, or only one washer is provided under either the bolt head or nut

$$\phi = 0.65$$

$$P_n = (1.0 - r + 2.5rd/s)F_u A_n \leq F_u A_n \quad (\text{Eq. E3.2-2})$$

In addition, the design tensile strength shall not exceed the following values:

$$\phi = 0.95$$

$$P_n = F_y A_n \quad (\text{Eq. E3.2-3})$$

where

$A_n$  = Net area of the connected part

$r$  = Force transmitted by the bolt or bolts at the section considered, divided by the tension force in the member at that section. If  $r$  is less than 0.2, it may be taken equal to zero.

$s$  = Spacing of bolts perpendicular to line of stress. In the case of a single bolt,  $s$  = Width of sheet

$F_u$  = Tensile strength of the connected part as specified in Sections A3.1 or A3.2

$F_y$  = Yield point of the connected part

$d$  and  $t$  are defined in Section E3.1



### E3.3 Bearing

The design bearing strength,  $\phi P_n$ , shall be determined by the values of  $\phi$  and  $P_n$  given in Tables E3.3-1 and E3.3-2 for the applicable thickness and  $F_u/F_{sy}$  ratio of the connected part and the type of joint used in the connection.

In Tables E3.3-1 and E3.3-2, the symbols  $\phi$ ,  $P_n$ ,  $d$ ,  $F_u$  and  $t$  were previously defined. For conditions not shown, the design bearing strength of bolted connections shall be determined by tests.

TABLE E3.3-1  
Nominal Bearing Strength for Bolted Connections  
with Washers Under Both Bolt Head and Nut

Thickness of Connected Part in.	Type of Joint	$F_u/F_{sy}$ ratio of Connected Part	Resistance Factor $\phi$	Nominal Resistance $P_n$
$\geq 0.024$ but $< 3/16$	Inside sheet of double shear connection	$\geq 1.15$	0.55	$3.33F_u dt$
		$< 1.15$	0.65	$3.00F_u dt$
	Single shear and outside sheets of double shear connection	No limit	0.60	$3.00F_u dt$
$\geq 3/16$	See AISC LRFD Specification			

TABLE E3.3-2  
Nominal Bearing Strength for Bolted Connections  
Without Washers Under Both Bolt Head and Nut,  
or With Only One Washer

Thickness of Connected Part in.	Type of Joint	$F_u/F_{sy}$ ratio of Connected Part	Resistance Factor $\phi$	Nominal Resistance $P_n$
$\geq 0.036$ but $< 3/16$	Inside sheet of double shear connection	$\geq 1.15$	0.70	$3.00F_u dt$
	Single shear and outside sheets of double shear connection	$\geq 1.15$	0.65	$2.22F_u dt$
$\geq 3/16$	See AISC LRFD Specification			

#### E3.4 Shear and Tension in Bolts

The required bolt strength in shear or tension shall not exceed the design strength,  $\phi P_n$ , determined as follows:

$\phi$  = Resistance factor given in Table E3.4-1

$$P_n = A_b F_n \quad (\text{Eq. E3.4-1})$$

where

$A_b$  = Gross cross-sectional area of bolt

$F_n$  is given by  $F_{nv}$  or  $F_{nt}$  in Table E3.4-1.

The pullover strength of the connected sheet at the bolt head, nut or washer should be considered where bolt tension is involved, see Section E5.2.

TABLE E3.4-1  
Nominal Tensile and Shear Strengths for Bolts

Description of Bolts	Tensile Strength		Shear Strength*	
	Resistance Factor $\phi$	Nominal Stress $F_{nt}$	Resistance Factor $\phi$	Nominal Stress $F_{nv}$
A307 Bolts, Grade A (1/4 in. $\leq d < 1/2$ in.)	0.75	40.5	0.65	24.0
A307 Bolts, Grade A ( $d \geq 1/2$ in.)		45.0		27.0
A325 bolts, when threads are not excluded from shear planes		90.0		54.0
A325 bolts, when threads are excluded from shear planes		90.0		72.0
A354 Grade B Bolts (1/4 in. $\leq d < 1/2$ in.), when threads are not excluded from shear planes		101.0		59.0
A354 Grade B Bolts (1/4 in. $\leq d < 1/2$ in.), when threads are excluded from shear planes		101.0		90.0
A449 Bolts (1/4 in. $\leq d < 1/2$ in.), when threads are not excluded from shear planes		81.0		47.0
A449 Bolts (1/4 in. $\leq d < 1/2$ in.), when threads are excluded from shear planes		81.0		72.0
A490 Bolts, when threads are not excluded from shear planes		112.5		67.5
A490 Bolts, when threads are excluded from shear planes		112.5		90.0

\*Applies to bolts in holes as limited by Table E3. Washers or back-up plates shall be installed over long-slotted holes and the capacity of connections using long-slotted holes shall be determined by load tests in accordance with Section F.

When bolts are subject to a combination of shear and tension produced by factored loads, the required tension strength shall not exceed the design strength,  $\phi P_n$ , based on  $\phi = 0.75$  and  $P_n = A_b F'_{nt}$ , where  $F'_{nt}$  is given in Table E3.4-2, in which  $f_v$  is the shear stress produced by the same factored loads. The required shear strength shall not exceed the design shear strength,  $\phi A_b F_{nv}$ , determined in accordance with Table E3.4-1.

TABLE E3.4-2

Nominal Tension Stress,  $F'_{nt}$ , for Bolts

Subject to the Combination of Shear and Tension

Description of Bolts	Threads Not Excluded from Shear Planes	Threads Excluded from Shear Planes
A325 Bolts	$113 - 2.4f_v \leq 90$	$113 - 1.9f_v \leq 90$
A354 Grade BD Bolts	$127 - 2.4f_v \leq 101$	$127 - 1.9f_v \leq 101$
A449 Bolts	$101 - 2.4f_v \leq 81$	$101 - 1.9f_v \leq 81$
A490 Bolts	$141 - 2.4f_v \leq 112.5$	$141 - 1.9f_v \leq 112.5$
A307 Bolts, Grade A when $1/4 \text{ in.} \leq d < 1/2$ in. when $d \geq 1/2 \text{ in.}$	$47 - 2.4f_v \leq 40.5$  $52 - 2.4f_v \leq 45$	

At beam-end connections, where one or more flanges are coped and failure might occur along a plane through the fasteners, the required shear strength shall not exceed the design shear strength  $\phi V_n$ .

where

$$\phi = 0.75$$

$$V_n = 0.6F_u A_{wn} \quad (\text{Eq. E4-1})$$

$$A_{wn} = (d_{wc} - nd_h)t \quad (\text{Eq. E4-2})$$

$d_{wc}$  = Coped web depth

$n$  = Number of holes in the critical plane

$d_h$  = Hole diameter

$F_u$  = Tensile strength as specified in Sections A3.1 or A3.2

$t$  = Thickness of coped web

## E5 Connections to Other Materials

### E5.1 Bearing

Proper provisions shall be made to transfer bearing forces resulting from axial loads and moments from steel components covered by the Specification to adjacent structural components made of other materials. The required bearing strength in the contact area shall not exceed the design strength,  $\phi_c P_p$ .

In the absence of code regulations, the design bearing strength on concrete may be taken as  $\phi_c P_p$ :

On the full area of a concrete support-----  $P_p = 0.85f'_c A_1$

On less than the full area of a concrete

support-----  $P_p = 0.85f'_c A_1 \sqrt{A_2/A_1}$

where

$$\phi_c = 0.60$$

$f'_c$  = Specified compression strength of concrete

$A_1$  = Bearing area

$A_2$  = Full cross-sectional area of concrete support

The value of  $\sqrt{A_2/A_1}$  shall not exceed 2.

### E5.2 Tension

The pull-over shear/tension forces in the steel sheet around the head of the fastener should be considered as well as the pull-out force resulting from factored axial loads and bending moments transmitted onto the fastener from various adjacent structural components in the assembly.

The nominal tensile strength of the fastener and the nominal imbedment strength of the adjacent structural component shall be determined by applicable product code approvals, or product specifications and/or product literature.

### E5.3 Shear

Proper provisions shall be made to transfer shearing forces from steel components covered by this Specification to adjacent structural components made of other materials. The required shear and/or bearing strength on the steel components shall not exceed that allowed by this Specification. The design shear strength on the fasteners and other material shall not be exceeded. Imbedment requirements are to be met. Proper provision shall also be made for shearing forces in combination with other forces.

## F. TESTS FOR SPECIAL CASES

- (a) Tests shall be made by an independent testing laboratory or by a testing laboratory of a manufacturer.
- (b) The provisions of Chapter F do not apply to cold-formed steel diaphragms.

### F1 Tests for Determining Structural Performance

Where the composition or configuration of elements, assemblies, connections, or details of cold-formed steel structural members are such that calculation of their load-carrying capacity or deflection cannot be made in accordance with the provisions of this Specification, their structural performance shall be established from tests and evaluated in accordance with the following procedure.

- (a) Where practicable, evaluation of the test results shall be made on the basis of the average value of test data resulting from tests of not fewer than four identical specimens, provided the deviation of any individual test result from the average value obtained from all tests does not exceed  $\pm 10$  percent. If such deviation from the average value exceeds 10 percent, at least three more tests of the same kind shall be made. The average value of all tests made shall then be regarded as the predicted capacity,  $R_p$ , for the series of the tests. The mean value and the coefficient of variation of the tested-to-predicted load ratios for all tests,  $P_m$  and  $V_p$ , shall be determined for statistical analysis.
- (b) The load-carrying capacity of the tested elements, assemblies, connections, or members shall satisfy Eq. F1-1.

$$\phi R_p \geq \sum \gamma_i Q_i \quad (\text{Eq. F1-1})$$

where

$\Sigma \gamma_i Q_i$  = Required resistance based on the most critical load combination determined in accordance with Section A5.1.4.  $\gamma_i$  and  $Q_i$  are load factors and load effects, respectively.

$R_p$  = Average value of all test results

$\phi$  = Resistance factor

$$= 1.5(M_m F_m P_m) \exp(-\beta_o \sqrt{V_M^2 + V_F^2 + C_P V_P^2 + V_Q^2})^* \quad (\text{Eq. F1-2})$$

$M_m$  = Mean value of the material factor listed in Table F1 for the type of component involved

$F_m$  = Mean value of the fabrication factor listed in Table F1 for the type of component involved

$P_m$  = Mean value of the tested-to-predicted load ratios determined in Section F1(a)

$\beta_o$  = Target reliability index  
= 2.5 for structural members and 3.5 for connections

$V_M$  = Coefficient of variation of the material factor listed in Table F1 for the type of component involved

$V_F$  = Coefficient of variation of the fabrication factor listed in Table F1 for the type of component involved

$C_P$  = Correction factor  
=  $(n-1)/(n-3)$  (Eq. F1-3)

$V_P$  = Coefficient of variation of the tested-to-predicted load ratios determined in Section F1(a)

---

\*For beams having tension flange through-fastened to deck or sheathing and with compression flange laterally unbraced,  $\phi$  shall be determined with a coefficient of 1.6 in lieu of 1.5,  $\beta_o = 1.5$ , and  $V_Q = 0.43$ .



Table F1  
Statistical Data for the Determination of Resistance Factor

Type of Component	$M_m$	$V_M$	$F_m$	$V_F$
Transverse Stiffeners	1.10	0.10	1.00	0.05
Shear Stiffeners	1.00	0.06	1.00	0.05
Tension Members	1.10	0.10	1.00	0.05
Flexural Members				
Bending Strength	1.10	0.10	1.00	0.05
Lateral Buckling Strength	1.00	0.06	1.00	0.05
One Flange Through-Fastened to Deck or Sheathing	1.10	0.10	1.00	0.05
Shear Strength	1.10	0.10	1.00	0.05
Combined Bending and Shear	1.10	0.10	1.00	0.05
Web Crippling Strength	1.10	0.10	1.00	0.05
Combined Bending and Web Crippling	1.10	0.10	1.00	0.05
Concentrically Loaded Compression Members	1.10	0.10	1.00	0.05
Combined Axial Load and Bending	1.05	0.10	1.00	0.05
Cylindrical Tubular Members				
Bending Strength	1.10	0.10	1.00	0.05
Axial Compression	1.10	0.10	1.00	0.05
Wall Studs and Wall Stud Assemblies				
Wall Studs in Compression	1.10	0.10	1.00	0.05
Wall Studs in Bending	1.10	0.10	1.00	0.05
Wall Studs with Combined Axial Load and Bending	1.05	0.10	1.00	0.05

Table F1 (Continued)

Statistical Data for the Determination of Resistance Factor

Type of Component	$M_m$	$V_M$	$F_m$	$V_F$
Welded Connections				
Arc Spot Welds				
Shear Strength of Welds	1.10	0.10	1.00	0.10
Plate Failure	1.10	0.08	1.00	0.15
Arc Seam Welds				
Shear Strength of Welds	1.10	0.10	1.00	0.10
Plate Tearing	1.10	0.10	1.00	0.10
Fillet Welds				
Shear Strength of Welds	1.10	0.10	1.00	0.10
Plate Failure	1.10	0.08	1.00	0.15
Flare Groove Welds				
Shear Strength of Welds	1.10	0.10	1.00	0.10
Plate Failure	1.10	0.10	1.00	0.10
Resistance Welds	1.10	0.10	1.00	0.10
Bolted Connections				
Minimum Spacing and Edge Distance	1.10	0.08	1.00	0.05
Tension Strength on Net Section	1.10	0.08	1.00	0.05
Bearing Strength	1.10	0.08	1.00	0.05

n = Number of tests

$V_Q$  = Coefficient of variation of the load effect  
= 0.21

The listing in Table F1 does not exclude the use of other documented statistical data if they are established from sufficient results on material properties and fabrication\*.

For steels not listed in Section A3.1, the values of  $M_m$  and  $V_M$  shall be determined by the statistical analysis for the materials used.

When distortions interfere with the proper functioning of the specimen in actual use, the load effects based on the critical load combination at the occurrence of the acceptable distortion shall also satisfy Eq. F1-1, except that the resistance factor  $\phi$  is taken as unity and that the load factor for dead load may be taken as 1.0.

- c) If the yield point of the steel from which the tested sections are formed is larger than the specified value, the test results shall be adjusted down to the specified minimum yield point of the steel which the manufacturer intends to use. The test results shall not be adjusted upward if the yield point of the test specimen is less than the minimum specified yield point. Similar adjustments shall be made on the basis of tensile strength instead of yield point where tensile strength is the critical factor.

Consideration must also be given to any variation or differences which may exist between the design thickness and the thickness of the specimens used in the tests.

---

\*See Reference 36 of the Commentary.

## F2 Tests for Confirming Structural Performance

For structural members, connections, and assemblies whose capacities can be computed according to this Specification or its specific references, confirmatory tests may be made to demonstrate the load-carrying capacity not less than the nominal resistance,  $R_n$ , specified in this Specification or its specific references for the type of behavior involved.

## F3 Tests for Determining Mechanical Properties

### F3.1 Full Section

Tests for determination of mechanical properties of full sections to be used in Section A5.2.2 shall be made as specified below:

- (a) Tensile testing procedures shall agree with Standard Methods and Definitions for Mechanical Testing of Steel Products, ASTM A370-77. Compressive yield point determinations shall be made by means of compression tests of short specimens of the section.
- (b) The compressive yield stress shall be taken as the smaller value of either the maximum compressive strength of the sections divided by the cross section area or the stress defined by one of the following methods:
  - (1) For sharp yielding steel, the yield point shall be determined by the autographic diagram method or by the total strain under load method.
  - (2) For gradual yielding steel, the yield point shall be determined by the strain under load method or by the 0.2 percent offset method.

When the total strain under load method is used, there shall be

evidence that the yield point so determined agrees within 5 percent with the yield point which would be determined by the 0.2 percent offset method.

- (c) Where the principal effect of the loading to which the member will be subjected in service will be to produce bending stresses, the yield point shall be determined for the flanges only. In determining such yield points, each specimen shall consist of one complete flange plus a portion of the web of such flat width ratio that the value of  $\rho$  for the specimen is unity.
- (d) For acceptance and control purposes, two full section tests shall be made from each lot of not more than 50 tons nor less than 30 tons of each section, or one test from each lot of less than 30 tons of each section. For this purpose a lot may be defined as that tonnage of one section that is formed in a single production run of material from one heat.
- (e) At the option of the manufacturer, either tension or compression tests may be used for routine acceptance and control purposes, provided the manufacturer demonstrates that such tests reliably indicate the yield point of the section when subjected to the kind of stress under which the member is to be used.

### F3.2 Flat Elements of Formed Sections

Tests for determining mechanical properties of flat elements of formed sections and representative mechanical properties of virgin steel to be used in Section A5.2.2 shall be made in accordance with the following provisions:

The yield point of flats,  $F_{yf}$ , shall be established by means of a weighted average of the yield points of standard tensile coupons taken longitudinally from the flat portions of a representative cold-formed member. The weighted average shall be the sum of the products of the average yield point for each flat portion times its cross-sectional area, divided by the total area of flats in the cross section. The exact number of such coupons will depend on the shape of the member, i.e., on the number of flats in the cross section. At least one tensile coupon shall be taken from the middle of each flat. If the actual virgin yield point exceeds the specified minimum yield point, the yield point of the flats,  $F_{yf}$ , shall be adjusted by multiplying the test values by the ratio of the specified minimum yield point to the actual virgin yield point.

### F3.3 Virgin Steel

The following provisions apply to steel produced to other than the ASTM Specifications listed in Section A3.1 when used in sections for which the increased yield point of the steel after cold forming shall be computed from the virgin steel properties according to Section A5.2.2. For acceptance and control purposes, at least four tensile specimens shall be taken from each lot as defined in Section F3.1(d) for the establishment of the representative values of the virgin tensile yield point and ultimate strength. Specimens shall be taken longitudinally from the quarter points of the width near the outer end of the coil.

PART II

COMMENTARY ON THE  
LOAD AND RESISTANCE FACTOR DESIGN SPECIFICATION  
FOR  
COLD-FORMED STEEL STRUCTURAL MEMBERS

COMMENTARY ON THE  
LOAD AND RESISTANCE FACTOR DESIGN SPECIFICATION  
FOR  
COLD-FORMED STEEL STRUCTURAL MEMBERS

INTRODUCTION

In the design of steel buildings, the "Allowable Stress Design Criteria" have long been used for the design of cold-formed steel structural members in the United States and other countries. Even though the theoretical concept of reliability analysis has been available for some time and the significance of such a concept in structural safety and design is well recognized, the probabilistic method has not yet been explicitly adopted as a basis for the American design standard for cold-formed steel structures.

Recently, the load and resistance factor design (LRFD) criteria have been developed for steel buildings using hot-rolled shapes and built-up members fabricated from steel plates. It became evident that the development of a new specification for load and resistance factor design of cold-formed steel is highly desirable because the design criteria for heavy hot-rolled steel construction cannot possibly cover the design features of thin-walled, cold-formed steel construction completely.

Since 1976, a joint project has been conducted at University of Missouri-Rolla and Washington University to develop the new design criteria for cold-formed steel structural members and connections based on the probabilistic approach.



The Load and Resistance Factor Design criteria developed on the basis of the 1986 Edition of the AISI Specification for allowable stress design are included in Sections A through F of this Specification.

This commentary contains a brief presentation of the methodology used for the development of the load and resistance factor design criteria. In addition, it provides a record of the reasoning behind, and the justification for, various provisions of the Specification. For detailed background information, reference is made to the research reports given in the bibliography.

## A. GENERAL PROVISIONS

### A1 Limits of Applicability and Terms

Section A1 of the LRFD Specification is essentially the same as Section A1 of the AISI Specification for allowable stress design. The definitions and various terms used for the LRFD criteria are the same as that used for the allowable stress design.

### A2 Non-Conforming Shapes and Constructions

Section A2 of the LRFD Specification is essentially the same as Section A2 of the AISI Specification for allowable stress design.

### A3 Material

This Section is essentially the same as Section A3 of the AISI Specification for allowable stress design.

In lieu of the tensile-to-yield strength limit of 1.08, the Specification permits the use of elongation requirements using the measurement technique as given in Ref. 1, and Part VII of the Manual. Because of limited experimental verification of the structural performance of members using materials having a tensile-to-yield strength ratio less than 1.08 (Ref. 2), the Specification limits the use of this material to purlins and girts meeting the elastic design requirements of Sections C3.1.1(a), C3.1.2, and C3.1.3. Thus, the use of such steel in other applications (compression members, tension members, other flexural members including those whose strength

is based on inelastic reserve capacity, etc.) is prohibited. However, in purlins and girts, concurrent axial loads of relatively small magnitude are acceptable providing the requirements of Section C5 are met and  $P_u / \phi_c P_n$  does not exceed 0.15.

#### A4 Loads

This Section is the same as Section A4 of the AISI Specification for allowable stress design.

With regard to ponding, design guidance can be found from Section K2 of the AISC Load and Resistance Factor Design Specification for Structural Steel Buildings (Ref. 3).

#### A5 Structural Analysis and Design

##### A5.1 Design Basis

The current method of designing cold-formed steel structural members, as presented in the 1986 AISI Specification (Ref. 4), is based on the Allowable Stress Design method. In this approach, the forces (bending moments, axial forces, shear forces) in structural members are computed by accepted methods of structural analysis for the specified working loads. These member forces or moments should not exceed the allowable values permitted by the AISI Specification. The AISI allowable load or moment is determined by dividing the nominal load or moment at a limit state by a factor of safety. Usual factors of safety inherent in the AISI Specification for the Design of Cold-Formed Steel Structural Members are 5/3 for beams and 23/12 for columns.

A limit state is the condition at which the structural usefulness of a load-carrying element or member is impaired to such an extent that it becomes unsafe for the occupants of the structure, or the element no longer performs its intended function. Typical limit states for cold-formed steel members are excessive deflection, yielding, buckling and attainment of maximum strength after local buckling (i.e., post-buckling strength). These limit states have been established through experience in practice or in the laboratory, and they have been thoroughly investigated through analytical and experimental research. The background for the establishment of the limit states is extensively documented in the Commentary on the AISI Specification (Refs. 5 and 6)(see also Refs. 7 and 8), and a continuing research effort provides further improvement in understanding them.

The factors of safety are provided to account for the uncertainties and variabilities inherent in the loads, the analysis, the limit state model, the material properties, the geometry, and the fabrication. Through experience it has been established that the present factors of safety provide satisfactory design.

The allowable stress design method employs only one factor of safety for a limit state. The use of multiple load factors provides a refinement in the design which can account for the different degrees of the uncertainties and variabilities of the design parameters. Such a design method is called Load and Resistance Factor Design, and its format is expressed by the following criterion:

$$\phi R_n \geq \sum \gamma_i Q_i \quad (\text{CA5.1-1})$$

where

$R_n$  = the nominal resistance

$\phi$  = resistance factor

$\gamma_i$  = load factors

$Q_i$  = load effects

The nominal resistance is the strength of the element or member for a given limit state, computed for nominal section properties and for minimum specified material properties according to the appropriate analytical model which defines the strength. The resistance factor  $\phi$  accounts for the uncertainties and variabilities inherent in the  $R_n$ , and it is usually less than unity. The load effects  $Q_i$  are the forces on the cross section (bending moment, axial force, shear force) determined from the specified minimum loads by structural analysis, and  $\gamma_i$  are the corresponding load factors which account for the uncertainties and variabilities of the loads. The load factors are greater than unity.

The advantages of LRFD are: (1) the uncertainties and the variabilities of different types of loads and resistances are different (e.g., dead load is less variable than wind load), and so these differences can be accounted for by use of multiple factors, and (2) by using probability theory designs can ideally achieve a more consistent reliability. Thus LRFD provides the basis for a more rational and refined design method than is possible with the Allowable Stress Design method.

#### Probabilistic Concepts

Factors of safety or load factors are provided against the uncertainties and variabilities which are inherent in the design process. Structural design consists of comparing nominal load effects  $Q$  to nominal resistances  $R$ , but both  $Q$  and  $R$  are random parameters (see Fig. CA5.1-1). A limit state is violated if  $R < Q$ . While the possibility of this event ever occurring is never zero, a successful design should, nevertheless, have only an acceptably small probability of exceeding the limit state. If the exact probability distrib-

utions of Q and R were known, then the probability of  $(R - Q) < 0$  could be exactly determined for any design. In general the distributions of Q and R are not known, and only the means,  $Q_m$  and  $R_m$ , and the standard deviations,  $\sigma_Q$  and  $\sigma_R$  are available. Nevertheless it is possible to determine relative reliabilities of several designs by the scheme illustrated in Fig. CA5.1-2. The distribution curve shown is for  $\ln(R/Q)$ , and a limit state is exceeded when  $\ln(R/Q) \leq 0$ . The area under  $\ln(R/Q) \leq 0$  is the probability of violating the limit state. The size of this area is dependent on the distance between the origin and the mean of  $\ln(R/Q)$ . For given statistical data  $R_m$ ,  $Q_m$ ,  $\sigma_R$  and  $\sigma_Q$ , the area under  $\ln(R/Q) \leq 0$  can be varied by changing the value of  $\beta$  (Fig. CA5.1-2), since  $\beta\sigma_{\ln(R/Q)} = \ln(R/Q)$ , from which approximately

$$\beta = \frac{\ln(R_m/Q_m)}{\sqrt{V_R^2 + V_Q^2}} \quad (\text{CA5.1-2})$$

where  $V_R = \sigma_R/R_m$  and  $V_Q = \sigma_Q/Q_m$ , the coefficients of variation of R and Q, respectively. The index  $\beta$  is called the "reliability index", and it is a relative measure of the safety of the design. When two designs are compared, the one with the larger  $\beta$  is more reliable.

The concept of the reliability index can be used in determining the relative reliability inherent in current design, and it can be used in testing out the reliability of new design formats, as illustrated by the following example of simply supported, braced beams subjected to dead and live loading.

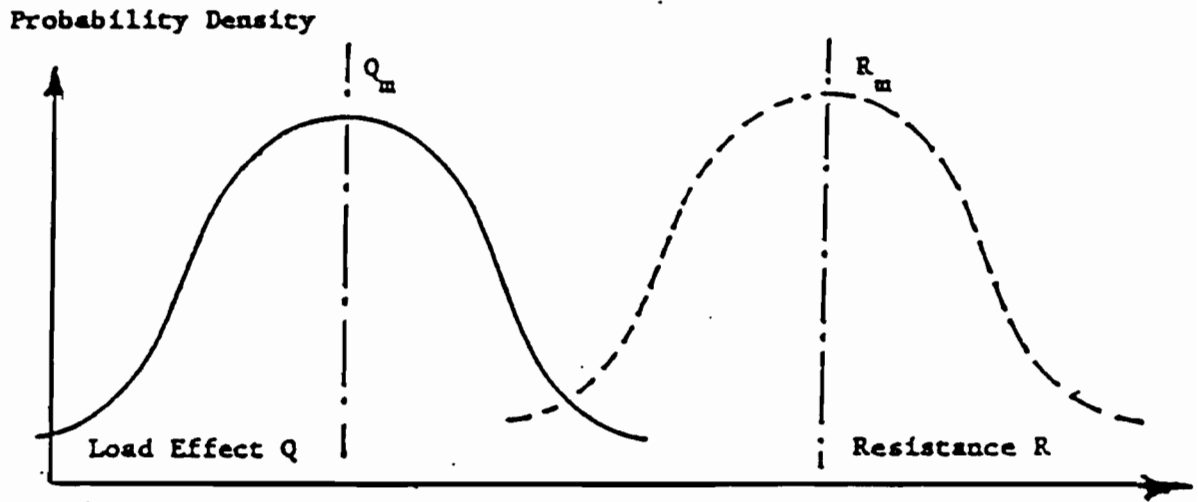

Fig. CA5.1-1 Definition of the Randomness of Q and R

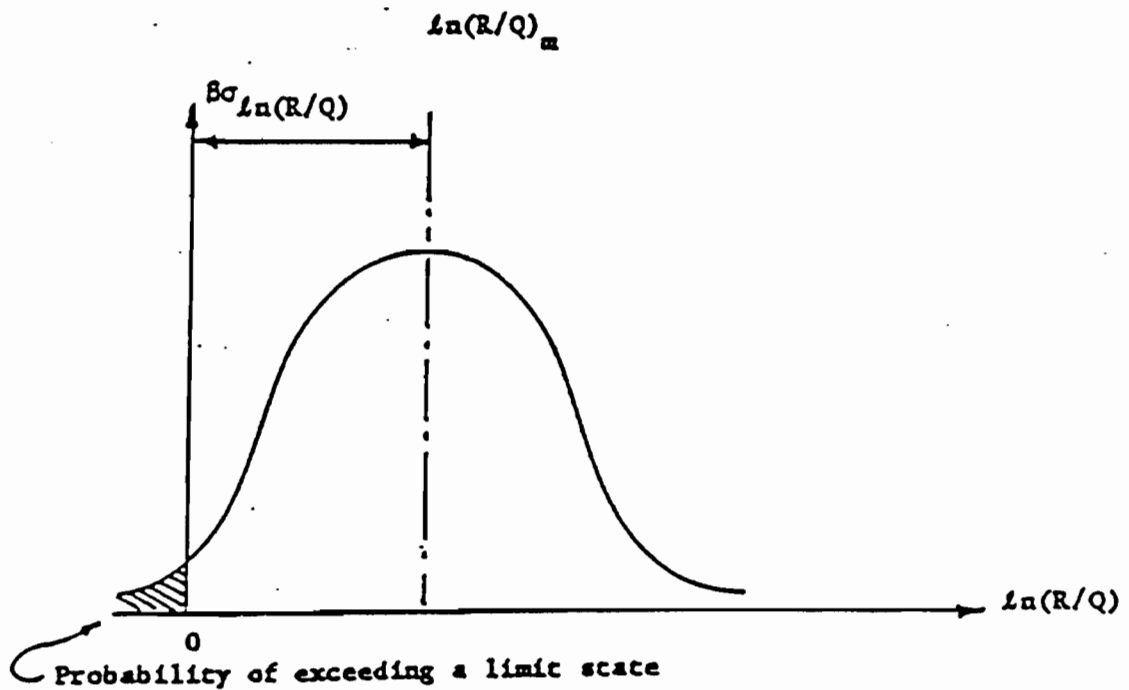

Fig. CA5.1-2 Definition of the Reliability Index  $\beta$

The design requirement of the 1986 AISI Specification for such a beam is

$$S_e F_y / FS = (L^2 s / 8) (D_n + L_n) \quad (CA5.1-3)$$

where

$S_e$  = elastic section modulus based on the effective section

FS = 5/3 = the factor of safety for bending

$F_y$  = specified yield point

L = span length, and s = beam spacing

$D_n$  and  $L_n$  are, respectively, the code specified dead and live load intensities.

The mean resistance is defined as (Ref. 9)

$$R_m = R_n (P_m M_m F_m) \quad (CA5.1-4)$$

In this equation  $R_n$  is the nominal resistance, which in this case is

$$R_n = S_e F_y \quad (CA5.1-5)$$

that is, the nominal moment predicted on the basis of the post-buckling strength of the compression flange. The mean values  $P_m$ ,  $M_m$ , and  $F_m$ , and the corresponding coefficients of variation  $V_P$ ,  $V_M$  and  $V_F$ , are the statistical parameters which define the variability of the resistance:

$P_m$  = the mean ratio of the experimentally determined moment to the predicted moment for the actual material and cross-sectional properties of the test specimens

$M_m$  = mean ratio of the yield point to the minimum specified value

$F_m$  = mean ratio of the actual section modulus to the specified (nominal) value

The coefficient of variation of R equals



$$V_R = \sqrt{V_P^2 + V_M^2 + V_F^2} \quad (\text{CA5.1-6})$$

The values of these data were obtained from examining the available tests on beams having different compression flanges with partially and fully effective flanges and webs, and from analyzing data on yield point values from tests and cross-sectional dimensions from many measurements. This information was developed in Ref. 10 and is given below:

$P_m = 1.11$ ,  $V_P = 0.09$ ;  $M_m = 1.10$ ,  $V_M = 0.10$ ;  $F_m = 1.0$ ,  $V_F = 0.05$  and thus  $R_m = 1.22R_n$  and  $V_R = 0.14$ .

The mean load effect is equal to

$$Q_m = (L_s^2/8)(D_m + L_m) \quad (\text{CA5.1-7})$$

and

$$V_Q = \frac{\sqrt{(D_m V_D)^2 + (L_m V_L)^2}}{D_m + L_m} \quad (\text{CA5.1-8})$$

where  $D_m$  and  $L_m$  are the mean dead and live load intensities, respectively, and  $V_D$  and  $V_L$  are the corresponding coefficients of variation.

Load statistics have been analyzed in Ref. 11, where it was shown that

$$D_m = 1.05D_n, \quad V_D = 0.1; \quad L_m = L_n, \quad V_L = 0.25.$$

The mean live load intensity equals the code live load intensity if the tributary area is small enough so that no live load reduction is included.

Substitution of the load statistics into Eqs. CA5.1-7 and CA5.1-8 gives

$$Q_m = \frac{L_s^2}{8} \left( \frac{1.05D_n}{L_n} + 1 \right) L_n \quad (\text{CA5.1-9})$$

$$V_Q = \frac{\sqrt{(1.05D_n/L_n)^2 V_D^2 + V_L^2}}{(1.05D_n/L_n + 1)} \quad (\text{CA5.1-10})$$

$Q_m$  and  $V_Q$  thus depend on the dead-to-live load ratio. Cold-formed beams typically have small  $D_n/L_n$ , and for the purposes of checking the reliability of these LRFD criteria it will be assumed that  $D_n/L_n = 1/5$ , and so  $Q_m = 1.21L_n(L^2s/8)$  and  $V_Q = 0.21$ .

From Eq. CA5.1-3 we obtain the nominal design capacity for  $D_n/L_n = 1/5$  and  $FS = 5/3$ . Thus

$$\frac{R_m}{Q_m} = \frac{1.22 \times 2.0 \times L_n(L^2s/8)}{1.21L_n(L^2s/8)} = 2.02$$

and, from Eq. CA5.1-2

$$\beta = \frac{\ln(2.02)}{\sqrt{0.14^2 + 0.21^2}} = 2.79$$

Of itself  $\beta = 2.79$  for beams having different compression flanges with partially and fully effective flanges and webs designed by the 1986 AISI Specification means nothing. However, when this is compared to  $\beta$  for other types of cold-formed members, and to  $\beta$  for designs of various types from hot-rolled steel shapes or even for other materials, then it is possible to say that this particular cold-formed steel beam has about an average reliability (Ref. 12).

### Basis for LRFD of Cold-Formed Steel Structures

A great deal of work has been performed for determining the values of the reliability index  $\beta$  inherent in traditional design as exemplified by the current structural design specifications such as the AISC Specification for hot-rolled steel, the AISI Specification for cold-formed steel, the ACI Code for reinforced concrete members, etc. The studies for hot-rolled steel are summarized in Ref 9, where also many further papers are referenced which contain additional data. The determination of  $\beta$  for cold-formed steel elements or members is presented in Refs. 10 and 13 through 17., where both the basic research data as well as the  $\beta$ 's inherent in the AISI Specification are presented in great detail. The  $\beta$ 's computed in the above referenced publications were developed with slightly different load statistics than those of this Commentary, but the essential conclusions remain the same.

The entire set of data for hot-rolled steel and cold-formed steel designs, as well as data for reinforced concrete, aluminum, laminated timber, and masonry walls was re-analyzed in Refs. 11, 12 and 18 by using a) updated load statistics and b) a more advanced level of probability analysis which was able to incorporate probability distributions which describe the true distributions more realistically. The details of this extensive reanalysis are presented in Refs. 11, 12 and 18 and also only the final conclusions from the analysis are summarized here:

- 1) The values of the reliability index  $\beta$  vary considerably for the different kinds of loading, the different types of construction, and the different types of members within a given material design specification. In order to achieve more consistent reliability, it was suggested in Ref. 18 that the following values of  $\beta$  would provide this improved consistency while at the same time give, on the average, essentially the same design by

the new LRFD method as is obtained by current design for all materials of construction. These target reliabilities  $\beta_o$  for use in LRFD are:

Basic case: Gravity loading,  $\beta_o = 3.0$

For connections:  $\beta_o = 4.5$

For wind loading:  $\beta_o = 2.5$

These target reliability indices are the ones inherent in the load factors recommended in the ANSI A58.1-82 Load Code (Ref. 19).

For cold-formed simply supported, braced steel beams with stiffened flanges, which were designed according to the 1986 AISI allowable stress design specification or to any previous version of this specification, it was shown above that for the representative dead-to-live load ratio of 1/5 the reliability index  $\beta = 2.8$ . Considering the fact that for other such load ratios, or for other types of members, the reliability index inherent in current cold-formed steel construction could be more or less than this value of 2.8, a somewhat lower target reliability index of  $\beta_o = 2.5$  is recommended as a lower limit for the new LRFD Specification. The resistance factors  $\phi$  were selected such that  $\beta_o = 2.5$  is essentially the lower bound of the actual  $\beta$ 's for members. In order to assure that failure of a structure is not initiated in the connections, a higher target reliability of  $\beta_o = 3.5$  is recommended for joints and fasteners. These two targets of 2.5 and 3.5 for members and connections, respectively, are somewhat lower than those recommended by ANSI A58.1-82 (i.e., 3.0 and 4.5, respectively), but they are essentially the same targets as are the basis for the 1986 AISC LRFD Specification (Ref. 3).

2) The following load factors and load combinations were developed in Refs. 11 and 18 to give essentially the same  $\beta$ 's as the target  $\beta_o$ 's, and are

recommended for use with the 1982 ANSI Load Code (Ref. 19) for all materials, including cold-formed steel:

1.  $1.4D_n$
2.  $1.2D_n + 1.6L_n + 0.5(L_{rn} \text{ or } S_n \text{ or } R_{rn})$
3.  $1.2D_n + 1.6(L_{rn} \text{ or } S_n \text{ or } R_{rn}) + (0.5L_n \text{ or } 0.8W_n)$
4.  $1.2D_n + 1.3W_n + 0.5L_n + 0.5(L_{rn} \text{ or } S_n \text{ or } R_{rn})$
5.  $1.2D_n + 1.5E_n + (0.5L_n \text{ or } 0.2S_n)$
6.  $0.9D_n - (1.3W_n \text{ or } 1.5E_n)$

where

$D_n$  = nominal dead load

$E_n$  = nominal earthquake load

$L_n$  = nominal live load due to occupancy;

weight of wet concrete for composite construction

$L_{rn}$  = nominal roof live load

$R_{rn}$  = nominal roof rain load

$S_n$  = nominal snow load

$W_n$  = nominal wind load

In view of the fact that the dead load of cold-formed steel structures is usually smaller than that of heavy construction, the first case of load combinations included in Section A5.1.4 of the Specification is  $(1.4D_n + L_n)$  instead of the ANSI value of  $1.4D_n$ . This AISI requirement is identical with the ANSI Code when  $L_n = 0$ .

Because of special circumstances inherent in cold-formed steel structures, the following additional LRFD criteria apply for roof, floor and wall construction using cold-formed steel:

- a) For roof and floor composite construction

$$1.2D_n + 1.6C_{wn} + 1.4C_n$$

where

$C_{wn}$  = nominal weight of wet concrete during construction

$C_n$  = nominal construction load, including equipment, workmen and formwork, but excluding the weight of the wet concrete.

This suggestion provides safe construction practices for cold-formed steel decks and panels which otherwise may be damaged during construction. The load factor used for the weight of wet concrete is 1.6 because it is frequently dumped into a pile or impacted onto the deck. An individual sheet can be subjected to this load. The use of a load factor of 1.4 for the construction load reflects a general practice of 33% strength increase for concentrated loads.

It should be noted that for the third case of load combinations, the load factor used for the nominal roof live load,  $L_{rn}$ , in Section A5.1.4 of the AISI Specification is 1.4 instead of the ANSI value of 1.6. The use of a relatively small load factor is because the roof live load is due to the presence of workmen and materials during repair operations and, therefore, can be considered as a type of construction load.

b) For roof and wall construction, the load factor for the nominal wind load  $W_n$  to be used for the design of individual purlins, girts, wall panels and roof decks should be multiplied by a reduction factor of 0.9 because these elements are secondary members subjected to a short duration of wind load and thus can be designed for a smaller reliability than primary members such as beams and columns. For example, the reliability index of a wall panel under wind load alone is approximately 1.5 with this reduction

factor. With this reduction factor designs comparable to current practice are obtained.

Deflection calculations for serviceability criteria should be made with the appropriate unfactored loads.

The load factors and load combinations given above are recommended for use with the LRFD criteria for cold-formed steel. The following portions of this Commentary present the background for the resistance factors  $\phi$  which are recommended in Section A5.1.5 for the various members and connections in Sections B, C, D and E. These  $\phi$  factors are determined in conformance with the load factors given above to approximately provide a target  $\beta_o$  of 2.5 for members and 3.5 for connections, respectively, for the load combination  $1.2D_n + 1.6L_n$ . For practical reasons it is desirable to have relatively few different resistance factors, and so the actual values of  $\beta$  will differ from the derived targets. This means that

$$\phi R_n = c(1.2D_n + 1.6L_n) = (1.2D_n/L_n + 1.6)cL_n \quad (\text{CA5.1-11})$$

where  $c$  is the deterministic influence coefficient translating load intensities to load effects.

By assuming  $D_n/L_n = 1/5$ , Eqs. CA5.1-11 and CA5.1-9 can be rewritten as follows:

$$R_n = 1.84(cL_n/\phi) \quad (\text{CA5.1-12})$$

$$Q_m = (1.05D_n/L_n + 1)cL_n = 1.21cL_n \quad (\text{CA5.1-13})$$

Therefore,

$$R_m/Q_m = (1.521/\phi)(R_m/R_n) \quad (\text{CA5.1-14})$$

The  $\phi$  factors can be computed from Eq. CA5.1-14 and the following equation

by using  $V_Q = 0.21$ :

$$\text{Target } \beta_o = \frac{\ln(R_m/Q_m)}{\sqrt{V_R^2 + V_Q^2}} \quad (\text{CA5.1-15})$$

## A5.2 Yield Point and Strength Increase from Cold Work of Forming

This section is the same as Section A5.2 of the 1986 AISI Specification.

The following statistical data (mean values and coefficients of variation) on material and cross-sectional properties were developed in Refs. 13 and 14 for use in the derivation of the resistance factors  $\phi$ :

$$\begin{aligned}(F_y)_m &= 1.10F_y; & M_m &= 1.10; & V_{F_y} &= V_M = 0.10 \\(F_{ya})_m &= 1.10F_{ya}; & M_m &= 1.10; & V_{F_{ya}} &= V_M = 0.11 \\(F_u)_m &= 1.10F_u; & M_m &= 1.10; & V_{F_u} &= V_M = 0.08 \\F_m &= 1.00; & V_F &= 0.05\end{aligned}$$

The subscript  $m$  refers to mean values. The symbol  $V$  stands for coefficient of variation. The symbols  $M$  and  $F$  are, respectively, the ratio of the mean-to-the nominal material property or cross-sectional property; and  $F_y$ ,  $F_{ya}$ , and  $F_u$  are, respectively, the specified minimum yield point, the average yield point including the effect of cold forming, and the specified minimum tensile strength.

These data are based on the analysis of many samples, and they are representative properties of materials and cross sections used in the industrial application of cold-formed steel structures.

## A6 Reference Documents

This section is primarily the same as Section A6 of the 1986 AISI Specification for allowable stress design. It should be noted that AISC Specification for load and resistance factor design is included in this section.



## B. ELEMENTS

### B1 Dimensional Limits and Considerations

This section is the same as Section B1 of the AISI Specification for allowable stress design.

### B2 Effective Widths of Stiffened Elements

This section is the same as Section B2 of the AISI Specification for allowable stress design.

### B3 Effective Widths of Unstiffened Elements

This section is the same as Section B3 of the AISI Specification for allowable stress design.

### B4 Effective Widths of Elements with an Edge Stiffener or One

Intermediate Stiffener

This section is the same as Section B4 of the AISI Specification for allowable stress design.

### B5 Effective Widths of Edge Stiffened Elements with Intermediate Stiffeners or Stiffened Elements with More Than One Intermediate Stiffener

This section is the same as Section B5 of the AISI Specification for allowable stress design.

## B6 Stiffeners

### B6.1 Transverse Stiffeners

The available experimental data on cold-formed steel transverse stiffeners were evaluated in Ref 10. The test results were compared to the predictions based on the same mathematical models on which the AISI Specification was based. The design provisions in these LRFD criteria are also based on the same mathematical models.

Load capacity in these LRFD criteria is based on the same prediction models as were employed in the formulation of the AISI Specification. A total of 61 tests were examined. The resistance factor  $\phi_c = 0.85$  was selected on the basis of the statistical data given in Ref. 10. The corresponding safety indices vary from 3.32 to 3.41. A summary of the information is given in Table CB6.1.

### B6.2 Shear Stiffeners

The available experimental data on shear strength of the beam webs with shear stiffeners were calibrated in Ref. 10. The  $\phi_v$  factors were taken as the same as those for shear strength of beams (Section C3.2). The statistical data used for determining the  $\phi_v$  factor are given in Ref. 10 as follows:

$$\begin{array}{ll} P_m = 1.60; & V_P = 0.09 \\ M_m = 1.00; & V_M = 0.06 \\ F_m = 1.00; & V_F = 0.05 \end{array}$$

Table CB6.1

Computed Safety Index  $\beta$  for Transverse Stiffeners  
 ( $\phi_c = 0.85$ )

Case	No. of Tests	$M_m$	$V_M$	$F_m$	$V_F$	$P_m$	$V_P$	$\beta$
1	33	1.10	0.10	1.0	0.05	1.1762	0.08658	3.32
2	28	1.10	0.10	1.0	0.05	1.2099	0.09073	3.41
3	61	1.10	0.10	1.0	0.05	1.1916	0.08897	3.36

Note: Case 1 = Transverse stiffeners at interior support and under concentrated load  
 Case 2 = Transverse stiffeners at end support  
 Case 3 = Sum of Cases 1 and 2

Based on all these data, the value of  $\beta$  was found to be 4.10 for  $\phi_v = 0.90$ .

### B6.3 Non-Conforming Stiffeners

This Section is the same as Section B6.3 of the AISI Specification for allowable stress design.

## C. MEMBERS

### C1 Properties of Sections

This section is the same as Section C1 of the AISI Specification for allowable stress design.

## C2 Tension Members

Section C2 of the LRFD criteria was developed on the basis of Section C2 of the AISI Specification for allowable stress design, in which the design of tension members is based only on the yield point of steel.

The resistance factor of  $\phi_t = 0.95$  used for tension member design was derived from the procedure described in Section A5.1 of this Commentary and a selected  $\beta_o$  value of 2.5. In the determination of the resistance factor, the following formulas were used for  $R_m$  and  $R_n$ :

$$R_m = A_n (F_y)_m \quad (\text{CC2-1})$$

$$R_n = A_n F_y \quad (\text{CC2-2})$$

$$\text{i.e. } R_m/R_n = (F_y)_m/F_y \quad (\text{CC2-3})$$

in which  $A_n$  is the net area of the cross section,  $(F_y)_m$  is equal to  $1.10F_y$  as discussed in Section A5.2 of the Commentary. By using  $V_M = 0.10$ ,  $V_F = 0.05$  and  $V_P = 0$ , the coefficient of variation  $V_R$  is:

$$V_R = \sqrt{V_M^2 + V_F^2 + V_P^2} = 0.11 \quad (\text{CC2-4})$$

Based on  $V_Q = 0.21$  and the resistance factor of 0.95, the value of  $\beta$  is 2.4, which is close to the stated target value of  $\beta_o = 2.5$ .

## C3 Flexural Members

### C3.1 Strength for Bending Only

Bending strengths of flexural members are differentiated according to whether or not the member is laterally braced. If such members are laterally supported, then they are proportioned according to the nominal section strength (Sec. C3.1.1). If they are laterally unbraced, then the limit state is lateral-torsional buckling (Sec. C3.1.2). For C- or Z-section with the tension flange attached to deck or sheathing and with compression flange laterally unbraced, the bending capacity is less than that of a fully braced member but greater than that of an unbraced member (Sec. C3.1.3).

#### C3.1.1 Nominal Section Strength

The bending strength of beams with a compression flange having stiffened, partially stiffened, or unstiffened elements is based on the post-buckling strength of the member, and use is made in LRFD of the effective width concept in the same way as in the 1986 AISI Specification. References 5, 6, 7, and 8 provide an extensive treatment of the background research.

The experimental bases for the post-buckling strengths of cold-formed beams were examined in Refs. 8 and 10, where different cases were studied according to the types of compression flanges and the effectiveness of webs.

On the basis of the initiation of yielding, the nominal strength  $R_n$  is based on the nominal effective cross section and on the specified minimum yield point, i.e.,  $R_n = S_e F_y$ .

Table CC3.1.1

Computed Safety Index  $\beta$  for Section Bending Strength of Beams  
Based on Initiation of Yielding

Case	No. of Tests	$M_m$	$V_M$	$F_m$	$V_F$	$P_m$	$V_P$	$\beta$
Stiffened or Partially Stiffened Compression Flanges ( $\phi_b = 0.95$ )								
FF. FW.	8	1.10	0.10	1.0	0.05	1.10543	0.03928	2.76
PF. FW.	30	1.10	0.10	1.0	0.05	1.11400	0.08889	2.65
PF. PW.	5	1.10	0.10	1.0	0.05	1.08162	0.09157	2.53
Unstiffened Compression Flanges ( $\phi_b = 0.90$ )								
FF. FW.	3	1.10	0.10	1.0	0.05	1.43330	0.04337	4.05
PF. FW.	40	1.10	0.10	1.0	0.05	1.12384	0.13923	2.67
PF. PW.	10	1.10	0.10	1.0	0.05	1.03162	0.05538	2.66

Note: FF. = Fully effective flanges  
 PF. = Partially effective flanges  
 FW. = Fully effective webs  
 PW. = Partially effective webs  
 For details, see Ref. 10.

The computed values of  $\beta$  for the selected values of  $\phi_b = 0.95$  for sections with stiffened or partially stiffened compression flanges and 0.90 for sections with unstiffened compression flanges, and for a dead-to-live load ratio of 1/5 for different cases are listed in Table CC3.1.1. It can be seen that the  $\beta$  values vary from 2.53 to 4.05. In Table CC3.1.1, the values of  $M_m$ ,  $V_M$ ,  $F_m$  and  $V_F$  are the values presented in Sec. A5.2 of this Commentary for the material strength.

#### C3.1.2 Lateral Buckling Strength

There are not many test data on laterally unsupported cold-formed beams. The available test results are summarized in Ref. 10, and they are compared with predictions from AISI design formulas, theoretical formulas and SSRC formulas.

The statistical data used in Ref. 10 are listed in Table CC3.1.2. The symbol  $P$  is the ratio of the tested capacity to the predicted value,  $M$  is the ratio of the actual to the specified value of the modulus of elasticity, and  $F$  is the ratio of the actual to the nominal sectional properties.

Using the recommended resistance factor  $\phi_b = 0.90$ , the values of  $\beta$  vary from 2.35 to 3.8. See Table CC3.1.2. It should be noted that the recommended design criteria use some simplified and conservative formulas, which are the same as the allowable stress design rules included in the 1986 AISI Specification.

#### C3.1.3 Beams Having One Flange Through-Fastened to Deck or Sheathing

For beams having the tension flange attached to deck or sheathing and the compression flange unbraced, e.g., a roof purlin or wall girt subjected to wind suction, the bending capacity is less than that of a fully braced

member, but greater than that of an unbraced member. This partial restraint is a function of the rotational stiffness provided by the panel-to-purlin connection. The Specification contains factors that represent the reduction in capacity from a fully braced condition. These factors are based on experimental results obtained for both simple and continuous span purlins (Refs. 20 to 24).

As indicated in Ref. 25, the rotational stiffness of the panel-to-purlin connection is primarily a function of the member thickness, sheet thickness, fastener type and fastener location. For fiber glass blanket insulation thicknesses of zero to six inches, the rotational stiffness was not measurably affected (Ref. 25). To ensure adequate rotational stiffness for the roof and wall systems designed using the Specification provision, Section C3.1.3 explicitly states the acceptable panel and fastener types.

Continuous beam tests were made on three equal spans and the R values were calculated from the failure loads, using a maximum positive moment,  $M = 0.08wL^2$ .

The provisions of Section C3.1.3 apply to beams on which the tension flange is attached to deck or sheathing and the compression flange is completely unbraced. Beams with discrete point braces on the compression flange may have a bending capacity greater than those completely unbraced. Available data from simple span tests (Refs. 20, 23, 37, and 38) indicate that for members having a lip edge stiffener at an angle of 75 degrees or greater with the plane of the compression flange and braces to the compression flange located at third points or more frequently member capacities are increased from 25% to 40% over those without such discrete braces. For members with lip angles less than 75 degrees or braces spaced further than third point



the data availability is insufficient to allow the benefit of bracing to be assessed.

In this section, the  $\phi_b$  factor is determined for the load combination of  $1.17W_n - 0.9D_n$  to approximately provide a target  $\beta_o$  of 1.5 for counteracting loads with a reduction factor of 0.9 applied to the load factor for the nominal wind load. The reasons for using a low target  $\beta_o$  are discussed in Section A5.1 of this Commentary. Based on this type of load combination, the following equations can be established:

$$\phi R_n = c(1.17W_n - 0.9D_n) = (1.17 - 0.9D_n/W_n)cW_n \quad (\text{CC3.1.3-1})$$

$$Q_m = c(W_m - D_m) \quad (\text{CC3.1.3-2})$$

$$V_Q = \frac{\sqrt{(W_m V_W)^2 + (D_m V_D)^2}}{W_m - D_m} \quad (\text{CC3.1.3-3})$$

where  $W_m$  is the mean wind load intensity and  $V_W$  is the corresponding coefficient of variation.

Load statistics have been analyzed in Ref. 11, where it was shown that

$$D_m = 1.05D_n, V_D = 0.1; W_m = 0.78W_n, V_W = 0.37$$

The substitution of the load statistics into Eqs. CC3.1.3-2 and CC3.1.3-3 gives

$$Q_m = c(0.78W_n - 1.05D_n) = (0.78 - 1.05D_n/W_n)cW_n \quad (\text{CC3.1.3-4})$$

$$V_Q = \frac{\sqrt{(0.78 \times 0.37)^2 + (1.05D_n/W_n \times 0.1)^2}}{0.78 - 1.05D_n/W_n} \quad (\text{CC3.1.3-5})$$

By assuming  $D_n/W_n = 0.1$ , Eqs. CC3.1.3-1, CC3.1.3-4, and CC3.1.3-5 can be rewritten as follows:

$$\begin{aligned} \phi R_n &= 1.08cW_n \\ Q_m &= 0.675cW_n = 0.675(\phi R_n/1.08) = 0.625\phi R_n \end{aligned} \quad (\text{CC3.1.3-6})$$

$$V_Q = 0.43$$

The application of Eqs. CA5.1-2, CA5.1-4, CC3.1.3-6, and CA5.1-6 gives

$$\beta = \frac{\ln(1.6M_m F_m P_m / \phi)}{\sqrt{V_M^2 + V_F^2 + V_P^2 + V_Q^2}} \quad (\text{CC3.1.3-7})$$

or

$$\phi = 1.6(M_m F_m P_m) \exp(-\beta \sqrt{V_M^2 + V_F^2 + V_P^2 + V_Q^2}) \quad (\text{CC3.1.3-8})$$

The computed values of  $\beta$  for the selected value of  $\phi_b = 0.90$  for different cases are listed in Table CC3.1.3. It can be seen that the  $\beta$  values vary from 1.50 to 1.60 which are satisfactory for the target value of 1.5. In Table CC3.1.3, the values of  $M_m$ ,  $V_M$ ,  $F_m$ , and  $V_F$  are the values presented in Section A5.2 of this Commentary for the material strength and fabrication.

### C3.2 Strength for Shear Only

The shear strength of beam webs is governed by either yielding or buckling, depending on the  $h/t$  ratio and the mechanical properties of steel. For beam webs having small  $h/t$  ratios, the shear strength is governed by shear yielding, i.e.:

$$V_n = A_w \tau_y = A_w F_y / \sqrt{3} = 0.577 F_y h t \quad (\text{CC3.2-1})$$

in which  $A_w$  is the area of the beam web computed by  $(hxt)$ , and  $\tau_y$  is the yield point of steel in shear, which can be computed by  $F_y / \sqrt{3}$ .

For beam webs having large  $h/t$  ratios, the shear strength is governed by elastic shear buckling, i.e.:

$$V_n = A_w \tau_{cr} = \frac{k_v \pi^2 E A_w}{12(1-\mu^2)(h/t)^2} \quad (\text{CC3.2-2})$$

in which  $\tau_{cr}$  is the critical shear buckling stress in the elastic range,  $k_v$  is the shear buckling coefficient,  $E$  is the modulus of elasticity,  $\mu$  is the Poisson's ratio,  $h$  is the web depth, and  $t$  is the web thickness. By using  $\mu = 0.3$ , the shear strength,  $V_n$ , can be determined as follows:

$$V_n = 0.905Ek_v t^3/h \quad (\text{CC3.2-3})$$

For beam webs having moderate  $h/t$  ratios, the shear strength is based on the inelastic buckling, i.e.:

$$V_n = 0.64t^2 \sqrt{k_v F_y E} \quad (\text{CC3.2-4})$$

In view of the fact that the appropriate test data on shear are not available, the  $\phi_v$  factors used in Section C3.2 were derived from the condition that the nominal resistance for the LRFD method is the same as the nominal resistance for the allowable stress design method. Thus,

$$(R_n)_{\text{LRFD}} = (R_n)_{\text{ASD}} \quad (\text{CC3.2-5})$$

$$\text{Since } (R_n)_{\text{LRFD}} \geq c(1.2D_n + 1.6L_n)/\phi_v \quad (\text{CC3.2-6})$$

$$(R_n)_{\text{ASD}} \geq c(\text{F.S.})(D_n + L_n) \quad (\text{CC3.2-7})$$

the resistance factors can be computed from the following formula:

$$\begin{aligned} \phi_v &= \frac{1.2D_n + 1.6L_n}{(\text{F.S.})(D_n + L_n)} \\ &= \frac{1.2(D_n/L_n) + 1.6}{(\text{F.S.})(D_n/L_n + 1)} \end{aligned} \quad (\text{CC3.2-8})$$

By using a dead-to-live load ratio of  $D_n/L_n = 1/5$ , the  $\phi_v$  factors computed from the above equation are listed in Table CC3.2 for three dif-

ferent ranges of  $h/t$  ratios. The factors of safety are adopted from the AISI Specification for allowable stress design. It should be noted that the use of a small safety factor of 1.44 for yielding in shear is justified by long standing use and by the minor consequences of incipient yielding in shear compared with those associated with yielding in tension and compression.

### C3.3 Strength for Combined Bending and Shear

This section is based on the interaction formulas included in Section C3.3 of the AISI Specification for allowable stress design.

### C3.4 Web Crippling Strength

The nominal concentrated load or reaction,  $P_n$ , is determined by the allowable load given in Section C3.4 of the AISI Specification times the appropriate factor of safety. In this regard, a factor of safety of 1.85 is used for Eqs. C3.4-1, C3.4-2, C3.4-4, C3.4-6 and C3.4-8, and a factor of safety of 2.0 is used for Eqs. C3.4-3, C3.4-5, C3.4-7 and C3.4-9.

On the basis of the statistical analysis of the available test data on web crippling, the values of  $P_m$ ,  $M_m$ ,  $F_m$ ,  $V_p$ ,  $V_M$  and  $V_F$  were computed and selected. These values are presented in Table CC3.4 (see Table 76 of Ref. 10). By using  $\beta_o = 2.5$ , the resistance factors  $\phi_w = 0.75$  and  $0.80$  were selected for single unreinforced webs and I-sections, respectively, and is used in Sections A5.1.5 and C3.4. The values of  $\beta$  corresponding to these values of  $\phi_w$  are also given in Table CC3.4.

Table CC3.1.2

Computed Safety Index  $\beta$  for Lateral Buckling Strength of Bending  
 ( $\phi_b = 0.90$ )

Case	No. of Tests	$M_m$	$V_M$	$F_m$	$V_F$	$P_m$	$V_P$	$\beta$
1	47	1.0	0.06	1.0	0.05	2.5213	0.30955	3.79
2	47	1.0	0.06	1.0	0.05	1.2359	0.19494	2.48
3	47	1.0	0.06	1.0	0.05	1.1800	0.19000	2.35
4	47	1.0	0.06	1.0	0.05	1.7951	0.21994	3.53
5	47	1.0	0.06	1.0	0.05	1.8782	0.20534	3.80

Note: Case 1 = AISI approach

Case 2 = Theoretical approach with  $J = 0.0026 \text{ in.}^4$

Case 3 = SSRC approach with  $J = 0.0026 \text{ in.}^4$

Case 4 = Theoretical approach with  $J = 0.0008213 \text{ in.}^4$

Case 5 = SSRC approach with  $J = 0.0008213 \text{ in.}^4$

Table CC3.1.3

Computed Safety Index  $\beta$  for Beams Having One Flange  
Through-Fastened to Deck or Sheathing  
( $\phi_b = 0.90$ )

Case	No. of Tests	$M_m$	$V_M$	$F_m$	$V_F$	$P_m$	$V_P$	$\beta$
1	5	1.10	0.10	1.0	0.05	1.1995	0.2991	1.60
2	15	1.10	0.10	1.0	0.05	1.0128	0.1112	1.50
3	5	1.10	0.10	1.0	0.05	1.0466	0.1010	1.58
4	14	1.10	0.10	1.0	0.05	1.0034	0.0689	1.51

Note: Case 1 = Simple span C-sections  
Case 2 = Simple span Z-sections  
Case 3 = Continuous span C-sections  
Case 4 = Continuous span Z-sections

Table CC3.2

Range of h/t Ratio	F.S. for Allowable Load Design	$\phi_v$ Factor computed by Eq. CC3.2-8	Recommended $\phi_v$ Factor
$h/t \leq \sqrt{Ek_v/F_y}$	1.44	1.06	1.00
$\sqrt{Ek_v/F_y} \leq h/t \leq 1.415\sqrt{Ek_v/F_y}$	1.67	0.92	0.90
$h/t > 1.415\sqrt{Ek_v/F_y}$	1.71	0.90	0.90

Table CC3.4

Computed Safety Index  $\beta$  for Web Crippling Strength of Beams

Case	No. of Tests	$M_m$	$V_M$	$F_m$	$V_F$	$P_m$	$V_P$	$\beta$
Single, Unreinforced Webs ( $\phi_w = 0.75$ )								
1(SF)	68	1.10	0.10	1.0	0.05	1.00	0.12	3.01
1(UF)	30	1.10	0.10	1.0	0.05	1.00	0.16	2.80
2(UMR)	54	1.10	0.10	1.0	0.05	0.99	0.11	3.02
2(CA)	38	1.10	0.10	1.0	0.05	0.86	0.14	2.36
2(SUM)	92	1.10	0.10	1.0	0.05	0.94	0.14	2.67
3(UMR)	26	1.10	0.10	1.0	0.05	0.99	0.09	3.11
3(CA)	63	1.10	0.10	1.0	0.05	1.72	0.26	3.80
3(SUM)	89	1.10	0.10	1.0	0.05	1.51	0.34	2.95
4(UMR)	26	1.10	0.10	1.0	0.05	0.98	0.10	3.03
4(CA)	70	1.10	0.10	1.0	0.05	1.04	0.26	2.39
4(SUM)	96	1.10	0.10	1.0	0.05	1.02	0.23	2.49
I-Sections ( $\phi_w = 0.80$ )								
1	72	1.10	0.10	1.0	0.05	1.10	0.19	2.74
2	27	1.10	0.10	1.0	0.05	0.96	0.13	2.57
3	53	1.10	0.10	1.0	0.05	1.01	0.13	2.76
4	62	1.10	0.10	1.0	0.05	1.02	0.11	2.89

Note: Case 1 = End one-flange loading  
Case 2 = Interior one-flange loading  
Case 3 = End two-flange loading  
Case 4 = Interior two-flange loading  
SF = Stiffened flanges  
UF = Unstiffened flanges  
UMR = UMR and Cornell tests only  
CA = Canadian tests only  
SUM = Combine UMR and Canadian tests together

### C3.5 Combined Bending and Web Crippling Strength

This section is based on the interaction formulas included in Section C3.5 of the AISI Specification for allowable stress design.

A total of 551 tests were calibrated for combined bending and web crippling strength. Six different cases were studied. Based on  $\phi_w = 0.75$  for single unreinforced webs and  $\phi_w = 0.80$  for I-sections, the value of safety indices vary from 2.45 to 3.27 as given in Table CC3.5.

### C4 Concentrically Loaded Compression Members

The available experimental data on cold-formed steel concentrically loaded compression members were evaluated in Ref 10. The test results were compared to the predictions based on the same mathematical models on which the AISI Specification was based. The design provisions in these LRFD criteria are also based on the same mathematical models.

Column capacity in these LRFD criteria is based on the same prediction models as were employed in the formulation of the AISI Specification. A total of 264 tests were examined; 14 different cases were studied according to the types of the column, the types of the compression flanges and the failure modes. The resistance factor  $\phi_c = 0.85$  was selected on the basis of the statistical data given in Ref. 10. The corresponding safety indices vary from 2.39 to 3.34. A summary of the information is given in Table CC4.

The safety indices were determined from Eq. CA5.1-2 for a  $D_n/L_n$  ratio of 1/5. Different  $\phi_c$  factors could have been used for different cases.



Table CC3.5

Computed Safety Index  $\beta$  for Combined Bending and Web Crippling

Case	No. of Tests	$M_m$	$V_M$	$F_m$	$V_F$	$P_m$	$V_P$	$\beta$
Single, Unreinforced Webs (Interior one-flange loading) (Based on $\phi_w = 0.75$ )								
1	74	1.10	0.10	1.0	0.05	1.01	0.07	3.27
2	202	1.10	0.10	1.0	0.05	0.87	0.13	2.45
3	103	1.10	0.10	1.0	0.05	0.95	0.10	2.91
4	66	1.10	0.10	1.0	0.05	1.03	0.18	2.79
5	445	1.10	0.10	1.0	0.05	0.94	0.14	2.68
I-Sections (Interior one-flange loading) (Based on $\phi_w = 0.80$ )								
1	106	1.10	0.10	1.0	0.05	1.06	0.12	2.99

Note: Case 1 = UMR and Cornell tests only  
Case 2 = Canadian brake-formed section tests only  
Case 3 = Canadian roll-formed section tests only  
Case 4 = Høglund's tests only  
Case 5 = Combine all tests together

Table CC4  
 Computed Safety Index  $\beta$  for Concentrically Loaded Compression Member  
 (  $\phi_c = 0.85$  )

Case	No. of Tests	$M_m$	$V_M$	$F_m$	$V_F$	$P_m$	$V_P$	$\beta$
1	5	1.10	0.10	1.0	0.05	1.14610	0.10452	3.13
2	24	1.10	0.10	1.0	0.05	1.05053	0.07971	2.89
3	15	1.10	0.10	1.0	0.05	1.05523	0.07488	2.93
4	3	1.10	0.10	1.0	0.05	1.10550	0.07601	3.11
5	28	1.10	0.10	1.0	0.05	1.04750	0.11072	2.76
6	25	1.10	0.10	1.0	0.05	1.22391	0.21814	2.72
7	9	1.00	0.06	1.0	0.05	0.96330	0.04424	2.39
8	41	1.10	0.10	1.0	0.05	1.19620	0.09608	3.34
9	18	1.10	0.10	1.0	0.05	1.02900	0.08131	2.81
10	12	1.10	0.11	1.0	0.05	1.06180	0.11062	2.77
11	8	1.00	0.06	1.0	0.05	1.15290	0.10544	2.92
12	30	1.10	0.10	1.0	0.05	1.07960	0.15061	2.68
13	14	1.10	0.10	1.0	0.05	1.07930	0.08042	3.00
14	32	1.10	0.10	1.0	0.05	1.08050	0.10772	2.89

- Note: Case 1 = Stub columns having unstiffened flanges with fully effective widths  
 Case 2 = Stub columns having unstiffened flanges with partially effective widths  
 Case 3 = Thin plates with partially effective widths  
 Case 4 = Stub columns having stiffened compression flanges with fully effective flanges and webs  
 Case 5 = Stub columns having stiffened compression flanges with partially effective flanges and fully effective webs  
 Case 6 = Stub columns having stiffened compression flanges with partially effective flanges and partially effective webs  
 Case 7 = Long columns having unstiffened compression flanges subjected to elastic flexural buckling  
 Case 8 = Long columns having unstiffened compression flanges subjected to inelastic flexural buckling  
 Case 9 = Long columns having stiffened compression flanges subjected to inelastic flexural buckling  
 Case 10 = Long columns subjected to inelastic flexural buckling (include cold-work)  
 Case 11 = Long columns subjected to elastic torsional-flexural buckling  
 Case 12 = Long columns subjected to inelastic torsional-flexural buckling  
 Case 13 = Stub columns with circular perforations  
 Case 14 = Long columns with circular perforations

## C5 Combined Axial Load and Bending

The LRFD Specification provide the similar interaction equations as the 1986 Edition of the AISI Specification.

A total of 144 tests were calibrated for combined axial load and bending. Nine different cases were studied according to the types of sections, the stable conditions and the loading conditions. Based on  $\phi_c = 0.85$ ,  $\phi_b = 0.95$  or  $0.90$  for nominal section strength (see Section C3.1.1), and  $\phi_b = 0.90$  for lateral buckling strength, the values of safety indices vary from 2.7 to 3.34 as given in Table CC5.

## C6 Cylindrical Tubular Members

Section C6 of the LRFD criteria is based on Section C6 of the AISI Specification for allowable stress design.

The  $\phi_b$  factor of 0.95 used in Section C6.1 for bending is the same as that used in Section C3.1.1, while the  $\phi_c$  factor of 0.85 used in Section C6.2 for compression is the same as that used in Section C4 for concentrically loaded compression members.

## D. STRUCTURAL ASSEMBLIES

### D1 Built-Up Sections

This section is the same as Section D1 of the AISI Specification for allowable stress design.

Table CC5  
 Computed Safety Index  $\beta$  for Combined Axial Load and Bending  
 ( based on  $\phi_c = 0.85$  )

Case	No. of Tests	$M_m$	$V_M$	$F_m$	$V_F$	$P_m$	$V_P$	$\beta$
1	18	1.05	0.10	1.0	0.05	1.0367	0.06619	2.70
2	13	1.05	0.10	1.0	0.05	1.0509	0.07792	2.72
3	33	1.05	0.10	1.0	0.05	1.1028	0.09182	2.86
4	18	1.05	0.10	1.0	0.05	1.1489	0.10478	2.96
5	6	1.05	0.10	1.0	0.05	1.1600	0.13000	2.87
6	17	1.05	0.10	1.0	0.05	1.1200	0.09000	2.92
7	10	1.05	0.10	1.0	0.05	1.2300	0.08000	3.34
8	17	1.05	0.10	1.0	0.05	1.0910	0.07950	2.86
9	12	1.05	0.10	1.0	0.05	1.1110	0.11450	2.79

Note: Case 1 = Locally stable beam-columns, hat sections of Pekoz and Winter (1967)<sup>26</sup>  
 Case 2 = Locally unstable beam-columns, lipped channel sections of Thomasson (1978)<sup>27</sup>  
 Case 3 = Locally unstable beam-columns, lipped channel sections of Loughlan (1979)<sup>28</sup>  
 Case 4 = Locally unstable beam-columns, lipped channel sections of Mulligan and Pekoz (1983)<sup>29</sup>  
 Case 5 = Locally stable beam-columns, lipped channel sections of Loh and Pekoz (1985)<sup>30</sup> with  $e_x \neq 0$  and  $e_y = 0$   
 Case 6 = Locally stable beam-columns, lipped channel sections of Loh and Pekoz (1985) with  $e_x = 0$  and  $e_y \neq 0$   
 Case 7 = Locally stable beam-columns, lipped channel sections of Loh and Pekoz (1985) with  $e_x \neq 0$  and  $e_y \neq 0$   
 Case 8 = Locally unstable beam-columns, lipped channel sections of Loh and Pekoz (1985) with  $e_x = 0$  and  $e_y \neq 0$   
 Case 9 = Locally unstable beam-columns, lipped channel sections of Loh and Pekoz (1985) with  $e_x \neq 0$  and  $e_y \neq 0$

## D2 Mixed Systems

This section is the same as Section D2 of the AISI Specification for allowable stress design.

## D3 Lateral Bracing

This section is the same as Section D3 of the AISI Specification for allowable stress design.

With regard to the footnote for Section D3.2, it should be noted that in conventional metal building roof systems, the roof panels are attached to the top flange of each purlin throughout its length using self-drilling or self-tapping, through-the-sheet, fasteners spaced at approximately 1 foot on center. This panel usually provides sufficient stiffness to prevent the relative movement of the purlins with respect to each other, however, unless external restraint is provided, the system as a whole will tend to move laterally. This restraint or anchorage may consist of members attached to the purlin at discrete locations along the span and designed to carry forces necessary to restrain the system against lateral movement. The design rules for Z-purlin supported roof systems are based on a first order, elastic stiffness model (Reference 31).

## D4 Wall Studs and Wall Stud Assemblies

### D4.1 Wall Studs in Compression

The AISI design provisions on the compression strength of wall studs were calibrated in Ref. 10. The statistical data used for determining the  $\phi_c$  factor are given in Ref. 10 as follows:

$$P_m = 1.14; \quad V_P = 0.10$$

$$M_m = 1.10; \quad V_M = 0.10$$

$$F_m = 1.00; \quad V_F = 0.05$$

Based on all these data and  $\phi_c = 0.85$ , the  $\beta$  value was found to be 3.14.

The provisions in this Specification section are given to prevent three possible modes of failure. Provision (a) is for column buckling between fasteners, even if one fastener is missing or otherwise ineffective. Provision (b) contains formulas for nominal axial strengths for overall column buckling. Essential to these provisions is the magnitude of the shear rigidity of the sheathing material.

A table of shearing parameters and an equation for determining the shear rigidity are provided in this Specification. These values are based on the small scale tests described in References 32 and 33. For other types of materials, the sheathing parameters can be determined using the procedures described in these references.

Provision (c) is to insure that the sheathing has sufficient distortion capacity. The procedure involves assuming a value of the stress and checking whether the shear strain at the load corresponding to the stress exceeds the permissible design shear strain of the sheathing material. In principle, the procedure is one of successive approximations. However, if the smaller of  $F_e$  (provision a) or  $\sigma_{cr}$  (provision b) is tried and shown to be satisfactory, then the need for iteration is eliminated.

The  $\phi_b$  factors for bending strength of wall studs were taken as the same as those for section bending strength of beams (Section C3.1.1). The available test data on wall stud sections with stiffened or partially stiffened compression flanges were calibrated in Ref. 10. The statistical data used for determining the  $\beta$  value are given in Ref. 10 as follows:

$$\begin{array}{ll} P_m = 1.27; & V_P = 0.01 \\ M_m = 1.10; & V_M = 0.10 \\ F_m = 1.00; & V_F = 0.05 \end{array}$$

Based on all these data and  $\phi_b = 0.95$ , the  $\beta$  value was found to be 3.37.

#### D4.3 Wall Studs with Combined Axial Load and Bending

The LRFD criteria provide the same interaction equations as the AISI Specification for allowable stress design.

The available test data on wall studs with combined axial load and bending were calibrated in Ref. 10. The statistical data used for determining the  $\beta$  value are given in Ref. 10 as follows:

$$\begin{array}{ll} P_m = 1.19; & V_P = 0.13 \\ M_m = 1.05; & V_M = 0.10 \\ F_m = 1.00; & V_F = 0.05 \end{array}$$

Based on  $\phi_c = 0.85$  and  $\phi_b = 0.95$  for sections with stiffened or partially stiffened compression flanges or  $\phi_b = 0.90$  for sections with unstiffened compression flanges, the  $\beta$  value was found to be 2.94.

### E. CONNECTIONS AND JOINTS

Section E of the LRFD criteria is based on Section E of the AISI Specification for allowable stress design. This section contains the design

provisions for welded connections, bolted connections, shear rupture and connections to other materials.

The resistance factors used for welded and bolted connections were derived for a target reliability index  $\beta_o = 3.5$  and the statistical data are summarized in the subsequent sections.

#### E1 General Provisions

This section is based on Section E1 of the AISI Specification for allowable stress design.

#### E2 Welded Connections

Section E2 contains the design provisions for arc-welds (groove welds in butt joints, arc spot welds, arc seam welds, fillet welds, and flare groove welds) and resistance welds. The design equations for the nominal strength and the  $\phi$  factors for groove welds in butt joints are the same as that used in the AISC LRFD criteria. (Ref. 3)

For arc spot welds, the  $\phi$  factor of 0.60 used for determining the design shear strength of welds is based on the test data reported in Ref. 34. It gives a  $\beta$  value of 3.55. The statistical data used for deriving the  $\phi$  factor are given in Ref 10 as follows:

$$\begin{array}{ll} P_m = 1.17; & V_P = 0.22 \\ M_m = 1.10; & V_M = 0.10 \\ F_m = 1.00; & V_F = 0.10 \end{array}$$



Table CE2

Computed Safety Index  $\beta$  for Plate Failure in Weld Connections

Case	$M_m$	$V_M$	$F_m$	$V_F$	$P_m$	$V_P$	$\phi$	$\beta$
Arc Spot Welds								
1	1.10	0.08	1.00	0.15	1.10	0.17	0.60	3.52
2	1.10	0.08	1.00	0.15	0.98	0.18	0.50	3.64
Fillet Welds								
3	1.10	0.08	1.00	0.15	1.01	0.08	0.60	3.65
4	1.10	0.08	1.00	0.15	0.89	0.09	0.55	3.59
5	1.10	0.08	1.00	0.15	1.05	0.11	0.60	3.72

Note: Case 1 = For  $d_a/t \leq 0.815\sqrt{(E/F_u)}$

Case 2 = For  $d_a/t > 1.397\sqrt{(E/F_u)}$

Case 3 = Longitudinal Loading,  $L/t < 25$

Case 4 = Longitudinal Loading,  $L/t \geq 25$

Case 5 = Transverse Loading

With regard to the types of the plate failure governed by Eqs. E2.2-2 through Eq. E2.2-4 in the design criteria,  $\phi$  factors were derived from the statistical data presented in Table CE2 (Ref. 35). The  $\phi$  factors used for minimum edge distance were taken as the same as those used for bolted connections.

For arc seam welds, the design shear strength of welds is determined from the same  $\phi$  factor used for arc spot welds. The derivation of the  $\phi$  factor for plate tearing is based on the following statistical data (Ref. 10):

$$\begin{array}{ll} P_m = 1.00; & V_P = 0.10 \\ M_m = 1.10; & V_M = 0.10 \\ F_m = 1.00; & V_F = 0.10 \end{array}$$

For the selected value of  $\phi = 0.60$ , the value of  $\beta = 3.81$ .

For fillet welds, the  $\phi$  factors used for longitudinal loading (Eqs. E2.4-1 and E2.4-2) and transverse loading (Eq. E2.4-3) are based on the statistical data presented in Table CE2 (Ref. 35).

Similar to the arc spot welds, a  $\phi$  factor of 0.60 is used for the design shear strength of welds.

For flare groove welds, the following statistical data were used to determine the  $\phi$  factors:

(a) Transverse Flare Bevel Welds ( $\phi = 0.55$ ,  $\beta = 3.81$ )

$$\begin{array}{ll} P_m = 1.04; & V_P = 0.17 \\ M_m = 1.10; & V_M = 0.10 \\ F_m = 1.00; & V_F = 0.10 \end{array}$$

(b) Longitudinal Flare Bevel Welds ( $\phi = 0.55$ ,  $\beta = 3.56$ )

$$\begin{array}{ll} P_m = 0.97; & V_P = 0.17 \\ M_m = 1.10; & V_M = 0.10 \end{array}$$

$$F_m = 1.00; \quad V_F = 0.10$$

For detailed information, see Ref. 10.

For resistance welds, the nominal shear strength is based on the following equation:

$$R_n = (2.5) \times (\text{allowable shear per spot specified in Section E2.6 of the AISI Specification for allowable stress design})$$

In the above equation, the safety factor is 2.5.

The  $\phi$  factor of 0.65 used in Section E2.6 for the design of resistance welds was determined on the basis of the following statistical data reported in Ref. 10. It gives a  $\beta$  value of 3.71.

$$\begin{array}{ll} P_m = 1.00; & V_P = 0.03 \\ M_m = 1.10; & V_M = 0.10 \\ F_m = 1.00; & V_F = 0.10 \end{array}$$

### E3 Bolted Connections

Section E3 of the LRFD criteria is based on Section E3 of the AISI Specification for allowable stress design. It deals only with the design of bolted connections used for connected parts thinner than 3/16 inch in thickness. For the design of bolted connections using materials equal to or greater than 3/16 inch in thickness, the AISC Specification should be used.

All  $\phi$  factors were computed from the statistical data given in Ref. 10 and  $\beta_0 = 3.5$ . The statistical data used in the study are presented in Table CE3.

The  $\phi$  factors used for the high strength bolts for design shear and tensile strengths are adopted from Ref. 3.

#### E4 Shear Rupture

Section E4 of the LFRD criteria is based on Section E4 of the AISI Specification for allowable stress design. The  $\phi$  factor used in this section is adopted from Ref. 3.

#### E5 Connections to Other Materials

Section E5 of the LFRD criteria is based on Section E5 of the AISI Specification for allowable stress design. The  $\phi$  factor used for bearing is adopted from Ref. 3.

### F. TESTS FOR SPECIAL CASES

#### F1 Tests for Determining Structural Performance

The determination of load-carrying capacity of the tested elements, assemblies, connections, or members is based on the same basis for the LFRD design criteria. The correction factor  $C_p$  is used in the determination of  $\phi$  factor to account for the influence due to the small number of tests (Ref. 36). It should be noted that when the number of tests is large enough, the effect of correction factor is negligible.

For beams having tension flange through-fastened to deck or sheathing and with compression flange laterally unbraced (subject to wind uplift), the calibration is based on a load combination of  $1.17W_n - 0.9D_n$  with  $D_n/W_n = 0.1$  (see Section C3.1.3 of this Commentary for detailed discussion).

The statistical data needed for the determination of resistance factor are listed in Table F1.

#### F2 Tests for Confirming Structural Performance

This section is basically the same as Section F2 of the AISI Specification for allowable stress design.

#### F3 Tests for Determining Mechanical Properties

This section is the same as Section F3 of the AISI Specification for allowable stress design.

Table CE3  
Computed Safety Index  $\beta$  for Bolted Connections

Case	$M_m$	$V_M$	$F_m$	$V_F$	$P_m$	$V_P$	$\phi$	$\beta$
Minimum Spacing and Edge Distance								
1	1.10	0.08	1.00	0.05	1.13	0.12	0.70	3.75
2	1.10	0.08	1.00	0.05	1.18	0.14	0.70	3.84
3	1.10	0.08	1.00	0.05	0.84	0.05	0.60	3.61
4	1.10	0.08	1.00	0.05	0.94	0.09	0.60	3.90
5	1.10	0.08	1.00	0.05	1.06	0.11	0.70	3.62
6	1.10	0.08	1.00	0.05	1.14	0.19	0.60	3.87
Tension Stress on Net Section								
7	1.10	0.08	1.00	0.05	1.14	0.20	0.65	3.53
8	1.10	0.08	1.00	0.05	0.95	0.21	0.55	3.41
9	1.10	0.08	1.00	0.05	1.04	0.14	0.65	3.63
Bearing Stress on Bolted Connections								
10	1.10	0.08	1.00	0.05	1.08	0.23	0.55	3.65
11	1.10	0.08	1.00	0.05	0.97	0.07	0.65	3.80
12	1.10	0.08	1.00	0.05	1.02	0.20	0.60	3.43
13	1.10	0.08	1.00	0.05	1.05	0.13	0.60	4.06
14	1.10	0.08	1.00	0.05	1.01	0.04	0.70	3.71

Table CE3 (Continued)

Computed Safety Index  $\beta$  for Bolted Connections

Case	$M_m$	$V_M$	$F_m$	$V_F$	$P_m$	$V_P$	$\phi$	$\beta$
15	1.10	0.08	1.00	0.05	0.93	0.05	0.65	3.70
Shear Strength on A307 Bolts								
16	1.28	0.08	1.00	0.05	0.68	0.11	0.65	4.73
17	1.13	0.08	1.00	0.05	0.60	0.10	0.65	3.85
18	1.28	0.08	1.00	0.05	0.75	0.10	0.65	5.23
19	1.36	0.08	1.00	0.05	0.63	0.06	0.65	4.49
20	1.13	0.08	1.00	0.05	0.76	0.06	0.65	5.09

Note: Case 1 = Single shear, with washers,  $F_u/F_y \geq 1.15$   
 Case 2 = Double shear, with washers,  $F_u/F_y \geq 1.15$   
 Case 3 = Single shear, with washers,  $F_u/F_y < 1.15$   
 Case 4 = Double shear, with washers,  $F_u/F_y < 1.15$   
 Case 5 = Single shear, without washers,  $F_u/F_y \geq 1.15$   
 Case 6 = Single shear, without washers,  $F_u/F_y < 1.15$   
 Case 7 =  $t < 3/16$  in., double shear, with washers  
 Case 8 =  $t < 3/16$  in., single shear, with washers  
 Case 9 =  $t < 3/16$  in., single shear, without washers  
 Case 10 =  $0.024 \leq t < 3/16$  in., double shear, with washers,  
 $F_u/F_y \geq 1.15$   
 Case 11 =  $0.024 \leq t < 3/16$  in., double shear, with washers,  
 $F_u/F_y < 1.15$   
 Case 12 =  $0.024 \leq t < 3/16$  in., single shear, with washers,  
 $F_u/F_y \geq 1.15$   
 Case 13 =  $0.024 \leq t < 3/16$  in., single shear, with washers,  
 $F_u/F_y < 1.15$   
 Case 14 =  $0.036 \leq t < 3/16$  in., single shear, without washers,  
 $F_u/F_y \geq 1.15$

Table CE3 (Continued)

Computed Safety Index  $\beta$  for Bolted Connections

Case	$M_m$	$V_M$	$F_m$	$V_F$	$P_m$	$V_P$	$\phi$	$\beta$
15	1.10	0.08	1.00	0.05	0.93	0.05	0.65	3.70
Shear Strength on A307 Bolts								
16	1.28	0.08	1.00	0.05	0.68	0.11	0.65	4.73
17	1.13	0.08	1.00	0.05	0.60	0.10	0.65	3.85
18	1.28	0.08	1.00	0.05	0.75	0.10	0.65	5.23
19	1.36	0.08	1.00	0.05	0.63	0.06	0.65	4.49
20	1.13	0.08	1.00	0.05	0.76	0.06	0.65	5.09

Note: Case 1 = Single shear, with washers,  $F_u/F_y \geq 1.15$   
 Case 2 = Double shear, with washers,  $F_u/F_y \geq 1.15$   
 Case 3 = Single shear, with washers,  $F_u/F_y < 1.15$   
 Case 4 = Double shear, with washers,  $F_u/F_y < 1.15$   
 Case 5 = Single shear, without washers,  $F_u/F_y \geq 1.15$   
 Case 6 = Single shear, without washers,  $F_u/F_y < 1.15$   
 Case 7 =  $t < 3/16$  in., double shear, with washers  
 Case 8 =  $t < 3/16$  in., single shear, with washers  
 Case 9 =  $t < 3/16$  in., single shear, without washers  
 Case 10 =  $0.024 \leq t < 3/16$  in., double shear, with washers,  $F_u/F_y \geq 1.15$   
 Case 11 =  $0.024 \leq t < 3/16$  in., double shear, with washers,  $F_u/F_y < 1.15$   
 Case 12 =  $0.024 \leq t < 3/16$  in., single shear, with washers,  $F_u/F_y \geq 1.15$   
 Case 13 =  $0.024 \leq t < 3/16$  in., single shear, with washers,  $F_u/F_y < 1.15$   
 Case 14 =  $0.036 \leq t < 3/16$  in., single shear, without washers,  $F_u/F_y \geq 1.15$



- Case 15 =  $0.036 \leq t < 3/16$  in., double shear, without washers,  
 $F_u/F_y \geq 1.15$
- Case 16 = Double shear, with washers,  $3/8$  in. diameter
- Case 17 = Double shear, with washers,  $3/4$  in. diameter
- Case 18 = Single shear, with washers,  $3/8$  in. diameter
- Case 19 = Single shear, with washers,  $1/2$  in. diameter
- Case 20 = Single shear, with washers,  $3/4$  in. diameter

## REFERENCES

1. Dhalla, A. K., and Winter, G., "Steel Ductility Measurements," Journal of the Structural Division, ASCE, Vol. 100, No. ST2, February 1974.
2. Macadam, J. N., Brockenbrough, R. L., LaBoube, R. A., Pekoz, T., and Schneider, E. J., "Low-Strain-Hardening Ductile-Steel Cold-Formed Members," Proceedings of the Ninth International Specialty Conference on Cold-Formed Steel Structures, University of Missouri-Rolla, Missouri, 1988.
3. American Institute of Steel Construction, "Load and Resistance Factor Design Specification for Structural Steel Buildings," AISC, September 1, 1986.
4. American Iron and Steel Institute, "Specification for the Design of Cold-Formed Steel Structural Members," 1986 Edition.
5. Winter, G., "Commentary on the 1968 Edition of the Specification for the Design of Cold-Formed Structural Members," Cold-Formed Steel Design Manual-Part II, American Iron and Steel Institute, 1970.
6. American Iron and Steel Institute, "Commentary on the August 19, 1986 Edition of the Specification for the Design of Cold-Formed Steel Structural Members," Cold-Formed Steel Design Manual, 1986.
7. Yu, W. W., Cold-Formed Steel Design, John Wiley & Sons, New York, 1985.
8. Pekoz, T., "Development of a Unified Approach to the Design of Cold-Formed Steel Members," Report SG 86-4, American Iron and Steel Institute, May 1986.
9. Ravindra, M. K. and Galambos, T. V., "Load and Resistance Factor Design for Steel," Journal of the Structural Division, ASCE, Vol. 104, No. ST9, September 1978.
10. Hsiao, L. E., Yu, W. W., and Galambos, T. V., "Load and Resistance Factor Design of Cold-Formed Steel: Calibration of the AISI Design Provisions," Ninth Progress Report, Civil Engineering Studies 88-2, Structural Series, Department of Civil Engineering, University of Missouri-Rolla, February 1988.
11. Ellingwood, B., Galambos, T. V., MacGregor, J. G. and Cornell, C. A., "Development of a Probability Based Load Criterion for American National Standard A58: Building Code Requirements for Minimum Design Loads in Buildings and Other Structures," NBS Special publication 577, June 1980.
12. Galambos, T. V., Ellingwood, B., MacGregor, J. G. and Cornell, C. A., "Probability Based Load Criteria: Assessment of Current Design Practice," Journal of the Structural Division, ASCE, Vol. 108, No. ST5, May 1982.

13. Rang, T. N., Galambos, T. V. and Yu, W. W., "Load and Resistance Factor Design of Cold-Formed Steel: Study of Design Formats and Safety Index Combined with Calibration of the AISI Formulas for Cold Work and Effective Design Width," First Progress Report, Civil Engineering Studies 79-1, Structural Series, Department of Civil Engineering, University of Missouri-Rolla, January 1979.
14. Rang, T. N., Galambos, T. V. and Yu, W. W., "Load and Resistance Factor Design of Cold-Formed Steel: Statistical Analysis of Mechanical Properties and Thickness of Material Combined with Calibration of the AISI Design Provisions on Unstiffened Compression Elements and Connections," Second Progress Report, Civil Engineering Studies 79-2, Structural Series, Department of Civil Engineering, University of Missouri-Rolla, January 1979.
15. Rang, T. N., Galambos, T. V. and Yu, W. W., "Load and Resistance Factor Design of Cold-Formed Steel: Calibration of the Design Provisions on Connections and Axially Loaded Compression Members," Third Progress Report, Civil Engineering Studies 79-3, Structural Series, Department of Civil Engineering, University of Missouri-Rolla, January 1979.
16. Rang, T. N., Galambos, T. V. and Yu, W. W., "Load and Resistance Factor Design of Cold-Formed Steel: Calibration of the Design Provisions on Laterally Unbraced Beams and Beam-Columns," Fourth Progress Report, Civil Engineering Studies 79-4, Structural Series, Department of Civil Engineering, University of Missouri-Rolla, January 1979.
17. Supornsilaphachai, B., Galambos, T. V. and Yu, W. W., "Load and Resistance Factor Design of Cold-Formed Steel: Calibration of the Design Provisions on Beam Webs," Fifth Progress Report, Civil Engineering studies 79-5, Structural Series, Department of Civil Engineering, University of Missouri-Rolla, September 1979.
18. Ellingwood, B., MacGregor, J. G., Galambos, T. V. and Cornell, C. A., "Probability Based Load Criteria: Load Factors and Load Combinations," Journal of the Structural Division, ASCE, Vol. 108, No. ST5, May 1982.
19. American National Standards Institute, "Minimum Design Loads for Buildings and Other Structures," ANSI A58.1-1982.
20. Pekoz, T., and Soroushian, D., "Behavior of C- and Z- Purlins Under Wind Uplift," Proceedings of the Sixth International Specialty Conference on Cold-Formed Steel Structures, University of Missouri-Rolla, Missouri, 1982.
21. LaBoube, R. A., "Laterally Unsupported Purlins Subjected to Uplift," Final Report, Metal Building Manufacturers Association, December 1983.
22. Haussler, R. W., and Pahers, R. F., "Connection Strength in Thin Metal Roof Structures," Proceedings of the Second International Specialty Conference on Cold-Formed Steel Structures, University of Missouri-Rolla, Missouri, 1973.

23. LaBoube, R. A., Golovin, M., Montague, D. J., Perry, D. C., and Wilson, L. L., "Behavior of Continuous Span Purlin Systems," Proceedings of the Ninth International Specialty Conference on Cold-Formed Steel Structures, University of Missouri-Rolla, Missouri, 1988.
24. Haussler, R. W., "Theory of Cold-Formed Steel Purlin/Girt Flexure," Proceedings of the Ninth International Specialty Conference on Cold-Formed Steel Structures, University of Missouri-Rolla, Missouri, 1988.
25. LaBoube, R. A., "Roof Panel to Purlin Connection: Rotational Restraint Factor," Proceedings of the IABSE Colloquim on Thin-Walled Metal Structures in Buildings, Stockholm, Sweden, June 1986.
26. Pekoz, T. B. and Winter, G., "Torsional-Flexural Buckling of Thin-Walled Sections Under Eccentric Load," Cornell University, Report No. 329, April 1967.
27. Thomasson, P. O., "Thin-Walled C-Shaped Panel in Axial Compression," Document D1, Swedish Council for Building Research, Stockholm, Sweden, 1978.
28. Loughlan, J., "Mode Interaction in Lipped Channel Columns Under Concentric and Eccentric Loading," Ph.D. Thesis, Department of Mechanics of Materials, University of Strathclyde, Glasgow, 1979.
29. Mulligan, G. D. and Pekoz, T., "The Influence of Local Buckling on the Structural Behavior of Singly Symmetric Cold Formed Steel Columns," Department of Structural Engineering Report, Cornell University, 1983.
30. Loh, T. S. and Pekoz, T., "Combined Axial Load and Bending in Cold-Formed Steel Members," Department of Structural Engineering Report, Cornell University, 1985.
31. Murray, T. M., and Elhouar, S., "Stability Requirements of Z-Purlin Supported Conventional Metal Building Roof Systems," Annual Technical Session Proceedings, Structural Stability Research Council, 1985.
32. Simaan, A., Winter, G., and Pekoz, T., "Buckling of Diaphragm-Braced Columns of Unsymmetrical Sections and Applications to Wall Studs Design," Cornell University, Report No. 353, August 1973.
33. Simaan, A., and Pekoz, T., "Diaphragm-Braced Members and Design of Wall Studs," Proceedings of the American Society of Civil Engineers, Vol. 102, ST1, January 1976.
34. Pekoz, T. and McGuire, W., "Welding of Sheet Steel," Report SG 79-2, Committee of Sheet Steel Producers, American Iron and Steel Institute, January 1979.
35. Supornsilaphachai, B., "Load and Resistance Factor Design of Cold-Formed Steel Structural Members," Thesis presented to the University of Missouri-Rolla, Missouri, in partial fulfillment of the requirements for the degree of Doctor of Philosophy, 1980.

36. Pekoz, T., and Hall, W. B., "Probabilistic Evaluation of Test Results," Proceedings of the Ninth International Specialty Conference on Cold-Formed Steel Structures, University of Missouri-Rolla, Missouri, 1988.
37. LaBoube, R. A., and Thompson, M. B., "Static Load Tests of Braced Purlins Subjected to Uplift Load," Final Report, Project No. 7485-G, Midwest Research Institute, Kansas City, Missouri, 1982.
38. Pekoz, T. B., and Soroushian, P., "Behavior of C- and Z-Purlins Under Uplift," Report No. 81-2, Department of Structural Engineering, Cornell University, Ithaca, NY, 1981.