

01 Nov 1990

## Design of automotive structural components using high strength sheet steels structural strength of cold-formed steel members under dynamic loads

Chi-Ling Pan

Wei-Wen Yu

Missouri University of Science and Technology, [wwy4@mst.edu](mailto:wwy4@mst.edu)

Follow this and additional works at: <https://scholarsmine.mst.edu/ccfss-library>



Part of the [Structural Engineering Commons](#)

---

### Recommended Citation

Pan, Chi-Ling and Yu, Wei-Wen, "Design of automotive structural components using high strength sheet steels structural strength of cold-formed steel members under dynamic loads" (1990). *CCFSS Library (1939 - present)*. 93.

<https://scholarsmine.mst.edu/ccfss-library/93>

This Technical Report is brought to you for free and open access by Scholars' Mine. It has been accepted for inclusion in CCFSS Library (1939 - present) by an authorized administrator of Scholars' Mine. This work is protected by U. S. Copyright Law. Unauthorized use including reproduction for redistribution requires the permission of the copyright holder. For more information, please contact [scholarsmine@mst.edu](mailto:scholarsmine@mst.edu).

Civil Engineering Study 90-3  
Structural Series

Fifteenth Progress Report

DESIGN OF AUTOMOTIVE STRUCTURAL COMPONENTS  
USING HIGH STRENGTH SHEET STEELS

STRUCTURAL STRENGTH OF COLD-FORMED STEEL MEMBERS UNDER DYNAMIC LOADS

by

Chi-Ling Pan  
Research Assistant

Wei-Wen Yu  
Project Director

A Research Project Sponsored by the American Iron and Steel Institute

November 1990

Department of Civil Engineering  
University of Missouri-Rolla  
Rolla, Missouri

## TABLE OF CONTENTS

	Page
LIST OF TABLES .....	iv
LIST OF FIGURES .....	x
I. INTRODUCTION.....	1
II. EXPERIMENTAL INVESTIGATION.....	3
A. GENERAL.....	3
B. MATERIAL PROPERTIES.....	4
C. STUB COLUMN TESTS FOR STIFFENED ELEMENTS.....	5
1. Specimens.....	5
2. Strain Measurements.....	6
3. Instrumentation and Test Procedure.....	7
4. Test Results.....	8
C. STUB COLUMN TESTS FOR I-SHAPED SECTIONS HAVING UNSTIFFENED ELEMENTS.....	9
1. Specimens.....	9
2. Strain Measurements.....	10
3. Instrumentation and Test Procedure.....	11
4. Test Results.....	11
III. EVALUATION OF EXPERIMENTAL DATA.....	13
A. GENERAL.....	13

## TABLE OF CONTENTS (Cont.)

	Page
B. STUB COLUMN TESTS FOR THE STUDY OF STIFFENED ELEMENTS.	13
1. Critical Buckling Load.....	14
2. Ultimate Axial Load.....	16
C. STUB COLUMN TESTS FOR THE STUDY OF UNSTIFFENED ELEMENTS	19
1. Critical Buckling Load.....	20
2. Ultimate Axial Load.....	21
IV. CONCLUSIONS .....	24
ACKNOWLEDGMENTS .....	26
REFERENCES .....	27
APPENDIX .....	96
A. EFFECT OF COLD WORK ON THE AXIAL STRENGTH OF STUB COLUMNS ..	96
B. NOTATION .....	107

## LIST OF TABLES

Table	Page
2.1 Designation of Test Specimens Used in This Study.....	28
2.2 Number of Performed Stub Column Tests, Box Sections Having Stiffened Elements (35XF Sheet Steel).....	29
2.3 Number of Performed Stub Column Tests, Box Sections Having Stiffened Elements (50XF Sheet Steel).....	30
2.4 Number of Performed Stub Column Tests, I-sections Having Unstiffened Elements (35XF Sheet Steel).....	31
2.5 Number of Performed Stub Column Tests, I-sections Having Unstiffened Elements (50XF Sheet Steel).....	32
2.6 Average Mechanical Properties of 35XF Sheet Steel Used in the Experimental Study Under Different Strain Rates.....	33
2.7 Average Mechanical Properties of 50XF Sheet Steel Used in the Experimental Study Under Different Strain Rates.....	34
2.8 Dimensions of Stub Columns with Stiffened Flanges Fabricated from 35XF Sheet Steel.....	35
2.9 Dimensions of Stub Columns with Stiffened Flanges Fabricated from 50XF Sheet Steel.....	36
2.10 Dimensions of Stub Columns with Unstiffened Flanges Fabricated from 35XF Sheet Steel.....	37
2.11 Dimensions of Stub Columns with Unstiffened Flanges Fabricated from 50XF Sheet Steel.....	38

## LIST OF TABLES (cont.)

Table	Page
3.1 Comparison of Computed and Tested Critical Buckling Loads, Stub Columns with Stiffened Flanges (Based on $k=4.0$ ) (35XF Sheet Steel).....	39
3.2 Comparison of Computed and Tested Critical Buckling Loads, Stub Columns with Stiffened Flanges (Based on $k=4.0$ ) (50XF Sheet Steel).....	40
3.3(a) Comparison of Computed and Tested Failure Loads Based on the Effective Width Formulas in the 1986 AISI Automotive Steel Design Manual for Stub Columns with Stiffened Flanges (Based on Static Yield Stress) (35XF Sheet Steel).....	41
3.3(b) Comparison of Computed and Tested Failure Loads Based on the Effective Width Formulas in the 1986 AISI Automotive Steel Design Manual for Stub Columns with Stiffened Flanges (Based on Dynamic Yield Stress) (35XF Sheet Steel).....	42
3.4(a) Comparison of Computed and Tested Failure Loads Based on the Effective Width Formulas in the 1986 AISI Automotive Steel Design Manual for Stub Columns with Stiffened Flanges (Based on Static Yield Stress) (50XF Sheet Steel).....	43

## LIST OF TABLES (cont.)

Table	Page
3.4(b) Comparison of Computed and Tested Failure Loads Based on the Effective Width Formulas in the 1986 AISI Automotive Steel Design Manual for Stub Columns with Stiffened Flanges (Based on Dynamic Yield Stress) (50XF Sheet Steel).....	44
3.5 Average Tested Failure Loads for Stub Column Specimens with Stiffened Elements (35XF Sheet Steel).....	45
3.6 Average Tested Failure Loads for Stub Column Specimens with Stiffened Elements (50XF Sheet Steel).....	45
3.7 Comparison of Computed and Tested Critical Buckling Loads, Stub Columns with Unstiffened Flanges (Based on $k=0.43$ ) (35XF Sheet Steel).....	46
3.8 Comparison of Computed and Tested Critical Buckling Loads, Stub Columns with Unstiffened Flanges (Based on $k=0.43$ ) (50XF Sheet Steel).....	47
3.9(a) Comparison of Computed and Tested Failure Loads Based on the Effective Width Formulas in the 1986 AISI Automotive Steel Design Manual for Stub Columns with Unstiffened Flanges (Based on Static Yield Stress) (35XF Sheet Steel).....	48

## LIST OF TABLES (cont.)

Table	Page
3.9(b) Comparison of Computed and Tested Failure Loads Based on the Effective Width Formulas in the 1986 AISI Automotive Steel Design Manual for Stub Columns with Unstiffened Flanges (Based on Dynamic Yield Stress) (35XF Sheet Steel).....	49
3.10(a) Comparison of Computed and Tested Failure Loads Based on the Effective Width Formulas in the 1986 AISI Automotive Steel Design Manual for Stub Columns with Unstiffened Flanges (Based on Static Yield Stress) (50XF Sheet Steel).....	50
3.10(b) Comparison of Computed and Tested Failure Loads Based on the Effective Width Formulas in the 1986 AISI Automotive Steel Design Manual for Stub Columns with Unstiffened Flanges (Based on Dynamic Yield Stress) (50XF Sheet Steel).....	51
3.11 Average Tested Failure Loads for Stub Column Specimens with Unstiffened Elements (35XF Sheet Steel).....	52
3.12 Average Tested Failure Loads for Stub Column Specimens with Unstiffened Elements (50XF Sheet Steel).....	52



## LIST OF TABLES (cont.)

Table	Page
3.3(a)-A Comparison of Computed and Tested Failure Loads Based on the Effective Width Formulas in the 1986 AISI Automotive Steel Design Manual for Stub Columns with Stiffened Flanges (Based on Static Tensile Stress and Considering Cold-Work of Forming) (35XF Sheet Steel) .....	99
3.3(b)-A Comparison of Computed and Tested Failure Loads Based on the Effective Width Formulas in the 1986 AISI Automotive Steel Design Manual for Stub Columns with Stiffened Flanges (Based on Dynamic Tensile Stress and Considering Cold-Work of Forming) (35XF Sheet Steel) .....	100
3.4(a)-A Comparison of Computed and Tested Failure Loads Based on the Effective Width Formulas in the 1986 AISI Automotive Steel Design Manual for Stub Columns with Stiffened Flanges (Based on Static Tensile Stress and Considering Cold-Work of Forming) (50XF Sheet Steel) .....	101
3.4(b)-A Comparison of Computed and Tested Failure Loads Based on the Effective Width Formulas in the 1986 AISI Automotive Steel Design Manual for Stub Columns with Stiffened Flanges (Based on Dynamic Tensile Stress and Considering Cold-Work of Forming) (50XF Sheet Steel) .....	102

## LIST OF TABLES (cont.)

Table	Page
3.9(a)-A Comparison of Computed and Tested Failure Loads Based on the Effective Width Formulas in the 1986 AISI Automotive Steel Design Manual for Stub Columns with Unstiffened Flanges (Based on Static Tensile Stress and Considering Cold-Work of Forming) (35XF Sheet Steel) .....	103
3.9(b)-A Comparison of Computed and Tested Failure Loads Based on the Effective Width Formulas in the 1986 AISI Automotive Steel Design Manual for Stub Columns with Unstiffened Flanges (Based on Dynamic Tensile Stress and Considering Cold-Work of Forming) (35XF Sheet Steel) .....	104
3.10(a)-A Comparison of Computed and Tested Failure Loads Based on the Effective Width Formulas in the 1986 AISI Automotive Steel Design Manual for Stub Columns with Unstiffened Flanges (Based on Static Tensile Stress and Considering Cold-Work of Forming) (50XF Sheet Steel) .....	105
3.10(b)-A Comparison of Computed and Tested Failure Loads Based on the Effective Width Formulas in the 1986 AISI Automotive Steel Design Manual for Stub Columns with Unstiffened Flanges (Based on Dynamic Tensile Stress and Considering Cold-Work of Forming) (50XF Sheet Steel) .....	106

## LIST OF FIGURES

Figure	Page
2.1 Configuration of Test Specimens for Members Having Stiffened Compression Flanges.....	53
2.1 Configuration of Test Specimens for Members Having Unstiffened Compression Flanges.....	53
2.3 Stress-Strain Curves for 35XF Sheet Steel Tested Under Different Strain Rates (Longitudinal Tension).....	54
2.4 Stress-Strain Curves for 35XF Sheet Steel Tested Under Different Strain Rates (Longitudinal Compression).....	55
2.5 Stress-Strain Curves for 50XF Sheet Steel Tested Under Different Strain Rates (Longitudinal Tension).....	56
2.6 Stress-Strain Curves for 50XF Sheet Steel Tested Under Different Strain Rates (Longitudinal Compression).....	57
2.7 Compressive Yield Stress vs. Logarithmic Strain-Rate Curve for 35XF Steel (Longitudinal Compression).....	58
2.8 Compressive Yield Stress vs. Logarithmic Strain-Rate Curve for 50XF Steel (Longitudinal Compression).....	59
2.9 Cross Section of Box-Shaped Stub Columns Used for the Study of Stiffened Elements.....	60
2.10 Locations of Strain Gages at Midheight of Box-Shaped Stub Columns.....	60
2.11 Locations of Strain Gages along the Specimen Length for Box-Shaped Stub Columns Having Large w/t Ratios.....	61

## LIST OF FIGURES (Cont.)

Figure	Page
2.12 MTS 880 Material Test System and CAMAC Data Acquisition Used for Stub Column Tests.....	62
2.13 Load-Strain Curves of Strain Gages # 1 and 2 Installed at the Center of Stiffened Elements (Spec. 1A1AX).....	63
2.14 Load-Strain Curves of Strain Gages # 9 and 10 Installed at the Center of Stiffened Elements (Spec. 1B2BX).....	64
2.15 Load-Strain Curves of Strain Gages # 9 and 10 Installed at the Center of Stiffened Elements (Spec. 1C3BX).....	65
2.16 Typical Failure of Stub Columns with Large w/t ratios.....	66
2.17 Load-Displacement Curves for Stub Column Specimens (35XF) 1A1A, 1A2A, and 1A3A.....	67
2.18 Load-Displacement Curves for Stub Column Specimens (35XF) 1B1A, 1B2A, and 1B3A.....	68
2.19 Load-Displacement Curves for Stub Column Specimens (35XF) 1C1A, 1C2A, and 1C3A.....	69
2.20 Load-Displacement Curves for Stub Column Specimens (35XF) 1D1A, 1D2A, and 1D3A.....	70
2.21 Load-Displacement Curves for Stub Column Specimens (50XF) 1A1BX, 1A2BX, and 1A3AX.....	71
2.22 Load-Displacement Curves for Stub Column Specimens (50XF) 1B1AX, 1B2AX, and 1B3AX.....	72

## LIST OF FIGURES (Cont.)

Figure	Page
2.23 Load-Displacement Curves for Stub Column Specimens (50XF) 1C1AX, 1C2BX, and 1C3BX.....	73
2.24 Load-Displacement Curves for Stub Column Specimens (50XF) 1D1AX, 1D2AX, and 1D3AX.....	74
2.25 Typical Plot of Strain-Time Relationship for Stub Columns with Stiffened Elements Under Intermediate Strain Rate (Spec. 1B2BX).....	75
2.26 Cross Section of I-shaped Stub Columns Used for the Study of Unstiffened Elements.....	76
2.27 Locations of Strain Gages at Midheight of I-Shaped Stub Columns.....	76
2.28 Load-Strain Curves of Strain Gages # 1 and 2 Installed at the Tips of Unstiffened Elements (Spec. 2C2BX).....	77
2.29 Typical Failure of Stub Columns with Large w/t Ratios.....	78
2.30 Load-Displacement Curves for Stub Column Specimens (35XF) 2A1A, 2A2A, and 2A3A.....	79
2.31 Load-Displacement Curves for Stub Column Specimens (35XF) 2B1A, 2B2A, and 2B3A.....	80
2.32 Load-Displacement Curves for Stub Column Specimens (35XF) 2C1A, 2C2A, and 2C3A.....	81
2.33 Load-Displacement Curves for Stub Column Specimens (35XF) 2D1A, 2D2A, and 2D3A.....	82

## LIST OF FIGURES (Cont.)

Figure	Page
2.34 Load-Displacement Curves for Stub Column Specimens (50XF) 2A1AX, 2A2AX, and 2A3AX.....	83
2.35 Load-Displacement Curves for Stub Column Specimens (50XF) 2B1AX, 2B2AX, and 2B3AX.....	84
2.36 Load-Displacement Curves for Stub Column Specimens (50XF) 2C1AX, 2C2AX, and 2C3AX.....	85
2.37 Load-Displacement Curves for Stub Column Specimens (50XF) 2D1AX, 2D2AX, and 2D3AX.....	86
2.38 Typical Plot of Strain-Time Relationship for Stub Columns with Stiffened Elements (Spec. 2A3AX).....	87
3.1 Ratios of Tested Ultimate Loads to Computed Ultimate Loads (Based on Static Yield Stress) vs. Logarithmic Strain Rate for Box-Shaped Stub Columns (35XF Sheet Steel).....	88
3.2 Ratios of Tested Ultimate Loads to Computed Ultimate Loads (Based on Dynamic Yield Stresses) vs. Logarithmic Strain Rate for Box-Shaped Stub Columns (35XF Sheet Steel).....	89
3.3 Ratios of Tested Ultimate Loads to Computed Ultimate Loads (Based on Static Yield Stress) vs. Logarithmic Strain Rate for Box-Shaped Stub Columns (50XF Sheet Steel).....	90
3.4 Ratios of Tested Ultimate Loads to Computed Ultimate Loads (Based on Dynamic Yield Stresses) vs. Logarithmic Strain Rate for Box-Shaped Stub Columns (50XF Sheet Steel).....	91

## LIST OF FIGURES (Cont.)

Figure	Page
3.5 Ratios of Tested Ultimate Loads to Computed Ultimate Loads (Based on Static Yield Stress) vs. Logarithmic Strain Rate for I-Shaped Stub Columns (35XF Sheet Steel).....	92
3.6 Ratios of Tested Ultimate Loads to Computed Ultimate Loads (Based on Dynamic Yield Stresses) vs. Logarithmic Strain Rate for I-Shaped Stub Columns (35XF Sheet Steel).....	93
3.7 Ratios of Tested Ultimate Loads to Computed Ultimate Loads (Based on Static Yield Stress) vs. Logarithmic Strain Rate for I-Shaped Stub Columns (50XF Sheet Steel).....	94
3.8 Ratios of Tested Ultimate Loads to Computed Ultimate Loads (Based on Dynamic Yield Stresses) vs. Logarithmic Strain Rate for I-Shaped Stub Columns (50XF Sheet Steel).....	95

## I. INTRODUCTION

During recent years, more economic and lighter vehicles have been produced by automotive manufacturers because of the high cost of fuel. High strength sheet steels have been favorably used to accomplish the construction of such automobiles. One source of the design information for using sheet steels is provided in the AISI Automotive Steel Design Manual<sup>1</sup>.

In view of the fact that material properties and stress-strain relationships of sheet steels can be influenced by the strain rate, the material properties of three different sheet steels (35XF, 50XF, and 100XF) have been studied at University of Missouri-Rolla. This study involved primarily with the experimental determination of the mechanical properties in tension and compression under different strain rates from  $10^{-4}$  to 1.0 in./in./sec.. The yield strengths of three types of sheet steels ranged from 35 to 100 ksi. The test results obtained from this study were presented in the Eleventh<sup>2</sup> and Twelfth<sup>3</sup> Progress Reports. Subsequently, the same results were used to evaluate the member strengths of stub columns and flexural members.

During the period from August 1989 through April 1990, the structural behavior and strength of steel members having both unstiffened and stiffened elements were studied experimentally for stub columns and beams fabricated from 35XF sheet steel. The test results were presented in the Thirteenth<sup>4</sup> and Fourteenth<sup>5</sup> Progress Reports.



In the Thirteenth Progress Report, the w/t ratios for stub columns with the unstiffened elements ranged from 8.93 to 20.97 and the w/t ratios for stub columns with stiffened elements ranged from 26.92 to 53.39. The strain rates for stub column tests varied from  $10^{-4}$  to  $10^{-1}$  in./in./sec.. In order to study the behavior of cold-formed steel members with large w/t ratios, I-shaped sections having unstiffened elements with w/t ratios of about 44 and box-shaped sections having stiffened elements with w/t ratios of about 100 were fabricated from 35XF sheet steel and tested in August 1990. The test results and the evaluation are presented in Chapter II and Chapter III of this report, respectively.

In addition, 48 stub columns have also been fabricated from 50XF sheel steel for static and dynamic tests. These specimens were tested during the period from August through October 1990. Because the current effective design width formulas were originally derived from the test results obtained from the static tests, the main purpose of this study was to determine the validity of the current formulas for structural members subjected to dynamic loads.

In Chapter II of this report, the experimental investigation of stub columns is discussed in detail. The test data are evaluated in Chapter III. In Chapter IV, the present and future research work are summarized and the conclusions are drawn on the basis of the available test results.

## II EXPERIMENTAL INVESTIGATION

### A. GENERAL

As pointed out in Chapter I, the current design criteria for effective design width being used in the AISI Automotive Steel Design Manual<sup>1</sup> for the design of cold-formed steel members are based on the test results under static loading condition. The objective of this investigation was to study the validity of these effective design width formulas for members subjected to dynamic loads.

All tests were performed in the MTS 880 Test System located in the Engineering Research Laboratory at the University of Missouri-Rolla. The materials used in this phase of study are 35XF and 50XF sheet steels with nominal yield strengths equal to approximately 35 ksi and 50 ksi, respectively. Since May 1989, a total of 24 box-shaped stub columns were fabricated from 35XF sheet steel and 22 box-shaped stub columns were fabricated from 50XF sheet steel. These specimens were tested to study the strength of stiffened elements. For the strength of unstiffened elements, 25 I-shaped stub columns were fabricated from 35XF sheet steel and 26 I-shaped stub columns were fabricated from 50XF sheet steel. These specimens were cold-formed to shape by Butler Manufacturing Company in Grandview, Missouri and Holloway Machine Company in Springfield, Missouri. The configurations of stub column specimens having stiffened and unstiffened elements are shown in Figures 2.1 and 2.2, respectively. The designation of test specimens is presented in Table 2.1. Two groups of test specimens were used for each sheet steel, i.e. 35XF or 50XF.

Group I is for box-shaped stub columns and Group II is for I-shaped stub columns. In each group, four cases of w/t ratios were studied. Cases A, B, C, and D represent the small, medium, large, and extra large w/t ratios, respectively. Tables 2.2 to 2.5 show the specimen number, test speed, strain rate, w/t ratio, and the slenderness ratio, L/r, of each individual test specimen. A total of 97 stub column specimens were tested and are discussed in this study.

#### B. MATERIAL PROPERTIES.

The mechanical properties of 35XF and 50XF sheet steels were presented in the Eleventh and Twelfth Progress Reports. The average values of mechanical properties tested under different strain rates for 35XF and 50XF sheet steels include yield stress ( $F_y$ ) in tension and compression, proportional limit ( $F_{pr}$ ), tensile strength ( $F_u$ ), and elongation in 2-in. gage length as given in Tables 2.6 and 2.7. To illustrate the effect of strain rate on the mechanical properties, Figures 2.3 and 2.4 show the typical stress-strain relationships for the 35XF sheet steel subjected to longitudinal tension or compression with different strain rates of 0.0001, 0.01, and 1.0 in./in./sec.. The typical stress-strain relationships for the 50XF sheet steel are shown in Figures 2.5 and 2.6. The thicknesses of 35XF and 50XF sheet steels are 0.085 in. and 0.077 in., respectively.

From Figures 2.3 to 2.6, it can be seen that the effect of strain rate on material properties varies for each material. The empirical equations derived on the basis of the material test results are shown in

Figures 2.7 and 2.8, which are used to predict longitudinal compressive yield stress.

### C. STUB COLUMN TESTS FOR STIFFENED ELEMENTS

1. Specimens. Stub column tests were used to study the local and postbuckling strengths of compression elements. For the design of cold-formed steel members, the effective design width formula has been employed for the determination of the structural strength. The length of stub column specimens has been designed long enough (more than 3 times the largest dimension of the cross section) to develop the buckling wave and short enough (less than 20 times the least radius of gyration) to prevent overall buckling of the entire member as recommended in Reference 6 and Part VII of the 1986 AISI Cold-Formed Steel Design Manual<sup>7</sup>. In order to investigate the behavior and strength of stiffened compression elements, the webs and unstiffened flanges of all hat sections were designed to be fully effective. Tables 2.8 and 2.9 give the lengths and dimensions of stub column test specimens fabricated from 35XF and 50XF sheet steels, respectively.

Prior to April 1990, a total of 18 stub column specimens fabricated from 35XF sheet steel have been tested and reported in the Thirteenth Progress Report. These specimens have stiffened elements with  $w/t$  ratios ranging from 26.92 to 53.39. Since May 1990, six additional stub column specimens were fabricated from 35XF sheet steel and tested to study the strength of stiffened elements with the  $w/t$  value of 100.62. In addition, a total of 22 stub column test specimens were fabricated from 50XF sheet

steel and tested to study the local buckling and postbuckling strengths of stiffened elements with w/t ratios ranging from 22.89 to 98.21. Due to lack of 50XF sheet steel material, only four stub column specimens were fabricated and tested for box sections having stiffened flanges with a w/t ratio of approximately 98.0. In this study, strain rates for the tests ranged from  $10^{-4}$  to  $10^{-1}$  in./in./sec..

As shown in Figure 2.9, two hat sections were assembled by connecting two unstiffened flanges to form a box-shaped stub column. To avoid the failure of bolts, 1/4"-diameter, Grade 8 high strength bolts were used to fabricate the test specimens. The spacing between bolts was chosen to satisfy the requirements of the AISI Specification.<sup>7</sup> To ensure a better contact between the ends of test specimens and compression platens of the test machine, all specimens were milled in the machine shop at University of Missouri-Rolla to make both ends of stub column flat and parallel.

2. Strain Measurements. There are several reasons for mounting strain gages on the test specimens : (1) to ensure the alignment of stub-column specimens, (2) to detect the local buckling load, (3) to determine the stress at the location of strain gage, and (4) to determine the strain rate used in the test. For specimens with small w/t ratios (cases A and B of Group I for using 35XF and 50XF sheet steels), eight foil strain gages were mounted at midheight of stub column specimens. For the stub columns with large w/t ratios (cases C and D of Group I for using 35XF and 50XF sheet steels), additional eight strain gages were

mounted above and below the midheight of stub column at the location equal to one-half of the overall width of the stiffened elements. The arrangements of strain gages are shown in Figures 2.10 and 2.11.

All strain gages were used to check the alignment. The load-strain diagrams obtained from paired strain gages (No. 1-2, 5-6, and 9 through 16) were used to determine the local buckling load by means of the modified strain reversal method, which is discussed in Reference 8. For some specimens, additional paired strain gages were placed on the edges of stiffened elements of stub columns to measure the maximum edge strains.

3. Instrumentation and Test Procedure. All stub column tests were performed by using a 880 Material Test System with a capacity of 110 kips shown in Figure 2.12. For all tests, the maximum load range of 100 kips and the maximum stroke ranges of 1 or 0.5 inches were selected for the function generator of the test machine. The ramp time was programmed to have a constant speed, which was calculated by the product of the selected strain rate and the overall length of the specimen. The CAMAC Data Acquisition System (Figure 2.12) was used to record all the data during tests. After the data has been acquired, it was downloaded to the Data General Mini Computer for analysis purpose.

In order to obtain good test results, a small amount of preload was applied to the stub column prior to testing for the purpose of checking the alignment of specimens. If necessary, thin aluminum foils were placed

at the end of the specimen in the regions of low strain until the load is uniformly distributed over the whole cross section.

4. Test Results. It is well known that the local buckling stress depends on the width-to-thickness ratio of the stiffened compression element. As shown in Figure 2.13, no local buckling occurred in the specimens with small w/t ratios (case A of Group I for using both 35XF and 50XF sheet steels). For specimens with medium w/t ratios, (i.e., case B of Group I for using 35XF and 50XF sheet steels), the stiffened flanges normally buckled in the inelastic range as shown in Figure 2.14. The local buckling occurred in the elastic range for the specimens having large w/t ratios (cases C and D of Group I for using 35XF and 50XF sheet steels). When local buckling occurred in the test specimens, the stresses in the compression flanges redistributed over the cross section until the edge stress reached to the maximum value. Typical load-strain relationship for the specimens with large w/t ratios is shown in Figure 2.15.

The location of local buckling for the box-shaped stub columns with small or medium w/t ratios was found to be either at the end or at midheight or both. However, the sections with large w/t ratios failed locally at or near the midheight of specimens regardless of the strain rate for most cases. Figure 2.16 is an example of locally buckled test specimen with large w/t ratio of 98.07.

Figures 2.17 to 2.20 show typical load-displacement diagrams for box-shaped stub columns fabricated from 35XF sheet steel and tested under different strain rates. The average  $w/t$  ratio of stiffened elements and the strain rates used in the tests are indicated in each figure. Similarly, Figures 2.21 to 2.24 show four typical load-displacement curves for box-shaped stub columns fabricated from 50XF sheet steel. Although a constant speed was applied to the test specimens during the test, however, the strain rate could not be retained constant after the ultimate load reached in the specimen. Therefore, the value of strain rate was defined as the slope of the strain-time relationship before the attainment of the ultimate load. A typical strain-time diagram for an intermediate strain rate is shown in Figure 2.25. The tested ultimate loads are presented in Tables 2.8 and 2.9 for the box-shaped stub columns fabricated from 35XF and 50XF sheet steels, respectively.

#### D. STUB COLUMN TESTS FOR UNSTIFFENED ELEMENTS

1. Specimens. In this phase of experimental investigation, I-shaped stub columns made of 35XF and 50XF sheet steels were tested to study the local buckling and postbuckling strength of unstiffened elements affected by strain rate. A total of 19 stub column test specimens fabricated from 35XF sheet steel have been tested and reported in the Thirteenth Progress Report. These specimens have unstiffened elements with  $w/t$  ratios ranging from 8.93 to 20.97. Six additional stub column specimens fabricated from 35XF sheet steel were tested since May 1990 to study the strength of unstiffened elements with the  $w/t$  value of 44.57. In addition, a total of 26 stub column test specimens fabricated from 50XF sheet steel were



tested to study the local buckling and postbuckling strength of unstiffened elements with w/t ratios ranging from 8.29 to 35.37. The strain rates for all tests ranged from  $10^{-5}$  to  $10^{-1}$  in./in./sec..

In order to investigate the behavior and strength of unstiffened compression elements, the web of all channel sections has been designed to be fully effective, while the length of all members has been designed to be longer than three times the largest dimension of the cross section and less than 20 times the least radius of gyration as recommended in Reference 6 and Part VII of the 1986 AISI Cold Formed Steel Design Manual<sup>7</sup>.

As shown in Figure 2.26, PC-7 epoxy adhesive material was used to assemble two channel sections back to back to form an I-shaped stub column specimen. Before two sections were bonded together, the surfaces of webs were paper sanded and cleaned with methyl alcohol and water. In order to maintain a uniform epoxy thickness, 0.002"-diameter wires were placed between the webs of two channel sections. Two channel sections were clamped together by using C-clamps. The test specimens were cured in the room-temperature condition and C-clamps were released after 24 hours. Same as the box-shaped specimens, all I-shaped specimens were milled to make both ends of stub column flat and parallel.

2. Strain Measurements. Fourteen foil strain gages were mounted at midheight of stub column specimens. Four paired strain gages (No. 1-2, 5-6, 7-8, and 11-12) were placed along the tips of unstiffened flanges

for the purpose of determining the local buckling load. By using the modified strain reversal method, the critical local buckling load was obtained from load-strain relationships of these paired strain gages. In addition, four strain gages (No. 3, 4, 9, and 10) were placed along the supported edges of unstiffened flanges to measure the maximum edge strains. The paired strain gages (No. 13 and 14) were placed along the centerline of the web to monitor any premature failure of the web. All strain gages on the specimen were used to check the alignment. Figure 2.27 shows the arrangement of strain gages.

3. Instrumentation and Test Procedure. To obtain the necessary background information, all specimens were loaded to failure. The instrumentation and test procedure used for this phase of study are the same as those used in the tests of stub columns for the study of stiffened elements. For all tests, the maximum load ranges of 50 or 100 kips and the maximum stroke ranges of 0.5 or 1.0 inches were selected in the function generator of the test machine. During the test, the applied loads, the actuator displacement, the strains of fourteen strain gages, and the test time were recorded. The strain rates for all tests ranged from  $10^{-5}$  to  $10^{-1}$  in./in./sec..

4. Test Results. Based on the load-strain diagram obtained from the paired strain gages attached back to back along the centerline of the web, it can be seen that no local buckling occurred in the web prior to the attainment of the maximum load. There is no evidence that failure of the bonding material occurred before the test specimen reached its

ultimate load. The failure mode of the stub column varies with the width-to-thickness ratio of unstiffened elements. Same as the stub columns with stiffened elements, no local buckling occurred in the unstiffened flanges of the specimens with small  $w/t$  ratios (case A of Group II for using 35XF and 50XF sheet steels). For specimens with medium  $w/t$  ratios, (i.e., case B of Group II for using 35XF and 50XF sheet steels), the unstiffened flanges buckled locally in the inelastic range. The local buckling occurred in the elastic range for the specimens with large  $w/t$  ratios (cases C and D of Group II for using 35XF and 50XF sheet steels). Typical load-strain relationship for the specimens with large  $w/t$  ratios is shown in Figure 2.28.

Figure 2.29 shows the local buckling mode developed in the stub column specimen with large  $w/t$  ratios. Four typical load-displacement relationships are shown in Figures 2.30 to 2.33 for I-shaped stub columns fabricated from 35XF sheet steel and tested under different strain rates. The average  $w/t$  ratio of unstiffened elements and the strain rates used in the tests are indicated in each figure. Similarly, Figures 2.34 to 2.37 show four typical load-displacement curves for I-shaped stub columns fabricated from 50XF sheet steel. The value of strain rate for each test was determined from the strain-time relationship. A typical strain-time diagram is shown in Figure 2.38. The tested ultimate loads are presented in Tables 2.10 and 2.11 for the I-shaped stub columns fabricated from 35XF and 50XF sheet steels, respectively.

### III. EVALUATION OF EXPERIMENTAL DATA

#### A. GENERAL

The width-to-thickness ratio of stiffened and unstiffened elements controls the failure mode of the stub column. The objective of this investigation was to study the validity of the effective width formula being using in the current AISI Automotive Steel Design Manual for determining the structural strength of members subjected to dynamic loads. To study the behavior of stiffened and unstiffened compression elements, two types of stub column specimens fabricated from two sheet steels (35XF and 50XF sheet steels) were tested under different strain rates. Comparisons between the test results and the predicted values are presented in this chapter.

#### B. STUB COLUMN TESTS FOR THE STUDY OF STIFFENED ELEMENTS

Box-shaped stub columns fabricated from 35XF and 50XF sheet steels were tested for studying the postbuckling strength of stiffened elements. All stub column specimens were tested under uniform compressive load. The compressive yield stress obtained from material tests was used for calculating the critical local buckling load ( $P_{cr}$ ) and the ultimate load ( $P_u$ ) of stub columns.

1. Critical Local Buckling Load. The compression element of stub column specimens may buckle locally in the elastic or inelastic range,

depending on the  $w/t$  ratio of the compression element. The elastic critical local buckling stress,  $(f_{cr})_E$ , of stiffened elements subjected to a uniform compressive load can be calculated by using Equation 3.2 which is derived from Bryan's differential equation (Equation 3.1) based on small deflection.

$$\frac{\partial^4 \omega}{\partial x^4} + 2 \frac{\partial^4 \omega}{\partial x^2 \partial y^2} + \frac{\partial^4 \omega}{\partial y^4} = - \frac{f_x t}{D} \frac{\partial^2 \omega}{\partial x^2} \quad (3.1)$$

where  $\omega$  = lateral deflection of the plate

$t$  = thickness of the plate

$D = Et^3 / (12(1 - \mu^2))$

$f_x$  = stress components normal to the edges of the plate

$$(f_{cr})_E = \frac{k\pi^2 E}{12(1 - \mu^2)(w/t)^2} \quad (3.2)$$

where  $E$  = modulus of elasticity

$\mu$  = Poisson's ratio = 0.3 for steel

$k$  = buckling coefficient

$t$  = thickness of element

$w$  = width of element

When the elastic critical buckling stress exceeds the proportional limit, the compression element buckles in the inelastic range. Therefore, the

concept of tangent modulus<sup>9</sup> can be applied to calculate the inelastic buckling stress,  $(f_{cr})_I$ , by using Equation 3.3.

$$(f_{cr})_I = F_y - \frac{F_{pr}(F_y - F_{pr})}{(f_{cr})_E} \quad (3.3)$$

where  $F_y$  = compressive yield stress of steel

$F_{pr}$  = proportional limit of steel

$(f_{cr})_E$  = elastic critical local buckling stress

The critical local buckling load of a stub column can be predicted by using Equation 3.4. The buckling coefficient used to compute the critical buckling stress,  $f_{cr}$ , ( $(f_{cr})_E$  or  $(f_{cr})_I$ ) in Equation 3.2 is equal to 4.0 for stiffened compression elements supported along both longitudinal edges. Consequently, the critical buckling load is

$$P_{cr} = A_t f_{cr} \quad (3.4)$$

where  $f_{cr}$  = critical buckling stress

$A_t$  = total cross-sectional area of the stub column

The predicted critical local buckling loads determined from Equation 3.4 and the critical local buckling loads obtained from the test results are presented in Tables 3.1 and 3.2 for 35XF and 50XF sheet steels, respectively. The values listed in column (1) of Tables 3.1 and 3.2 are the average values of the tested critical local buckling stresses of stiffened compression flanges of stub columns. The predicted critical

local buckling loads shown in column (2) of Tables 3.1 and 3.2 were calculated on the basis of dynamic material properties.

The tested critical local buckling loads listed in column (3) of Tables 3.1 and 3.2 were determined from load-strain relationships by using the modified strain reversal method. The load-strain relationships indicate that no local buckling occurred in the specimens with small and medium w/t ratios for both sheet steels. The comparisons of computed and tested local critical buckling loads are listed in column (4) of Tables 3.1 and 3.2. The mean values of  $(P_{cr})_{test}/(P_{cr})_{comp}$  ratios for 35XF and 50XF sheet steels are 1.030 and 0.891 with standard deviations of 0.189 and 0.102, respectively. It seems that the predicated buckling loads for box-shaped stub columns fabricated from 50XF sheet steel are less conservative than the stub columns fabricated from 35XF sheet steel. It was also observed from Tables 3.1 and 3.2 that the ratio of  $(P_{cr})_{test}/(P_{cr})_{comp}$  increases with increasing strain rate for stub columns with relatively large w/t ratios, except for the stub columns with extra large w/t ratios for 50XF sheet steel.

2. Ultimate Axial Load. It is assumed that a stub column reaches its ultimate load when the maximum edge stress in the stiffened flanges reaches the yield stress of steel. The ultimate load can be calculated from the effective cross-sectional area of the stub column and the compressive yield stress of steel as expressed in Equation 3.6. The concept of effective width formula<sup>1</sup> (Equation 3.5) can be used to compute the effective cross-sectional area. i.e.,

$$b = w \quad \text{when} \quad \lambda \leq 0.673, \quad (3.5a)$$

$$b = \rho w \quad \text{when} \quad \lambda > 0.673, \quad (3.5b)$$

where  $b$  = effective width of a compression element

$w$  = flat width of a compression element

$$\rho = (1 - 0.22 / \lambda) / \lambda$$

$\lambda$  = a slenderness factor

$$\lambda = \frac{1.052}{\sqrt{k}} \left( \frac{w}{t} \right) \left( \sqrt{\frac{f}{E}} \right) \quad (3.5c)$$

where  $f$  = the edge stress

$E$  = modulus of elasticity, 29500 ksi

$k$  = plate buckling coefficient

$$P_u = A_e f_y \quad (3.6)$$

where  $A_e$  = effective cross-sectional area of the stub column

$F_y$  = static or dynamic yield stress of steel

The predicted ultimate loads computed from Equation 3.6 and the ultimate loads obtained from tests are presented in Tables 3.3(a) and 3.3(b) for 35XF sheet steel. Tables 3.4(a) and 3.4(b) present the similar values for 50XF sheet steel. The computed ultimate loads listed in column (5) of Tables 3.3(a) and 3.4(a) are based on the static compressive yield stress, while the values listed in column (5) of Tables 3.3(b) and 3.4(b) are based on the dynamic compressive yield stress corresponding to the



strain rate used in the test. The tested ultimate loads are listed in column (6) of Tables 3.3 and 3.4. Comparisons of the computed loads based on the static yield stress and the tested ultimate loads are listed in column (7) of Tables 3.3(a) and 3.4(a). The mean values of  $(P_u)_{\text{test}}/(P_u)_{\text{comp}}$  ratios for the box-shaped sections made of 35XF and 50XF sheet steels are 1.222 and 1.020 with standard deviations of 0.149 and 0.061, respectively. Comparisons of the computed loads based on the dynamic yield stress and the tested ultimate loads are listed in column (7) of Tables 3.3(b) and 3.4(b). The mean values and standard deviations of  $(P_u)_{\text{test}}/(P_u)_{\text{comp}}$  ratios are (1.148, 0.105) for using 35XF sheet steel and (0.981, 0.044) for using 50XF sheet steel.

For the purpose of comparison, Figures 3.1 and 3.2 show graphically the effect of strain rate on the ratios of the tested ultimate load to the computed ultimate load obtained from Tables 3.3(a) and 3.3(b), respectively. Similarly, Figures 3.3 and 3.4 show the strain rates vs. the ratios of the tested ultimate load to the computed ultimate load obtained from Tables 3.4(a) and 3.4(b). Tables 3.5 and 3.6 list average failure loads obtained from Tables 2.8 and 2.9, respectively. Each value given in Tables 3.5 and 3.6 and each point shown in Figures 3.1 through 3.4 is the average of two values obtained from similar tests, except for the stub columns with extra large w/t ratios for using 50XF sheet steel.

By comparing the mean values and standard deviations of  $(P_u)_{\text{test}}/(P_u)_{\text{comp}}$  ratios listed in Tables 3.3(a) and 3.4(a) with those listed in Tables 3.3(b) and 3.4(b), it can be seen that the computed

ultimate loads using dynamic yield stresses are better than the computed ultimate loads using static yield stress. Similar to the results of critical local buckling loads listed in Tables 3.1 and 3.2, all predicted ultimate loads are lower than the tested ultimate loads for using 35XF sheet steel. However for using 50XF sheet steel, some predicted ultimate loads are higher than the tested ultimate loads. The predicted ultimate loads for box-shaped stub columns fabricated from 50XF sheet steel are found to be less conservative than the stub columns fabricated from 35XF sheet steel. It is also noted from Tables 3.5 and 3.6 that the tested ultimate load increases with strain rate for specimens having the same  $w/t$  ratios. Comparisons between the tested ultimate loads and the predicted ultimate loads based on tensile yield stresses with the effect of cold work are presented in Appendix A.

### C. STUB COLUMN TESTS FOR THE STUDY OF UNSTIFFENED ELEMENTS

I-shaped stub columns fabricated from 35XF and 50XF sheet steels were tested for studying the postbuckling strength of unstiffened elements. As mentioned in Chapter II, the length of specimen was designed to prevent overall column buckling failure, and the stiffened webs of channel sections used to form I-shaped specimens were designed to be fully effective. All stub column specimens were tested under a uniform compressive load. The compressive yield stresses obtained from material tests were used for the evaluation of all stub column specimens in this section.

1. Critical Local Buckling Load. Similar to stiffened elements, unstiffened elements of stub columns may buckle locally in the elastic or inelastic range, depending on the w/t ratio of the compression element. Equations 3.2 and 3.3 can be applied to calculate the elastic critical local buckling stress  $((f_{cr})_E)$  and the inelastic critical local buckling stress  $((f_{cr})_I)$  of unstiffened elements subjected to a uniform compressive load. A "k" value of 0.43 was used for buckling coefficient in Equation 3.2 for the calculation of critical local buckling stress  $(f_{cr})$ . The critical local buckling loads of stub columns can be predicted by using Equation 3.4.

The computed and tested critical local buckling loads of stub column specimens are given in Tables 3.7 and 3.8 for 35XF and 50XF sheet steels, respectively. The computed critical local buckling loads listed in Tables 3.7 and 3.8 were calculated on the basis of the dynamic material properties. The values given in column (1) of Tables 3.7 and 3.8 are the average values of four critical local buckling stresses of unstiffened compression flanges of stub columns.

The tested critical local buckling loads listed in column (3) of Tables 3.7 and 3.8 were determined from the load-strain relationships by using the modified strain reversal method. It is noted that no local buckling occurred in the specimens with small and medium w/t ratios for both sheet steels. Column (4) of Tables 3.7 and 3.8 show the comparisons between the computed and tested critical local buckling loads. The mean values of  $(P_{cr})_{test}/(P_{cr})_{comp}$  ratios for using 35XF and 50XF sheet steels

are 1.684 and 1.585 with standard deviations of 0.240 and 0.354, respectively. These large mean values indicate that for most of test specimens, initial local buckling did not occur at the location of strain gages. In addition, the actual buckling coefficient "k" could be greater than the value of 0.43 used in Equation 3.4.

2. Ultimate Axial Load. It is assumed that a stub column reaches its ultimate load when the maximum edge stress in the unstiffened flanges reaches the yield stress of steel. The ultimate load-carrying capacities ( $P_u$ ) of stub columns can be predicted from Equation 3.6. The effective width formula given in Equation 3.5 can be applied for the calculation of the effective cross-sectional area to be used in Equation 3.6.

The predicated ultimate loads computed from Equation 3.6 and the ultimate loads obtained from tests are presented in Tables 3.9(a) and 3.9(b) for using 35XF sheet steel. Tables 3.10(a) and 3.10(b) present the similar values for using 50XF sheet steel. The computed ultimate loads based on the static compressive yield stresses are given in column (5) of Tables 3.9(a) and 3.10(a), while the computed ultimate loads based on the dynamic compressive yield stresses are given in Tables 3.9(b) and 3.10(b). The values listed in column (6) of Tables 3.9 and 3.10 are ultimate loads obtained from tests. Comparisons of the computed ultimate loads based on the static yield stress and the tested ultimate loads are listed in column (7) of Tables 3.9(a) and 3.10(a). The mean values of  $(P_u)_{\text{test}} / (P_u)_{\text{comp}}$  ratios for using 35XF and 50XF sheet steels are 1.410 and 1.162 with standard deviations of 0.132 and 0.064, respectively. The

values listed in column (7) of Tables 3.9(b) and 3.10(b) are the comparisons between the computed ultimate loads based on the dynamic yield stresses and the tested ultimate loads. The mean values and standard deviations of  $(P_u)_{\text{test}}/(P_u)_{\text{comp}}$  ratios are (1.330, 0.067) for using 35XF sheet steel and (1.121, 0.044) for using 50XF sheet steel.

For the purpose of comparison, Figures 3.5 and 3.6 show graphically the effect of strain rate on the ratios of the tested ultimate load to the computed ultimate load obtained from Tables 3.9(a) and 3.9(b), respectively. Similarly, Figures 3.7 and 3.8 show the strain rates vs. the ratios of the tested ultimate load to the computed ultimate load obtained from Tables 3.10(a) and 3.10(b). Tables 3.11 and 3.12 list average failure loads obtained from Tables 2.10 and 2.11, respectively. Each value given in Tables 3.11 and 3.12 and each point shown in Figures 3.5 through 3.8 is the average of two values obtained from similar tests, except for the stub columns with extra large w/t ratios for using 50XF sheet steel.

From Tables 3.9 and 3.10, it can be seen that the computed ultimate loads using the dynamic yield stresses are better than the computed ultimate loads using the static yield stresses. Similar to the results for studying box-shaped stub columns, the predicted ultimate loads for I-shaped stub columns fabricated from 50XF sheet steel are less conservative than the stub columns fabricated from 35XF sheet steel. Tables 3.11 and 3.12 indicate that the tested ultimate load increases with strain rate for the specimens having the same w/t ratio. Comparisons

between the tested ultimate loads and the predicted ultimate loads based on tensile yield stresses with the effect of cold work are presented in Appendix A.

#### IV. CONCLUSIONS

In view of the fact that material properties can be influenced by the strain rate, the main purpose of this phase of study dealt with the effect of strain rate on the structural strengths of cold-formed members, having stiffened or unstiffened elements, subjected to dynamic loads.

During the period from May 1988 through July 1989, the material properties of three different sheet steels (35XF, 50XF, and 100XF) have been tested and studied for various strain rates with a consideration of tension and compression. The test results obtained from this investigation were presented in the Eleventh and Twelfth Progress Reports.

Prior to April 1990, 18 box-shaped stub columns (cases A, B, and C of Group I) and 19 I-shaped stub columns (cases A, B, and C of Group II) fabricated from 35XF sheet steel were tested to study the strengths of stiffened and unstiffened elements. The test results were presented in the Thirteenth Progress Report. Since May 1990, six additional box-shaped stub columns (case D of Group I) fabricated from 35XF sheet steel and 22 box-shaped stub columns (cases A, B, C, and D of Group I) fabricated from 50XF sheet steel were tested to study the strengths of stiffened elements. In addition, six additional I-shaped stub columns (case D of Group II) fabricated from 35XF sheet steel and 26 I-shaped stub columns (cases A, B, C, and D of Group II) fabricated from 50XF sheet steel were tested to study the strengths of unstiffened elements.

In Chapter II, the experimental investigation of stub columns are discussed in detail. The evaluation of test data is presented in Chapter

III. Based on the available test results, tentative conclusions are drawn as follows :

1. For most of the cases, the ultimate loads of box-shaped and I-shaped stub columns fabricated from 35XF and 50XF sheet steels increase with increasing strain rates.
2. From the test results on box-shaped and I-shaped stub columns, the predicted ultimate loads for the stub columns fabricated from 50XF sheet steel are found to be less conservative than the stub columns fabricated from 35XF sheet steel.
3. From the test results of the stub columns fabricated from 35XF and 50XF sheet steels, it can be seen that the predicted ultimate loads of the stub columns for studying stiffened elements are less conservative than the stub columns for studying unstiffened elements.
4. The computed ultimate loads using the dynamic yield stresses are better than the computed ultimate loads using the static yield stresses.
5. The computed ultimate strength based on the AISI Automotive Design Manual was found to be conservative for most of the stub columns tested.
6. Future tests are planned for a study of the effect of strain rate on the structural strength of cold-formed steel beams having stiffened or unstiffened flanges. These specimens have been fabricated from 50XF sheet steel.



## ACKNOWLEDGMENTS

The research work reported herein was conducted in the Department of Civil Engineering at the University of Missouri-Rolla under the sponsorship of the American Iron and Steel Institute.

The financial assistance granted by the Institute and the technical guidance provided by members of the Task Force on Automotive Structural Design and the AISI Automotive Applications Committee and the AISI staff are gratefully acknowledged. These members are: Messrs. S. J. Errera (Chairman), J. Borchelt, R. Cary, J. D. Harrington, F. L. Cheng, A. M. Davies, J. D. Grozier, C. Haddad, C. S. Jayanth, A. L. Johnson, C. M. Kim, J. P. Leach, K. H. Lin, J. N. Macadam, H. Mahmood, D. Malen, J. McDermott, J. G. Schroth, P. G. Schurter, T. N. Seel, M. F. Shi, and M. T. Vecchio. An expression of thanks is also due to Mr. D. L. Douty for his help.

All materials used in the experimental study were donated by Inland Steel Company and LTV Steel Company.

Appreciation is expressed to Messrs. K. Haas, J. Bradshaw, F. Senter, J. Tucker, and S. Gabel, staff of the Department of Civil Engineering, for their technical support and to Mr. M. Y. Shan for his valuable assistance in the preparation and performance of the tests. The advice provided by Dr. J. E. Minor, Chairman of the UMR Department of Civil Engineering, is greatly appreciated.

## REFERENCES

1. American Iron and Steel Institute, Automotive Steel Design Manual , 1986 Edition, Revision 2 - December 1988.
2. Kassab, M. and Yu, W.W., "Design of Automotive Structural Components Using High Strength Sheet Steels: The Effect of Strain Rate on Mechanical Properties of Sheet Steels", Eleventh Progress Report, Civil Engineering Study 89-2, University of Missouri-Rolla, January 1989.
3. Kassab, M. and Yu, W.W., "Design of Automotive Structural Components Using High Strength Sheet Steels: The Effect of Strain Rate on Compressive Mechanical Properties of Sheet Steels", Twelfth Progress Report, Civil Engineering Study 89-3, University of Missouri-Rolla, August 1989.
4. Kassab, M. and Yu, W.W., "Design of Automotive Structural Components Using High Strength Sheet Steels: Structural Strengths of Cold-Formed Steel Members Under Dynamic Loads of Sheet Steels", Thirteenth Progress Report, Civil Engineering Study 90-1, University of Missouri-Rolla, May 1990.
5. Kassab, M. and Yu, W.W., "Design of Automotive Structural Components Using High Strength Sheet Steels: Effect of Strain Rate on Material Properties of Sheet Steels and Structural Strengths of Cold-Formed Steel Members", Fourteenth Progress Report, Civil Engineering Study 90-2, University of Missouri-Rolla, May 1990.
6. Galambos, T. V. (ed.), Guide to Stability Design Criteria for Metal Structures , 4th Edition, New York: John Wiley & Sons Inc., 1988.
7. American Iron and Steel Institute, Cold-Formed Steel Design Manual , 1986 Edition.
8. Johnson, A. L. and Winter, G., "The Structural Performance of Austenitic Stainless Steel Members," Report No. 327 , Cornell University, Nov., 1966.
9. Bleich, F., Buckling Strength of Metal Structures , New York: McGraw-Hill Book Company, 1952.

Table 2.1

## Designation of Test Specimens Used in This Study

1st Digit	1st Letter	2nd Digit	2nd Letter
Section Type (Group)	w/t Ratio (Case)	Strain-Rate (in./in./sec.)	Test No.
1- Box-Shaped Section	A- Small Ratio	0- 0.00001	A- 1st Test
Stub-Column Test	B- Medium Ratio	1- 0.0001	B- 2nd Test
2- I-Shaped Section	C- Large Ratio	2- 0.01	
Stub-Column Test	D- Extra Large Ratio	3- 0.1	

Note: The fifth character (X) in the designation of test specimens represents the specimen fabricated from 50XF sheet steel.

Table 2.2  
 Number of Performed Stub Column Tests  
 Box Sections Having Stiffened Compression Elements  
 (35XF Sheet Steel)

Spec. No.	Test Speed in./min.	Strain Rate (in./in./sec.)	w/t	L/r	No. of Tests Performed
1A1A	0.072	0.0001	27.15	12.26	1
1A1B	0.072	0.0001	27.39	12.26	1
1A2A	7.2	0.01	26.92	12.26	1
1A2B	7.2	0.01	27.06	12.26	1
1A3A	72.0	0.1	27.31	12.26	1
1A3B	72.0	0.1	27.40	12.26	1
1B1A	0.084	0.0001	38.93	10.98	1
1B1B	0.084	0.0001	38.17	10.98	1
1B2A	8.4	0.01	38.86	10.98	1
1B2B	8.4	0.01	39.10	10.98	1
1B3A	84.0	0.1	38.86	10.98	1
1B3B	84.0	0.1	38.96	10.98	1
1C1A	0.09	0.0001	52.69	11.27	1
1C1B	0.09	0.0001	52.96	11.27	1
1C2A	9.0	0.01	52.20	11.27	1
1C2B	9.0	0.01	53.06	11.27	1
1C3A	90.0	0.1	53.15	11.27	1
1C3B	90.0	0.1	53.39	11.27	1
1D1A	0.18	0.0001	100.68	12.52	1
1D1B	0.18	0.0001	100.35	12.46	1
1D2A	18.0	0.01	100.49	12.52	1
1D2B	18.0	0.01	100.62	12.54	1
1D3A	89.9	0.05	100.85	12.56	1
1D3B	89.7	0.05	100.72	12.49	1
<b>Total</b>					24

Table 2.3  
 Number of Performed Stub Column Tests  
 Box Sections Having Stiffened Compression Elements  
 (50XF Sheet Steel)

Spec. No.	Test Speed in./min.	Strain Rate (in./in./sec.)	w/t	L/r	No. of Tests Performed
1A1AX	0.0896	0.0001	23.89	13.21	1
1A1BX	0.0899	0.0001	23.15	13.17	1
1A2AX	9.00	0.01	23.15	13.18	1
1A2BX	8.97	0.01	22.94	13.20	1
1A3AX	44.9	0.05	23.10	13.15	1
1A3BX	44.9	0.05	22.92	13.15	1
1B1AX	0.0899	0.0001	35.15	11.00	1
1B1BX	0.0898	0.0001	34.59	10.98	1
1B2AX	8.94	0.01	34.50	10.96	1
1B2BX	9.01	0.01	34.96	10.99	1
1B3AX	36.0	0.04	34.97	10.95	1
1B3BX	35.9	0.04	34.79	10.97	1
1C1AX	0.0896	0.0001	52.76	10.29	1
1C1BX	0.0896	0.0001	53.40	10.31	1
1C2AX	8.96	0.01	53.06	10.33	1
1C2BX	8.96	0.01	52.23	10.28	1
1C3AX	35.9	0.04	51.67	10.32	1
1C3BX	35.9	0.04	52.90	10.26	1
1D1AX	0.156	0.0001	97.99	12.12	1
1D2AX	15.5	0.01	98.21	12.10	1
1D3AX	46.7	0.03	98.01	12.10	1
1D3BX	46.7	0.03	98.07	12.08	1
<b>Total</b>					<b>22</b>

Table 2.4  
 Number of Performed Stub Column Tests  
 I-Sections Having Unstiffened Compression Elements  
 (35XF Sheet Steel)

Spec. No.	Test Speed in./min.	Strain Rate (in./in./sec.)	w/t	L/r	No. of Tests Performed
2A1A	0.054	0.0001	8.93	18.73	1
2A1B	0.054	0.0001	9.04	18.73	1
2A2A	5.4	0.01	8.93	18.73	1
2A2B	5.4	0.01	9.10	18.73	1
2A3A	54.0	0.1	8.93	18.73	1
2A3B	54.0	0.1	8.96	18.73	1
2B1A	0.06	0.0001	13.34	17.65	1
2B1B	0.06	0.0001	13.41	17.65	1
2B2A	6.0	0.01	13.40	17.65	1
2B2B	6.0	0.01	13.37	17.65	1
2B3A	60.0	0.1	13.34	17.65	1
2B3B	60.0	0.1	13.42	17.65	1
2C0A	0.0084	0.00001	20.69	15.64	1
2C1A	0.084	0.0001	20.85	15.64	1
2C1B	0.084	0.0001	20.76	15.64	1
2C2A	8.4	0.01	20.97	15.64	1
2C2B	8.4	0.01	20.81	15.64	1
2C3A	84.0	0.1	20.93	15.64	1
2C3B	84.0	0.1	20.87	15.64	1
2D1A	0.144	0.0001	44.60	16.57	1
2D1B	0.144	0.0001	44.50	16.55	1
2D2A	14.4	0.01	44.62	16.69	1
2D2B	14.4	0.01	44.59	16.64	1
2D3A	71.7	0.05	44.51	16.85	1
2D3B	71.8	0.05	44.60	16.58	1
<b>Total</b>					<b>25</b>

Table 2.5  
 Number of Performed Stub Column Tests  
 I-Sections Having Unstiffened Compression Elements  
 (50XF Sheet Steel)

Spec. No.	Test Speed in./min.	Strain Rate (in./in./sec.)	w/t	L/r	No. of Tests Performed
2A1AX	0.0418	0.0001	8.41	19.01	1
2A1BX	0.0419	0.0001	8.38	19.12	1
2A2AX	4.19	0.01	8.40	19.08	1
2A2BX	4.18	0.01	8.38	19.08	1
2A3AX	33.6	0.08	8.29	19.39	1
2A3BX	33.4	0.08	8.36	19.16	1
2B1AX	0.0539	0.0001	11.68	20.20	1
2B1BX	0.0536	0.0001	11.60	20.29	1
2B1CX	0.0054	0.00001	11.63	20.37	1
2B2AX	5.38	0.01	11.58	20.43	1
2B2BX	5.40	0.01	11.54	20.61	1
2B2CX	0.54	0.001	11.53	20.51	1
2B3AX	43.2	0.08	11.65	20.34	1
2B3BX	43.1	0.08	11.50	20.53	1
2C1AX	0.0896	0.0001	22.84	16.85	1
2C1BX	0.0898	0.0001	22.73	16.99	1
2C2AX	8.96	0.01	22.77	16.91	1
2C2BX	8.97	0.01	22.76	16.94	1
2C3AX	44.9	0.05	22.72	16.97	1
2C3BX	44.8	0.05	22.79	16.90	1
2D1AX	0.108	0.0001	35.37	15.31	1
2D1BX	0.108	0.0001	35.33	15.32	1
2D2AX	10.8	0.01	35.26	15.30	1
2D2BX	11.8	0.01	35.21	15.29	1
2D3AX	43.1	0.04	35.29	15.32	1
2D3BX	43.1	0.04	35.15	15.28	1
<b>Total</b>					<b>26</b>

Table 2.6

Average Mechanical Properties of 35XF Sheet Steel Used in  
the Experimental Study Under Different Strain Rates

Strain Rate in./in./sec.	$(F_y)_c$ (ksi)	$(F_{pr})_c$ (ksi)	$(F_y)_t$ (ksi)	$(F_u)_t$ (ksi)	Elongation (%)
0.0001	29.83	17.79	32.87	49.35	38.90
0.01	31.92	20.03	36.40	51.76	36.80
1.0	36.91	*****	42.37	56.63	40.90

## Notes:

- 1)  $(F_y)_c$  and  $(F_{pr})_c$  are based on longitudinal compression coupon tests.
- 2)  $(F_y)_t$  and  $(F_u)_t$  and Elongation are determined from longitudinal tension coupon tests.
- 3) Elongation was measured by using a 2-in. gage length.



Table 2.7

Average Mechanical Properties of 50XF Sheet Steel Used in  
the Experimental Study Under Different Strain Rates

Strain Rate in./in./sec.	$(F_y)_c$ (ksi)	$(F_{pr})_c$ (ksi)	$(F_y)_t$ (ksi)	$(F_u)_t$ (ksi)	Elongation (%)
0.0001	49.68	38.64	49.50	72.97	31.00
0.01	52.51	40.05	51.60	74.87	27.00
1.0	54.79	*****	54.66	78.73	25.80

## Notes:

- 1)  $(F_y)_c$  and  $(F_{pr})_c$  are based on longitudinal compression coupon tests.
- 2)  $(F_y)_t$  and  $(F_u)_t$  and Elongation are determined from longitudinal tension coupon tests.
- 3) Elongation was measured by using a 2-in. gage length.

Table 2.8  
 Dimensions of Stub Columns with Stiffened Flanges  
 Fabricated from 35XF Sheet Steel  
 (35XF Sheet Steel)

Specimen	BF (in.)	BW (in.)	BL (in.)	w/t	Gross Area (in. <sup>2</sup> )	L (in.)	(P <sub>u</sub> ) <sub>test</sub> (kips)
1A1A	2.790	1.492	0.916	27.15	1.2060	12.03	46.12
1A1B	2.811	1.482	0.915	27.39	1.2060	12.02	44.89
1A2A	2.771	1.484	0.918	26.92	1.2010	12.03	50.02
1A2B	2.783	1.482	0.916	27.06	1.2060	12.03	49.29
1A3A	2.804	1.470	0.916	27.31	1.2009	12.03	53.54
1A3B	2.812	1.467	0.915	27.40	1.2009	12.03	54.37
1B1A	3.792	1.990	0.922	38.93	1.5477	14.99	49.19
1B1B	3.812	1.985	0.918	39.17	1.5480	13.97	53.54
1B2A	3.786	1.978	0.918	38.86	1.5412	13.84	56.28
1B2B	3.806	1.982	0.919	39.10	1.5463	13.94	57.01
1B3A	3.786	1.992	0.919	38.86	1.5463	13.84	64.78
1B3B	3.794	1.982	0.918	38.96	1.5440	13.94	60.87
1C1A	4.961	2.523	0.919	52.69	1.9266	15.06	56.76
1C1B	4.984	2.513	0.922	52.96	1.9282	15.06	56.52
1C2A	4.920	2.524	0.920	52.20	1.9203	14.81	61.02
1C2B	4.993	2.519	0.922	53.06	1.9317	15.12	64.58
1C3A	5.000	2.526	0.919	53.15	1.9343	15.09	73.96
1C3B	5.021	2.510	0.922	53.39	1.9334	15.00	69.27
1D1A	9.041	3.008	1.024	100.68	2.8207	29.91	63.85
1D1B	9.012	3.026	1.019	100.35	2.8203	29.92	63.90
1D2A	9.024	3.011	1.018	100.49	2.8169	29.93	70.35
1D2B	9.035	3.009	1.020	100.62	2.8188	29.94	69.22
1D3A	9.055	3.002	1.021	100.85	2.8202	29.95	74.06
1D3B	9.044	3.014	1.009	100.72	2.8183	29.91	72.45

Note : \* For symbols BF, BW, and BL, see Figure 2.9.

\* The nominal thickness of the stub column specimens fabricated from 35XF sheet steel is 0.085 inch.

Table 2.9  
 Dimensions of Stub Columns with Stiffened Flanges  
 Fabricated from 50XF Sheet Steel  
 (50XF Sheet Steel)

Specimen	BF (in.)	BW (in.)	BL (in.)	w/t	Gross Area (in. <sup>2</sup> )	L (in.)	(P <sub>u</sub> ) <sub>test</sub> (kips)
1A1AX	2.229	1.963	0.923	22.89	1.1569	14.94	57.89
1A1BX	2.249	1.982	0.921	23.15	1.1652	14.99	57.65
1A2AX	2.249	1.960	0.921	23.15	1.1584	15.00	59.82
1A2BX	2.233	1.967	0.923	22.94	1.1587	14.95	60.23
1A3AX	2.245	1.963	0.927	23.10	1.1605	14.98	63.95
1A3BX	2.231	1.961	0.938	22.92	1.1612	14.95	62.04
1B1AX	3.173	1.969	0.926	35.15	1.3050	14.98	62.19
1B1BX	3.130	1.978	0.926	34.59	1.3012	14.97	61.75
1B2AX	3.123	1.983	0.919	34.50	1.2995	14.99	68.88
1B2BX	3.158	1.977	0.926	34.95	1.3052	15.01	67.86
1B3AX	3.159	1.979	0.921	34.97	1.3044	14.98	71.42
1B3BX	3.145	1.975	0.934	34.79	1.3050	14.94	71.52
1C1AX	4.529	1.967	0.923	52.76	1.5123	14.94	60.09
1C1BX	4.578	1.962	0.936	53.40	1.5223	14.94	60.67
1C2AX	4.552	1.968	0.928	53.06	1.5177	14.94	64.00
1C2BX	4.488	1.971	0.928	52.23	1.5087	14.93	66.44
1C3AX	4.445	1.972	0.923	51.67	1.5009	14.97	66.54
1C3BX	4.540	1.975	0.926	52.90	1.5174	14.96	69.47
1D1AX	8.012	2.719	1.014	97.99	2.3083	25.94	76.94
1D2AX	8.029	2.719	1.009	98.21	2.3094	25.92	82.22
1D3AX	8.013	2.725	1.018	98.01	2.3115	25.94	82.46
1D3BX	8.018	2.727	1.018	98.07	2.3129	25.92	80.85

Note : \* For symbols BF, BW, and BL, see Figure 2.9.

\* The nominal thickness of the stub column specimens fabricated from 50XF sheet steel is 0.077 inch.

Table 2.10  
 Dimensions of Stub Columns with Unstiffened Flanges  
 Fabricated from 35XF Sheet Steel  
 (35XF Sheet Steel)

Specimen	BC (in.)	D (in.)	w/t	Gross Area (in. <sup>2</sup> )	L (in.)	(P <sub>u</sub> ) <sub>test</sub> (kips)
2A1A	1.000	2.000	8.93	0.6220	7.90	25.26
2A1B	1.010	2.018	9.04	0.6285	7.97	25.35
2A2A	1.000	2.040	8.93	0.6288	7.95	26.04
2A2B	1.015	2.002	9.10	0.6275	7.94	27.70
2A3A	1.000	2.040	8.93	0.6288	7.98	31.41
2A3B	1.003	2.014	8.96	0.6254	7.94	29.41
2B1A	1.375	3.025	13.34	0.9238	9.95	34.20
2B1B	1.381	2.981	13.41	0.9184	9.97	34.20
2B2A	1.380	2.987	13.40	0.9190	9.96	36.30
2B2B	1.378	3.007	13.37	0.9217	9.94	37.52
2B3A	1.375	3.020	13.34	0.9229	10.01	41.67
2B3B	1.382	3.006	13.42	0.9229	9.99	42.70
2C0A	2.000	3.000	20.69	1.1320	14.00	36.30
2C1A	2.014	2.976	20.85	1.1327	14.00	37.23
2C1B	2.006	3.018	20.76	1.1371	13.94	37.66
2C2A	2.024	2.967	20.97	1.1346	14.09	41.28
2C2B	2.010	3.015	20.81	1.1380	13.95	41.52
2C3A	2.020	2.970	20.93	1.1337	14.06	47.92
2C3B	2.015	2.977	20.87	1.1332	13.91	46.16
2D1A	4.032	3.302	44.60	1.8743	23.92	41.72
2D1B	4.024	3.311	44.50	1.8731	23.94	41.04
2D2A	4.034	3.278	44.62	1.8709	23.92	46.31
2D2B	4.031	3.289	44.59	1.8717	23.93	44.94
2D3A	4.025	3.241	44.51	1.8615	23.90	48.66
2D3B	4.032	3.301	44.60	1.8741	23.92	49.39

Note : \* For symbols BC and D, see Figure 2.26.

\* The nominal thickness of the stub column specimens fabricated from 35XF sheet steel is 0.085 inch.

Table 2.11  
 Dimensions of Stub Columns with Unstiffened Flanges  
 Fabricated from 50XF Sheet Steel  
 (50XF Sheet Steel)

Specimen	BC (in.)	D (in.)	w/t	Gross Area (in. <sup>2</sup> )	L (in.)	(P <sub>u</sub> ) <sub>test</sub> (kips)
2A1AX	0.881	1.949	8.41	0.5218	6.97	28.04
2A1BX	0.879	1.958	8.38	0.5225	6.98	28.16
2A2AX	0.880	1.956	8.40	0.5228	6.98	29.02
2A2BX	0.879	1.956	8.38	0.5224	6.97	29.43
2A3AX	0.872	1.975	8.29	0.5232	6.99	30.75
2A3BX	0.877	1.962	8.36	0.5226	6.96	30.95
2B1AX	1.133	2.961	11.68	0.7553	8.99	39.72
2B1BX	1.127	2.992	11.60	0.7582	8.94	39.18
2B1CX	1.129	2.994	11.63	0.7593	8.99	39.47
2B2AX	1.125	2.999	11.58	0.7589	8.97	42.60
2B2BX	1.122	3.024	11.54	0.7616	9.00	42.55
2B2CX	1.121	2.987	11.53	0.7558	8.98	41.77
2B3AX	1.131	2.986	11.65	0.7586	9.00	45.07
2B3BX	1.119	2.994	11.50	0.7563	8.97	45.94
2C1AX	1.992	3.043	22.84	1.0327	14.94	43.62
2C1BX	1.984	3.064	22.73	1.0333	14.96	43.97
2C2AX	1.987	3.047	22.77	1.0316	14.94	46.70
2C2BX	1.986	3.057	22.76	1.0329	14.95	46.26
2C3AX	1.983	3.041	22.72	1.0295	14.97	47.34
2C3BX	1.988	3.055	22.79	1.0333	14.94	46.85
2D1AX	2.957	2.717	35.37	1.2796	17.94	44.06
2D1BX	2.954	2.717	35.33	1.2786	17.94	44.50
2D2AX	2.948	2.719	35.26	1.2772	17.94	46.75
2D2BX	2.945	2.722	35.21	1.2767	17.94	47.58
2D3AX	2.951	2.715	35.29	1.2774	17.94	49.39
2D3BX	2.940	2.725	35.15	1.2754	17.94	48.95

Note : \* For symbols BC and D, see Figure 2.26..

\* The nominal thickness of the stub column specimens fabricated from 50XF sheet steel is 0.077 inch.

Table 3.1

Comparison of Computed and Tested Critical Buckling Loads  
Stub Columns with Stiffened Flanges (Based on  $k=4.0$ )  
(35XF Sheet Steel)

Specimen	$f_{cr}$ (ksi)	$(P_{cr})_{comp}$ (kips)	$(P_{cr})_{test}$ (kips)	$\frac{(3)}{(2)}$ (4)
	(1)	(2)	(3)	(4)
1A1A	28.35	34.19	N/A	N/A
1A1B	28.32	34.15	N/A	N/A
1A2A	30.30	36.39	N/A	N/A
1A2B	30.28	36.52	N/A	N/A
1A3A	32.16	38.62	N/A	N/A
1A3B	32.15	38.61	N/A	N/A
1B1A	26.79	41.46	N/A	N/A
1B1B	26.75	41.41	N/A	N/A
1B2A	28.55	44.00	N/A	N/A
1B2B	28.51	44.08	N/A	N/A
1B3A	30.22	46.73	N/A	N/A
1B3B	30.20	46.63	N/A	N/A
1C1A	24.25	46.72	50.56	1.082
1C1B	24.20	46.66	50.90	1.091
1C2A	25.83	49.60	58.09	1.171
1C2B	25.63	49.51	55.94	1.130
1C3A	26.88	51.99	66.15	1.272
1C3B	26.81	51.83	65.51	1.264
1D1A	10.52	29.68	22.96	0.774
1D1B	10.59	29.87	22.37	0.749
1D2A	10.56	29.75	22.23	0.747
1D2B	10.53	29.69	27.80	0.936
1D3A	10.49	29.57	30.29	1.024
1D3B	10.51	29.63	33.17	1.119
Mean				1.030
Standard Deviation				0.189

Table 3.2

Comparison of Computed and Tested Critical Buckling Loads  
Stub Columns with Stiffened Flanges (Based on  $k=4.0$ )  
(50XF Sheet Steel)

Specimen	$f_{cr}$ (ksi)	$(P_{cr})_{comp}$ (kips)	$(P_{cr})_{test}$ (kips)	$\frac{(3)}{(2)}$ (4)
1A1AX	47.58	55.05	N/A	N/A
1A1BX	47.54	55.39	N/A	N/A
1A2AX	50.00	57.92	N/A	N/A
1A2BX	50.05	57.99	N/A	N/A
1A3AX	50.70	58.84	N/A	N/A
1A3BX	50.74	58.92	N/A	N/A
1B1AX	44.74	58.38	N/A	N/A
1B1BX	44.89	58.41	N/A	N/A
1B2AX	46.94	61.00	N/A	N/A
1B2BX	46.79	61.07	65.27	1.069
1B3AX	47.19	61.55	N/A	N/A
1B3BX	47.25	61.66	N/A	N/A
1C1AX	38.31	57.94	46.12	0.796
1C1BX	37.40	56.94	45.92	0.806
1C2AX	37.88	58.02	47.39	0.817
1C2BX	39.10	58.99	52.51	0.890
1C3AX	39.95	59.96	50.07	0.835
1C3BX	38.11	57.82	52.76	0.912
1D1AX	11.11	25.64	21.98	0.857
1D2AX	11.06	25.53	28.04	1.098
1D3AX	11.11	25.67	21.59	0.841
1D3BX	11.08	25.65	22.47	0.876
Mean				0.891
Standard Deviation				0.102

Table 3.3(a)

Comparison of Computed and Tested Failure Loads Based on the  
Effective Width Formulas in the 1986 AISI Automotive Steel  
Design Manual for Stub Columns with Stiffened Flanges  
(35XF Sheet Steel)  
(Based on Static Compressive Yield Stress)

Spec.	Strain Rate (in./in./sec.)	w/t	$(F_y)_c$ (ksi)	$A_e$ (in. <sup>2</sup> )	$(P_u)_{comp}$ (kips)	$(P_u)_{test}$ (kips)	$\frac{(6)}{(5)}$ (7)
	(1)	(2)	(3)	(4)	(5)	(6)	(7)
1A1A	0.0001	27.15	29.83	1.2060	35.97	46.12	1.28
1A1B	0.0001	27.39	29.83	1.2058	35.97	44.89	1.25
1A2A	0.01	26.92	29.83	1.2007	35.82	50.02	1.40
1A2B	0.01	27.06	29.83	1.2014	35.82	49.29	1.38
1A3A	0.10	27.31	29.83	1.2009	35.82	53.54	1.49
1A3B	0.10	27.40	29.83	1.2009	35.82	54.37	1.52
1B1A	0.0001	38.93	29.83	1.5477	46.17	49.19	1.06
1B1B	0.0001	39.17	29.83	1.5480	46.18	53.54	1.16
1B2A	0.01	38.86	29.83	1.5412	45.97	56.28	1.22
1B2B	0.01	39.10	29.83	1.5463	46.13	57.01	1.23
1B3A	0.10	38.86	29.83	1.5463	46.13	64.78	1.40
1B3B	0.10	38.96	29.83	1.5440	46.06	60.87	1.32
1C1A	0.0001	52.69	29.83	1.8135	54.10	56.76	1.05
1C1B	0.0001	52.96	29.83	1.8122	54.06	56.52	1.05
1C2A	0.01	52.20	29.83	1.8122	54.06	61.02	1.13
1C2B	0.01	53.06	29.83	1.8147	54.13	64.58	1.19
1C3A	0.10	53.15	29.83	1.8164	54.18	73.96	1.36
1C3B	0.10	53.39	29.83	1.8130	54.08	69.27	1.28
1D1A	0.0001	100.68	29.83	2.1169	63.15	63.85	1.01
1D1B	0.0001	100.35	29.83	2.1210	63.27	63.90	1.01
1D2A	0.01	100.49	29.83	2.1157	63.11	70.35	1.11
1D2B	0.01	100.62	29.83	2.1158	63.12	69.22	1.10
1D3A	0.05	100.85	29.83	2.1141	63.06	74.06	1.17
1D3B	0.05	100.72	29.83	2.1139	63.06	72.45	1.15
Mean							1.222
Standard Deviation							0.149



Table 3.3(b)

Comparison of Computed and Tested Failure Loads Based on the  
 Effective Width Formulas in the 1986 AISI Automotive Steel  
 Design Manual for Stub Columns with Stiffened Flanges  
 (35XF Sheet Steel)  
 (Based on Dynamic Compressive Yield Stress)

Spec.	Strain Rate (in./in./sec.)	w/t	(F <sub>y</sub> ) <sub>c</sub> (ksi)	A <sub>e</sub> (in. <sup>2</sup> )	(P <sub>u</sub> ) <sub>comp</sub> (kips)	(P <sub>u</sub> ) <sub>test</sub> (kips)	$\frac{(6)}{(5)}$ (7)
1A1A	0.0001	27.15	29.83	1.2060	35.97	46.12	1.28
1A1B	0.0001	27.39	29.83	1.2058	35.97	44.89	1.25
1A2A	0.01	26.92	31.92	1.2007	38.33	50.02	1.30
1A2B	0.01	27.06	31.92	1.2014	38.35	49.29	1.29
1A3A	0.10	27.31	34.06	1.2009	40.90	53.54	1.31
1A3B	0.10	27.40	34.06	1.2009	40.90	54.37	1.33
1B1A	0.0001	38.93	29.83	1.5477	46.17	49.19	1.06
1B1B	0.0001	39.17	29.83	1.5480	46.18	53.54	1.16
1B2A	0.01	38.86	31.92	1.5412	49.20	56.28	1.14
1B2B	0.01	39.10	31.92	1.5449	49.31	57.01	1.16
1B3A	0.10	38.86	34.06	1.5372	52.36	64.78	1.24
1B3B	0.10	38.96	34.06	1.5340	52.25	60.87	1.16
1C1A	0.0001	52.69	29.83	1.8135	54.10	56.76	1.05
1C1B	0.0001	52.96	29.83	1.8122	54.06	56.52	1.05
1C2A	0.01	52.20	31.92	1.7977	57.38	61.02	1.06
1C2B	0.01	53.06	31.92	1.8000	57.46	64.58	1.12
1C3A	0.10	53.15	34.06	1.7875	60.88	73.96	1.21
1C3B	0.10	53.39	34.06	1.7840	60.76	69.27	1.14
1D1A	0.0001	100.68	29.83	2.1169	63.15	63.85	1.01
1D1B	0.0001	100.35	29.83	2.1210	63.27	63.90	1.01
1D2A	0.01	100.49	31.92	2.0943	66.85	70.35	1.05
1D2B	0.01	100.62	31.92	2.0945	66.86	69.22	1.04
1D3A	0.05	100.85	33.34	2.0792	69.32	74.06	1.07
1D3B	0.05	100.72	33.34	2.0791	69.32	72.45	1.05
Mean							1.148
Standard Deviation							0.105

Table 3.4(a)

Comparison of Computed and Tested Failure Loads Based on the  
 Effective Width Formulas in the 1986 AISI Automotive Steel  
 Design Manual for Stub Columns with Stiffened Flanges  
 (50XF Sheet Steel)  
 (Based on Static Compressive Yield Stress)

Spec.	Strain Rate (in./in./sec.)	w/t	$(F_y)_c$ (ksi)	$A_e$ (in. <sup>2</sup> )	$(P_u)_{comp}$ (kips)	$(P_u)_{test}$ (kips)	$\frac{(6)}{(5)}$ (7)
	(1)	(2)	(3)	(4)	(5)	(6)	(7)
1A1AX	0.0001	22.89	49.68	1.1569	57.47	57.89	1.01
1A1BX	0.0001	23.15	49.68	1.1652	57.89	57.65	1.00
1A2AX	0.01	23.15	49.68	1.1584	57.55	59.82	1.02
1A2BX	0.01	22.94	49.68	1.1587	57.56	60.23	1.05
1A3AX	0.05	23.10	49.68	1.1605	57.66	63.95	1.11
1A3BX	0.05	22.92	49.68	1.1612	57.69	62.04	1.08
1B1AX	0.0001	35.49	49.68	1.2783	63.50	62.19	0.98
1B1BX	0.0001	34.59	49.68	1.2785	63.51	61.75	0.97
1B2AX	0.01	34.50	49.68	1.2774	63.46	68.88	1.09
1B2BX	0.01	34.96	49.68	1.2798	63.57	67.86	1.07
1B3AX	0.04	34.97	49.68	1.2790	63.54	71.42	1.12
1B3BX	0.04	34.79	49.68	1.2809	63.64	71.52	1.12
1C1AX	0.0001	52.76	49.68	1.3299	66.07	60.09	0.91
1C1BX	0.0001	53.40	49.68	1.3336	66.25	60.67	0.92
1C2AX	0.01	53.06	49.68	1.3323	66.19	64.00	0.97
1C2BX	0.01	52.23	49.68	1.3316	66.15	66.44	1.00
1C3AX	0.04	51.67	49.68	1.3292	66.03	66.54	1.01
1C3BX	0.04	52.90	49.68	1.3336	66.25	69.47	1.05
1D1AX	0.0001	97.99	49.68	1.6385	81.40	76.94	0.95
1D2AX	0.01	98.21	49.68	1.6371	81.33	82.22	1.01
1D3AX	0.03	98.01	49.68	1.6416	81.56	82.46	1.01
1D3BX	0.03	98.07	49.68	1.6423	81.59	80.85	0.99
Mean							1.020
Standard Deviation							0.061

Table 3.4(b)

Comparison of Computed and Tested Failure Loads Based on the  
Effective Width Formulas in the 1986 AISI Automotive Steel  
Design Manual for Stub Columns with Stiffened Flanges  
(50XF Sheet Steel)  
(Based on Dynamic Compressive Yield Stress)

Spec.	Strain Rate (in./in./sec.)	w/t	(F <sub>y</sub> ) <sub>c</sub> (ksi)	A <sub>e</sub> (in. <sup>2</sup> )	(P <sub>u</sub> ) <sub>comp</sub> (kips)	(P <sub>u</sub> ) <sub>test</sub> (kips)	$\frac{(6)}{(5)}$ (7)
	(1)	(2)	(3)	(4)	(5)	(6)	(7)
1A1AX	0.0001	22.89	49.68	1.1569	57.47	57.89	1.01
1A1BX	0.0001	23.15	49.68	1.1652	57.89	57.65	1.00
1A2AX	0.01	23.15	52.51	1.1584	60.83	59.82	0.98
1A2BX	0.01	22.94	52.51	1.1587	60.84	60.23	0.99
1A3AX	0.05	23.10	53.37	1.1605	61.94	63.95	1.03
1A3BX	0.05	22.92	53.37	1.1612	61.97	62.04	1.00
1B1AX	0.0001	35.49	49.68	1.2783	63.50	62.19	0.98
1B1BX	0.0001	34.59	49.68	1.2785	63.51	61.75	0.97
1B2AX	0.01	34.50	52.51	1.2712	66.75	68.88	1.03
1B2BX	0.01	34.96	52.51	1.2736	66.87	67.86	1.01
1B3AX	0.04	34.97	53.25	1.2710	67.68	71.42	1.06
1B3BX	0.04	34.79	53.25	1.2730	67.79	71.52	1.06
1C1AX	0.0001	52.76	49.68	1.3299	66.07	60.09	0.91
1C1BX	0.0001	53.40	49.68	1.3336	66.25	60.67	0.92
1C2AX	0.01	53.06	52.51	1.3323	69.74	64.00	0.92
1C2BX	0.01	52.23	52.51	1.3223	69.44	66.44	0.96
1C3AX	0.04	51.67	53.25	1.3182	70.17	66.54	0.95
1C3BX	0.04	52.90	53.25	1.3219	70.39	69.47	0.99
1D1AX	0.0001	97.99	49.68	1.6388	81.40	76.94	0.95
1D2AX	0.01	98.21	52.51	1.6254	85.34	82.22	0.96
1D3AX	0.03	98.01	53.10	1.6273	86.41	82.46	0.95
1D3BX	0.03	98.07	53.10	1.6279	86.44	80.85	0.94
Mean							0.981
Standard Deviation							0.044

Table 3.5

Average Tested Failure Loads for Stub Column  
Specimens with Stiffened Flanges  
(35XF Sheet Steel)

Strain Rate in./in./sec.	w/t			
		27.21	38.98	52.91
0.0001	45.51	51.37	56.64	63.88
0.01	49.66	56.65	62.80	69.79
0.05				73.26
0.1	53.96	62.83	71.62	

Table 3.6

Average Tested Failure Loads for Stub Column  
Specimens with Stiffened Flanges  
(50XF Sheet Steel)

Strain Rate in./in./sec.	w/t			
		23.03	34.88	52.67
0.0001	57.77	61.97	60.37	76.94
0.01	60.03	68.37	65.22	82.22
0.03				82.46
0.04		71.47	68.01	
0.05	63.00			

Table 3.7

Comparison of Computed and Tested Critical Buckling Loads  
Stub Columns with Unstiffened Flanges (Based on  $k=0.43$ )  
(35XF Sheet Steel)

Specimen	$(f_{cr})_{comp}$	$(P_{cr})_{comp}$	$(P_{cr})_{test}$	(3)
	(ksi)	(kips)	(kips)	(2)
	(1)	(2)	(3)	(4)
2A1A	28.34	17.63	N/A	N/A
2A1B	28.30	17.79	N/A	N/A
2A2A	30.26	19.03	N/A	N/A
2A2B	30.20	18.95	N/A	N/A
2A3A	32.17	20.23	N/A	N/A
2A3B	32.16	20.11	N/A	N/A
2B1A	26.50	24.48	N/A	N/A
2B1B	26.47	24.31	N/A	N/A
2B2A	28.19	25.91	N/A	N/A
2B2B	28.21	26.00	N/A	N/A
2B3A	29.85	27.55	N/A	N/A
2B3B	29.80	27.50	N/A	N/A
2C0A	21.81	24.69	35.42	1.434
2C1A	21.71	24.59	36.44	1.482
2C1B	21.78	24.77	36.44	1.471
2C2A	22.78	25.85	40.40	1.563
2C2B	22.92	26.08	40.35	1.547
2C3A	23.70	26.87	46.95	1.747
2C3B	23.76	26.92	44.38	1.648
2D1A	5.764	10.80	20.27	1.877
2D1B	5.789	10.84	21.84	2.015
2D2A	5.758	10.77	17.05	1.583
2D2B	5.767	10.80	22.86	2.117
2D3A	5.786	10.77	21.40	1.987
2D3B	5.764	10.80	15.39	1.425
Mean				1.684
Standard Deviation				0.240

Table 3.8

Comparison of Computed and Tested Critical Buckling Loads  
Stub Columns with Unstiffened Flanges (Based on  $k=0.43$ )  
(50XF Sheet Steel)

Specimen	$(f_{cr})_{comp}$	$(P_{cr})_{comp}$	$(P_{cr})_{test}$	$\frac{(3)}{(2)}$
	(ksi)	(kips)	(kips)	(2)
	(1)	(2)	(3)	(4)
2A1AX	46.86	24.45	N/A	N/A
2A1BX	47.00	24.56	N/A	N/A
2A2AX	49.43	25.84	N/A	N/A
2A2BX	49.44	25.83	N/A	N/A
2A3AX	50.34	26.34	N/A	N/A
2A3BX	50.31	26.29	N/A	N/A
2B1AX	44.60	33.69	N/A	N/A
2B1BX	44.63	33.84	N/A	N/A
2B1CX	43.76	33.23	N/A	N/A
2B2AX	46.67	35.42	N/A	N/A
2B2BX	46.72	35.58	N/A	N/A
2B2CX	46.00	34.77	N/A	N/A
2B3AX	47.18	35.79	N/A	N/A
2B3BX	47.34	35.80	N/A	N/A
2C1AX	21.79	22.69	33.51	1.48
2C1BX	22.19	22.93	36.82	1.61
2C2AX	22.11	22.81	37.42	1.64
2C2BX	22.13	22.86	33.07	1.45
2C3AX	22.20	22.86	29.26	1.28
2C3BX	22.07	22.81	22.37	0.98
2D1AX	9.16	11.72	23.21	1.98
2D1BX	9.18	11.74	21.51	1.83
2D2AX	9.22	11.78	22.56	1.92
2D2BX	9.24	11.80	22.62	1.92
2D3AX	9.21	11.76	22.57	1.92
2D3BX	9.28	11.84	11.92	1.01
Mean				1.585
Standard Deviation				0.354

Table 3.9(a)

Comparison of Computed and Tested Failure Loads Based on the  
Effective Width Formulas in the 1986 AISI Automotive Steel  
Design Manual for Stub Columns with Unstiffened Flanges  
(35XF Sheet Steel)  
(Based on Static Compressive Yield Stress)

Spec.	Strain Rate (in./in./sec.)	w/t	(F <sub>y</sub> ) <sub>c</sub> (ksi)	A <sub>e</sub> (in. <sup>2</sup> )	(P <sub>u</sub> ) <sub>comp</sub> (kips)	(P <sub>u</sub> ) <sub>test</sub> (kips)	$\frac{(6)}{(5)}$ (7)
2A1A	0.0001	8.93	29.83	.6220	18.55	25.26	1.36
2A1B	0.0001	9.04	29.83	.6285	18.75	25.35	1.35
2A2A	0.01	8.93	29.83	.6288	18.76	26.04	1.39
2A2B	0.01	9.10	29.83	.6275	18.72	27.70	1.48
2A3A	0.10	8.93	29.83	.6288	18.76	31.41	1.67
2A3B	0.10	8.96	29.83	.6254	18.65	29.41	1.58
2B1A	0.0001	13.34	29.83	.9216	27.49	34.20	1.24
2B1B	0.0001	13.41	29.83	.9151	27.30	34.20	1.25
2B2A	0.01	13.40	29.83	.9160	27.32	36.30	1.33
2B2B	0.01	13.37	29.83	.9191	27.42	37.52	1.37
2B3A	0.10	13.34	29.83	.9208	27.47	41.67	1.52
2B3B	0.10	13.42	29.83	.9195	27.43	42.70	1.56
2C0A	0.00001	20.69	29.83	.9825	29.31	36.30	1.24
2C1A	0.0001	20.85	29.83	.9793	29.21	37.23	1.27
2C1B	0.0001	20.76	29.83	.9860	29.41	37.66	1.28
2C2A	0.01	20.97	29.83	.9785	29.19	41.28	1.41
2C2B	0.01	20.81	29.83	.9857	29.40	41.52	1.41
2C3A	0.10	20.93	29.83	.9787	29.19	47.92	1.64
2C3B	0.10	20.87	29.83	.9796	29.22	46.16	1.58
2D1A	0.0001	44.60	29.83	1.0971	32.73	41.72	1.27
2D1B	0.0001	44.50	29.83	1.0985	32.77	41.04	1.25
2D2A	0.01	44.62	29.83	1.0931	32.61	46.31	1.42
2D2B	0.01	44.59	29.83	1.0949	32.66	44.94	1.38
2D3A	0.05	44.51	29.83	1.0867	32.41	48.66	1.50
2D3B	0.05	44.60	29.83	1.0970	32.72	49.39	1.51
Mean							1.410
Standard Deviation							0.132

Table 3.9(b)

Comparison of Computed and Tested Failure Loads Based on the  
Effective Width Formulas in the 1986 AISI Automotive Steel  
Design Manual for Stub Columns with Unstiffened Flanges  
(35XF Sheet Steel)  
(Based on Dynamic Compressive Yield Stress)

Spec.	Strain Rate (in./in./sec.)	w/t	(F <sub>y</sub> ) <sub>c</sub> (ksi)	A <sub>e</sub> (in. <sup>2</sup> )	(P <sub>u</sub> ) <sub>comp</sub> (kips)	(P <sub>u</sub> ) <sub>test</sub> (kips)	$\frac{(6)}{(5)}$ (7)
	(1)	(2)	(3)	(4)	(5)	(6)	(7)
2A1A	0.0001	8.93	29.83	.6220	18.55	25.26	1.36
2A1B	0.0001	9.04	29.83	.6285	18.75	25.35	1.35
2A2A	0.01	8.93	31.92	.6288	20.07	26.04	1.30
2A2B	0.01	9.10	31.92	.6275	20.03	27.70	1.38
2A3A	0.10	8.93	34.06	.6288	21.42	31.41	1.47
2A3B	0.10	8.96	34.06	.6254	21.30	29.41	1.38
2B1A	0.0001	13.34	29.83	.9216	27.49	34.20	1.24
2B1B	0.0001	13.41	29.83	.9151	27.30	34.20	1.25
2B2A	0.01	13.40	31.92	.9091	29.02	36.30	1.25
2B2B	0.01	13.37	31.92	.9122	29.12	37.52	1.29
2B3A	0.10	13.34	34.06	.9069	30.89	41.67	1.35
2B3B	0.10	13.42	34.06	.9049	30.82	42.70	1.38
2C0A	0.00001	20.69	29.77	.9828	29.26	36.30	1.24
2C1A	0.0001	20.85	29.83	.9793	29.21	37.23	1.27
2C1B	0.0001	20.76	29.83	.9859	29.41	37.66	1.28
2C2A	0.01	20.97	31.92	.9672	30.87	41.28	1.34
2C2B	0.01	20.81	31.92	.9745	31.11	41.52	1.33
2C3A	0.10	20.93	34.06	.9587	32.65	47.92	1.47
2C3B	0.10	20.87	34.06	.9637	32.82	46.16	1.41
2D1A	0.0001	44.60	29.83	1.0971	32.73	41.72	1.27
2D1B	0.0001	44.50	29.83	1.0985	32.77	41.04	1.25
2D2A	0.01	44.62	31.92	1.0778	34.40	46.31	1.35
2D2B	0.01	44.59	31.92	1.0796	34.46	44.94	1.30
2D3A	0.05	44.51	33.34	1.0618	35.40	48.66	1.37
2D3B	0.05	44.60	33.34	1.0721	35.74	49.39	1.38
Mean							1.330
Standard Deviation							0.067



Table 3.10(a)

Comparison of Computed and Tested Failure Loads Based on the  
 Effective Width Formulas in the 1986 AISI Automotive Steel  
 Design Manual for Stub Columns with Unstiffened Flanges  
 (50XF Sheet Steel)  
 (Based on Static Compressive Yield Stress)

Spec.	Strain Rate (in./in./sec.)	w/t	(F <sub>y</sub> ) <sub>c</sub> (ksi)	A <sub>e</sub> (in. <sup>2</sup> )	(P <sub>u</sub> ) <sub>comp</sub> (kips)	(P <sub>u</sub> ) <sub>test</sub> (kips)	$\frac{(6)}{(5)}$ (7)
	(1)	(2)	(3)	(4)	(5)	(6)	(7)
2A1AX	0.0001	8.41	49.68	.5220	25.92	28.04	1.08
2A1BX	0.0001	8.38	49.68	.5227	25.96	28.16	1.09
2A2AX	0.01	8.40	49.68	.5228	25.98	29.02	1.12
2A2BX	0.01	8.38	49.68	.5224	25.95	29.43	1.13
2A3AX	0.08	8.29	49.68	.5232	25.99	30.75	1.18
2A3BX	0.08	8.36	49.68	.5227	25.96	30.95	1.19
2B1AX	0.0001	11.68	49.68	.7354	36.54	39.72	1.09
2B1BX	0.0001	11.60	49.68	.7395	36.74	39.18	1.07
2B1CX	0.00001	11.63	49.68	.7402	36.77	39.47	1.07
2B2AX	0.01	11.58	49.68	.7405	36.79	42.60	1.16
2B2BX	0.01	11.54	49.68	.7438	36.95	42.55	1.15
2B2CX	0.001	11.53	49.68	.7382	36.67	41.77	1.14
2B3AX	0.08	11.65	49.68	.7391	36.72	45.07	1.23
2B3BX	0.08	11.50	49.68	.7391	36.72	44.94	1.22
2C1AX	0.0001	22.84	49.68	.7985	39.67	43.62	1.10
2C1BX	0.0001	22.73	49.68	.8015	39.82	43.97	1.10
2C2AX	0.01	22.77	49.68	.7989	39.69	46.70	1.18
2C2BX	0.01	22.76	49.68	.8004	39.77	46.26	1.16
2C3AX	0.05	22.72	49.68	.7979	39.64	47.34	1.19
2C3BX	0.05	22.79	49.68	.8002	39.75	46.85	1.18
2D1AX	0.0001	35.37	49.68	.7669	38.10	44.06	1.16
2D1BX	0.0001	35.33	49.68	.7668	38.10	44.50	1.17
2D2AX	0.01	35.26	49.68	.7672	38.11	46.75	1.23
2D2BX	0.01	35.21	49.68	.7676	38.14	47.58	1.25
2D3AX	0.04	35.29	49.68	.7666	38.09	49.39	1.30
2D3BX	0.04	35.15	49.68	.7679	38.15	48.95	1.28
Mean							1.162
Standard Deviation							0.064

Table 3.10(b)

Comparison of Computed and Tested Failure Loads Based on the  
 Effective Width Formulas in the 1986 AISI Automotive Steel  
 Design Manual for Stub Columns with Unstiffened Flanges  
 (50XF Sheet Steel)  
 (Based on Dynamic Compressive Yield Stress)

Spec.	Strain Rate (in./in./sec.)	w/t	(F <sub>y</sub> ) <sub>c</sub> (ksi)	A <sub>e</sub> (in. <sup>2</sup> )	(P <sub>u</sub> ) <sub>comp</sub> (kips)	(P <sub>u</sub> ) <sub>test</sub> (kips)	$\frac{(6)}{(5)}$ (7)
2A1AX	0.0001	8.41	49.68	.5220	25.92	28.04	1.08
2A1BX	0.0001	8.38	49.68	.5227	25.96	28.16	1.09
2A2AX	0.01	8.40	52.51	.5228	27.45	29.02	1.06
2A2BX	0.01	8.38	52.51	.5224	27.43	29.43	1.07
2A3AX	0.08	8.29	53.61	.5232	28.05	30.75	1.10
2A3BX	0.08	8.36	53.61	.5227	28.02	30.95	1.10
2B1AX	0.0001	11.68	49.68	.7354	36.54	39.72	1.09
2B1BX	0.0001	11.60	49.68	.7397	36.74	39.18	1.07
2B1CX	0.00001	11.63	48.06	.7415	35.69	39.47	1.10
2B2AX	0.01	11.58	52.51	.7363	38.66	42.60	1.10
2B2BX	0.01	11.54	52.51	.7399	38.84	42.55	1.10
2B2CX	0.001	11.53	51.16	.7347	37.65	41.77	1.11
2B3AX	0.08	11.65	53.61	.7333	39.31	45.07	1.15
2B3BX	0.08	11.50	53.61	.7333	39.31	44.94	1.14
2C1AX	0.0001	22.84	49.68	.7991	39.67	43.62	1.10
2C1BX	0.0001	22.73	49.68	.8015	39.82	43.97	1.10
2C2AX	0.01	22.77	52.51	.7919	41.58	46.70	1.12
2C2BX	0.01	22.76	52.51	.7936	41.66	46.26	1.11
2C3AX	0.05	22.72	53.37	.7891	42.10	47.34	1.12
2C3BX	0.05	22.79	53.37	.7909	42.23	46.85	1.11
2D1AX	0.0001	35.37	49.68	.7669	38.10	44.06	1.16
2D1BX	0.0001	35.33	49.68	.7668	38.10	44.50	1.17
2D2AX	0.01	35.26	52.51	.7592	39.87	46.75	1.17
2D2BX	0.01	35.21	52.51	.7596	39.89	47.58	1.19
2D3AX	0.04	35.29	53.25	.7566	40.29	49.39	1.23
2D3BX	0.04	35.15	53.25	.7576	40.36	48.95	1.21
Mean							1.121
Standard Deviation							0.044

Table 3.11

Average Tested Failure Loads for Stub Column  
Specimens with Unstiffened Flanges  
(35XF Sheet Steel)

Strain Rate in./in./sec.	w/t			
	8.98	13.38	20.87	44.57
0.0001	25.31	34.20	37.45	41.38
0.01	26.87	36.91	41.40	45.63
0.05				49.03
0.1	30.41	42.19	47.04	

Table 3.12

Average Tested Failure Loads for Stub Column  
Specimens with Unstiffened Flanges  
(50XF Sheet Steel)

Strain Rate in./in./sec.	w/t			
	8.37	11.59	22.77	35.27
0.0001	28.10	39.45	43.80	44.28
0.01	29.23	42.58	46.48	47.17
0.04				49.17
0.05			47.10	
0.08	30.85	45.01		

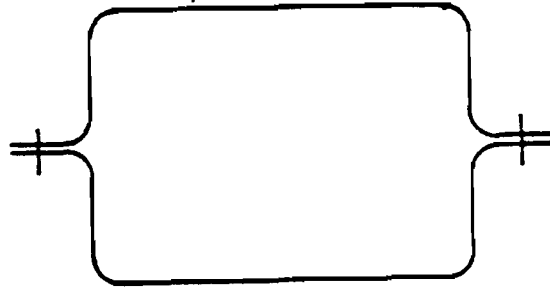

Figure 2.1 Configuration of Test Specimens for Members Having Stiffened Compression Flanges

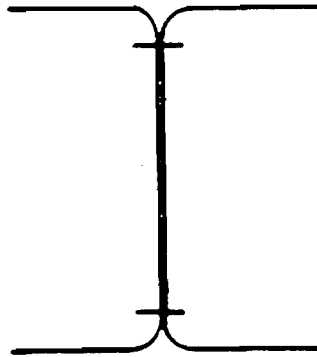

Figure 2.1 Configuration of Test Specimens for Members Having Unstiffened Compression Flanges

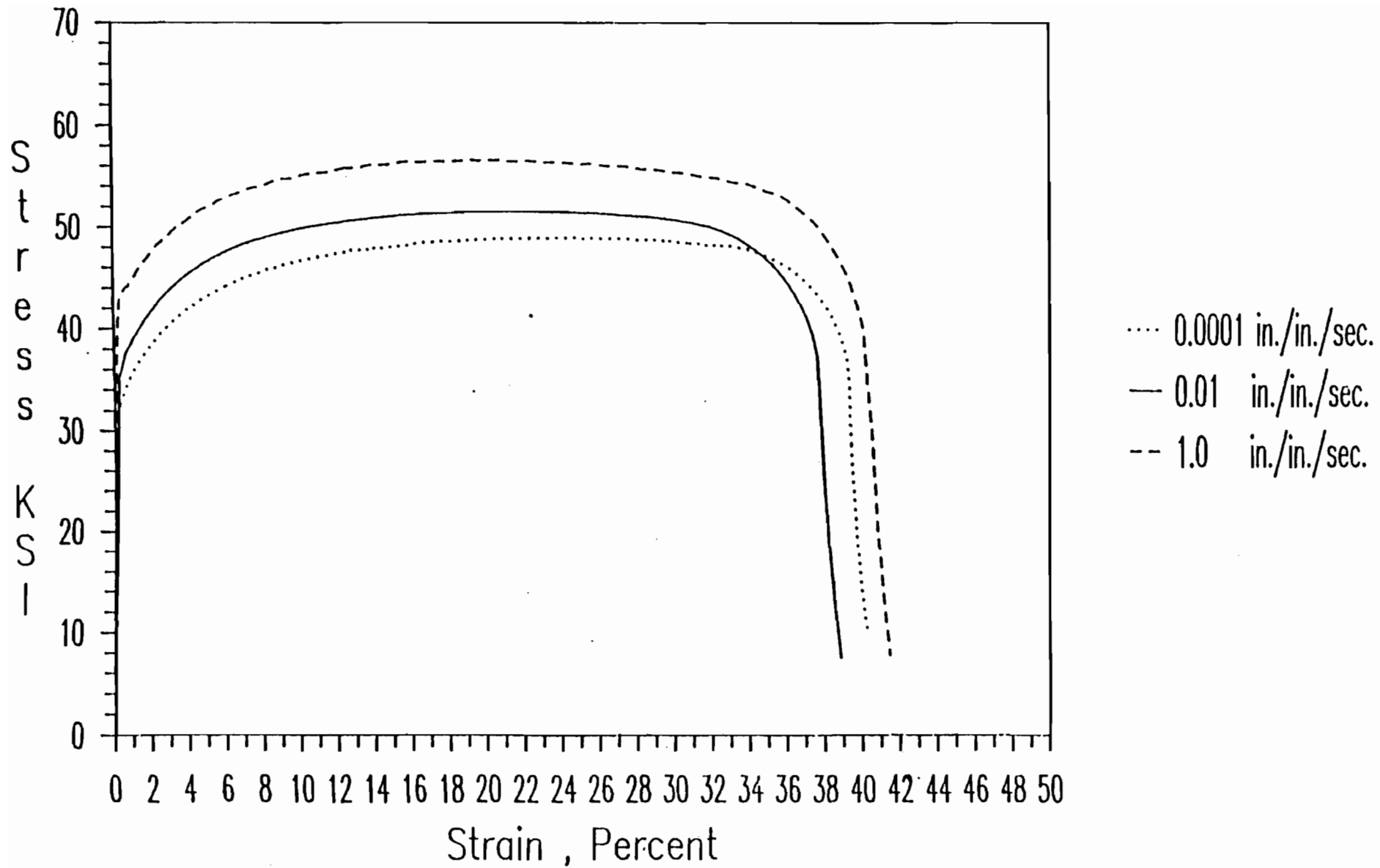

Figure 2.3 Stress-Strain Curves for 35XF Sheet Steel Tested Under Different Strain Rates (Longitudinal Tension)

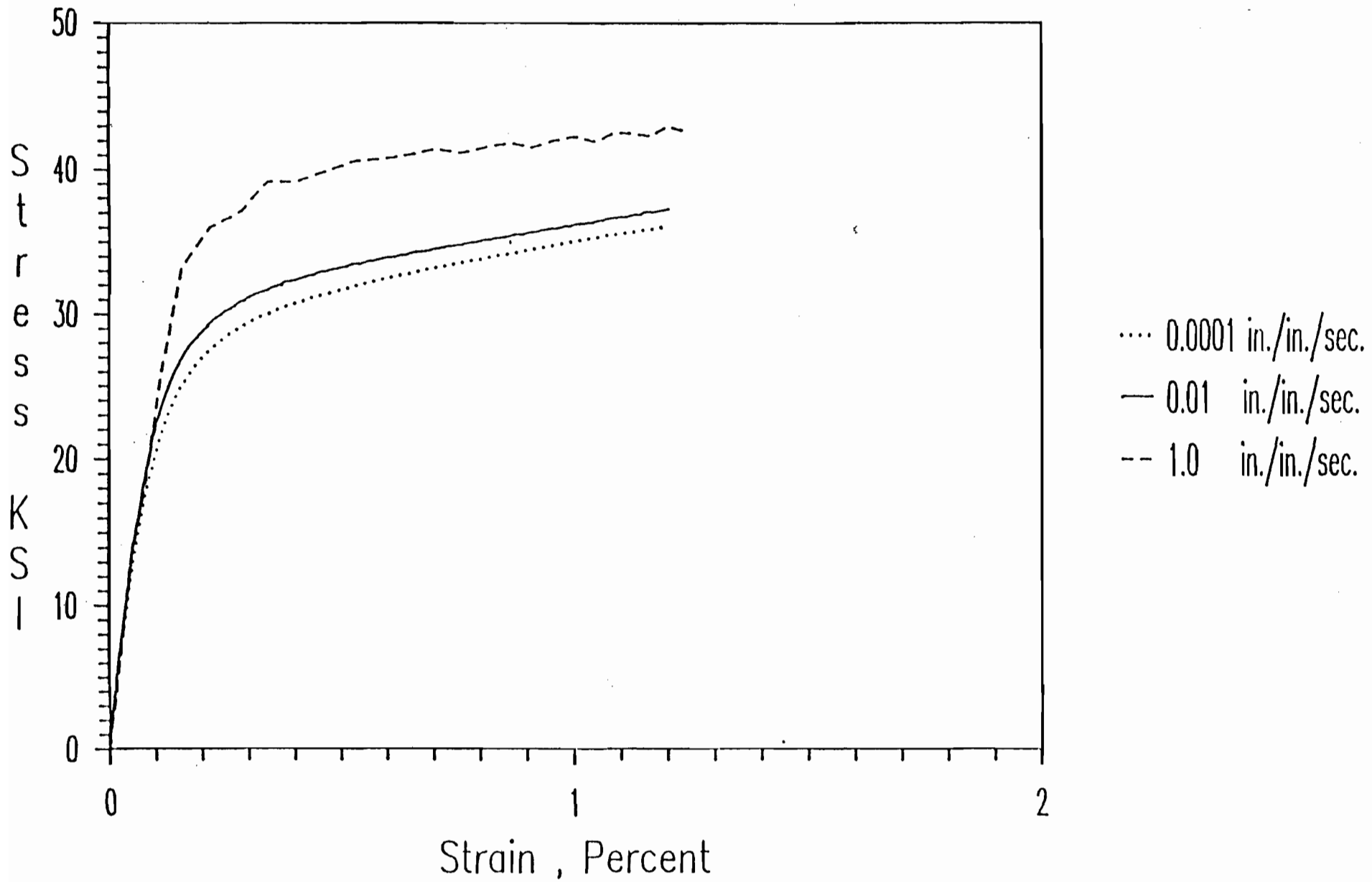

Figure 2.4 Stress-Strain Curves for 35XF Sheet Steel Tested Under Different Strain Rates (Longitudinal Compression)

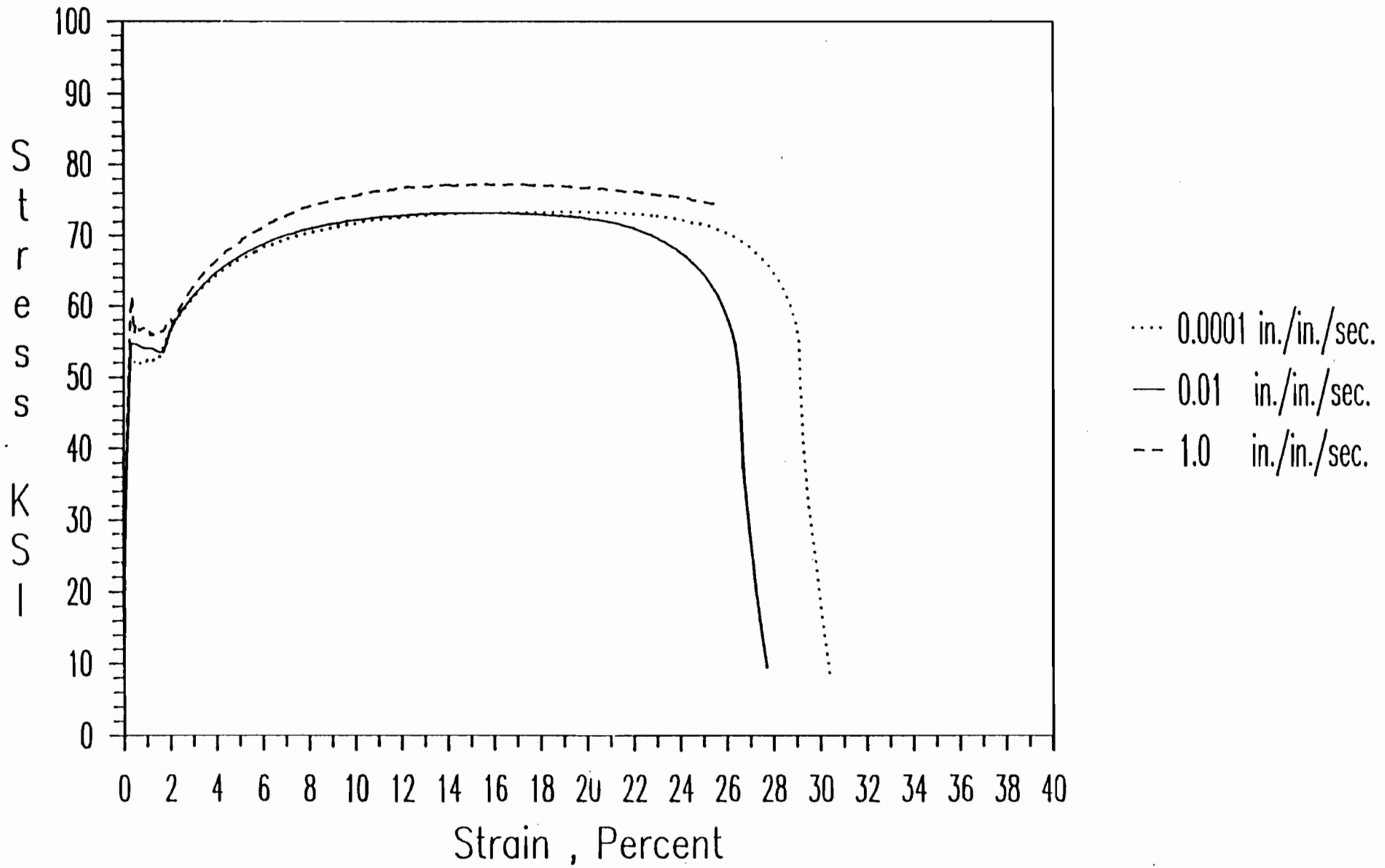

Figure 2.5 Stress-Strain Curves for 50XF Sheet Steel Tested Under Different Strain Rates (Longitudinal Tension)

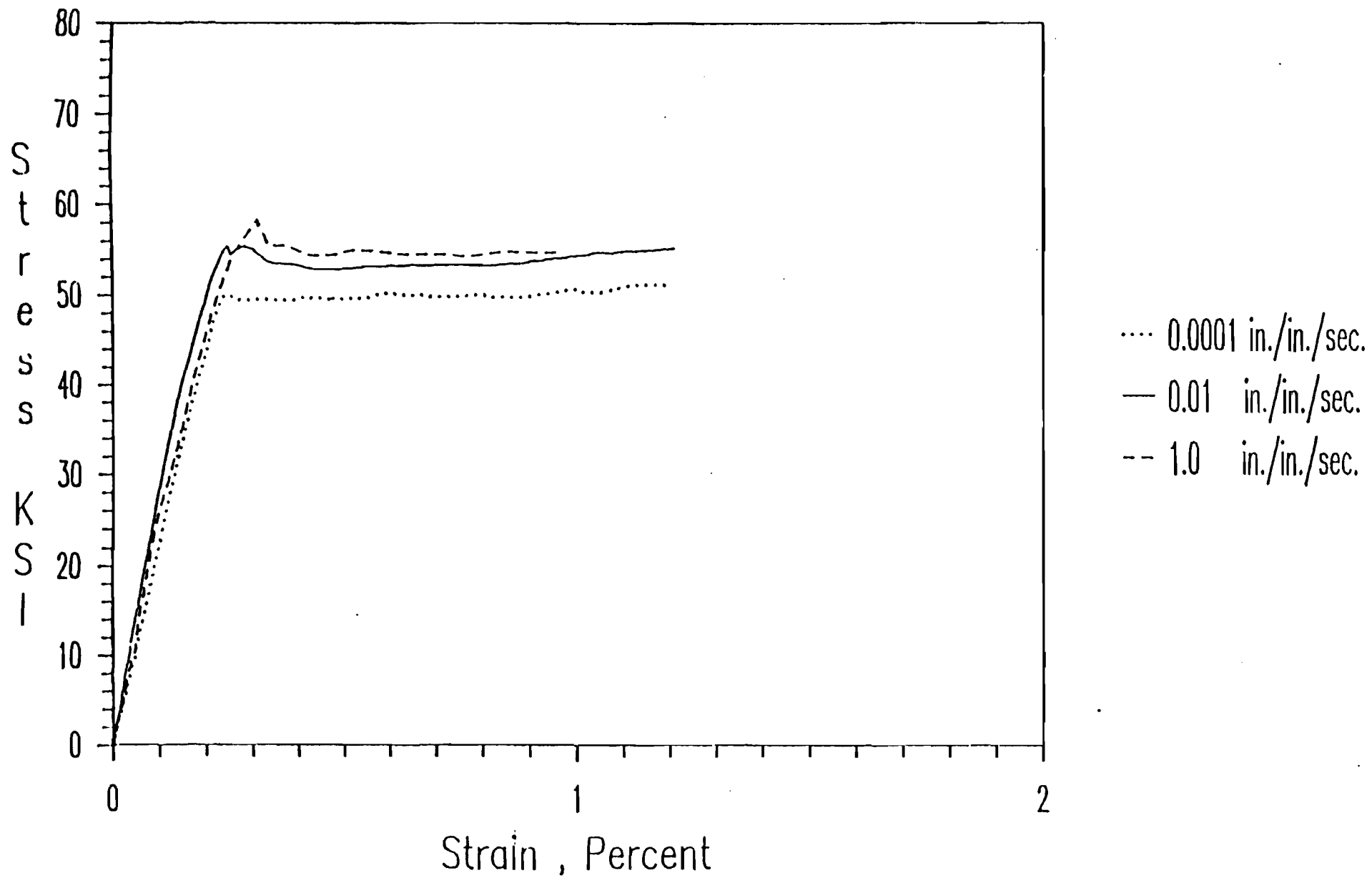

Figure 2.6 Stress-Strain Curves for 50XF Sheet Steel Tested Under Different Strain Rates (Longitudinal Compression)



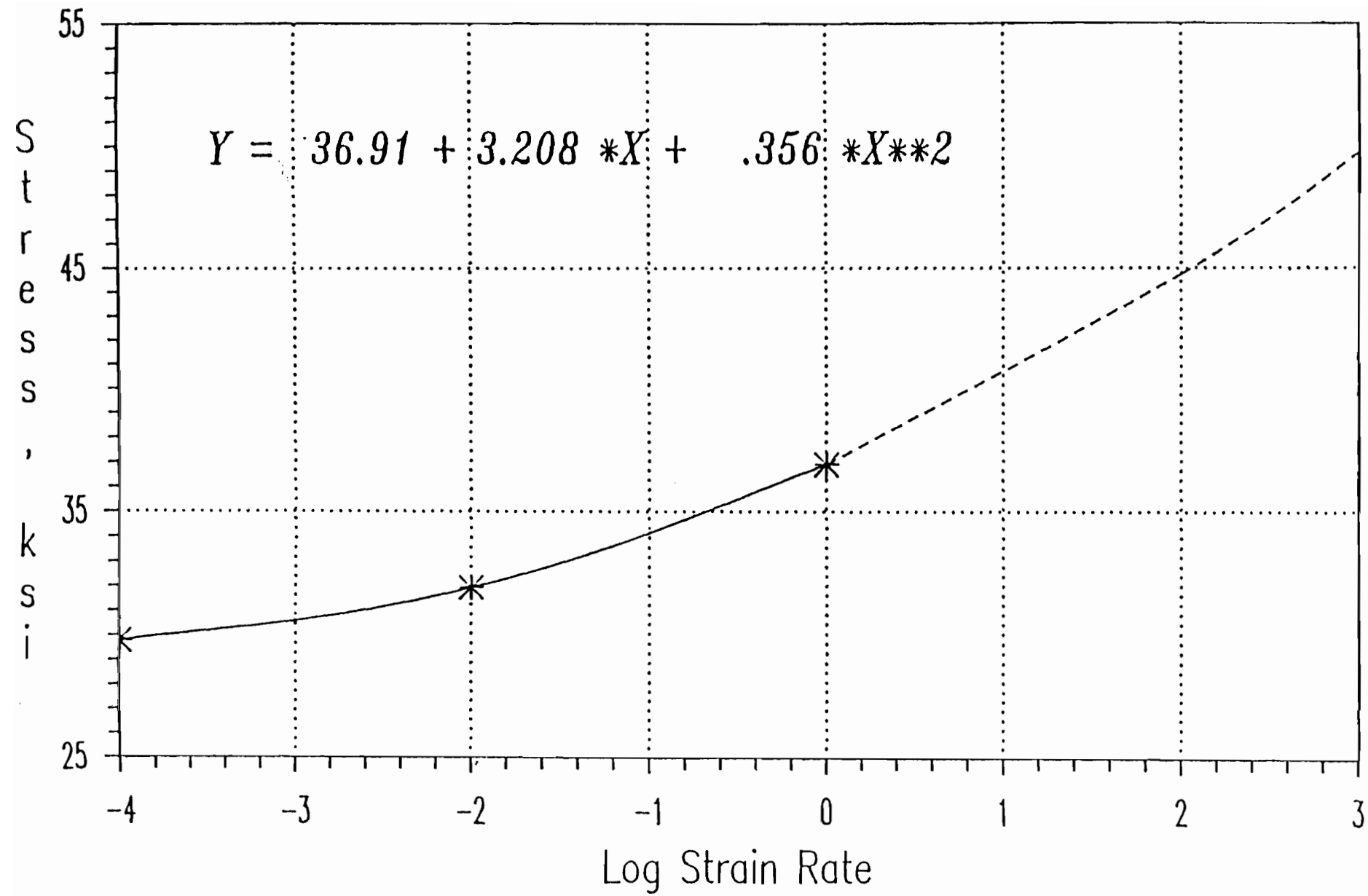

Figure 2.7 Compressive Yield Stress vs. Logarithmic Strain-Rate Curve for 35XF Steel (Longitudinal Compression)

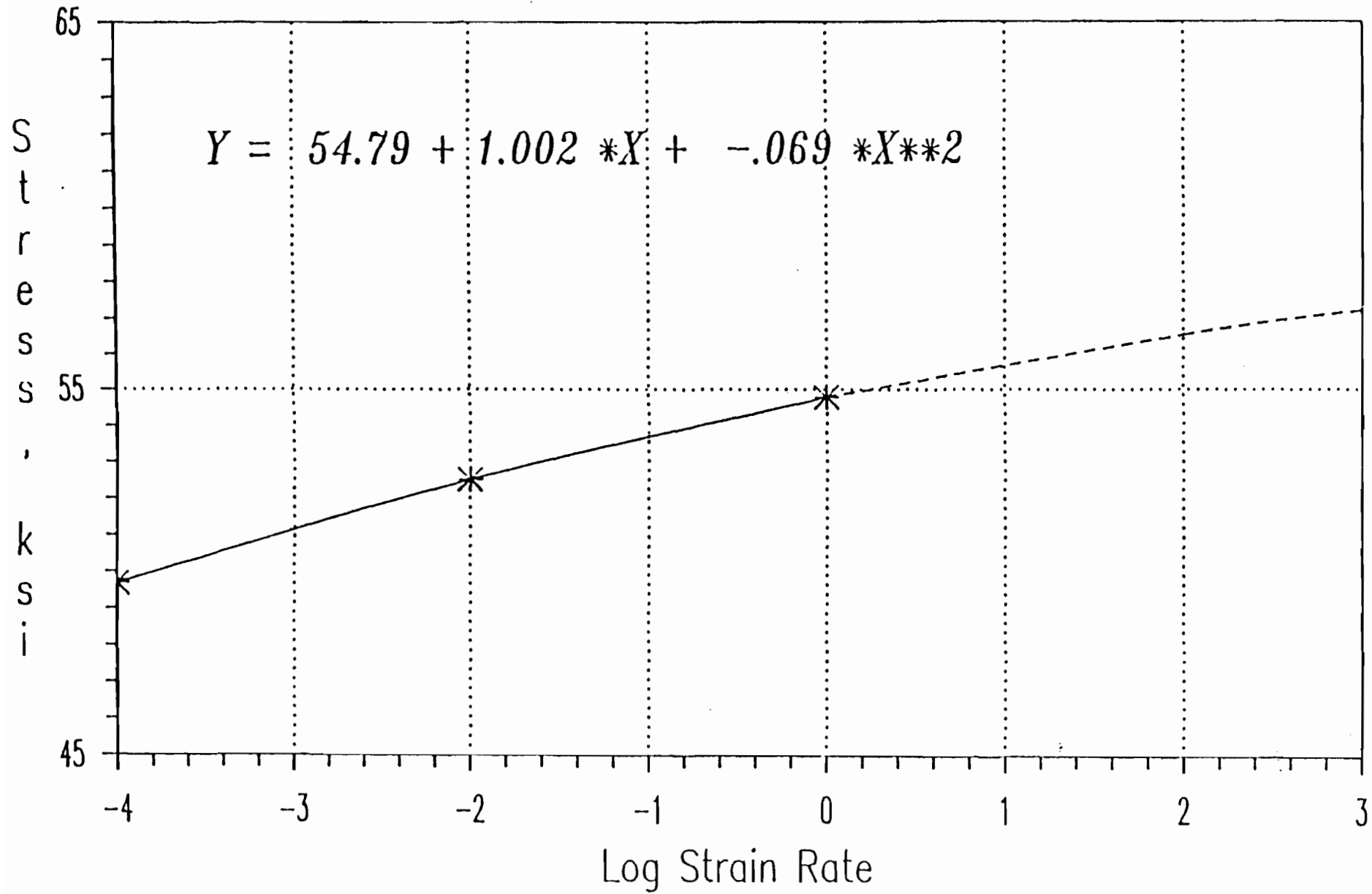

Figure 2.8 Compressive Yield Stress vs. Logarithmic Strain-Rate Curve for 50XF Steel (Longitudinal Compression)

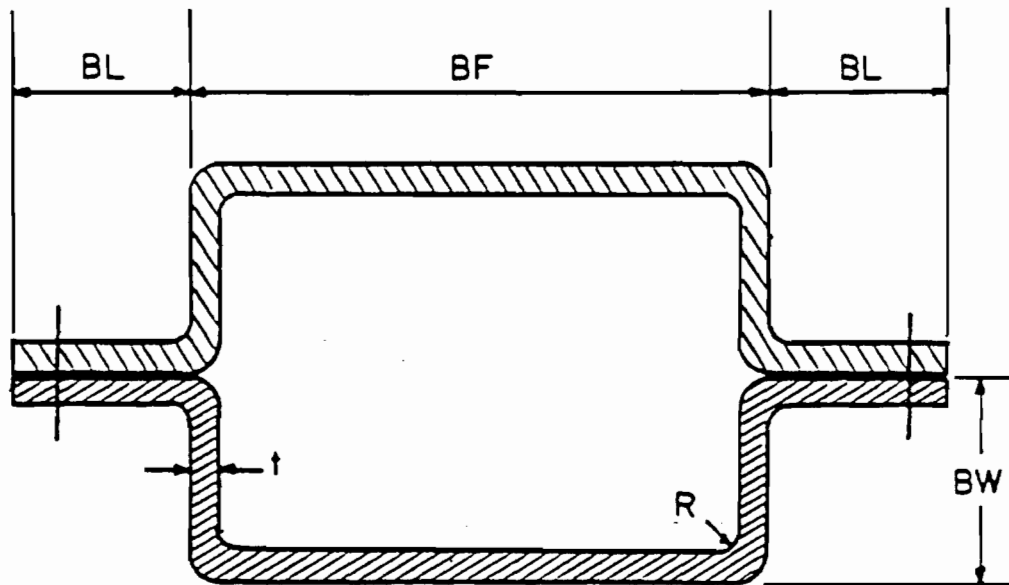

Figure 2.9 Cross Section of Box-Shaped Stub Columns Used for the Study of Stiffened Elements

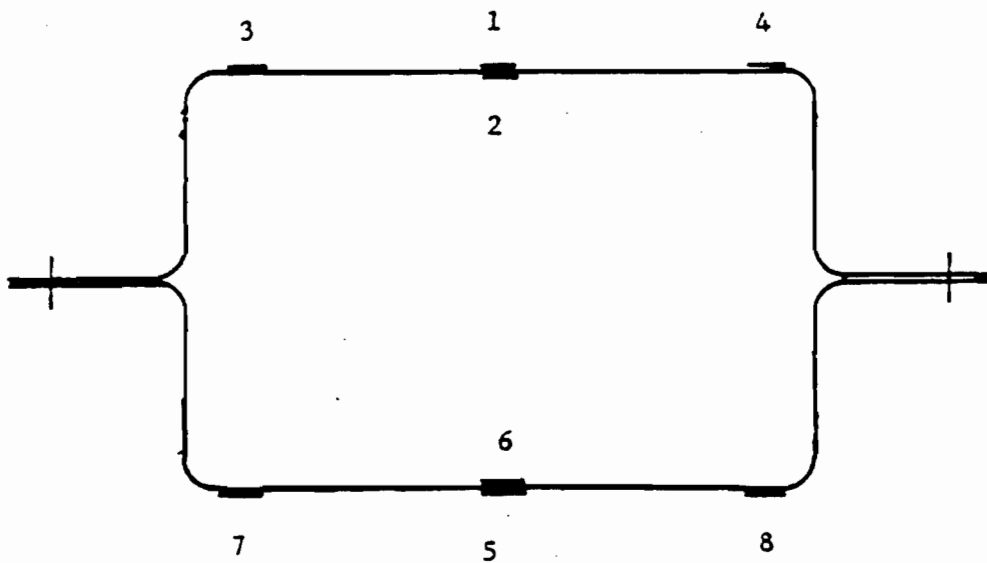

Figure 2.10 Locations of Strain Gages at Midheight of Box-Shaped Stub Columns

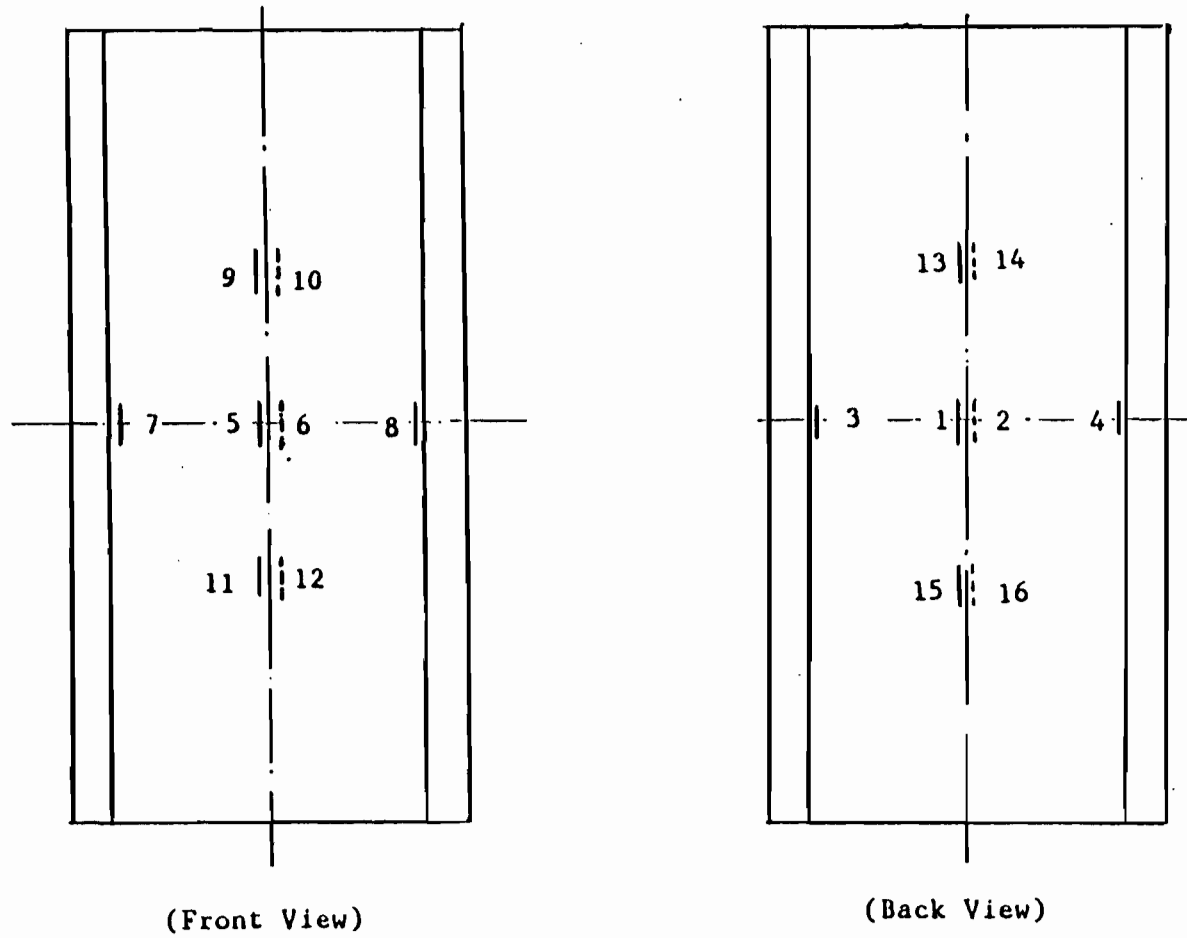

Figure 2.11 Locations of Strain Gages along the Specimen Length for Box-Shaped Stub Columns Having Large  $w/t$  Ratios



Figure 2.12 MTS 880 Material Test System and CAMAC Data Acquisition  
Used for Stub Column Tests

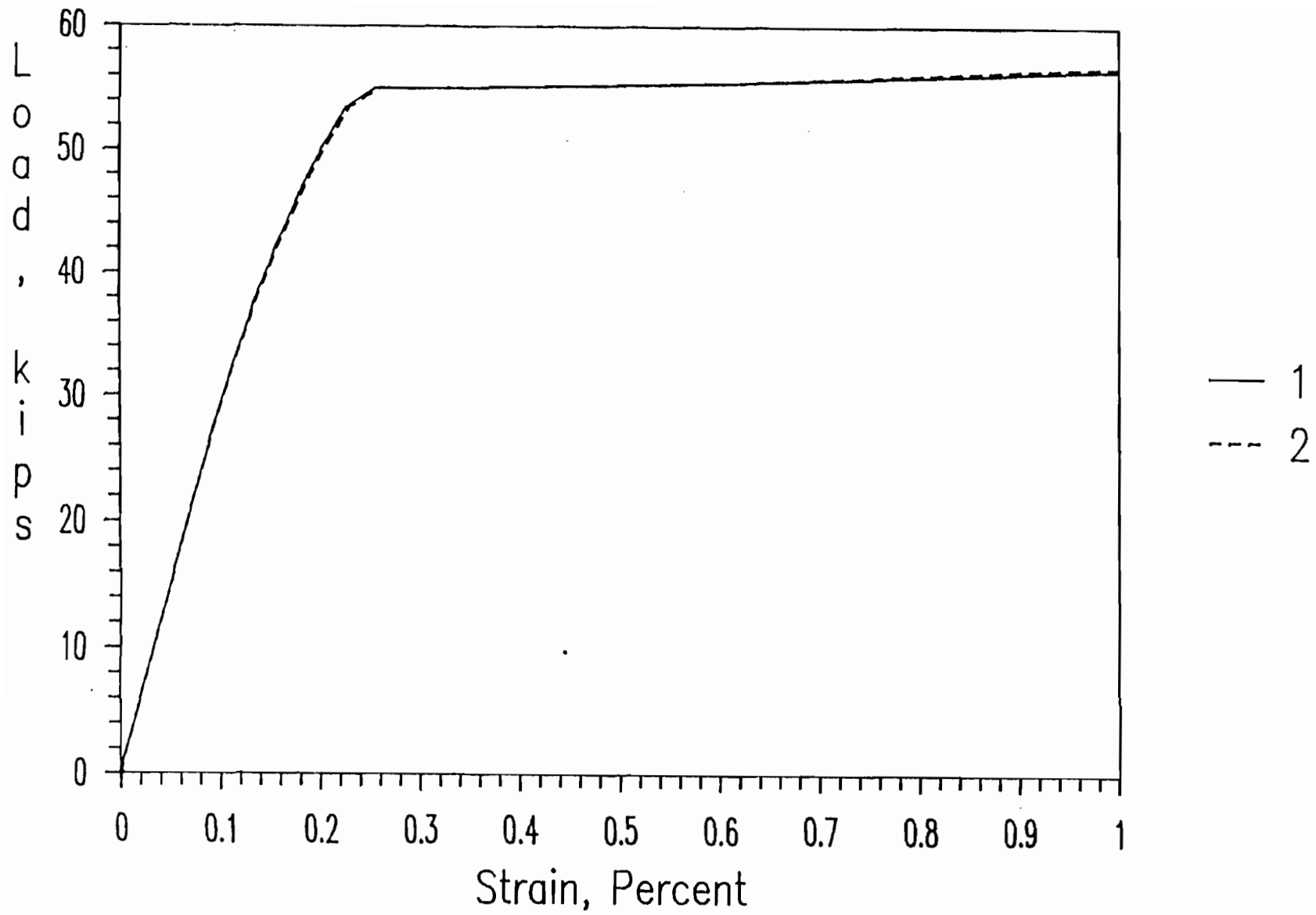

Figure 2.13 Load-Strain Curves of Strain Gages # 1 and 2 Installed at the Center of Stiffened Elements (Spec. 1A1AX)

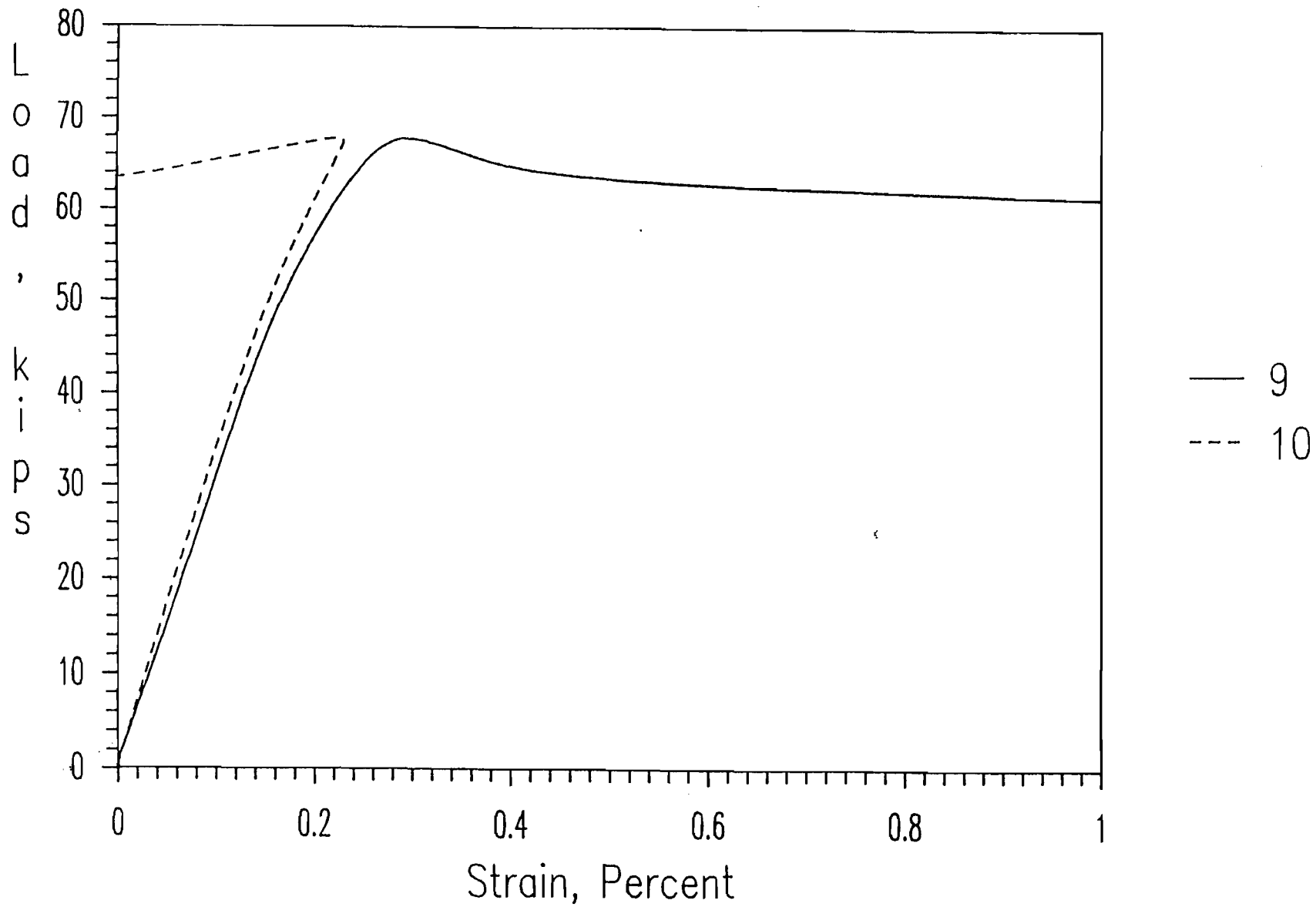

Figure 2.14 Load-Strain Curves of Strain Gages # 9 and 10 Installed at the Center of Stiffened Elements (Spec. 1B2BX)

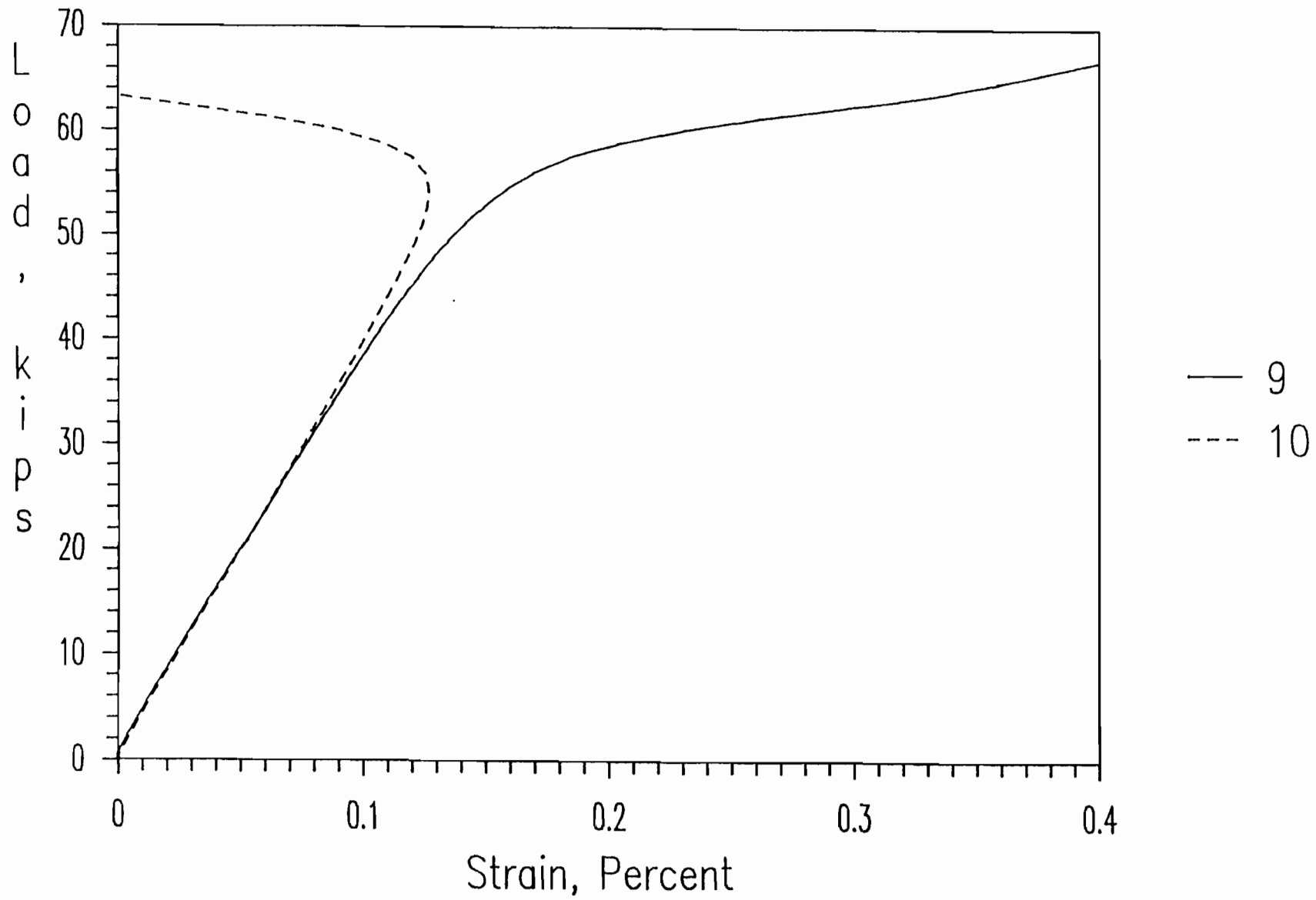

Figure 2.15 Load-Strain Curves of Strain Gages # 9 and 10 Installed at the Center of Stiffened Elements (Spec. 1C3BX)



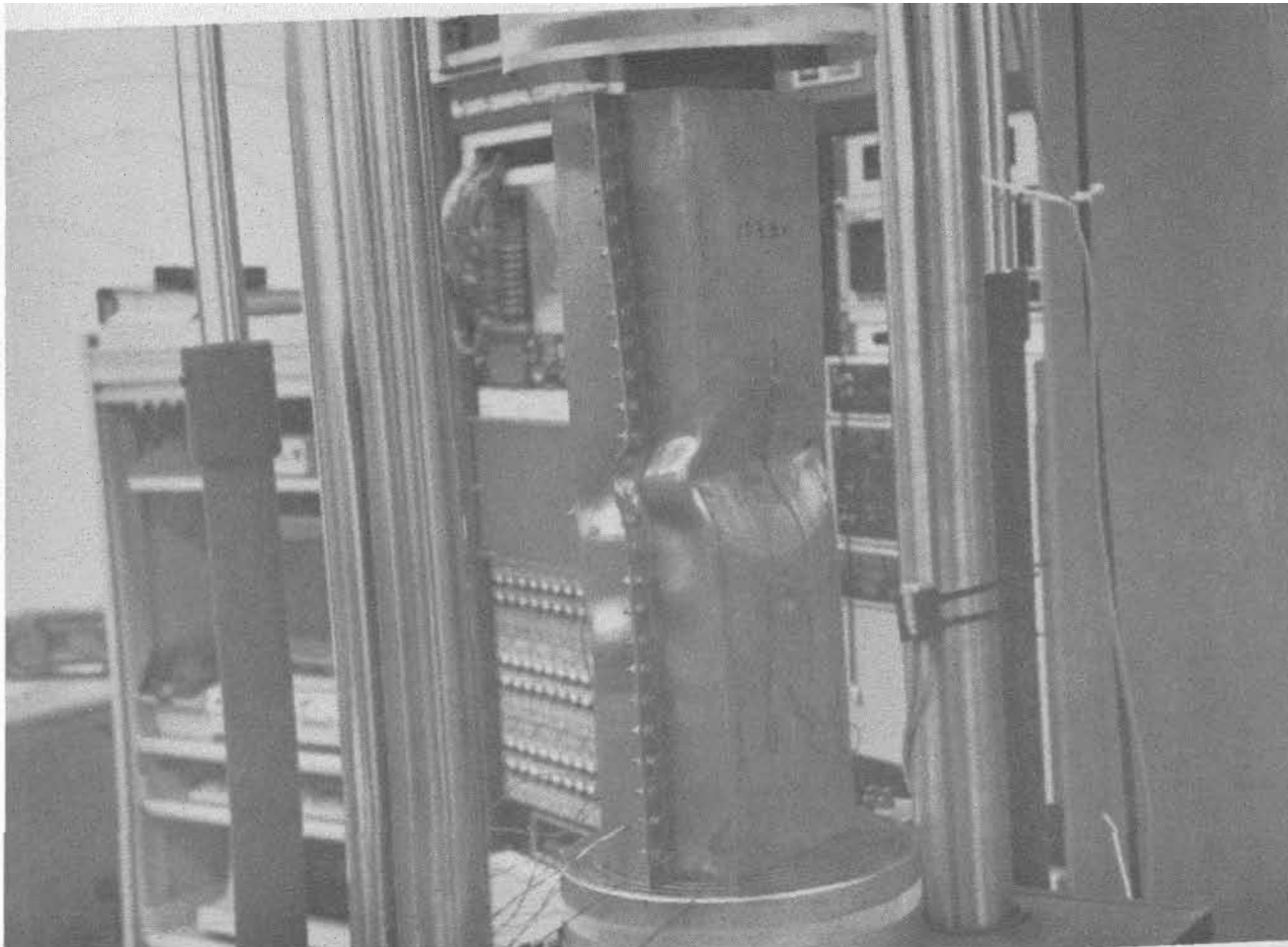

Figure 2.16 Typical Failure of Stub Columns with Large  $w/t$  ratios

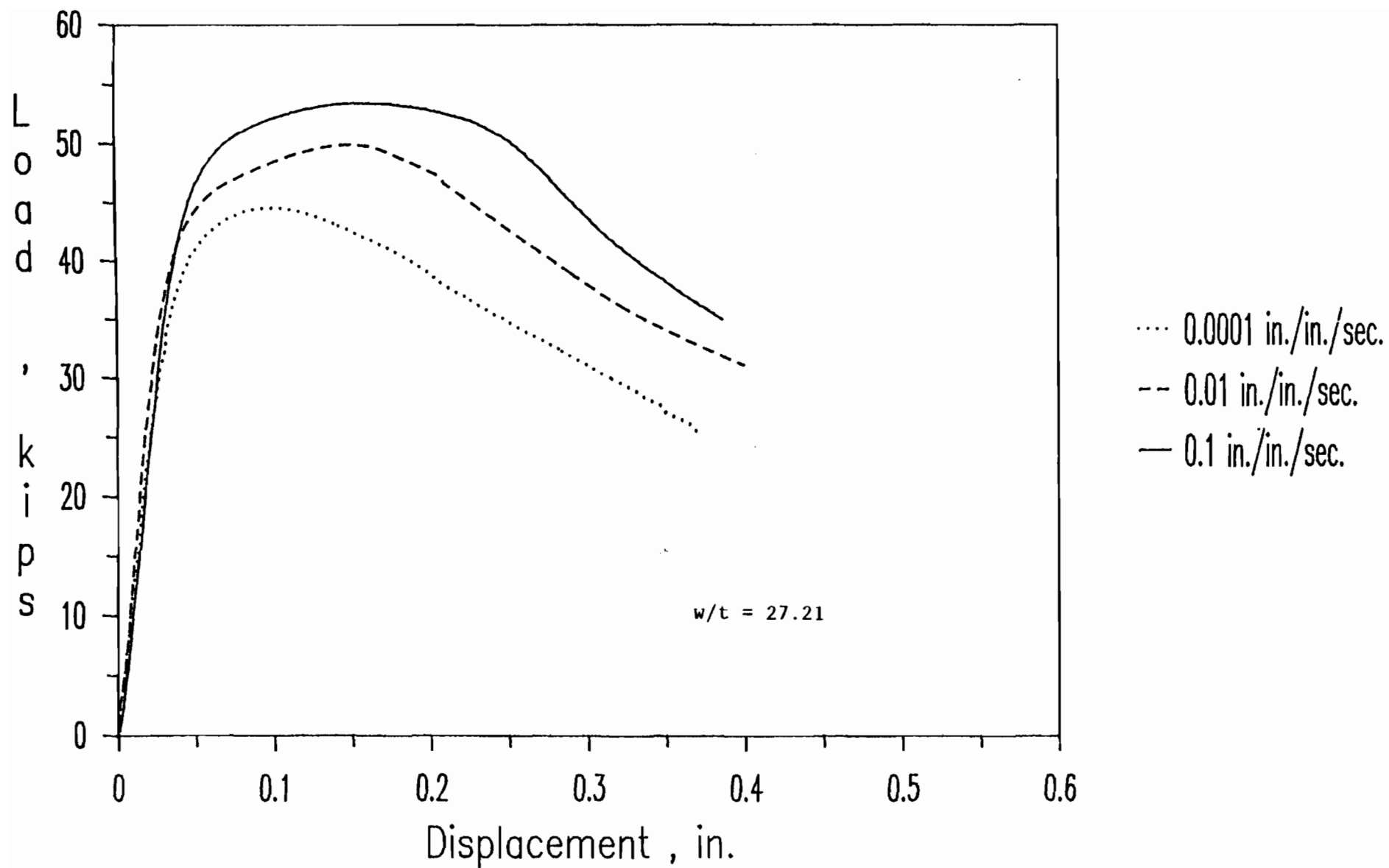

Figure 2.17 Load-Displacement Curves for Stub Column Specimens (35XF) 1A1A, 1A2A, and 1A3A

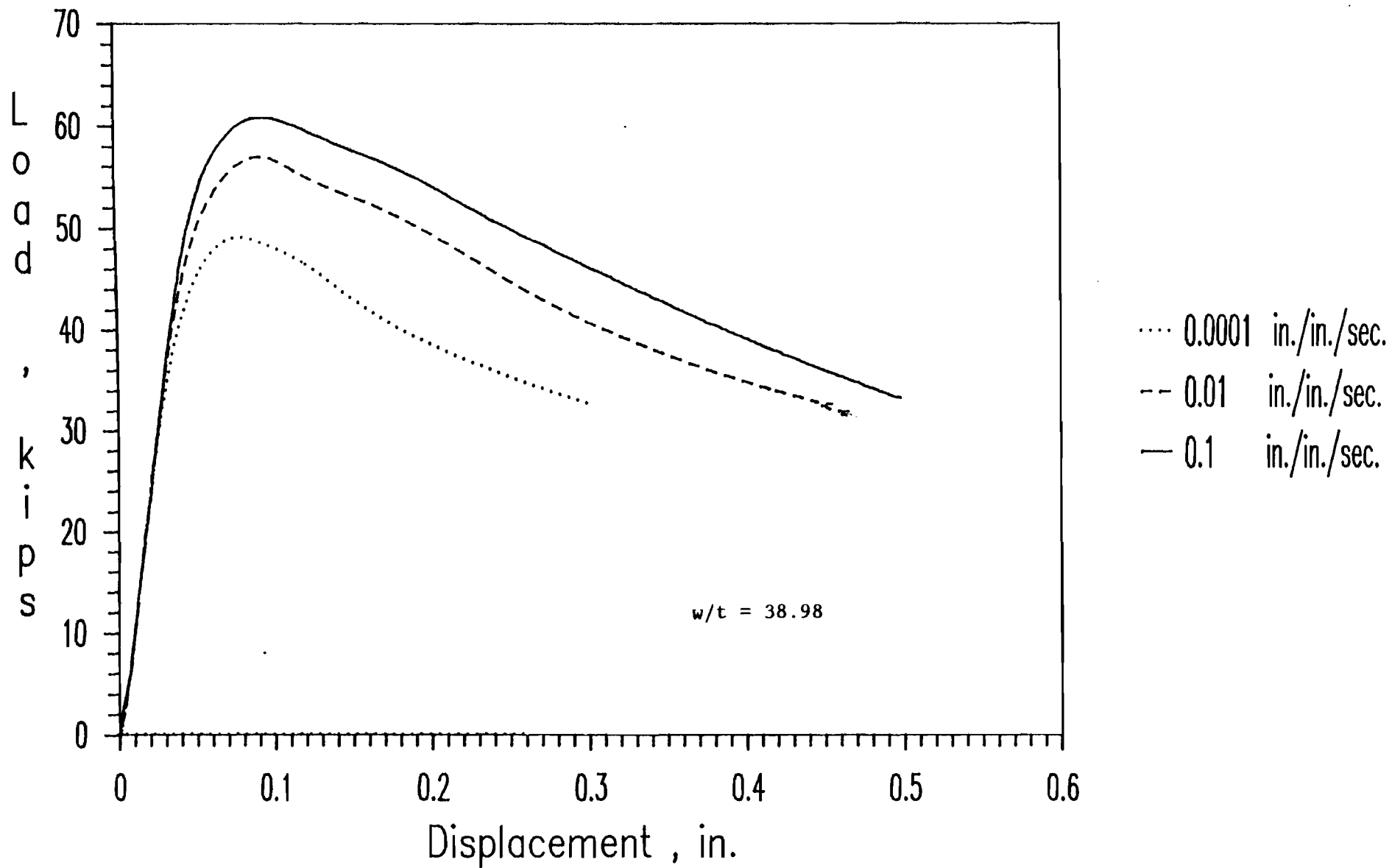

Figure 2.18 Load-Displacement Curves for Stub Column Specimens (35XF) 1B1A, 1B2A, and 1B3A

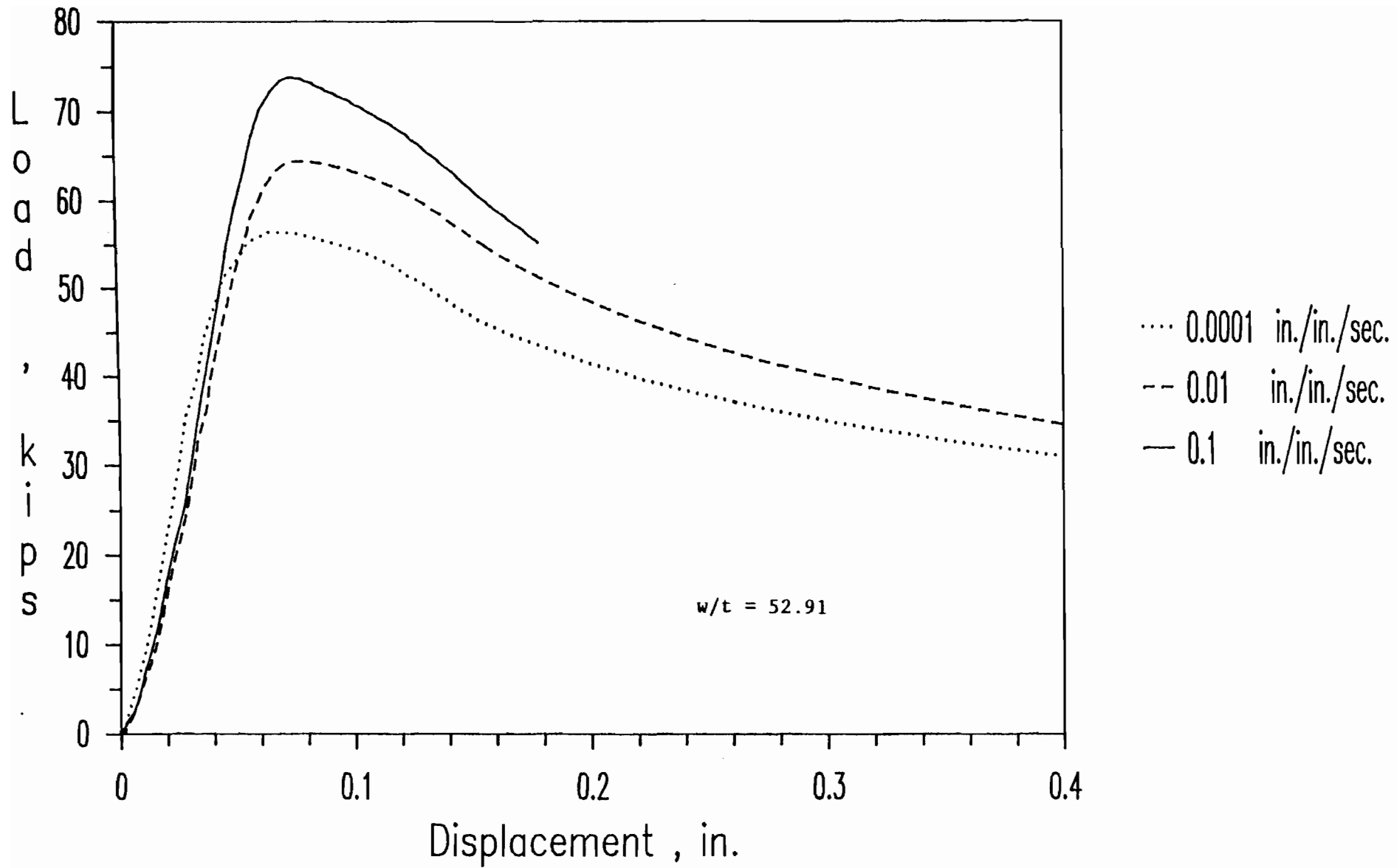

Figure 2.19 Load-Displacement Curves for Stub Column Specimens (35XF) 1C1A, 1C2A, and 1C3A

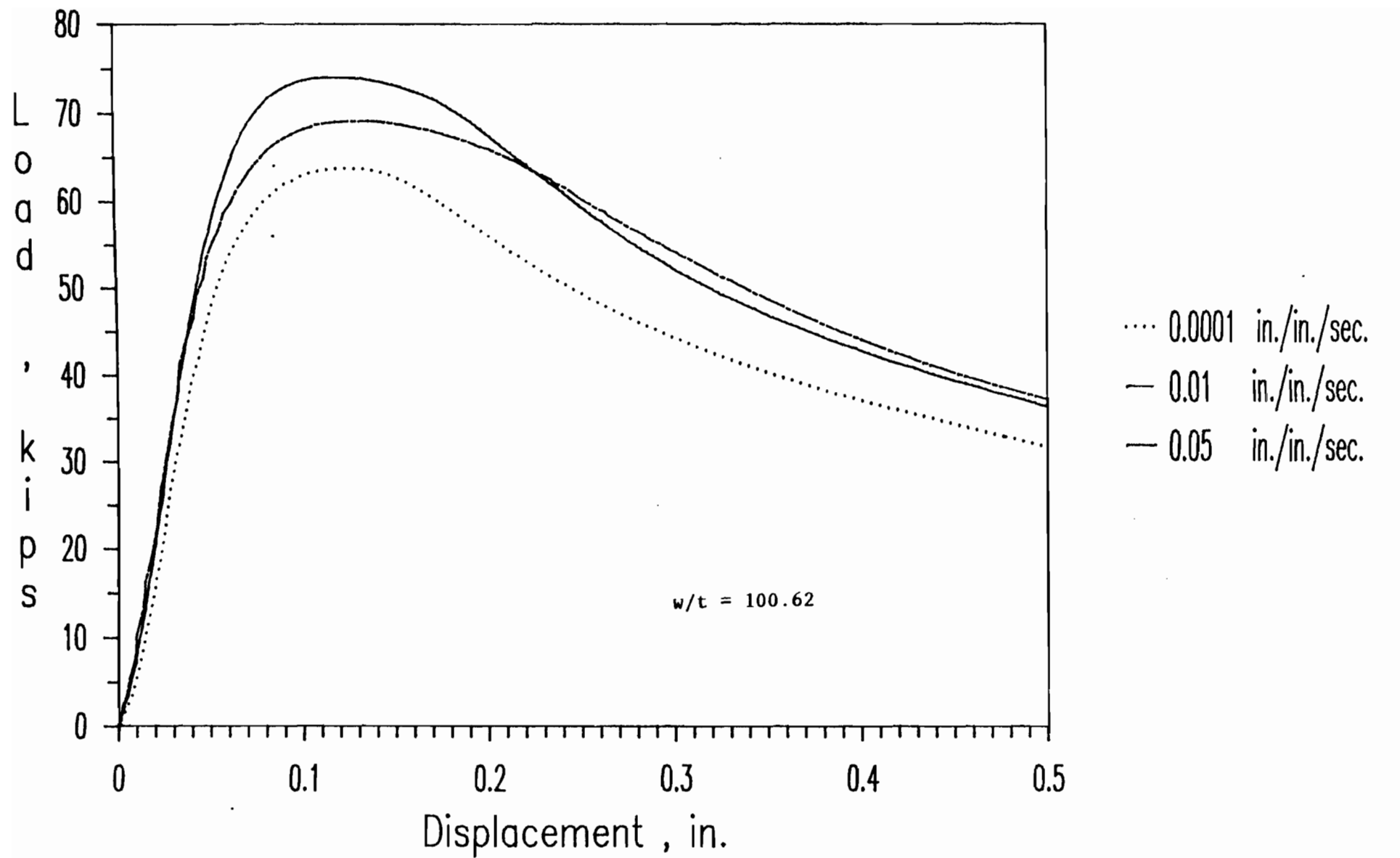

Figure 2.20 Load-Displacement Curves for Stub Column Specimens (35XF) 1D1A, 1D2A, and 1D3A

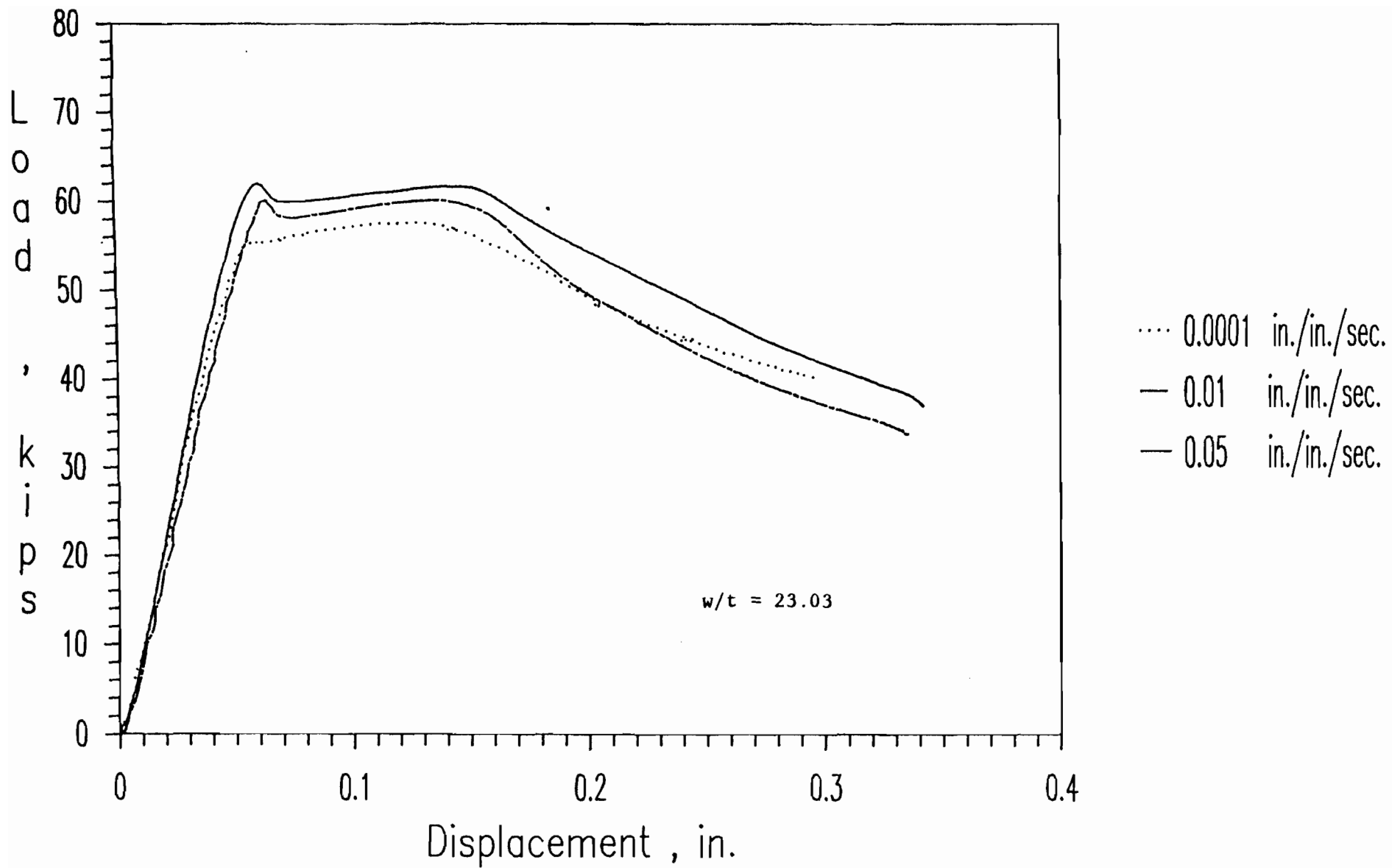

Figure 2.21 Load-Displacement Curves for Stub Column Specimens (50XF) 1A1BX, 1A2BX, and 1A3AX

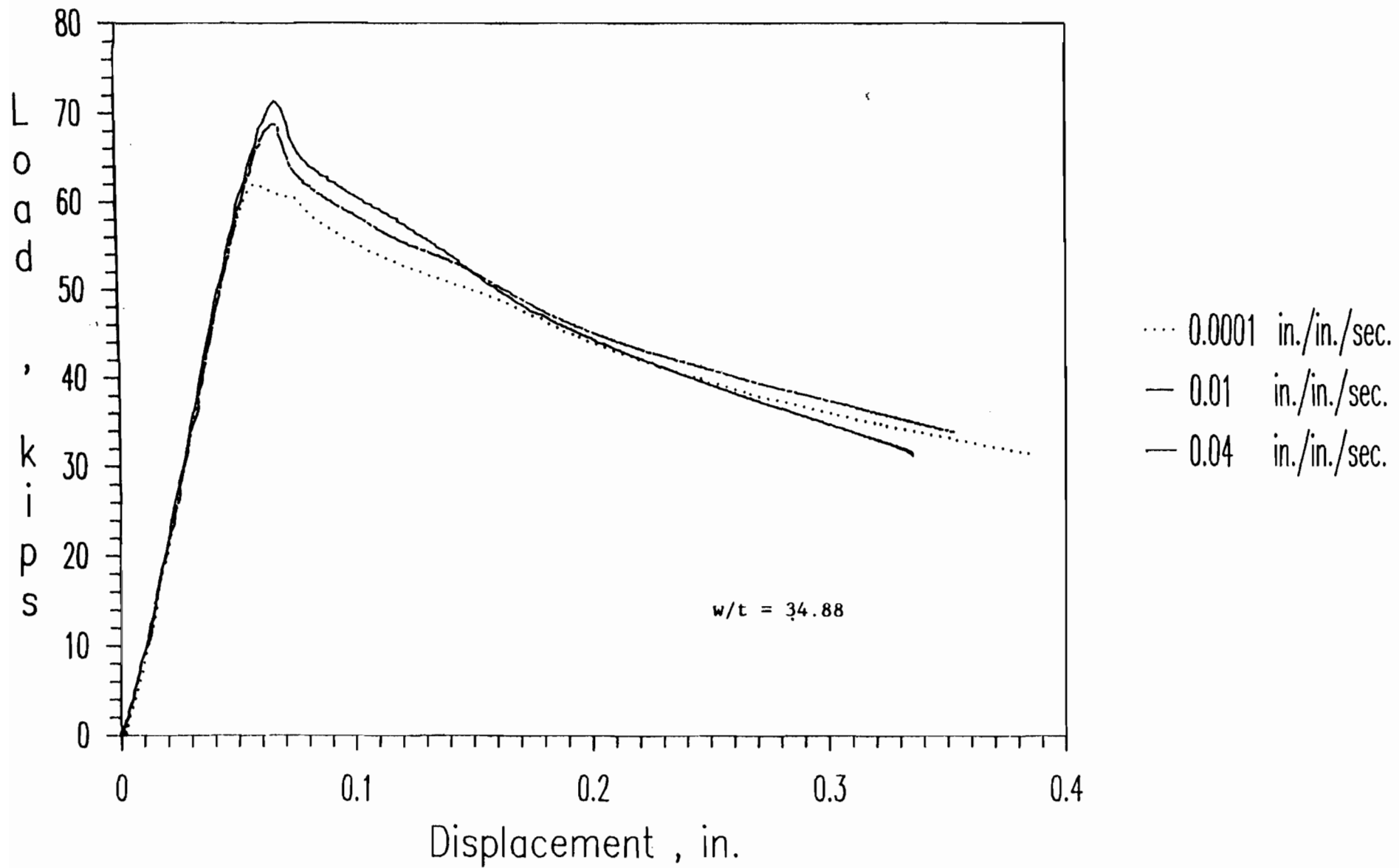

Figure 2.22 Load-Displacement Curves for Stub Column Specimens (50XF)  
1B1AX, 1B2AX, and 1B3AX

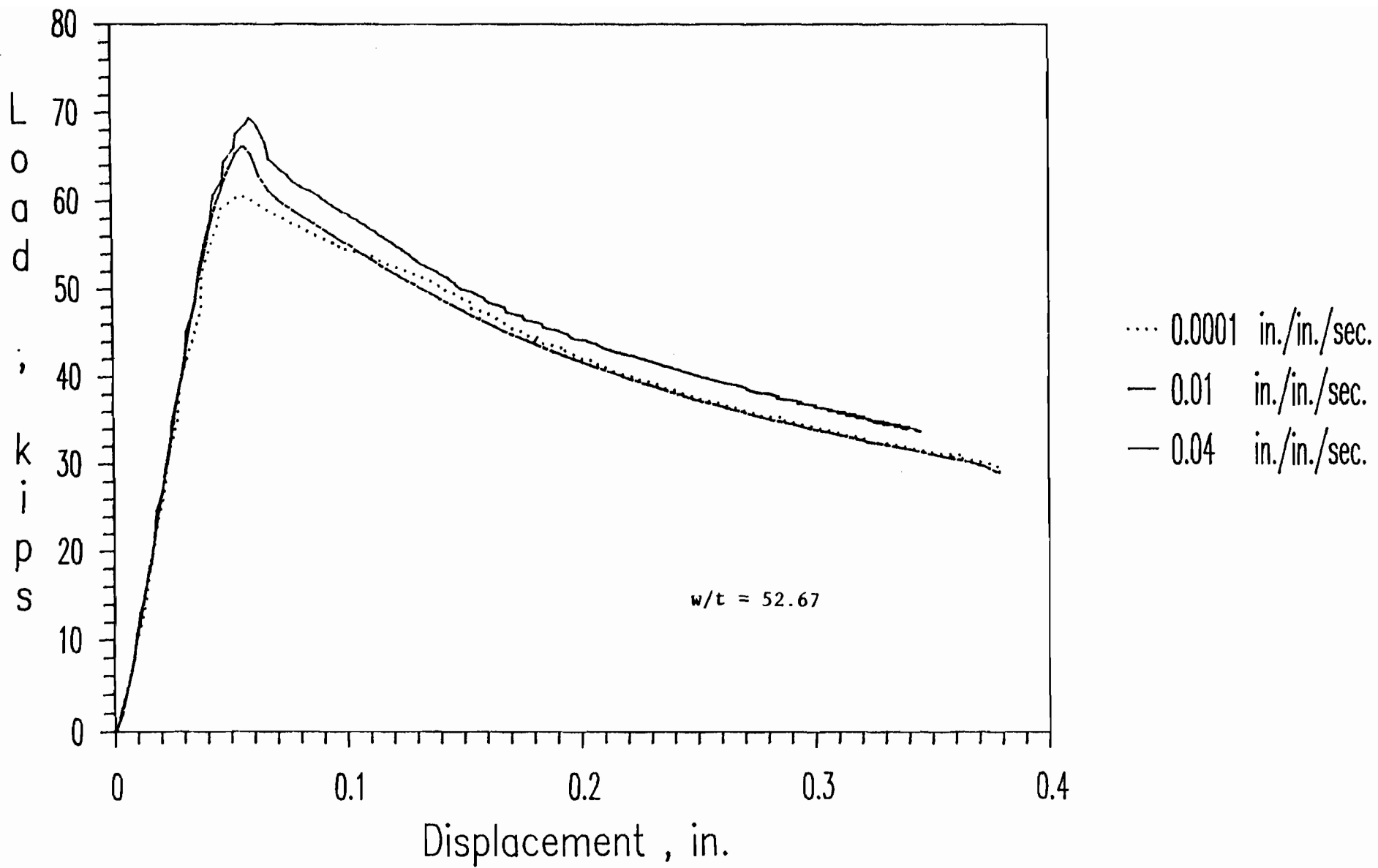

Figure 2.23 Load-Displacement Curves for Stub Column Specimens (50XF)  
1C1AX, 1C2BX, and 1C3BX



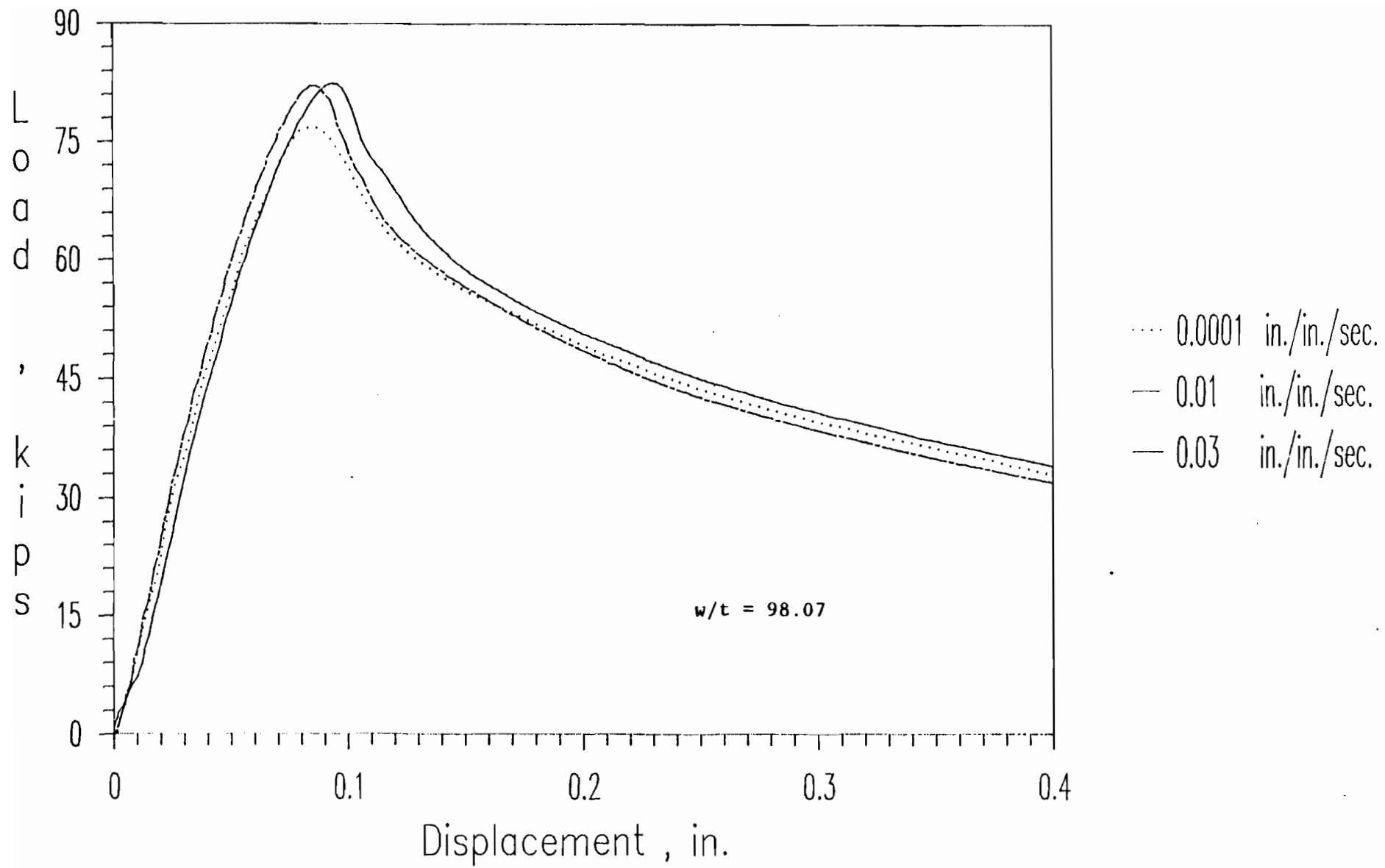

Figure 2.24 Load-Displacement Curves for Stub Column Specimens (50XF)  
1D1AX, 1D2AX, and 1D3AX

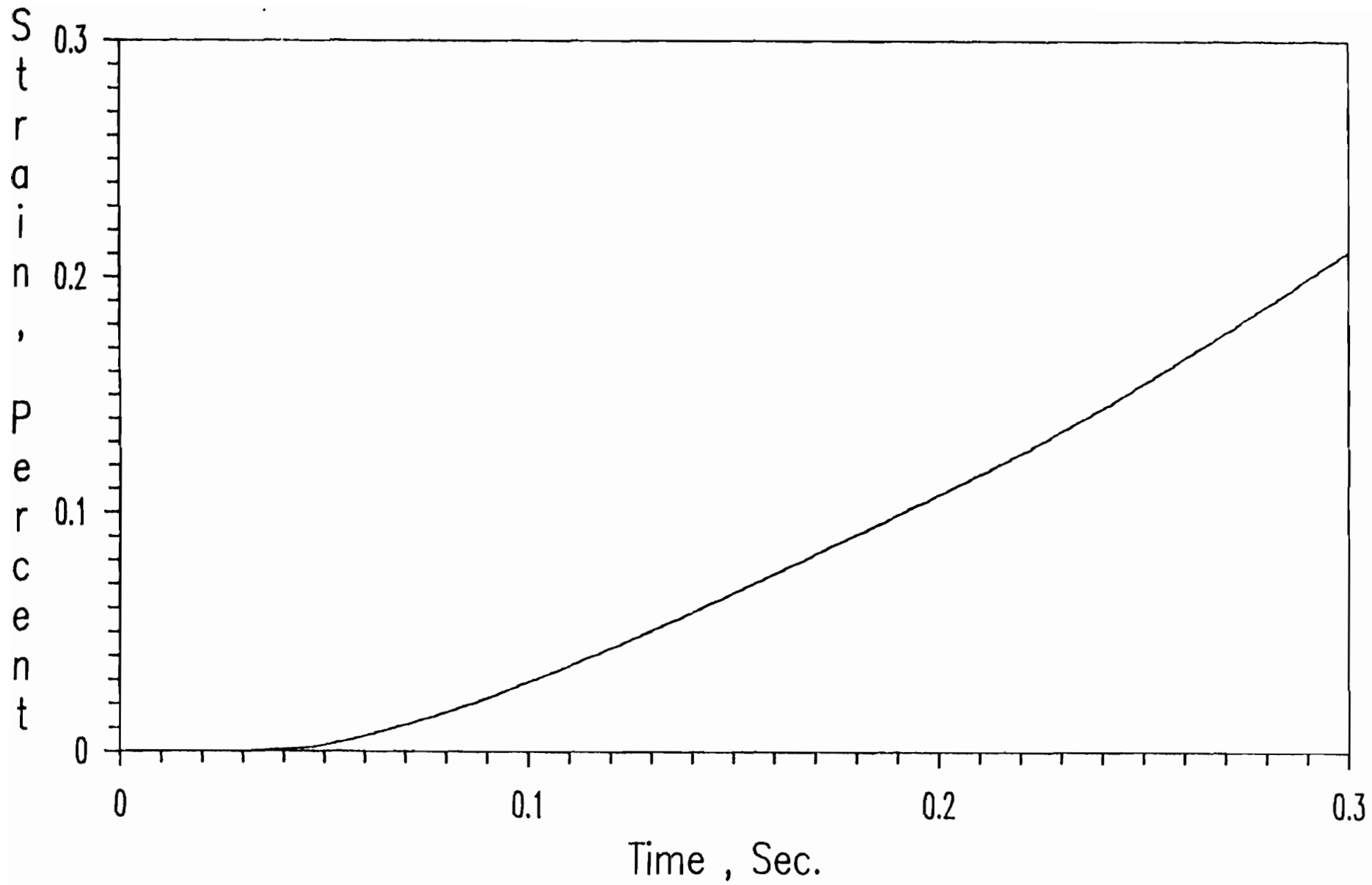

Figure 2.25 Typical Plot of Strain-Time Relationship for Stub Columns with Stiffened Elements Under Intermediate Strain Rate (Spec. 1B2BX)

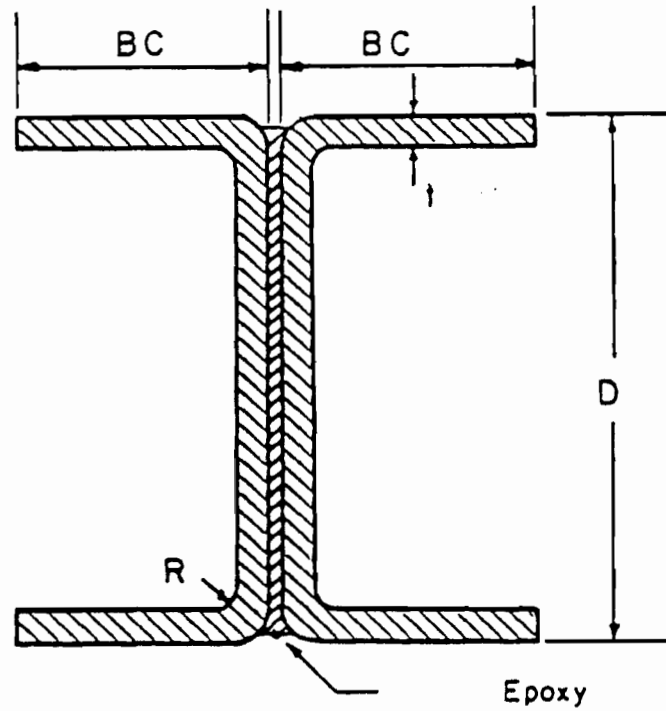

Figure 2.26 Cross Section of I-shaped Stub Columns Used for the Study of Unstiffened Elements

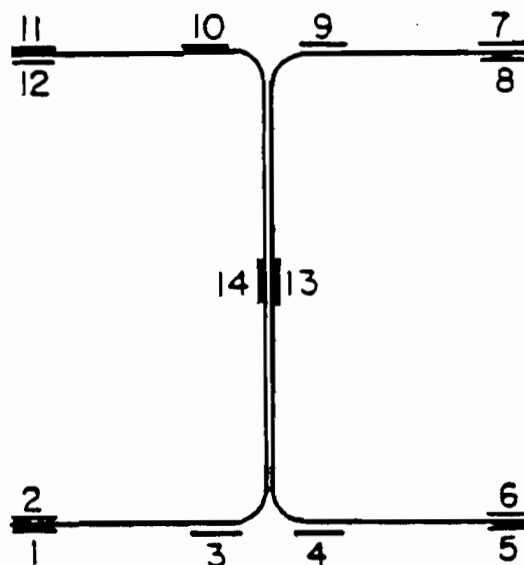

Figure 2.27 Locations of Strain Gages at Midheight of I-Shaped Stub Columns

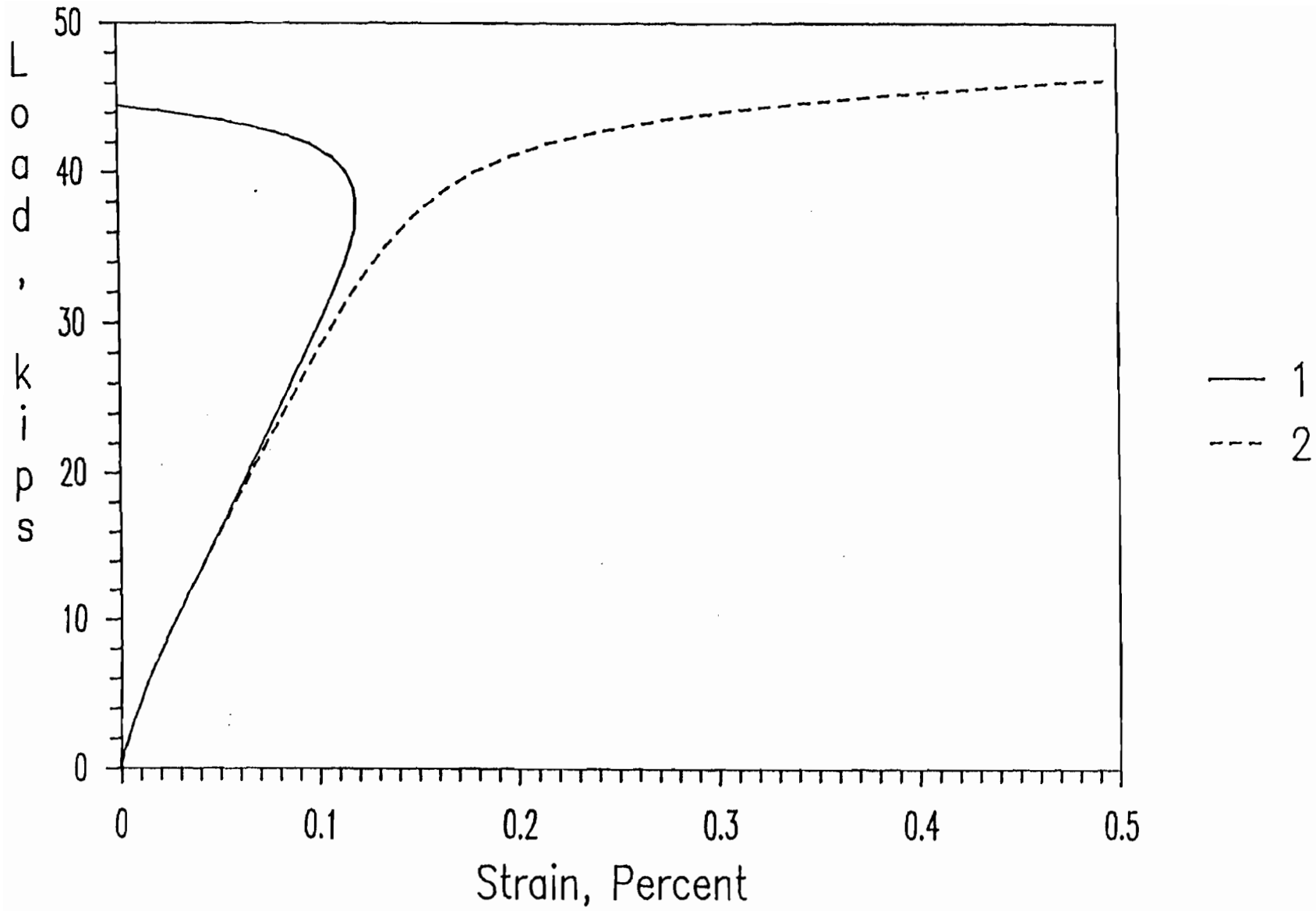

Figure 2.28 Load-Strain Curves of Strain Gages # 1 and 2 Installed at the Tips of Unstiffened Elements (Spec. 2C2BX)

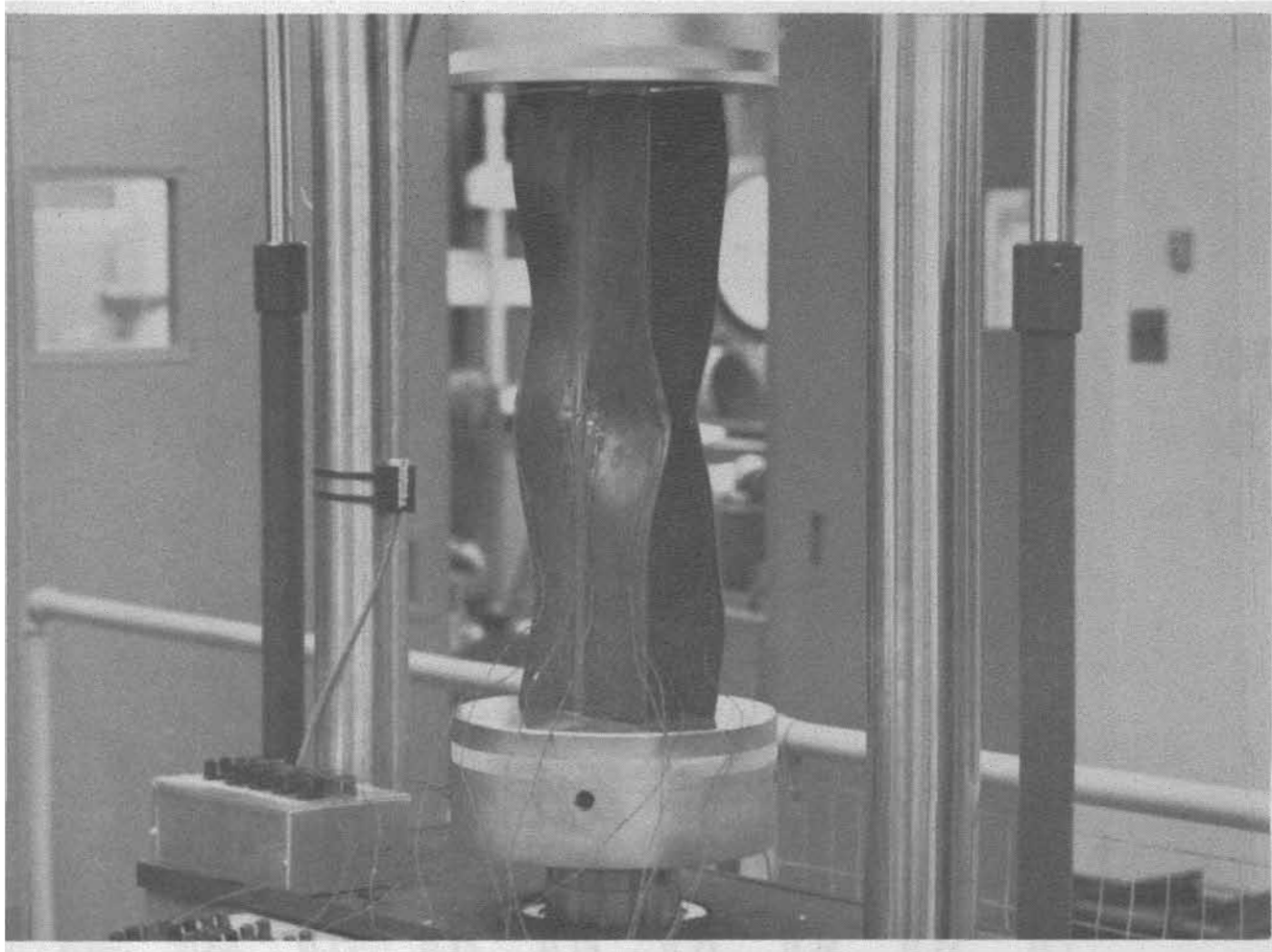

Figure 2.29 Typical Failure of Stub Columns with Large  $w/t$  Ratios

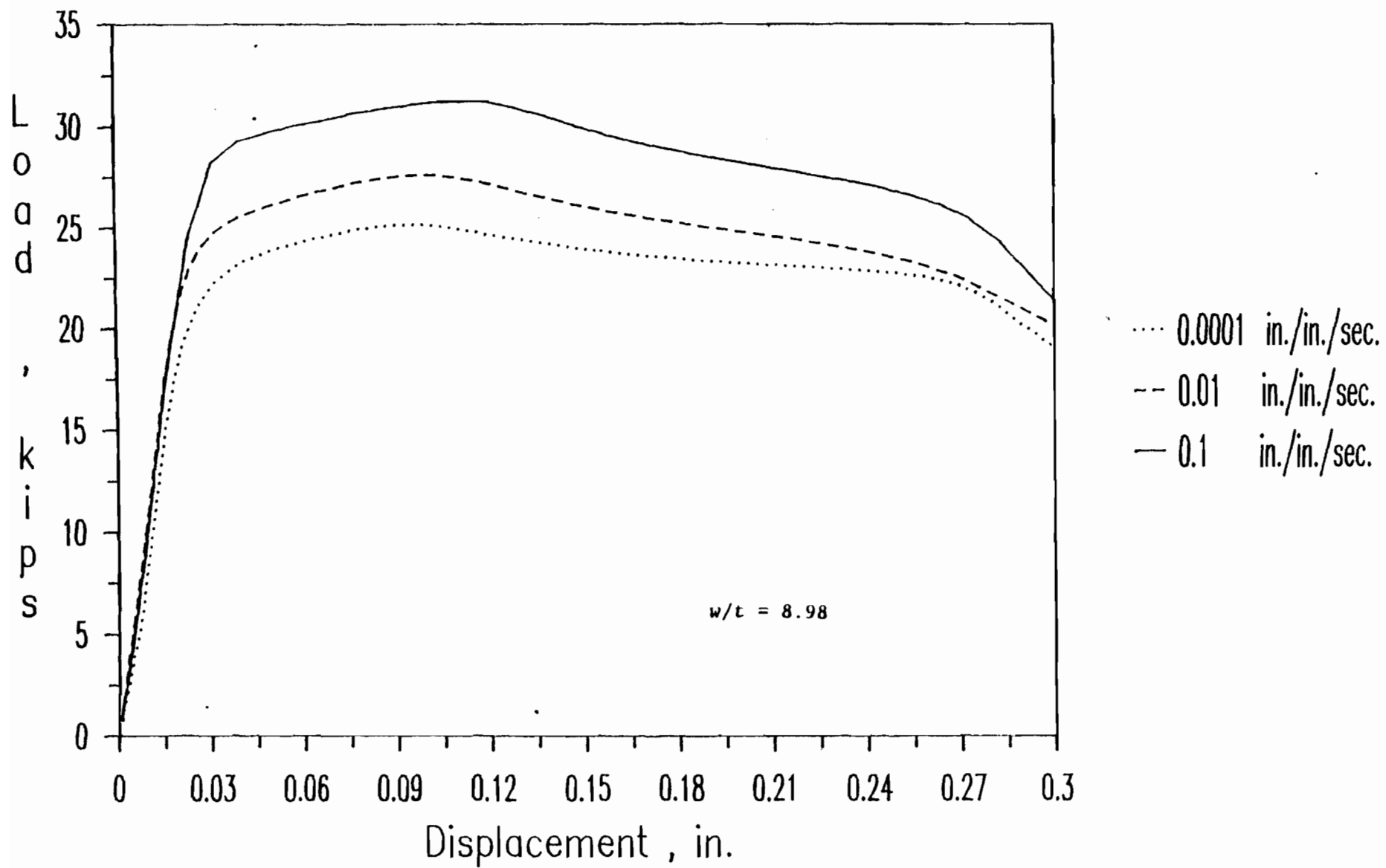

Figure 2.30 Load-Displacement Curves for Stub Column Specimens (35XF) 2A1A, 2A2A, and 2A3A

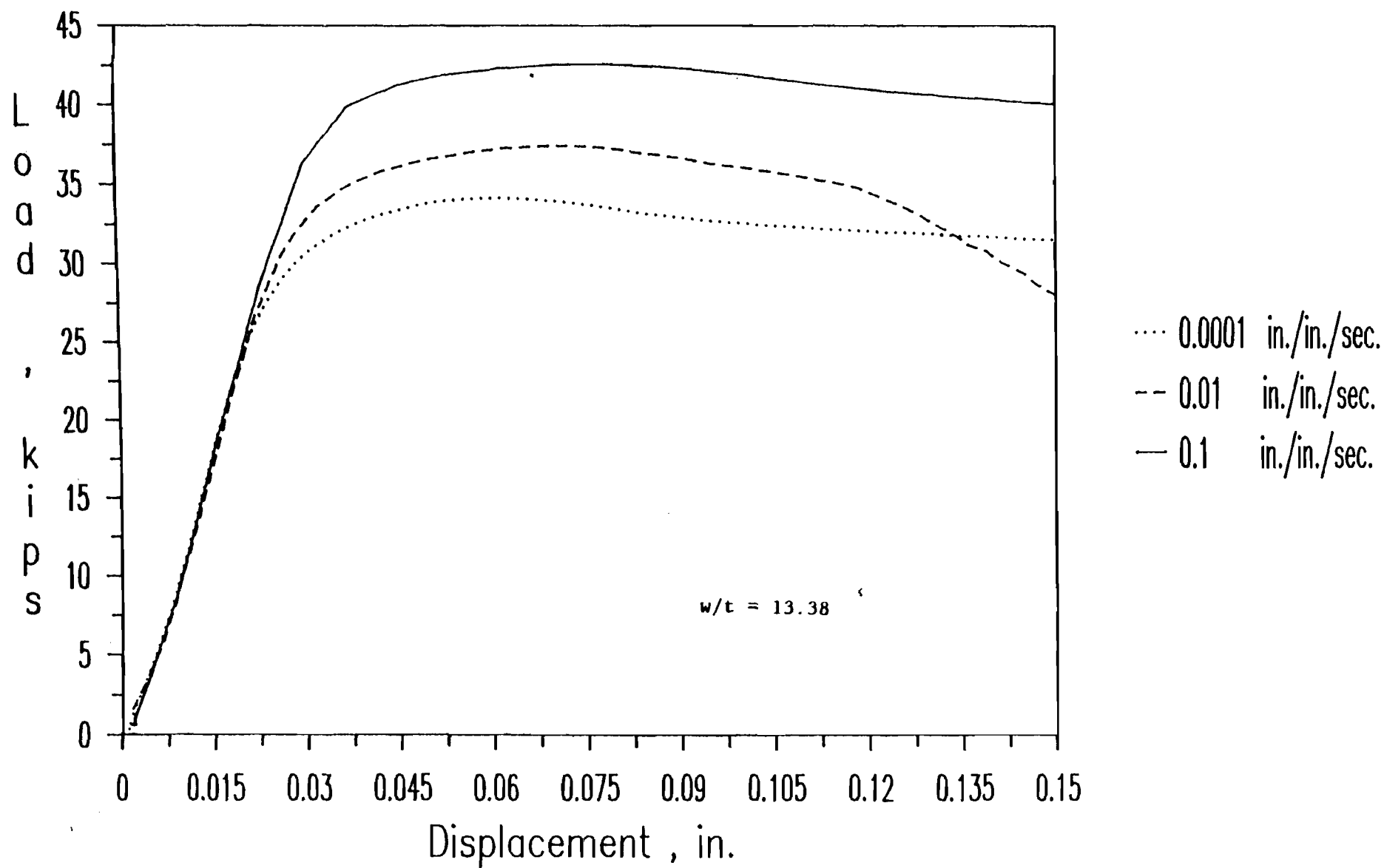

Figure 2.31 Load-Displacement Curves for Stub Column Specimens (35XF) 2B1A, 2B2A, and 2B3A

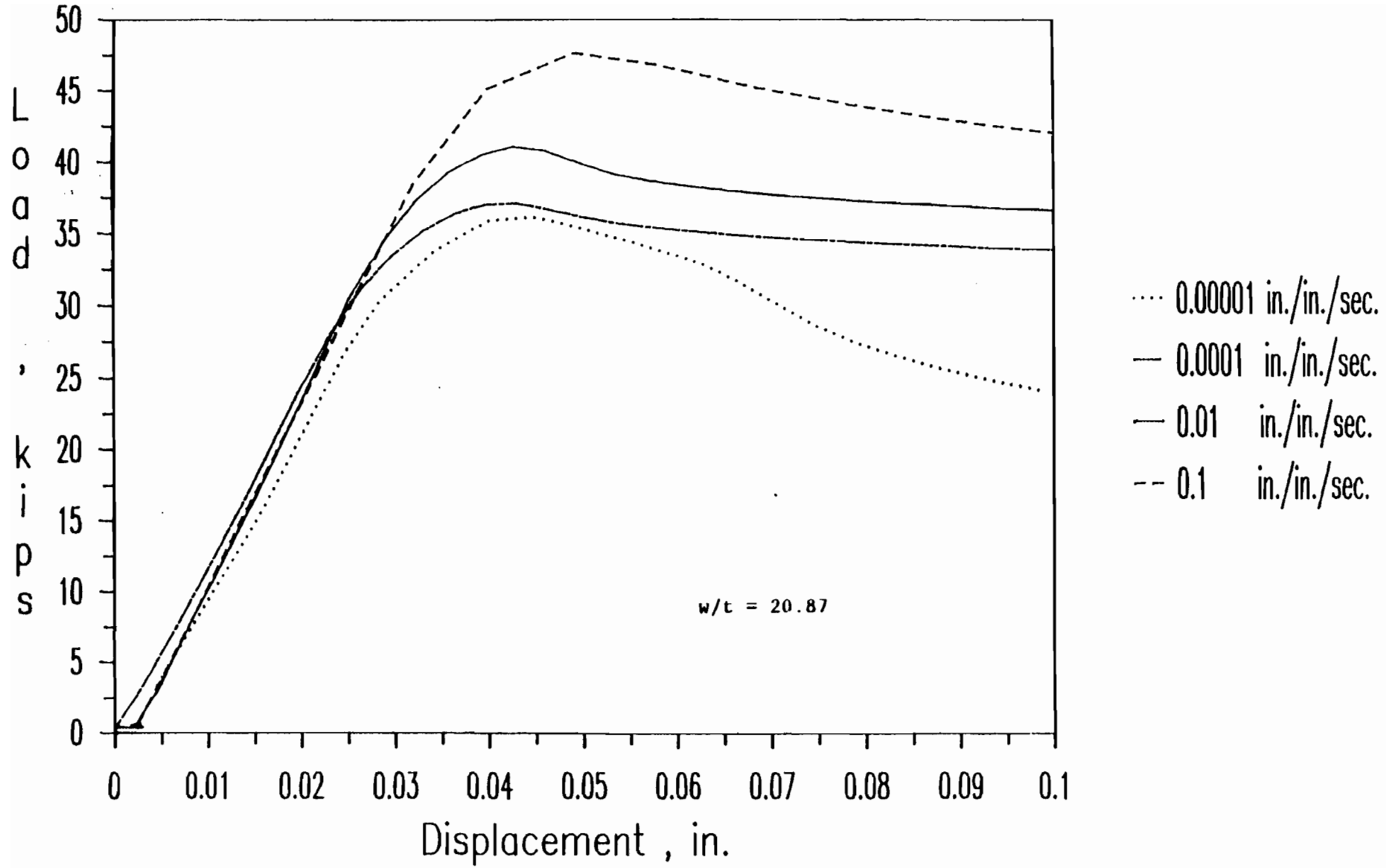

Figure 2.32 Load-Displacement Curves for Stub Column Specimens (35XF) 2C1A, 2C2A, and 2C3A



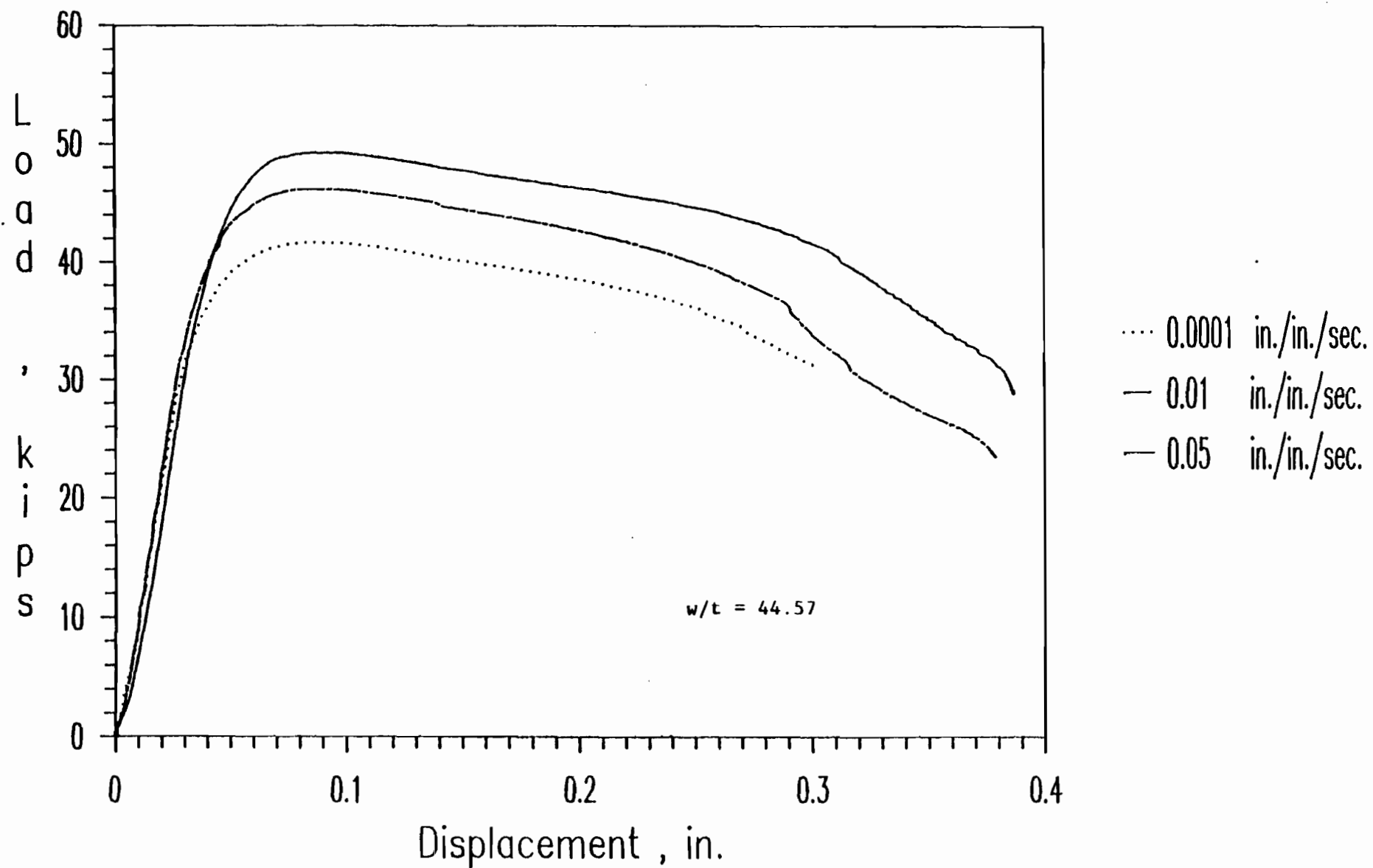

Figure 2.33 Load-Displacement Curves for Stub Column Specimens (35XF)  
2D1A, 2D2A, and 2D3A

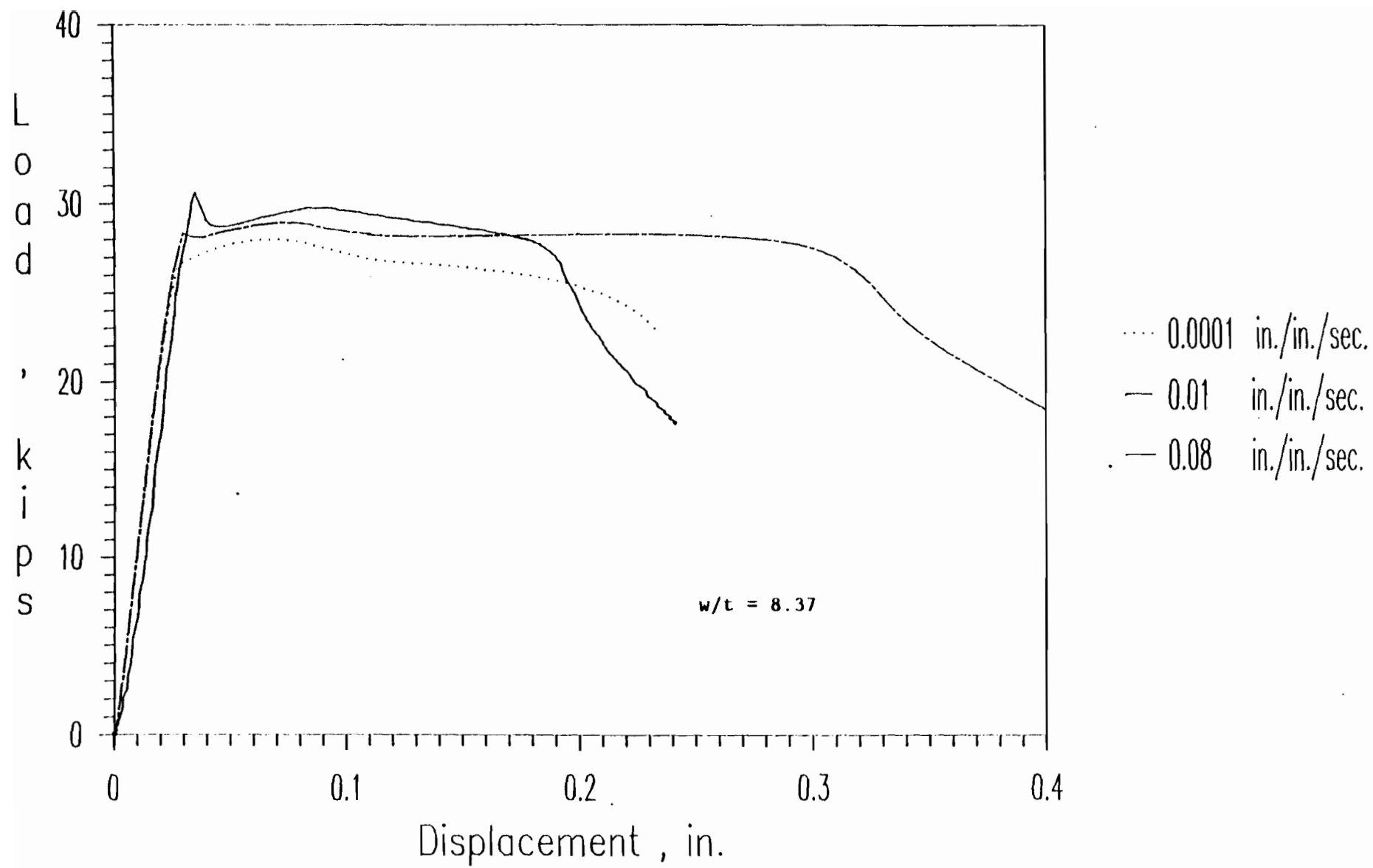

Figure 2.34 Load-Displacement Curves for Stub Column Specimens (50XF)  
2A1AX, 2A2AX, and 2A3AX

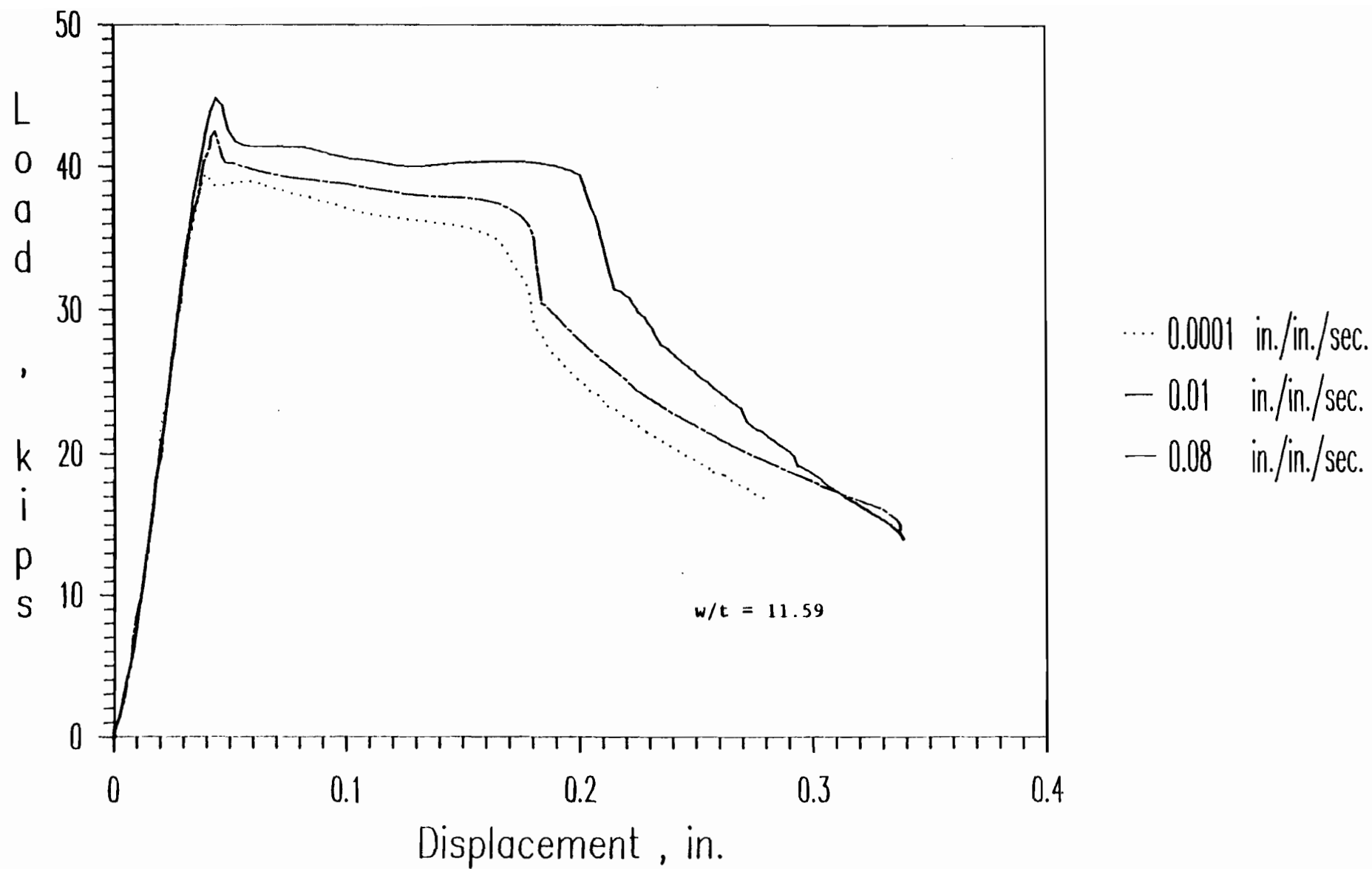

Figure 2.35 Load-Displacement Curves for Stub Column Specimens (50XF)  
 2B1AX, 2B2AX, and 2B3AX

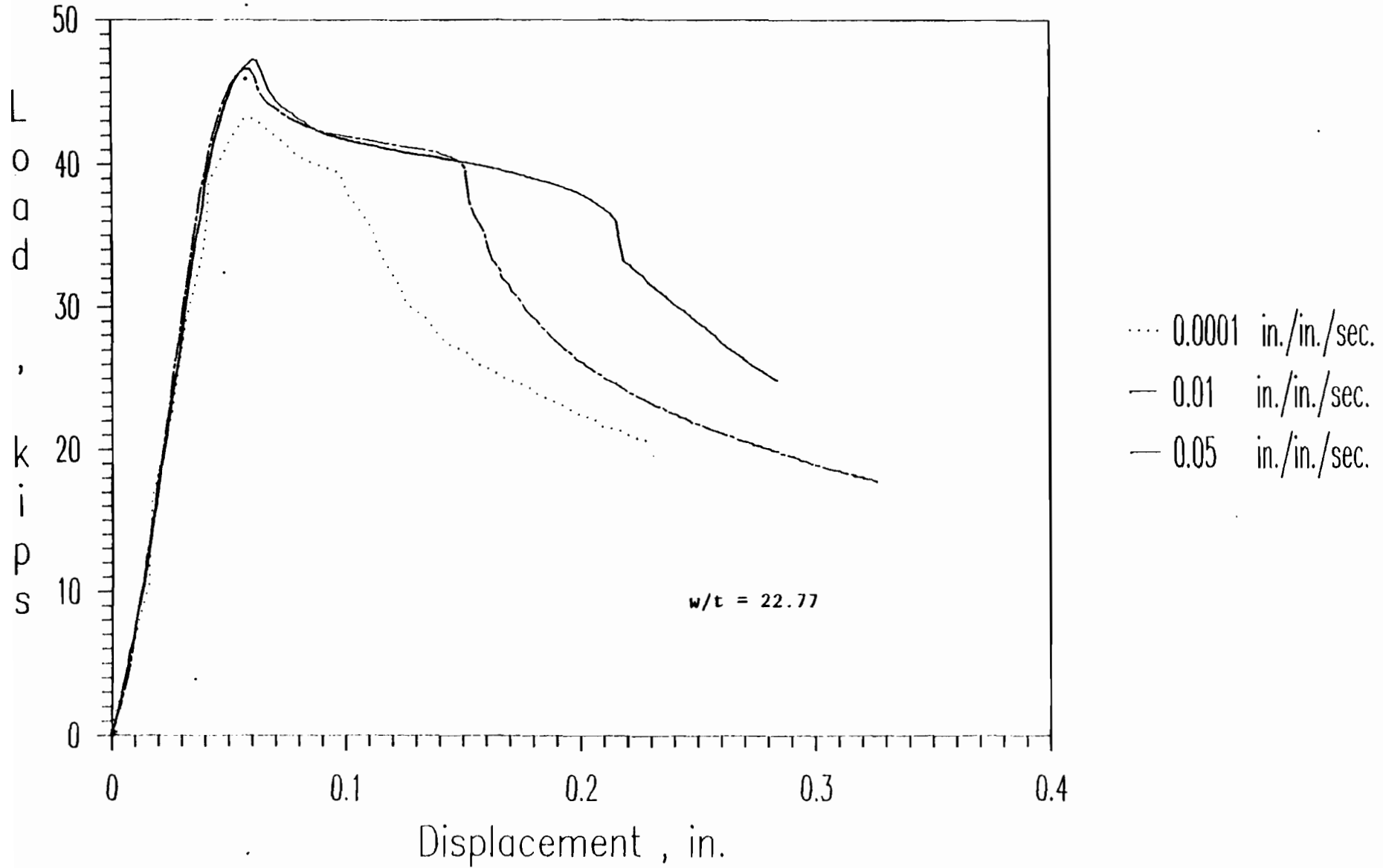

Figure 2.36 Load-Displacement Curves for Stub Column Specimens (50XF)  
2C1AX, 2C2AX, and 2C3AX

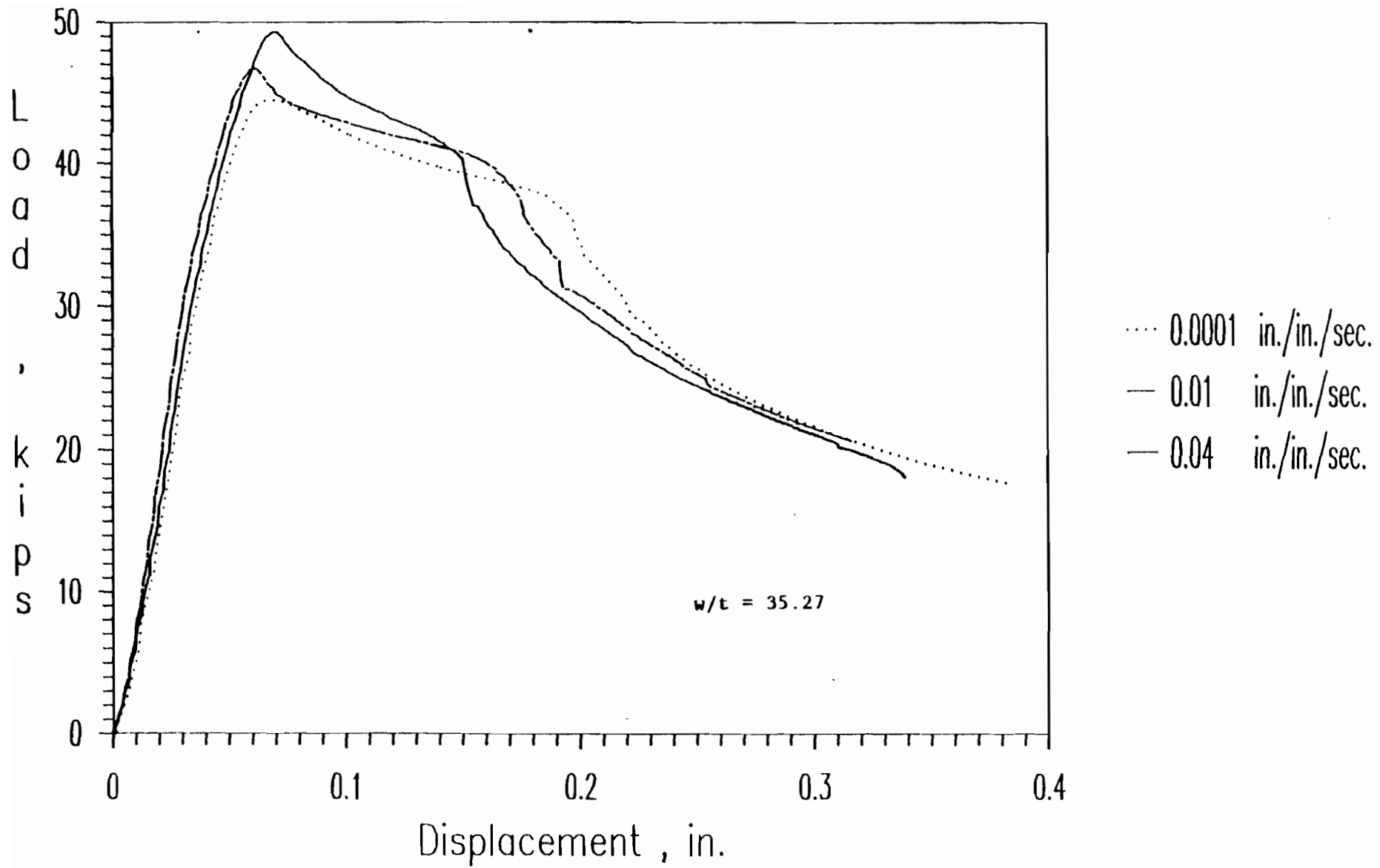

Figure 2.37 Load-Displacement Curves for Stub Column Specimens (50XF)  
2D1AX, 2D2AX, and 2D3AX

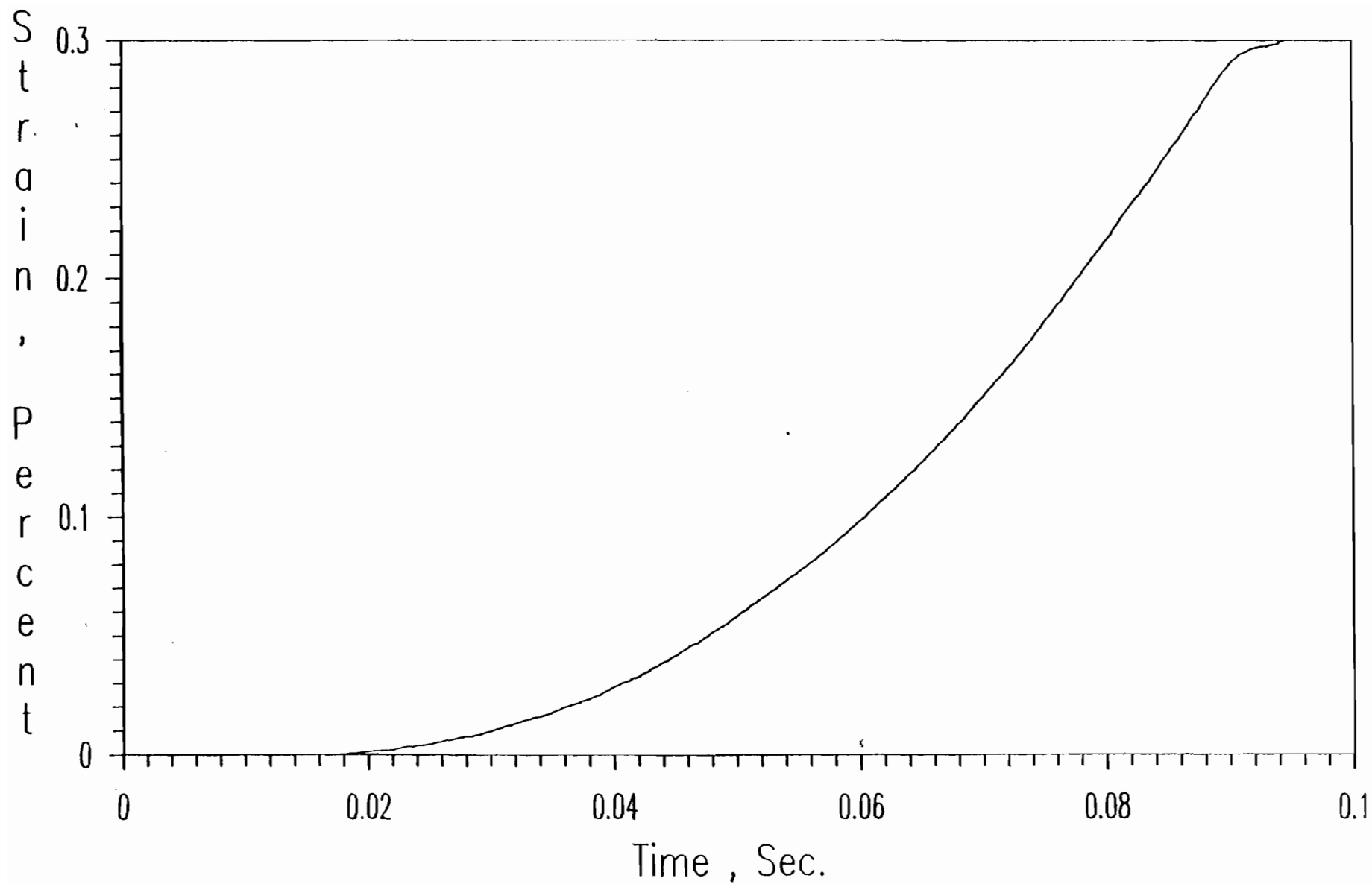

Figure 2.38 Typical Plot of Strain-Time Relationship for Stub Columns with Stiffened Elements (Spec. 2A3AX)

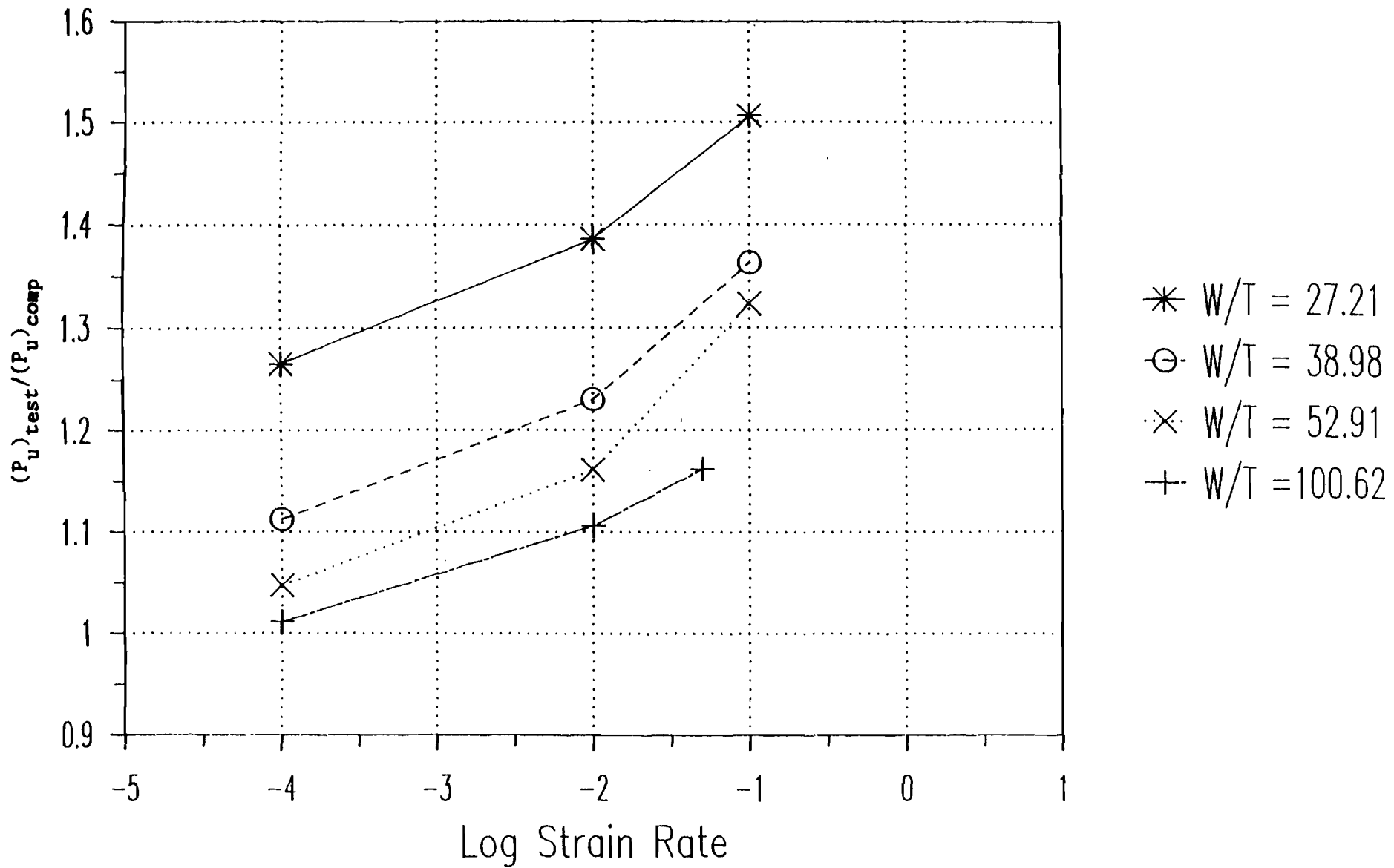

Figure 3.1 Ratios of Tested Ultimate Loads to Computed Ultimate Loads (Based on Static Yield Stress) vs. Logarithmic Strain Rate for Box-Shaped Stub Columns (35XF Sheet Steel)

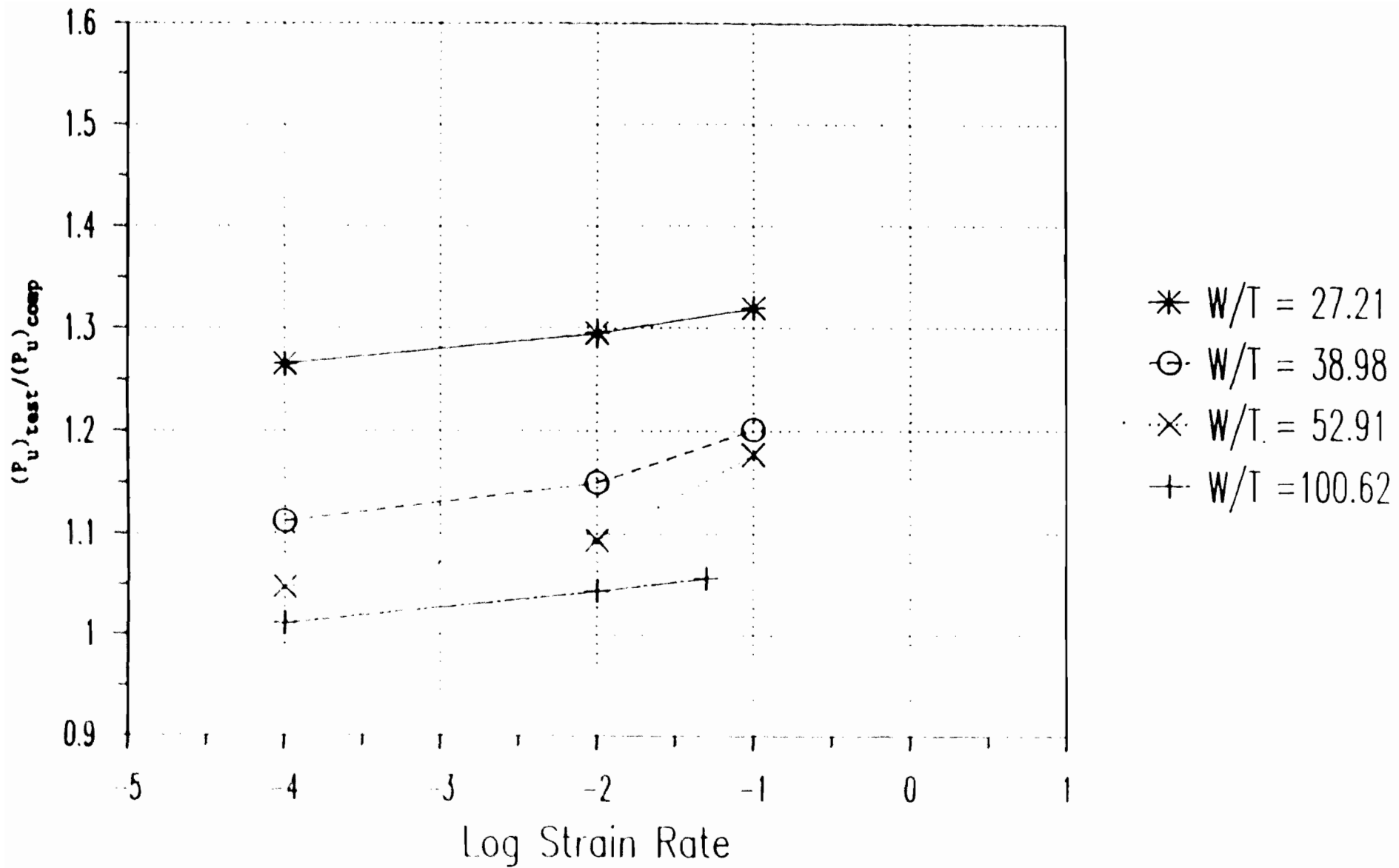

Figure 3.2 Ratios of Tested Ultimate Loads to Computed Ultimate Loads (Based on Dynamic Yield Stresses) vs. Logarithmic Strain Rate for Box-Shaped Stub Columns (35XF Sheet Steel)



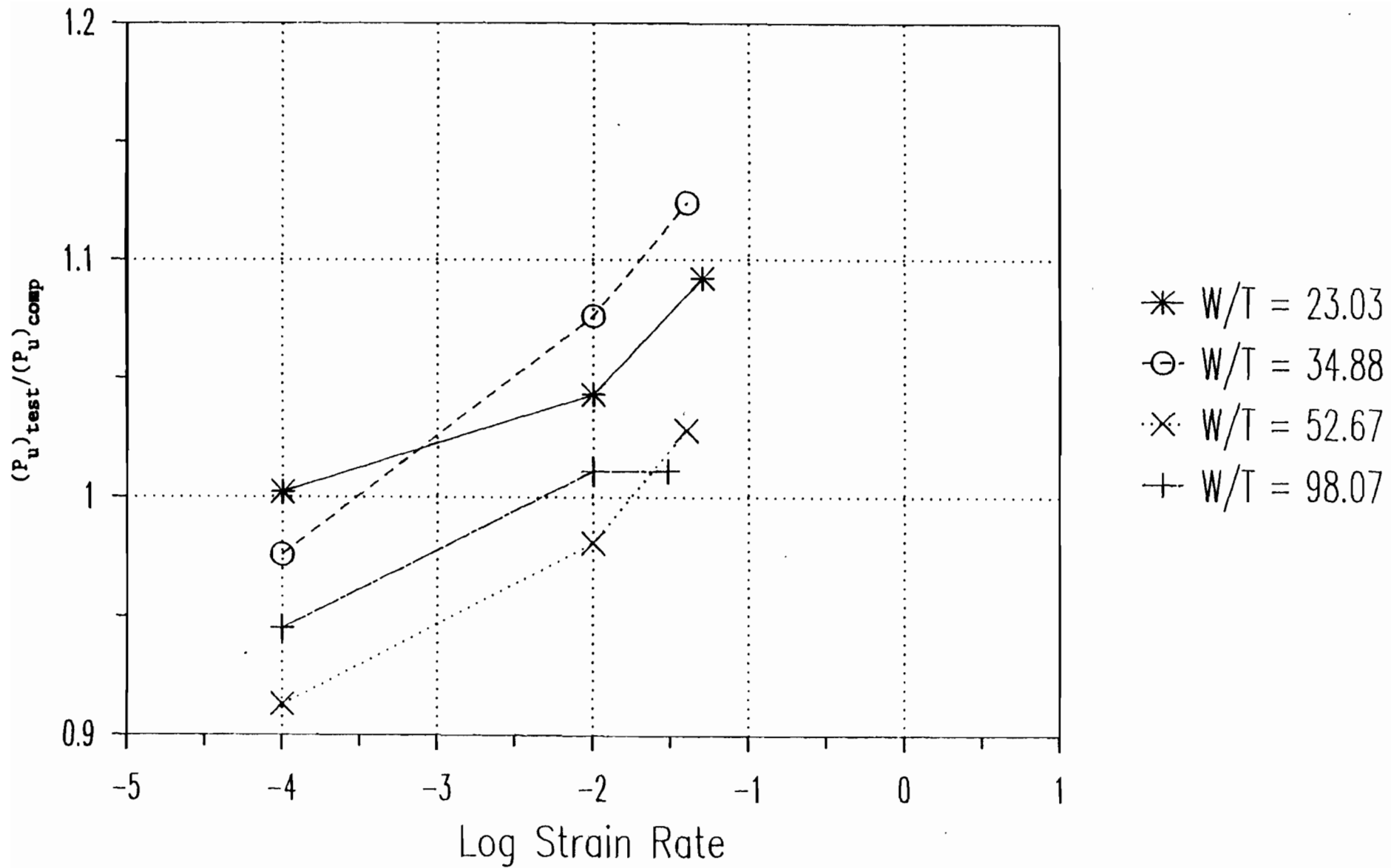

Figure 3.3 Ratios of Tested Ultimate Loads to Computed Ultimate Loads (Based on Static Yield Stress) vs. Logarithmic Strain Rate for Box-Shaped Stub Columns (50XF Sheet Steel)

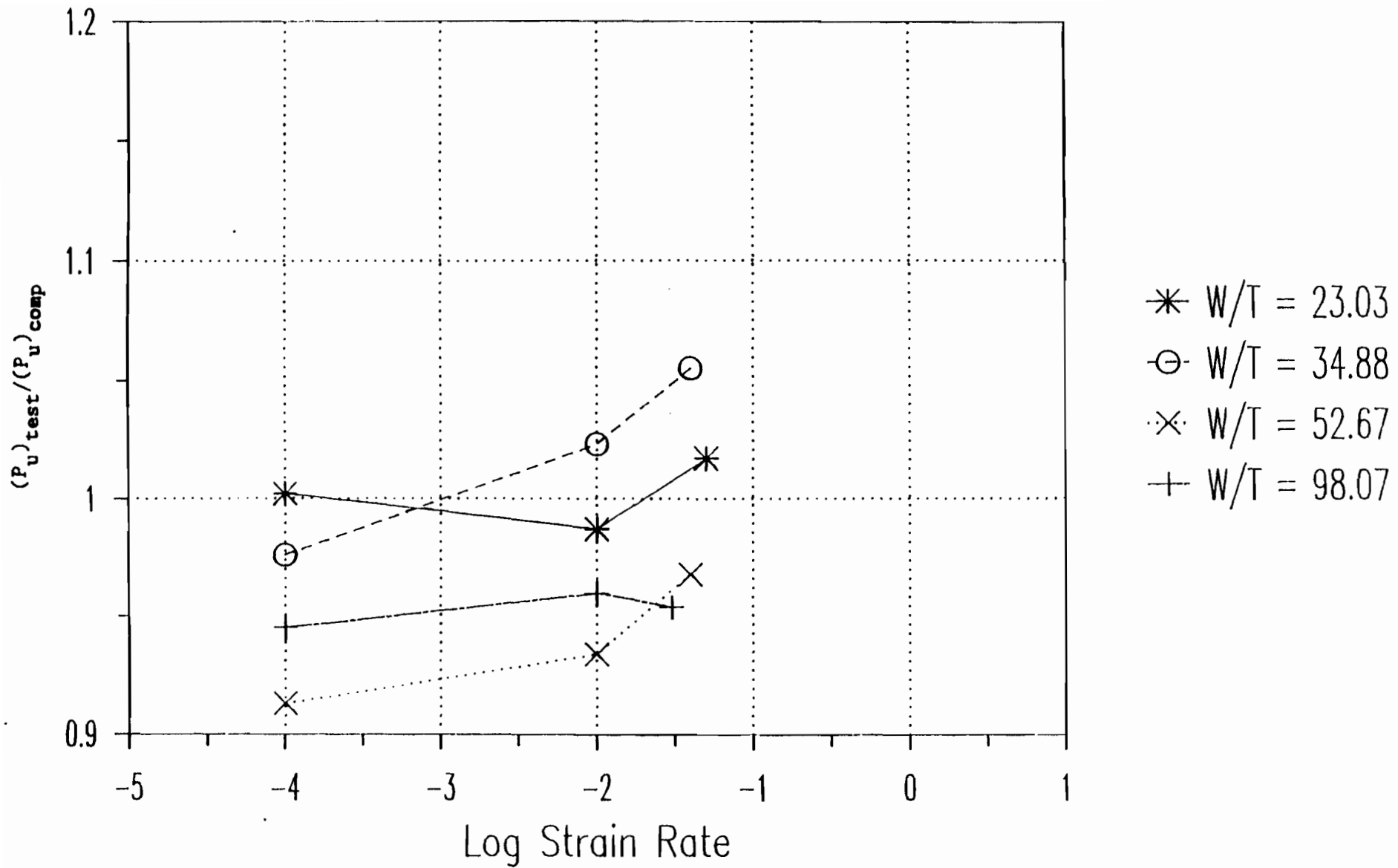

Figure 3.4 Ratios of Tested Ultimate Loads to Computed Ultimate Loads (Based on Dynamic Yield Stresses) vs. Logarithmic Strain Rate for Box-Shaped Stub Columns (50XF Sheet Steel)

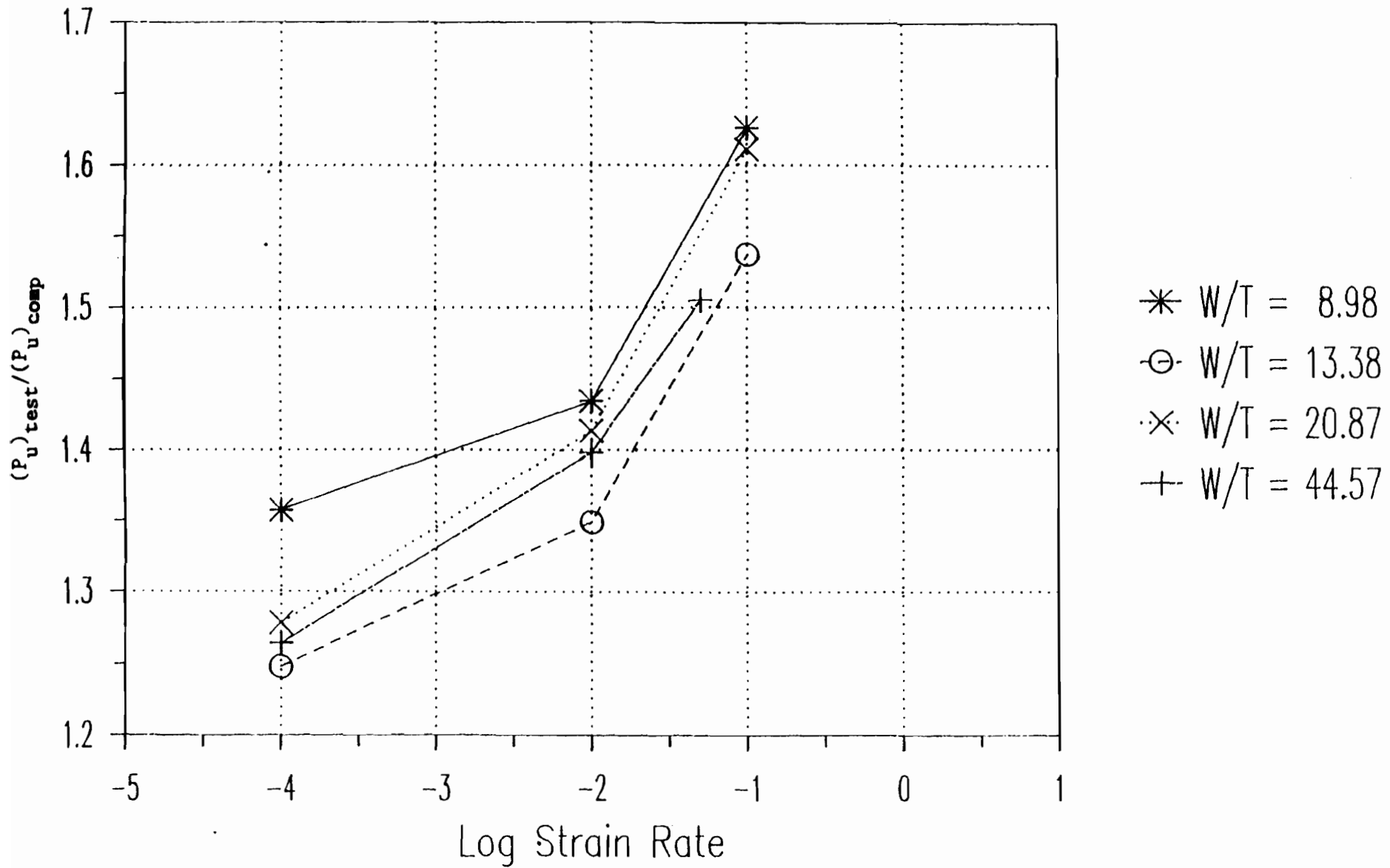

Figure 3.5 Ratios of Tested Ultimate Loads to Computed Ultimate Loads (Based on Static Yield Stress) vs. Logarithmic Strain Rate for I-Shaped Stub Columns (35XF Sheet Steel)

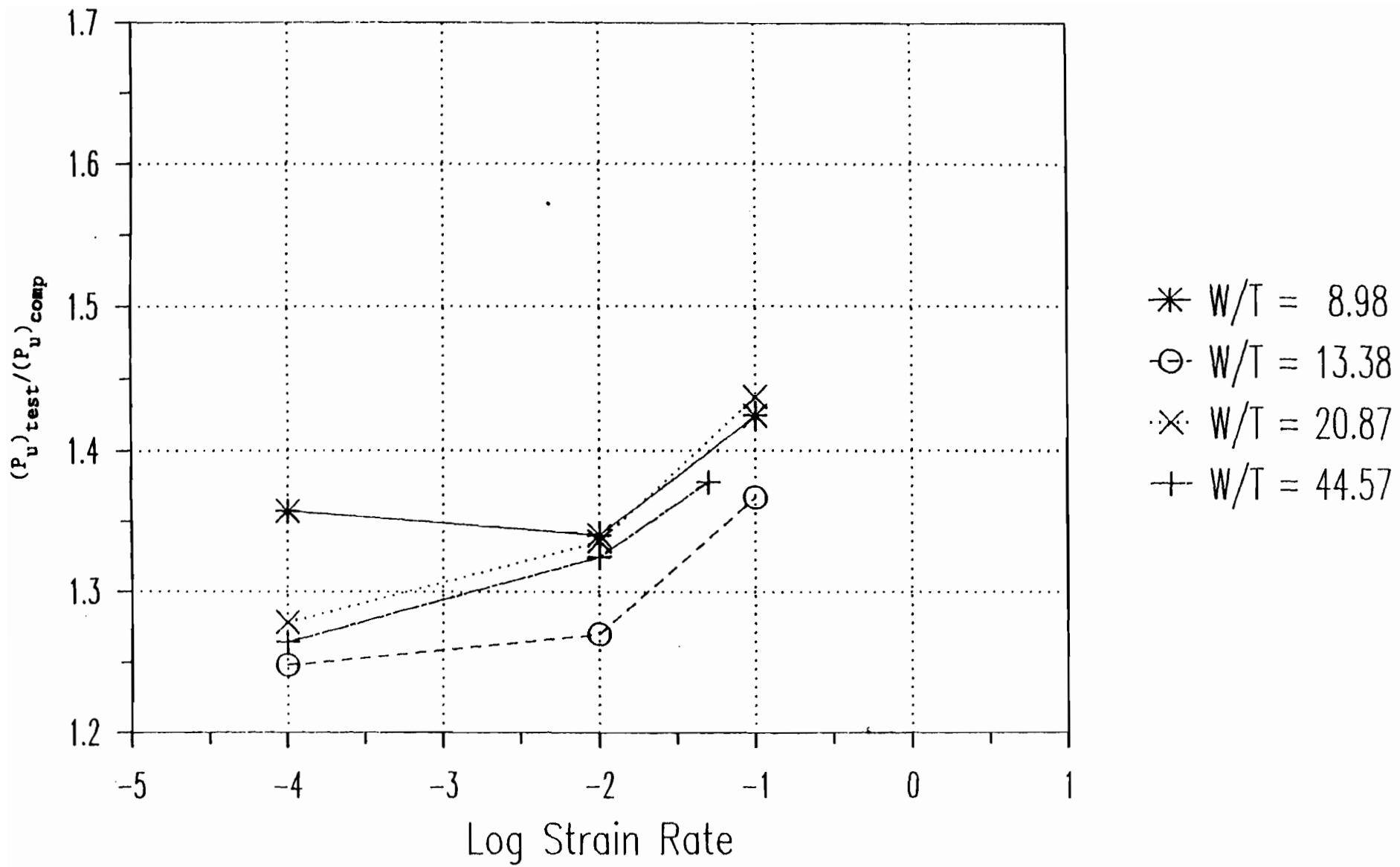

Figure 3.6 Ratios of Tested Ultimate Loads to Computed Ultimate Loads (Based on Dynamic Yield Stresses) vs. Logarithmic Strain Rate for I-Shaped Stub Columns (35XF Sheet Steel)

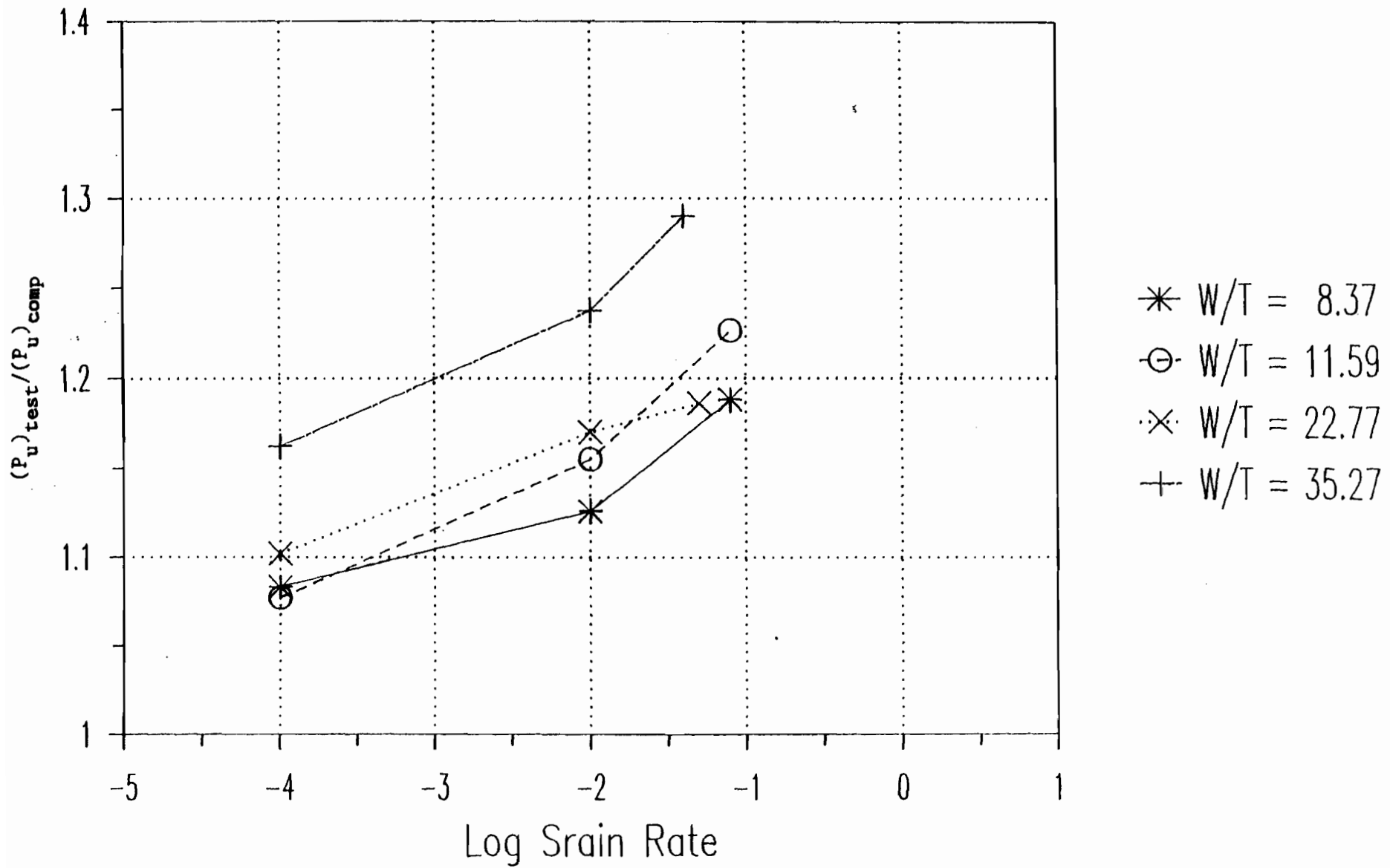

Figure 3.7 Ratios of Tested Ultimate Loads to Computed Ultimate Loads (Based on Static Yield Stress) vs. Logarithmic Strain Rate for I-Shaped Stub Columns (50XF Sheet Steel)

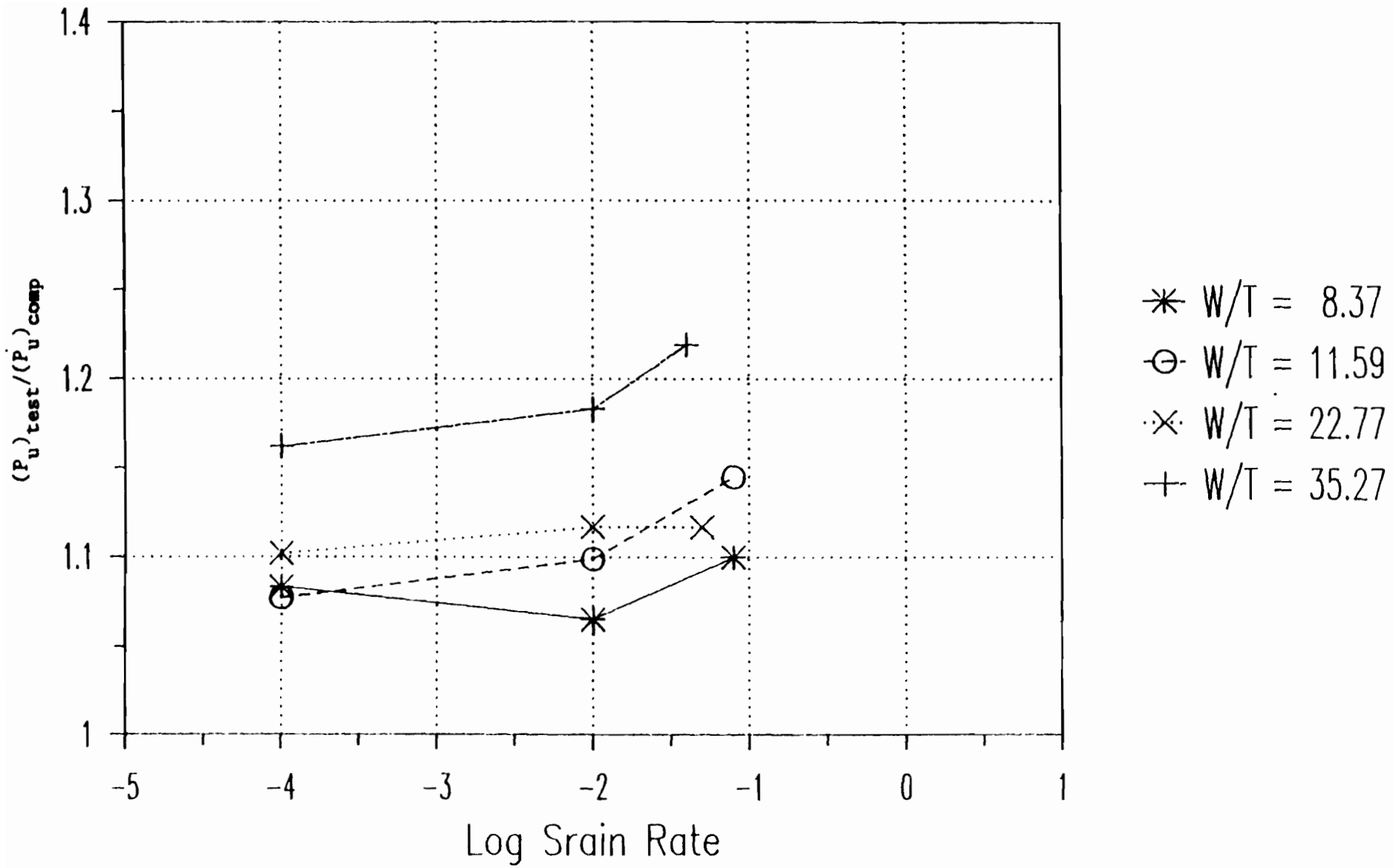

Figure 3.8 Ratios of Tested Ultimate Loads to Computed Ultimate Loads (Based on Dynamic Yield Stresses) vs. Logarithmic Strain Rate for 1-Shaped Stub Columns (50XF Sheet Steel)

## APPENDIX A

## EFFECT OF COLD WORK ON THE AXIAL STRENGTH OF STUB COLUMNS

It is well known that cold-forming operation increases the yield stress and tensile strength of the steel particularly in the corners of cross sections. In order to consider the effect of cold-work on the axial strength of the stub columns, comparisons are made in this appendix between the tested and predicted ultimate loads.

According to the AISI Cold-Formed Steel Design Manual<sup>7</sup>, the strength of a compact section (i.e.  $\rho = 1$ ) including the cold work of forming may be determined by substituting  $F_{ya}$  for  $F_y$ , where  $F_{ya}$  is the average yield stress of the full section, and can be computed as follows :

$$F_{ya} = CF_{yc} + (1-C)F_{yf} \quad (A-1)$$

where

$F_{ya}$  = Average tensile yield stress of steel.

$C$  = Ratio of the total corner cross-sectional area to the total cross-sectional area of the full section.

$F_{yf}$  = Weighted average tensile yield stress of flat portions.

$F_{yc} = B_c F_{yc} / (R/t)^m$ , tensile yield stress of corners. (A-2)

when

$F_{uv}/F_{yv} > 1.2$ ,  $R/t < 7$ , and minimum included angle  $< 120^\circ$

$$B_c = 3.69(F_{uv}/F_{yv}) - 0.819(F_{uv}/F_{yv})^2 - 1.79 \quad (A-3)$$

$$m = 0.192(F_{uv}/F_{yv}) - 0.068 \quad (A-4)$$

R = Inside bend radius.

$F_{yv}$  = Tensile yield stress of virgin steel.

$F_{uv}$  = Ultimate tensile strength of virgin steel.

The predicted ultimate loads ( $(P_u)_{comp}$ ) based on the applicable tensile yield stresses and tested ultimate loads ( $(P_u)_{test}$ ) are presented in Tables 3.3(a)-A and 3.3(b)-A for box-shaped stub columns fabricated from 35XF sheet steel. Tables 3.4(a)-A and 3.4(b)-A present the data for box-shaped stub columns fabricated from 50XF sheet steel. Comparisons of the computed loads based on the static yield stress and the tested ultimate loads are listed in column (7) of Tables 3.3(a)-A and 3.4(a)-A. The mean values of  $(P_u)_{test}/(P_u)_{comp}$  ratios for box-shaped sections made of 35XF and 50XF sheet steels are 1.084 and 0.997 with standard deviations of 0.103 and 0.065, respectively. Comparisons of the computed ultimate loads based on the dynamic yield stresses and the tested ultimate loads are listed in column (7) of Table 3.3(b)-A and 3.4(b)-A. The mean values and standard deviations of  $(P_u)_{test}/(P_u)_{comp}$  ratios are (0.999, 0.052) for using 35XF sheet steel and (0.967, 0.050) for using 50XF sheet steel.

For I-shaped stub columns fabricated from 35XF sheet steel, the predicted ultimate loads based on the applicable tensile yield stresses and the tested ultimate loads are presented in Tables 3.9(a)-A and 3.9(b)-A. Tables 3.10(a)-A and 3.10(b)-A present the data for I-shaped stub columns fabricated from 50XF sheet steel. Comparisons of the



computed loads based on the static yield stress and the tested ultimate loads are listed in column (7) of Tables 3.9(a)-A and 3.10(a)-A. The mean values of  $(P_u)_{\text{test}}/(P_u)_{\text{comp}}$  ratios for I-shaped sections made of 35XF and 50XF sheet steels are 1.264 and 1.141 with standard deviations of 0.120 and 0.087, respectively. Comparisons of the computed ultimate loads based on the dynamic yield stresses and the tested ultimate loads are listed in column (7) of Table 3.9(b)-A and 3.10(b)-A. The mean values and standard deviations of  $(P_u)_{\text{test}}/(P_u)_{\text{comp}}$  ratios are (1.171, 0.060) for using 35XF sheet steel and (1.109, 0.077) for using 50XF sheet steel.

By comparing the ratios of  $(P_u)_{\text{test}}/(P_u)_{\text{comp}}$  presented in these tables and the similar tables included in Chapter III, the following observations can be made :

1. For the box-shaped and I-shaped stub columns with small w/t ratios, a better prediction of the ultimate loads can be obtained by considering the cold work effect. For stub columns with large w/t ratios (i.e.  $\rho < 1$ ), the cold work effect may be neglected.
2. The ultimate load calculated on the basis of the tensile stress gives a better agreement with the tested ultimate load as compared with that calculated by using the compressive yield stress for 35XF sheet steel. However for 50XF sheet steel, because the tensile and compressive yield stresses are practically the same, similar predictions of the ultimate load have been obtained for using compressive and tensile yield stresses.
3. In most cases, the use of dynamic yield stresses improves the prediction of ultimate loads.

Table 3.3(a)-A

Comparison of Computed and Tested Failure Loads Based on the  
Effective Width Formulas in the 1986 AISI Automotive Steel  
Design Manual for Stub Columns with Stiffened Flanges  
(35XF Sheet Steel)  
Based on Static Tensile Yield Stress  
and Considering Cold-Work of Forming

Spec.	Strain Rate (in./in./sec.)	w/t	$(F_y)_t^*$ (ksi)	$A_e$ (in. <sup>2</sup> )	$(P_u)_{comp}$ (kips)	$(P_u)_{test}$ (kips)	$\frac{(6)}{(5)}$ (7)
	(1)	(2)	(3)	(4)	(5)	(6)	(7)
1A1A	0.0001	27.15	36.72	1.2060	44.28	46.12	1.04
1A1B	0.0001	27.39	36.72	1.2058	44.28	44.89	1.01
1A2A	0.01	26.92	36.73	1.2007	44.11	50.02	1.13
1A2B	0.01	27.06	36.73	1.2014	44.13	49.29	1.12
1A3A	0.10	27.31	36.73	1.2009	44.11	53.54	1.21
1A3B	0.10	27.40	36.73	1.2009	44.11	54.37	1.23
1B1A	0.0001	38.93	32.87	1.5432	50.73	49.19	0.97
1B1B	0.0001	39.17	32.87	1.5418	50.68	53.54	1.06
1B2A	0.01	38.86	32.87	1.5373	50.53	56.28	1.11
1B2B	0.01	39.10	32.87	1.5406	50.64	57.01	1.13
1B3A	0.10	38.86	32.87	1.5424	50.70	64.78	1.28
1B3B	0.10	38.96	32.87	1.5393	50.60	60.87	1.20
1C1A	0.0001	52.69	32.87	1.7926	58.92	56.76	0.96
1C1B	0.0001	52.96	32.87	1.7912	58.88	56.52	0.96
1C2A	0.01	52.20	32.87	1.7914	58.88	61.02	1.04
1C2B	0.01	53.06	32.87	1.7936	58.96	64.58	1.10
1C3A	0.10	53.15	32.87	1.7953	59.01	73.96	1.25
1C3B	0.10	53.39	32.87	1.7917	58.89	69.27	1.18
1D1A	0.0001	100.68	32.87	2.0865	68.58	63.85	0.93
1D1B	0.0001	100.35	32.87	2.0905	68.72	63.90	0.93
1D2A	0.01	100.49	32.87	2.0852	68.54	70.35	1.03
1D2B	0.01	100.62	32.87	2.0854	68.55	69.22	1.01
1D3A	0.05	100.85	32.87	2.0836	68.49	74.06	1.08
1D3B	0.05	100.72	32.87	2.0834	68.48	72.45	1.06
Mean							1.084
Standard Deviation							0.103

\* The cold-work effect for 1A sections is considered in the calculation of yield stresses.

Table 3.3(b)-A

Comparison of Computed and Tested Failure Loads Based on the Effective Width Formulas in the 1986 AISI Automotive Steel Design Manual for Stub Columns with Stiffened Flanges (35XF Sheet Steel)  
Based on Dynamic Tensile Yield Stress and Considering Cold-Work of Forming

Spec.	Strain Rate (in./in./sec.)	w/t	$(F_y)_t^*$ (ksi)	$A_e$ (in. <sup>2</sup> )	$(P_u)_{comp}$ (kips)	$(P_u)_{test}$ (kips)	$\frac{(6)}{(5)}$ (7)
1A1A	0.0001	27.15	36.72	1.2060	44.28	46.12	1.04
1A1B	0.0001	27.39	36.72	1.2058	44.28	44.89	1.01
1A2A	0.01	26.92	40.19	1.2007	48.26	50.02	1.04
1A2B	0.01	27.06	40.19	1.2014	48.29	49.29	1.02
1A3A	0.10	27.31	42.84	1.2009	51.45	53.54	1.04
1A3B	0.10	27.40	42.84	1.2009	51.45	54.37	1.06
1B1A	0.0001	38.93	32.87	1.5432	50.73	49.19	0.97
1B1B	0.0001	39.17	32.87	1.5418	50.68	53.54	1.06
1B2A	0.01	38.86	36.40	1.5221	55.41	56.28	1.02
1B2B	0.01	39.10	36.40	1.5253	55.52	57.01	1.03
1B3A	0.10	38.86	39.08	1.5164	59.26	64.78	1.09
1B3B	0.10	38.96	39.08	1.5132	59.13	60.87	1.03
1C1A	0.0001	52.69	32.87	1.7926	58.92	56.76	0.96
1C1B	0.0001	52.96	32.87	1.7912	58.88	56.52	0.96
1C2A	0.01	52.20	36.40	1.7697	64.42	61.02	0.95
1C2B	0.01	53.06	36.40	1.7715	64.48	64.58	1.00
1C3A	0.10	53.15	39.08	1.7579	68.70	73.96	1.08
1C3B	0.10	53.39	39.08	1.7542	68.56	69.27	1.01
1D1A	0.0001	100.68	32.87	2.0865	68.58	63.85	0.93
1D1B	0.0001	100.35	32.87	2.0905	68.72	63.90	0.93
1D2A	0.01	100.49	36.40	2.0543	74.76	70.35	0.94
1D2B	0.01	100.62	36.40	2.0544	74.78	69.22	0.93
1D3A	0.05	100.85	38.21	2.0382	77.88	74.06	0.95
1D3B	0.05	100.72	38.21	2.0381	77.87	72.45	0.93
Mean							0.999
Standard Deviation							0.052

\* The cold-work effect for 1A sections is considered in the calculation of yield stresses.

Table 3.4(a)-A

Comparison of Computed and Tested Failure Loads Based on the Effective Width Formulas in the 1986 AISI Automotive Steel Design Manual for Stub Columns with Stiffened Flanges (50XF Sheet Steel)  
Based on Static Tensile Yield Stress and Considering Cold-Work of Forming

Spec.	Strain Rate (in./in./sec.)	w/t	$(F_y)_t^*$ (ksi)	$A_e$ (in. <sup>2</sup> )	$(P_u)_{comp}$ (kips)	$(P_u)_{test}$ (kips)	$\frac{(6)}{(5)}$ (7)
	(1)	(2)	(3)	(4)	(5)	(6)	(7)
1A1AX	0.0001	22.89	54.38	1.1569	62.91	57.89	0.92
1A1BX	0.0001	23.15	54.35	1.1652	63.32	57.65	0.91
1A2AX	0.01	23.15	54.38	1.1584	62.99	59.82	0.95
1A2BX	0.01	22.94	54.38	1.1587	63.00	60.23	0.96
1A3AX	0.05	23.10	54.37	1.1605	63.10	63.95	1.01
1A3BX	0.05	22.92	54.36	1.1612	63.13	62.04	0.98
1B1AX	0.0001	35.49	49.50	1.2787	63.29	62.19	0.98
1B1BX	0.0001	34.59	49.50	1.2789	63.30	61.75	0.98
1B2AX	0.01	34.50	49.50	1.2778	63.25	68.88	1.09
1B2BX	0.01	34.96	49.50	1.2802	63.37	67.86	1.07
1B3AX	0.04	34.97	49.50	1.2794	63.33	71.42	1.13
1B3BX	0.04	34.79	49.50	1.2813	63.43	71.52	1.13
1C1AX	0.0001	52.76	49.50	1.3305	65.86	60.09	0.91
1C1BX	0.0001	53.40	49.50	1.3342	66.04	60.67	0.92
1C2AX	0.01	53.06	49.50	1.3329	65.98	64.00	0.97
1C2BX	0.01	52.23	49.50	1.3328	65.94	66.44	1.01
1C3AX	0.04	51.67	49.50	1.3298	65.82	66.54	1.01
1C3BX	0.04	52.90	49.50	1.3342	66.04	69.47	1.05
1D1AX	0.0001	97.99	49.50	1.6393	81.15	76.94	0.95
1D2AX	0.01	98.21	49.50	1.6379	81.08	82.22	1.01
1D3AX	0.03	98.01	49.50	1.6424	81.30	82.46	1.01
1D3BX	0.03	98.07	49.50	1.6430	81.33	80.85	0.99
Mean							0.997
Standard Deviation							0.065

\* The cold-work effect for 1A sections is considered in the calculation of yield stresses.

Table 3.4(b)-A

Comparison of Computed and Tested Failure Loads Based on the Effective Width Formulas in the 1986 AISI Automotive Steel Design Manual for Stub Columns with Stiffened Flanges (50XF Sheet Steel)  
Based on Dynamic Tensile Yield Stress and Considering Cold-Work of Forming

Spec.	Strain Rate (in./in./sec.)	w/t	(F <sub>y</sub> ) <sub>t</sub> <sup>*</sup> (ksi)	A <sub>e</sub> (in. <sup>2</sup> )	(P <sub>u</sub> ) <sub>comp</sub> (kips)	(P <sub>u</sub> ) <sub>test</sub> (kips)	$\frac{(6)}{(5)}$ (7)
	(1)	(2)	(3)	(4)	(5)	(6)	(7)
1A1AX	0.0001	22.89	54.38	1.1569	62.91	57.89	0.92
1A1BX	0.0001	23.15	54.35	1.1652	63.32	57.65	0.91
1A2AX	0.01	23.15	56.51	1.1584	65.49	59.82	0.91
1A2BX	0.01	22.94	56.51	1.1587	65.48	60.23	0.92
1A3AX	0.05	23.10	57.51	1.1605	66.74	63.95	0.96
1A3BX	0.05	22.92	57.51	1.1612	66.77	62.04	0.93
1B1AX	0.0001	35.49	49.50	1.2787	63.29	62.19	0.98
1B1BX	0.0001	34.59	49.50	1.2789	63.30	61.75	0.98
1B2AX	0.01	34.50	51.60	1.2731	65.69	68.88	1.05
1B2BX	0.01	34.96	51.60	1.2755	65.81	67.86	1.03
1B3AX	0.04	34.97	52.42	1.2728	66.72	71.42	1.07
1B3BX	0.04	34.79	52.42	1.2748	66.82	71.52	1.07
1C1AX	0.0001	52.76	49.50	1.3305	65.86	60.09	0.91
1C1BX	0.0001	53.40	49.50	1.3342	66.04	60.67	0.92
1C2AX	0.01	53.06	51.60	1.3259	68.42	64.00	0.94
1C2BX	0.01	52.23	51.60	1.3252	68.30	66.44	0.97
1C3AX	0.04	51.67	52.42	1.3203	69.21	66.54	0.96
1C3BX	0.04	52.90	52.42	1.3245	69.43	69.47	1.00
1D1AX	0.0001	97.99	49.50	1.6393	81.15	76.94	0.95
1D2AX	0.01	98.21	51.60	1.6289	84.05	82.22	0.98
1D3AX	0.03	98.01	52.42	1.6308	85.20	82.46	0.97
1D3BX	0.03	98.07	52.42	1.6314	85.23	80.85	0.95
Mean							0.967
Standard Deviation							0.050

\* The cold-work effect for 1A sections is considered in the calculation of yield stresses.

Table 3.9(a)-A

Comparison of Computed and Tested Failure Loads Based on the  
 Effective Width Formulas in the 1986 AISI Automotive Steel  
 Design Manual for Stub Columns with Unstiffened Flanges  
 (35XF Sheet Steel)  
 Based on Static Tensile Yield Stress  
 and Considering Cold-Work of Forming

Spec.	Strain Rate (in./in./sec.)	w/t	$(F_y)_t^*$ (ksi)	$A_e$ (in. <sup>2</sup> )	$(P_u)_{comp}$ (kips)	$(P_u)_{test}$ (kips)	$\frac{(6)}{(5)}$ (7)
	(1)	(2)	(3)	(4)	(5)	(6)	(7)
2A1A	0.0001	8.93	36.60	0.6220	22.77	25.26	1.11
2A1B	0.0001	9.04	36.56	0.6285	22.98	25.35	1.10
2A2A	0.01	8.93	36.56	0.6288	22.99	26.04	1.13
2A2B	0.01	9.10	36.57	0.6275	22.95	27.70	1.21
2A3A	0.10	8.93	36.56	0.6288	22.99	31.41	1.37
2A3B	0.10	8.96	36.58	0.6254	22.88	29.41	1.29
2B1A	0.0001	13.34	32.87	0.9118	29.97	34.20	1.14
2B1B	0.0001	13.41	32.87	0.9052	29.75	34.20	1.15
2B2A	0.01	13.40	32.87	0.9060	29.78	36.30	1.22
2B2B	0.01	13.37	32.87	0.9091	29.88	37.52	1.26
2B3A	0.10	13.34	32.87	0.9109	29.94	41.67	1.39
2B3B	0.10	13.42	32.87	0.9096	29.90	42.70	1.43
2C0A	0.00001	20.69	32.87	0.9666	31.77	36.30	1.14
2C1A	0.0001	20.85	32.87	0.9634	31.67	37.23	1.18
2C1B	0.0001	20.76	32.87	0.9700	31.88	37.66	1.18
2C2A	0.01	20.97	32.87	0.9624	31.63	41.28	1.31
2C2B	0.01	20.81	32.87	0.9697	31.88	41.52	1.30
2C3A	0.10	20.93	32.87	0.9627	31.64	47.92	1.51
2C3B	0.10	20.87	32.87	0.9636	31.67	46.16	1.46
2D1A	0.0001	44.60	32.87	1.0754	35.35	41.72	1.18
2D1B	0.0001	44.50	32.87	1.0768	35.39	41.04	1.16
2D2A	0.01	44.62	32.87	1.0713	35.21	46.31	1.32
2D2B	0.01	44.59	32.87	1.0731	35.27	44.94	1.27
2D3A	0.05	44.51	32.87	1.0649	35.00	48.66	1.39
2D3B	0.05	44.60	32.87	1.0752	35.34	49.39	1.40
Mean							1.264
Standard Deviation							0.120

\* The cold-work effect for 2A sections is considered in the calculation of yield stresses.

Table 3.9(b)-A

Comparison of Computed and Tested Failure Loads Based on the Effective Width Formulas in the 1986 AISI Automotive Steel Design Manual for Stub Columns with Unstiffened Flanges (35XF Sheet Steel)  
Based on Dynamic Tensile Yield Stress and Considering Cold-Work of Forming

Spec.	Strain Rate (in./in./sec.)	w/t	$(F_y)_t^*$ (ksi)	$A_e$ (in. <sup>2</sup> )	$(P_u)_{comp}$ (kips)	$(P_u)_{test}$ (kips)	$\frac{(6)}{(5)}$ (7)
	(1)	(2)	(3)	(4)	(5)	(6)	(7)
2A1A	0.0001	8.93	36.60	0.6220	22.77	25.26	1.11
2A1B	0.0001	9.04	36.56	0.6285	22.98	25.35	1.10
2A2A	0.01	8.93	40.02	0.6288	25.17	26.04	1.03
2A2B	0.01	9.10	40.03	0.6275	25.12	27.70	1.10
2A3A	0.10	8.93	42.67	0.6288	26.83	31.41	1.17
2A3B	0.10	8.96	42.67	0.6254	26.70	29.41	1.10
2B1A	0.0001	13.34	32.87	0.9118	29.97	34.20	1.14
2B1B	0.0001	13.41	32.87	0.9052	29.75	34.20	1.15
2B2A	0.01	13.40	36.40	0.8953	32.59	36.30	1.11
2B2B	0.01	13.37	36.40	0.8948	32.70	37.52	1.15
2B3A	0.10	13.34	39.08	0.8926	34.88	41.67	1.19
2B3B	0.10	13.42	39.08	0.8911	34.82	42.70	1.23
2C0A	0.00001	20.69	32.02	0.9709	31.09	36.30	1.17
2C1A	0.0001	20.85	32.87	0.9634	31.67	37.23	1.18
2C1B	0.0001	20.76	32.87	0.9700	31.88	37.66	1.18
2C2A	0.01	20.97	36.40	0.9458	34.43	41.28	1.20
2C2B	0.01	20.81	36.40	0.9532	34.70	41.52	1.20
2C3A	0.10	20.93	39.08	0.9348	36.53	47.92	1.31
2C3B	0.10	20.87	39.08	0.9357	36.57	46.16	1.26
2D1A	0.0001	44.60	32.87	1.0754	35.35	41.72	1.18
2D1B	0.0001	44.50	32.87	1.0768	35.39	41.04	1.16
2D2A	0.01	44.62	36.40	1.0493	38.19	46.31	1.21
2D2B	0.01	44.59	36.40	1.0511	38.26	44.94	1.17
2D3A	0.05	44.51	38.21	1.0327	39.46	48.66	1.23
2D3B	0.05	44.60	38.21	1.0430	39.85	49.39	1.24
Mean							1.171
Standard Deviation							0.060

\* The cold-work effect for 2A sections is considered in the calculation of yield stresses.

Table 3.10(a)-A

Comparison of Computed and Tested Failure Loads Based on the Effective Width Formulas in the 1986 AISI Automotive Steel Design Manual for Stub Columns with Unstiffened Flanges (50XF Sheet Steel)  
Based on Static Tensile Yield Stress and Considering Cold-Work of Forming

Spec.	Strain Rate (in./in./sec.)	w/t	$(F_y)_t^*$ (ksi)	$A_e$ (in. <sup>2</sup> )	$(P_u)_{comp}$ (kips)	$(P_u)_{test}$ (kips)	$\frac{(6)}{(5)}$ (7)
2A1AX	0.0001	8.41	54.91	0.5220	28.66	28.04	1.00
2A1BX	0.0001	8.38	54.90	0.5227	28.70	28.16	0.98
2A2AX	0.01	8.40	54.90	0.5228	28.70	29.02	1.01
2A2BX	0.01	8.38	54.90	0.5224	28.69	29.43	1.03
2A3AX	0.08	8.29	54.90	0.5232	28.72	30.75	1.07
2A3BX	0.08	8.36	54.90	0.5227	28.70	30.95	1.08
2B1AX	0.0001	11.68	49.50	0.7358	36.42	39.72	1.09
2B1BX	0.0001	11.60	49.50	0.7399	36.63	39.18	1.07
2B1CX	0.00001	11.63	49.50	0.7404	36.65	39.47	1.08
2B2AX	0.01	11.58	49.50	0.7407	36.67	42.60	1.16
2B2BX	0.01	11.54	49.50	0.7442	36.84	42.55	1.15
2B2CX	0.001	11.53	49.50	0.7384	36.55	41.77	1.14
2B3AX	0.08	11.65	49.50	0.7394	36.60	45.07	1.23
2B3BX	0.08	11.50	49.50	0.7393	36.59	44.94	1.23
2C1AX	0.0001	22.84	49.50	0.7989	39.55	43.62	1.10
2C1BX	0.0001	22.73	49.50	0.8019	39.70	43.97	1.11
2C2AX	0.01	22.77	49.50	0.7994	39.57	46.70	1.18
2C2BX	0.01	22.76	49.50	0.8009	39.65	46.26	1.17
2C3AX	0.05	22.72	49.50	0.7984	39.52	47.34	1.20
2C3BX	0.05	22.79	49.50	0.8007	39.63	46.85	1.18
2D1AX	0.0001	35.37	49.50	0.7675	37.99	44.06	1.16
2D1BX	0.0001	35.33	49.50	0.7674	37.99	44.50	1.17
2D2AX	0.01	35.26	49.50	0.7677	38.00	46.75	1.23
2D2BX	0.01	35.21	49.50	0.7681	38.02	47.58	1.25
2D3AX	0.04	35.29	49.50	0.7671	37.97	49.39	1.30
2D3BX	0.04	35.15	49.50	0.7685	38.04	48.95	1.29
Mean							1.141
Standard Deviation							0.087

\* The cold-work effect for 2A sections is considered in the calculation of yield stresses.



Table 3.10(b)-A

Comparison of Computed and Tested Failure Loads Based on the Effective Width Formulas in the 1986 AISI Automotive Steel Design Manual for Stub Columns with Unstiffened Flanges (50XF Sheet Steel)  
Based on Dynamic Tensile Yield Stress and Considering Cold-Work of Forming

Spec.	Strain Rate (in./in./sec.)	w/t	$(F_y)_t^*$ (ksi)	$A_e$ (in. <sup>2</sup> )	$(P_u)_{comp}$ (kips)	$(P_u)_{test}$ (kips)	$\frac{(6)}{(5)}$ (7)
	(1)	(2)	(3)	(4)	(5)	(6)	(7)
2A1AX	0.0001	8.41	54.91	0.5220	28.66	28.04	1.00
2A1BX	0.0001	8.38	54.90	0.5227	28.70	28.16	0.98
2A2AX	0.01	8.40	57.04	0.5228	29.82	29.02	0.97
2A2BX	0.01	8.38	57.04	0.5224	29.80	29.43	0.99
2A3AX	0.08	8.29	58.37	0.5232	30.54	30.75	1.01
2A3BX	0.08	8.36	58.37	0.5227	30.52	30.95	1.01
2B1AX	0.0001	11.68	49.50	0.7358	36.42	39.72	1.09
2B1BX	0.0001	11.60	49.50	0.7399	36.63	39.18	1.07
2B1CX	0.00001	11.63	48.81	0.7415	36.19	39.47	1.09
2B2AX	0.01	11.58	51.60	0.7376	38.06	42.60	1.12
2B2BX	0.01	11.54	51.60	0.7411	38.24	42.55	1.11
2B2CX	0.001	11.53	50.43	0.7370	37.17	41.77	1.12
2B3AX	0.08	11.65	52.86	0.7344	38.82	45.07	1.16
2B3BX	0.08	11.50	52.86	0.7343	38.82	44.94	1.16
2C1AX	0.0001	22.84	49.50	0.7989	39.55	43.62	1.10
2C1BX	0.0001	22.73	49.50	0.8019	39.70	43.97	1.11
2C2AX	0.01	22.77	51.60	0.7941	40.98	46.70	1.14
2C2BX	0.01	22.76	51.60	0.7957	41.06	46.26	1.13
2C3AX	0.05	22.72	52.56	0.7908	41.56	47.34	1.14
2C3BX	0.05	22.79	52.56	0.7931	41.69	46.85	1.12
2D1AX	0.0001	35.37	49.50	0.7675	37.99	44.06	1.16
2D1BX	0.0001	35.33	49.50	0.7674	37.99	44.50	1.17
2D2AX	0.01	35.26	51.60	0.7617	39.20	46.75	1.19
2D2BX	0.01	35.21	51.60	0.7621	39.22	47.58	1.21
2D3AX	0.04	35.29	52.42	0.7588	39.78	49.39	1.24
2D3BX	0.04	35.15	52.42	0.7602	39.85	48.95	1.23
Mean							1.109
Standard Deviation							0.077

\* The cold-work effect for 2A sections is considered in the calculation of yield stresses.

## APPENDIX B

## NOTATION

The following symbols are used in this report:

$A_e$	Effective cross-sectional area of stub columns
$A_t$	Cross-sectional area of stub columns
$b$	Effective width of a compression element
$C$	Ratio of the total corner cross-sectional area to the total cross-sectional area of the full section
$D$	Flexural rigidity of plate
$E$	Modulus of elasticity of steel, 29,500 ksi
$f$	Edge stress in the compression element
$f_{cr}$	Critical local buckling stress
$(f_{cr})_E$	Elastic critical local buckling stress
$(f_{cr})_I$	Inelastic critical local buckling stress
$f_x$	Stress component normal to the edges of the plate
$F_{pr}$	Proportional limit
$F_y$	Yield stress
$F_{ya}$	Average tensile yield stress of steel
$F_{yc}$	Corner yield stress
$F_{yf}$	Weighted average tensile stress point of flat portions
$F_{yv}$	Tensile yield stress of virgin steel
$(F_y)_c$	Compressive yield stress
$(F_y)_t$	Tensile yield stress
$F_u$	Ultimate tensile strength
$F_{uv}$	Ultimate tensile strength of virgin steel
$k$	Buckling coefficient

$P_{cr}$	Critical local buckling load
$(P_{cr})_{comp}$	Computed critical local buckling load
$(P_{cr})_{test}$	Tested critical local buckling load
$P_u$	Ultimate load
$(P_u)_{comp}$	Computed ultimate load
$(P_u)_{test}$	Tested ultimate load
$R$	Inside bend radius
$t$	Thickness of element
$w$	Flat width of a compression element
$\lambda$	Slenderness factor
$\omega$	Lateral deflection of the plate
$\mu$	Poisson's ratio
$\rho$	Reduction factor