28 Jun 2006

Compact Autonomous Explosive-Driven Pulsed Power System Based on a Capacitive Energy Storage Charged by a High-Voltage Shock-Wave Ferromagnetic Generator

S. I. Shkuratov

E. F. Talantsev

Jason Baird

Missouri University of Science and Technology, jbaird@mst.edu

Larry L. Altgilbers

et. al. For a complete list of authors, see https://scholarsmine.mst.edu/min_nuceng_facwork/41

Follow this and additional works at: https://scholarsmine.mst.edu/min_nuceng_facwork



Part of the [Explosives Engineering Commons](#)

Recommended Citation

S. I. Shkuratov et al., "Compact Autonomous Explosive-Driven Pulsed Power System Based on a Capacitive Energy Storage Charged by a High-Voltage Shock-Wave Ferromagnetic Generator," *Review of Scientific Instruments*, vol. 77, American Institute of Physics (AIP), Jun 2006.

The definitive version is available at <https://doi.org/10.1063/1.2205157>

This Article - Journal is brought to you for free and open access by Scholars' Mine. It has been accepted for inclusion in Mining Engineering Faculty Research & Creative Works by an authorized administrator of Scholars' Mine. This work is protected by U. S. Copyright Law. Unauthorized use including reproduction for redistribution requires the permission of the copyright holder. For more information, please contact scholarsmine@mst.edu.

Compact autonomous explosive-driven pulsed power system based on a capacitive energy storage charged by a high-voltage shock-wave ferromagnetic generator

Sergey I. Shkuratov,^{a)} Evgueni F. Talantsev, and Jason Baird
Loki Incorporated, Rolla, Missouri 65409

Larry L. Altgilbers
U.S. Army Space and Missile Defense Command, Huntsville, Alabama 35807

Allen H. Stults
U.S. Army Aviation and Missile Research, Development and Engineering Center, Huntsville,
Alabama 35898

(Received 5 November 2005; accepted 24 April 2006; published online 28 June 2006)

A new concept for constructing compact autonomous pulsed power systems is presented. This concept utilizes a high-voltage explosive-driven shock-wave ferromagnetic generator (FMG) as a charging source for capacitive energy storage. It has been experimentally demonstrated that miniature FMGs (22–25 cm³ in size and 84–95 g in mass) developed for these experiments can be successfully used to charge capacitor banks. The FMGs, containing Nd₂Fe₁₄B energy-carrying elements, provided pulsed powers of 35–45 kW in times ranging from 10 to 15 μ s. A methodology was developed for digital simulation of the operation of the transverse FMG. Experimental results that were obtained are in a good agreement with the results of digital simulations. © 2006 American Institute of Physics. [DOI: 10.1063/1.2205157]

A variety of pulsed power devices based on capacitive energy storage are widely used in modern technology. In traditional Arkadiev-Marx-type generators electrical energy is provided to a capacitive energy storage “bank” from high-voltage power sources powered from a conventional 110/220 V–50/60 Hz supply line.¹ Certain special applications, however, require that the pulsed power system be autonomous. Another necessary condition is compactness of the system as a whole. Autonomous Arkadiev-Marx-type generators utilize electrochemical cells as primary power sources.² The cells are not small, and such devices require a high-voltage converter to produce high voltage for charging a capacitor bank.

Explosive-driven electrical generators are the most efficient autonomous pulsed power devices available today.³ Currently, several new types of autonomous compact explosive-driven primary power sources are under development.^{4–8} In this article, we propose a new concept of explosive-driven autonomous pulsed power systems. This concept utilizes a high-voltage shock-wave ferromagnetic generator (FMG) as a charging source for capacitive energy storage.

An advantage of a shock-wave FMG in comparison with explosive-driven primary sources of other types is the lack of direct electrical connection between the ferromagnetic energy-carrying element and pulse-generating system of the device. The ferromagnet is electrically insulated from the pulse-generating system and there is a transformer-type coupling only between the ferromagnet and pulse-generating

coil. Therefore, the pulse-generating coil of the FMG is not subjected to explosive shock during the demagnetization time; it does not change its electrical parameters during operation.

One of the problems associated with the operation of explosive-driven electrical generators is the destructive action of the explosive charge on the pulse-generating system of the device and its related electronic circuit.³ The lifetime of transverse shock-wave ultracompact high-voltage FMGs based on our previous designs did not exceed 12 μ s.⁷ Our main objective in designing a miniature high-voltage FMG for charging a capacitor bank was to develop a pulsed power system that operates reliably, i.e., to decrease the effect of the explosive charge on the system, to improve its high-voltage insulation, and to extend its lifetime up to 50 μ s.

The developed design of an FMG is shown in Fig. 1. We introduced a pulse-generating coil holder that protects the pulsed power circuit of the generator against the mechanical action of the explosive charge for a few tens of microseconds. In addition, it provides electrical insulation between the pulse-generating coils and the magnets (which are connected to the electrical ground potential via detonator wires). However, introduction of the cylindrical insulator into the system lowers the efficiency of the pulse-generating system. Increasing the distance between the ferromagnet and the pulse-generating coil reduces the magnetic flux captured by each pulse-generating turn and results in the production of a lower electromotive force. In a series of explosive experiments, we determined that the optimum thickness of the insulator is 1.5 mm. A further increase in the thickness does not improve reliability of the system but does decrease the efficiency of the FMG. We tried two different materials

^{a)} Author to whom correspondence should be addressed; electronic mail: shkuratov@lokiconsult.com

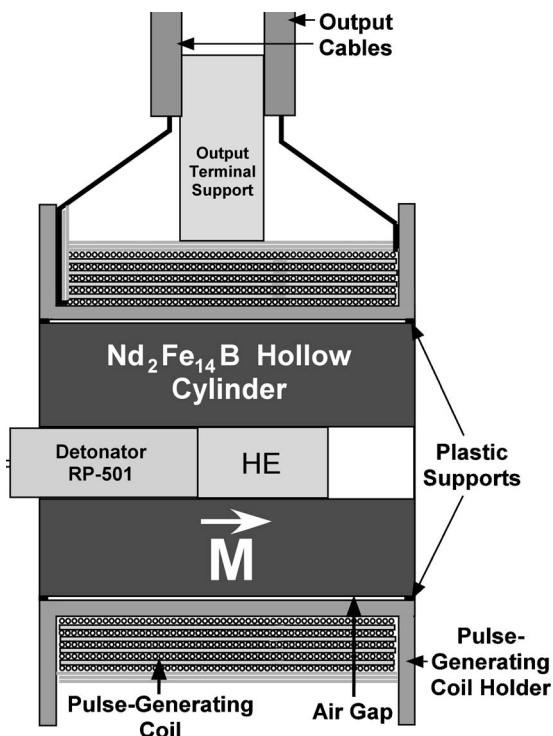

FIG. 1. Schematic diagram of a high-voltage transverse FMG.

(Lexan® and ultra-high-molecular-weight polyethylene) for cylindrical coil holder. Both materials worked well. We also introduced a 0.75 mm air gap between the ferromagnetic energy-carrying element and the insulator (Fig. 1) to reduce shock-wave propagation to the plastic insulator.

All generators contained $\text{Nd}_2\text{Fe}_{14}\text{B}$ (grade 35) energy-carrying elements of outer diameter $\text{OD}=22.2$ mm, inside diameter $\text{ID}=9.0$ mm, and length $h=25.4$ mm. Magnetic parameters of the $\text{Nd}_2\text{Fe}_{14}\text{B}$ are residual flux density $B_r=1.23$ T, coercive force $H_c=8.99 \times 10^5$ A/m, and maximum energy product $BH_{\text{max}}=0.279$ J/cm³. Information about the experimental setup that we used in our explosive experiments is in Refs. 4 and 5.

The basis for the production of high voltage at the output terminals of FMG is Faraday's law that is related to the decrease in the initial magnetic flux in the ferromagnetic energy-carrying element due to shock-wave action. For a multiturn coil, the generated electromotive force (EMF) is the sum of the EMFs produced by all the turns,

$$E_{\text{multiturn}}(t) = \sum_N [-d\Phi_n(t)/dt], \quad (1)$$

where dt is the time in which the magnetic flux changes in the turn, $d\Phi_n(t)$ is the magnetic flux captured by the n th turn of the multiturn coil, and N is the number of turns in the coil.

The typical EMF wave form produced by an FMG is shown in Fig. 2(a). The generator contained a 231-turn coil (AWG28 magnet wire of diameter 0.35 mm) with an inner diameter of 27 mm and an outer diameter of 33 mm. Overall length and diameter of the generators were 2.6 and 3.4 cm, respectively (23.6 cm³ volume). The average total weight of the devices was 92 g. The serial resistance and serial inductance of the FMG at 100 kHz were R_S (100 kHz)=19.4 Ω and L_S (100 kHz)=1.82 mH, respectively. The generator ex-

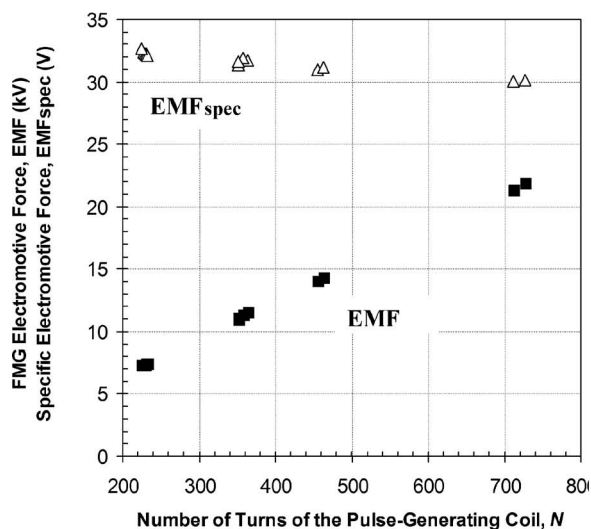
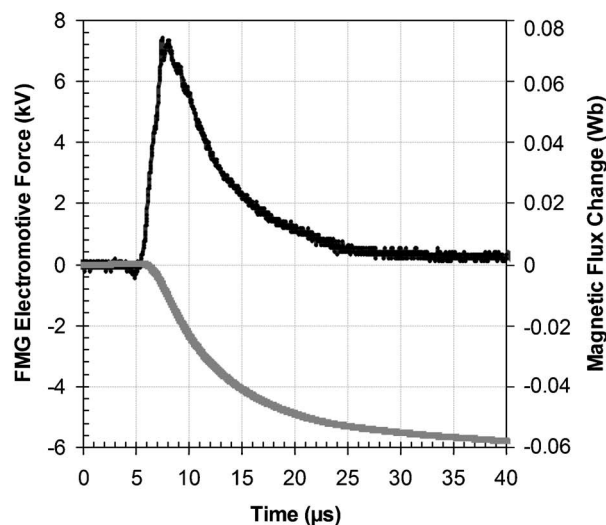

FIG. 2. Wave form of the EMF pulse (black) produced by an FMG containing a 231-turn pulse-generating coil and the corresponding time history of the change of magnetic flux $\Delta\Phi(t)$ (gray) (a). EMF peak amplitude and peak specific EMF vs the number of turns of the pulse-generating coil (b).

plosive charge was 0.6 g of C-4 high explosives and the charge was initiated by a single RISI RP-501 detonator.

The peak amplitude of the EMF pulse is $E_{\text{multiturn}}(t)_{\text{max}}=7.45$ kV, with a full width at half maximum (FWHM) of 5.8 μs and a rise time $\tau=2.6$ μs . There are no breaks or distortions in the EMF pulse wave form. After the main pulse, there is a long tail with amplitude of about 300 V. The EMF specific peak was $E_{\text{multiturn}}(t)_{\text{max spec}}=32.2$ V/turn. The specific EMF peak averaged from seven experiments was $E_{\text{multiturn}}(t)_{\text{max spec}}=31.1 \pm 1.4$ V/turn.

Figure 2(a) also shows the time history in the FMG of the magnetic flux change $\Delta\Phi(t)$, which was obtained by integrating the experimental wave form of the output voltage pulse,

$$\Delta\Phi(t) = - \int_0^t E_{\text{multiturn}}(t) dt. \quad (2)$$

The final magnetic flux change was $\Delta\Phi(\infty)=\Delta\Phi_{\text{fin}}=58$ mWb (Fig. 2), and the specific magnetic flux change in this experiment was $\Delta\Phi_{\text{fin spec}}=251$ $\mu\text{Wb/turn}$. The value of

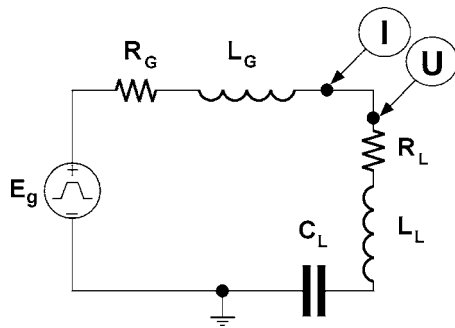

FIG. 3. Equivalent circuit diagram of the FMG employed in the simulation.

the specific magnetic flux change in the FMGs obtained in seven experiments was $\Delta\Phi_{\text{fin spec}} = 231 \pm 20 \mu\text{Wb/turn}$.

Earlier,⁵⁻⁸ we developed a methodology for calculation of the initial magnetic flux Φ_0 of $\text{Nd}_2\text{Fe}_{14}\text{B}$ energy-carrying elements. The calculated value of the initial magnetic flux in the cross section of the pulse-generating coil is $\Phi_0 = 269 \mu\text{Wb}$. Comparing the experimentally obtained specific magnetic flux change in the FMG, $\Delta\Phi_{\text{fin spec}}$, to the initial value of the magnetic flux, Φ_0 , we concluded that more than 85% of initial magnetic flux stored in the $\text{Nd}_2\text{Fe}_{14}\text{B}$ hard ferromagnet was transformed into the high-voltage pulse.

We performed several series of experiments with FMGs containing different numbers of turns in the pulse-generating coil. The EMF pulse wave forms were very reproducible; Fig. 2(b) shows EMF peak amplitude and peak specific EMF versus the number of turns in the pulse-generating coil. It follows from our experimental results that the EMF peak amplitude is directly proportional to the number of turns. The FMG containing a 727-turn coil is capable of producing a 21.9 kV pulse.

In this work, we have developed a methodology for simulating the operation of high-voltage FMGs used as primary power sources for charging capacitive energy storage devices. The calculation was based on using PSPICE code.⁹ The equivalent circuit diagram of the FMG employed in these simulations is shown in Fig. 3. It contains the pulsed electromotive force, the inductance L_G and the resistance R_G of the FMG, the inductance L_L , the resistance R_L , and the capacitance of the capacitor bank, C_L , connected in series. The capacitance of the pulse-generating coil was so low as to be negligible. The circuit also contains the probes that measure the current $I(t)$ in the system and the voltage across the capacitor, $U(t)$ (I probe and U probe, respectively). We digitized the normalized electromotive force and introduced it into the “Source” section of the code.

Figure 4(a) shows an example of the simulation results. It is the calculated wave form of the high voltage across a capacitor bank of capacitance $C_L = 18 \text{ nF}$ produced by an FMG containing a pulse-generating coil with $N = 231$ turns. The $L_G(100 \text{ KHz}) = 1.82 \text{ mH}$ and the $R_G(100 \text{ KHz}) = 19.4 \Omega$. The amplitude of the calculated high-voltage pulse is 6.6 kV, and the high-voltage pulse rise time is $16 \mu\text{s}$. The calculated current amplitude ranges from 10 to 14 A.

In our experiments we used 1.8 nF ceramic capacitors, each with a nominal voltage of 6 kV. These capacitors are the same that we intend to use in completely expendable systems.¹⁰ We combined the capacitors into capacitor modules, with each capacitor module containing five ceramic ca-

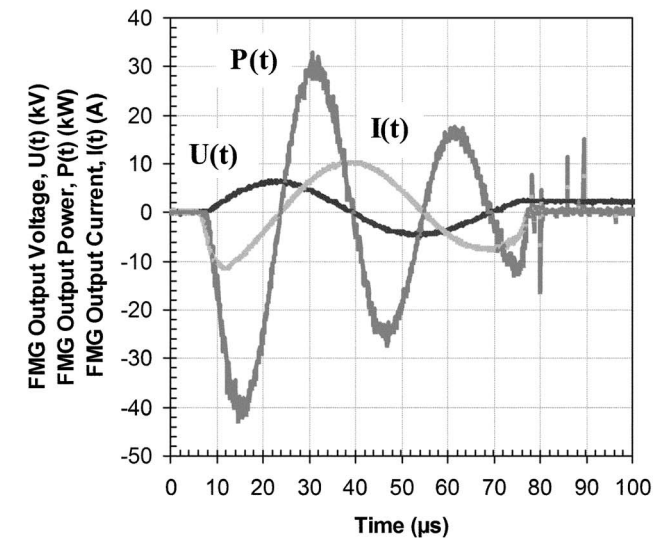
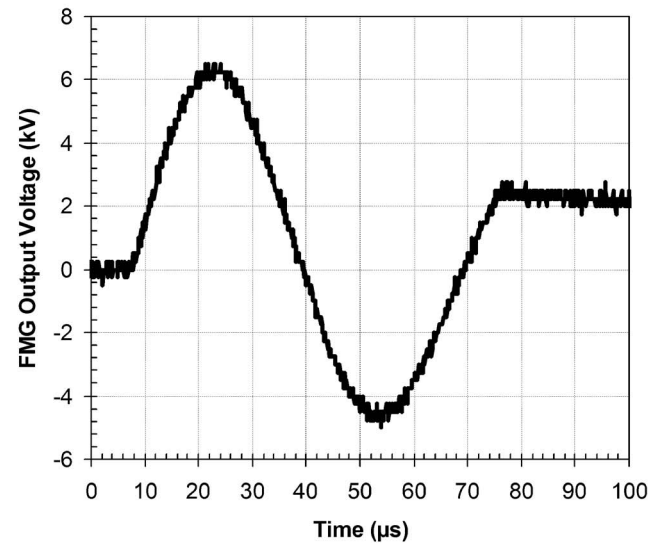
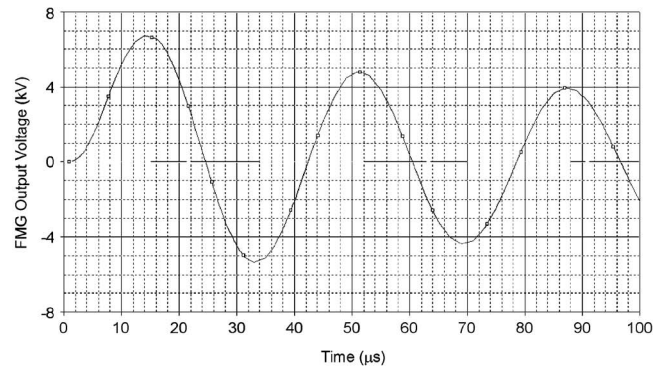

FIG. 4. Wave form of the output voltage pulse produced by the FMG connected to an 18 nF capacitor bank. The pulse-generating coil of the FMG contained 252 turns. (a) Calculated output high-voltage wave form, $U(t)$; (b) experimental output high-voltage wave form, $U(t)$; and (c) experimental output waveforms of current $I(t)$ (light gray), voltage $U(t)$ (dark gray), and power $P(t)$ (black).

pacitors connected in parallel. Each capacitor bank, placed in the measuring box, contained a certain number of capacitor modules, enough to create the desired capacitance and nominal voltage of the complete bank.

The wave form of the high voltage pulse produced by an FMG containing a 252-turn pulse-generating coil across an 18 nF capacitor bank is shown in Fig. 4(b). The amplitude of the voltage pulse was $U(t)_{\max}=6.5$ kV and its rise time was $\tau=15.2$ μ s. There is very good agreement between the results obtained by the digital simulations and the experimental data [Figs. 4(a) and 4(b)]. The energy delivered to the capacitor bank was $W(t)_{\max}=0.38$ J [$W(t)_{\max}=C_0U(t)_{\max}^2/2$].

The corresponding pulses of current $I(t)$, voltage $U(t)$, and power $P(t)$ for this experiment are in Fig. 4(c). The output power $P(t)$ was determined as the product of the instantaneous value of the output voltage $U(t)$ and the instantaneous current in the circuit, $I(t)$: $P(t)=I(t)U(t)$. The peak power reached $P(t)_{\max}=43$ kW.

From the voltage and current wave forms, we can determine the time to destruction of the pulse-generating system of the FMG; it is about 75 μ s. Therefore, the time of operation of the FMG is five times longer than needed to charge the capacitor bank [$\tau=15.2$ μ s in Figs. 4(b) and 4(c)].

We have shown that it is fundamentally possible to construct a completely autonomous explosive-driven high-voltage pulsed power system based on a high-voltage transverse shock-wave ferromagnetic generator and capacitive energy storage.

¹C. N. Boyer, G. E. Holand, and J. F. Seely, *Rev. Sci. Instrum.* **76**, 035109 (2005).

²B. A. Jacoby and T. M. York, *Rev. Sci. Instrum.* **51**, 885 (1980).

³L. L. Altgilbers, M. D. J. Brown, I. Grishnaev, B. M. Novac, I. R. Smith, I. Tkach, and Yu. Tkach, *Magnetocumulative Generators* (Springer-Verlag, New York, 2000).

⁴S. I. Shkuratov, E. F. Talantsev, L. Menon, H. Temkin, J. Baird, and L. L. Altgilbers, *Rev. Sci. Instrum.* **75**, 2766 (2004).

⁵S. I. Shkuratov and E. F. Talantsev, *Electromagn. Phenom.* **3**, 452 (2003).

⁶S. I. Shkuratov, E. F. Talantsev, J. C. Dickens, M. Kristiansen, and J. Baird, *Appl. Phys. Lett.* **82**, 1248 (2003).

⁷S. I. Shkuratov, E. F. Talantsev, J. C. Dickens, and M. Kristiansen, *Rev. Sci. Instrum.* **73**, 2738 (2002).

⁸S. I. Shkuratov, E. F. Talantsev, J. C. Dickens, and M. Kristiansen, *J. Appl. Phys.* **93**, 4529 (2003).

⁹PSPICE PCB, www.pspicepcb.com

¹⁰S. I. Shkuratov, E. F. Talantsev, L. L. Hatfield, J. C. Dickens, and M. Kristiansen, *IEEE Trans. Plasma Sci.* **30**, 1943 (2002).