

01 Jan 1978

Phase 1 Inspection Report: National Dam Safety Program. Osage - Gasconade Basin. Little Prairie Dam, Phelps County, Missouri

Anderson Engineering, Inc., Springfield, Missouri

Hanson Engineers, Inc., Springfield, Illinois

Follow this and additional works at: <https://scholarsmine.mst.edu/dam-reports>



Part of the [Civil and Environmental Engineering Commons](#)

Recommended Citation

Anderson Engineering, Inc., Springfield, Missouri and Hanson Engineers, Inc., Springfield, Illinois, "Phase 1 Inspection Report: National Dam Safety Program. Osage - Gasconade Basin. Little Prairie Dam, Phelps County, Missouri" (1978). *Missouri Dam Safety Inspection Reports*. 8.
<https://scholarsmine.mst.edu/dam-reports/8>

This Technical Report is brought to you for free and open access by Scholars' Mine. It has been accepted for inclusion in Missouri Dam Safety Inspection Reports by an authorized administrator of Scholars' Mine. This work is protected by U. S. Copyright Law. Unauthorized use including reproduction for redistribution requires the permission of the copyright holder. For more information, please contact scholarsmine@mst.edu.

OSAGE - GASCONADE BASIN

LITTLE PRAIRIE DAM
PHELPS COUNTY, MISSOURI
MO 30090

MO. GEOL SURVEY LIBRARY

PHASE I INSPECTION REPORT NATIONAL DAM SAFETY PROGRAM

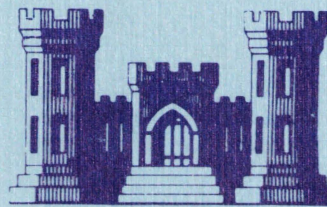

Non-Depository Item
AUG 18 REC'D
University of Missouri Rolla
Federal Depository # 0332

PREPARED BY: U. S. ARMY ENGINEER DISTRICT, ST. LOUIS

FOR: STATE OF MISSOURI

DECEMBER 1978



DEPARTMENT OF THE ARMY
ST. LOUIS DISTRICT, CORPS OF ENGINEERS
210 NORTH 12TH STREET
ST. LOUIS, MISSOURI 63101

IN REPLY REFER TO

SUBJECT: Little Prairie Dam Phase I Inspection Report

This report presents the results of field inspection and evaluation of the Little Prairie Dam. It was prepared under the National Program of Inspection of Non-Federal Dams.

SUBMITTED BY:

SIGNED

Chief, Engineering Division

28 FEB 1979

Date

APPROVED BY:

SIGNED

Colonel, CE, District Engineer

28 FEB 1979

Date

LITTLE PRAIRIE DAM
PHELPS COUNTY, MISSOURI
MISSOURI INVENTORY NO. 30090

PHASE I INSPECTION REPORT
NATIONAL DAM SAFETY PROGRAM

Prepared By

Anderson Engineering, Inc., Springfield, Missouri
Hanson Engineers, Inc., Springfield, Illinois

For

The Governor of Missouri

December, 1978

PHASE I REPORT
NATIONAL DAM SAFETY PROGRAM

Name of Dam: Little Prairie Dam
State Located: Missouri
County Located: Phelps County
Stream: Unnamed Tributary to Bourbeuse River
Date of Inspection: 24 August 1978

Little Prairie Dam was inspected by an interdisciplinary team of engineers from Anderson Engineering, Inc. of Springfield, Missouri and Hanson Engineers, Inc. of Springfield, Illinois. The purpose of the inspection was to make an assessment of the general condition of the dam with respect to safety, based upon available data and visual inspection, in order to determine if the dam poses hazards to human life or property.

The guidelines used in the assessment were furnished by the Department of the Army, Office of the Chief of Engineers and they have been developed with the help of several Federal and State agencies, professional engineering organizations, and private engineers. Based on these guidelines, this dam has been classified by the St. Louis District Corps of Engineers as an intermediate size dam with a high downstream hazard potential. Should the dam fail, their estimate of the damage zone extends 5 miles downstream of the dam. Within the first mile of the damage zone are two houses, one mobile home and three improved road bridges.

Our inspection and evaluation indicates that the combined spillways do not meet the criteria set forth in the guidelines for a dam having the above size and hazard potential. The combined spillways will pass 39 percent of the Probable Maximum Flood without overtopping. The guidelines require that a dam of intermediate size with a high downstream hazard potential pass 100 percent of the PMF. The spillways will pass the 100-year flood.

The embankment and appurtenances inspected appear to be in good condition. Minor deficiencies, including erosion, and brush and tree growth were noted and should be corrected by the owner. Another deficiency was the lack of seepage and stability analyses. A detailed report is attached to be submitted to the owners and to the Governor of Missouri.

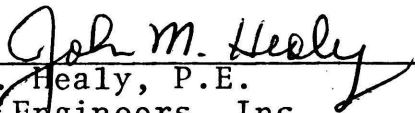
John M. Healy, P.E.
Hanson Engineers, Inc.

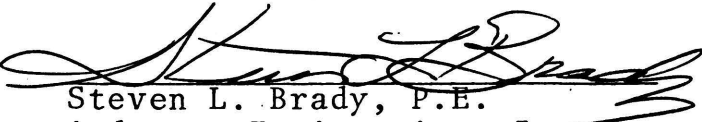
Steven L. Brady, P.E.
Anderson Engineering, Inc.

PHASE I INSPECTION REPORT
NATIONAL DAM SAFETY PROGRAM
LITTLE PRAIRIE DAM - ID No. 30090

TABLE OF CONTENTS

| <u>Paragraph No.</u> | <u>Title</u> | <u>Page No.</u> |
|------------------------------------------|------------------------------------------------|---------------------|
| SECTION 1 - PROJECT INFORMATION | | |
| 1.1 | General | 1 |
| 1.2 | Description of the Project | 1 |
| 1.3 | Pertinent Data | 3 |
| SECTION 2 - ENGINEERING DATA | | |
| 2.1 | General | 5 |
| 2.2 | Design | 5 |
| 2.3 | Operation | 7 |
| 2.4 | Evaluation | 7 |
| SECTION 3 - VISUAL INSPECTION | | |
| 3.1 | General | 8 |
| 3.2 | Dam | 8 |
| 3.3 | Reservoir and Watershed | 9 |
| 3.4 | Evaluation | 9 |
| SECTION 4 - OPERATIONAL PROCEDURES | | |
| 4.1 | Procedures | 11 |
| 4.2 | Maintenance of Dam | 11 |
| 4.3 | Maintenance of Operating Facilities | 11 |
| 4.4 | Description of Any Warning System in Effect | 11 |
| 4.5 | Evaluation | 11 |
| SECTION 5 - HYDRAULIC/HYDROLOGIC | | |
| 5.1 | Evaluation of Features | 12 |
| SECTION 6 - STRUCTURAL STABILITY | | |
| 6.1 | Evaluation of Structural Stability | 13 |
| SECTION 7 - ASSESSMENT/REMEDIAL MEASURES | | |
| 7.1 | Dam Assessment | 14 |
| 7.2 | Further Investigations | 15 |
| 7.3 | Remedial Measures | 15 |

APPENDICES

Sheet

APPENDIX A

| | |
|--------------------------------------|---|
| Vicinity Map | 1 |
| Site Plan | 2 |
| Plan and Profile of Dam | 3 |
| Plan and Profile of Primary Spillway | 4 |
| Primary Spillway Inlet Details | 5 |
| Primary Spillway Outlet Details | 6 |
| Lake Drain Details | 7 |
| Typical Sections | 8 |

APPENDIX B

| | |
|--------------------------------------|----------|
| Boring Location Plan | 1 |
| Profile of Subsurface Materials | 2 |
| Geologic Reports | 3, 4 & 5 |
| Hydrologic and Hydraulic Design Data | 6 and 7 |

APPENDIX C

| | |
|----------------------------|----------|
| Overtopping Analysis - PMF | 1 thru 6 |
|----------------------------|----------|

APPENDIX D

| | |
|----------------------------------------|----------|
| Photographs of Dam, Lake and Watershed | 1 thru 5 |
|----------------------------------------|----------|

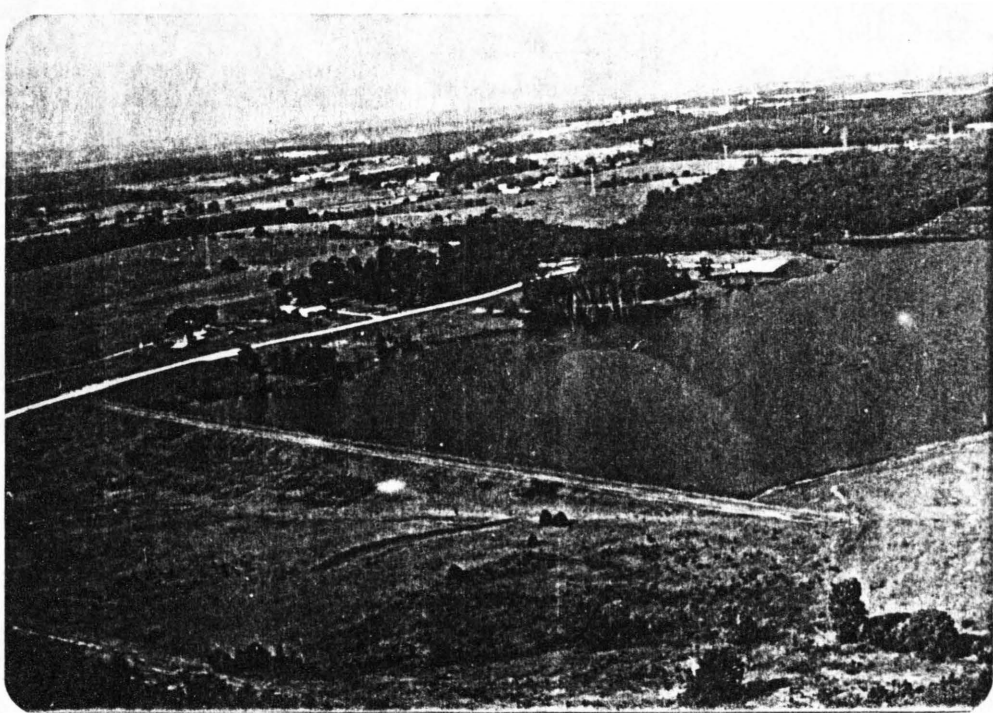
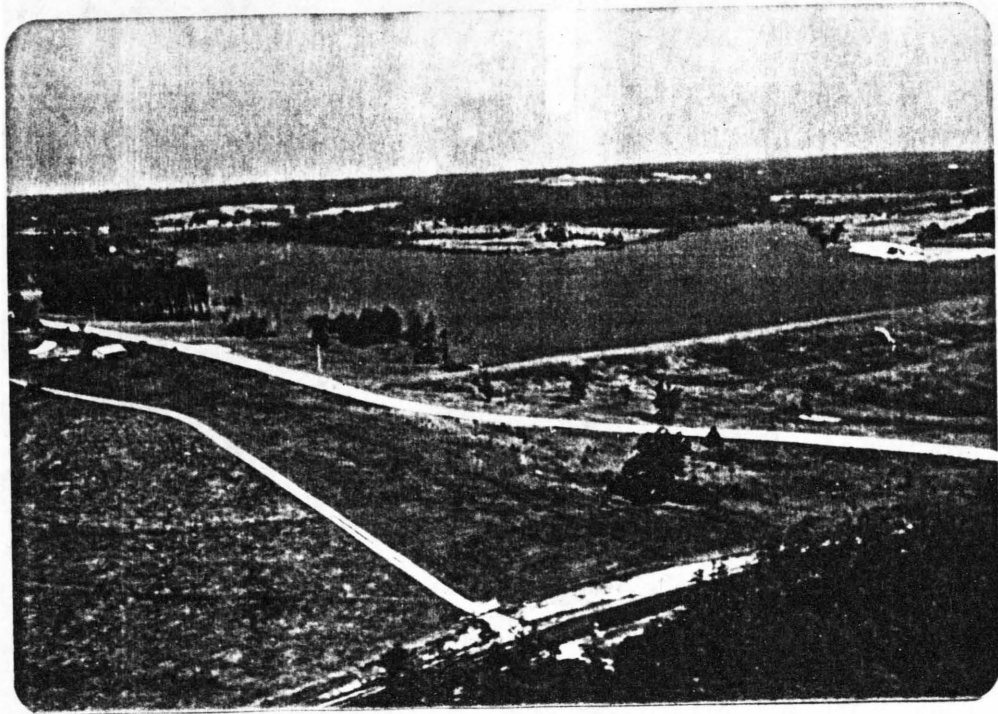

Aerial Views of Lake and Dam

SECTION 1 - PROJECT INFORMATION

1.1 GENERAL:

A. Authority:

The National Dam Inspection Act, Public Law 92-367, authorized the Secretary of the Army, through the Corps of Engineers, to initiate a program of safety inspection of dams throughout the United States. Pursuant to the above, the St. Louis District, Corps of Engineers, District Engineer directed that a safety inspection be made of Little Prairie Dam in Phelps County, Missouri.

B. Purpose of Inspection:

The purpose of the inspection was to make an assessment of the general condition of the dam with respect to safety, based upon available data and a visual inspection in order to determine if the dam poses hazards to human life or property.

C. Evaluation Criteria:

Criteria used to evaluate the dam were furnished by the Department of the Army, Office of the Chief of Engineers, "Recommended Guidelines For Safety Inspection of Dams." These guidelines were developed with the help of several federal agencies and many state agencies, professional engineering organizations, and private engineers.

1.2 DESCRIPTION OF PROJECT:

A. Description of Dam and Appurtenances:

Little Prairie Dam is an earth fill structure approximately 46 ft high and 1450 ft long at the crest. The appurtenant works consist of a concrete drop inlet and asbestos cement pipe primary spillway, which is located near the south end of the dam, and a grass covered emergency spillway, which is located at the north abutment. The inlet structure contains two slide gates for partial drawdown of the lake. A 12 in. diameter cast-iron pipe can be used to drain the entire reservoir. Sheet 3 of Appendix A shows a plan of the embankment and spillways and a profile of the embankment.

B. Location:

The dam is located in the northeast part of Phelps County, Missouri on a small tributary of the Bourbeuse River. The dam and lake are within the Dillon, Missouri

quadrangle sheet, 3 miles west of St. James (SE 1/4 Section, Twp. 38 N, R 7 W-latitude 37° 59.7'; longitude 91° 41.4'). Sheet 1 of Appendix A shows the general vicinity and location of the dam. Sheet 2 shows a plan of the immediate area of the dam and lake.

C. Size Classification:

With an embankment height of 46 ft and a maximum storage capacity of approximately 2226 acre-ft, the dam is in the intermediate size category.

D. Hazard Classification:

The St. Louis District, Corps of Engineers has classified this dam as a high hazard dam. Their estimate of the potential damage zone extends 5 miles downstream of the dam. Within the first mile of the damage zone are two houses, one mobile home and three improved road bridges.

E. Ownership:

The dam was designed by and is owned by the Missouri Department of Conservation. Their address is 2901 North Ten Mile Drive, Jefferson City, Missouri 65101.

F. Purpose of Dam:

The purpose of the dam is to provide recreation, although some flood prevention is also provided.

G. Design and Construction History:

The dam was designed by the Missouri Department of Conservation and was completed in 1965. Plans for construction are available and have been used to prepare this report. No significant problems in regards to seepage through or stability of the embankment are known to have occurred since the dam was built. According to Missouri Department of Conservation personnel, no modifications have been made to the dam.

H. Normal Operating Procedure:

Normal flows will be passed by an uncontrolled drop inlet spillway, whereas a grassed emergency spillway would come into operation for major floods. The concession stand operator at the site indicated that the emergency spillway has not been in service.

1.3 PERTINENT DATA :

Pertinent data about the dam, appurtenant works, and reservoir are presented in the following paragraphs. Sheet 3 of Appendix A is a plan of the embankment and spillways with a profile of the dam. Sheet 4 presents a plan and profile of the primary spillway. Sheets 5 and 6 present details of the primary inlet and outlet structures. Presented on Sheet 7 are details of the lake drain. Typical sections of the facilities are shown on Sheet 8.

A. Drainage Area:

The drainage area for this dam, as obtained from the Dillon, Missouri 7 1/2' quadrangle sheet and the Plans for Construction, is equal to approximately 1540 acres.

B. Elevations (Feet Above M.S.L.):

- (1) Top of dam (measured): North end 1039.8; center 1039.5; south end 1040.6.
Top of Dam (Plans for Construction): 1039.0.
- (2) Principal Spillway Crest: Plans for Construction 1032.0; (assumed as 1032.0 for all other measurements).
- (3) Emergency Spillway Crest: Plans for Construction 1036.0; measured 1036.4.
- (4) Primary Spillway Outlet Pipe Invert: Plans for Construction 995.0; measured 995.0.
- (5) Maximum Design Pool: 1039.0.
- (6) Pool on Date of Inspection: Measured 1031.6.
- (7) Apparent High Water Mark Of Record: reported 1036±.
- (8) Streambed at Centerline of Dam: Plans for Construction 993.
- (9) Maximum Tailwater: Unknown.

C. Discharge at Dam Site:

- (1) All normal discharge at the dam site is through uncontrolled spillways.
- (2) Estimated Discharge Capacity at Top of Dam (El. 1039.5): 3149 cfs.

D. Reservoir Surface Areas:

- (1) At Principal Spillway Crest: Plans for Construction 100 acres.
- (2) At Top of Dam: Plans for Construction 139.5 acres.

E. Storage Capacities :

- (1) At Principal Spillway Crest (El. 1032): Plans for Construction 1301.1 acre-ft.
- (2) At Top of Dam (El. 1039.5): 2226 acre-ft.

F. Reservoir Lengths:

- (1) At Principal Spillway Crest (Estimated from Plans for Construction): 4400 ft.
- (2) At Top of Dam (Estimated from Plans for Construction): 4800 ft.

G. Dam:

- (1) Type: Rolled earth.
- (2) Length at Crest: 1450 ft.
- (3) Height: 46 ft.
- (4) Top Width: 16 ft.
- (5) Side Slopes: 3H: 1V. (Lower portion of downstream face is 5H:1V.).
- (6) Zoning: Homogeneous silts and clays.
- (7) Cutoff: Shallow core trench.

H. Principal Spillway:

- (1) Location: South end of dam--Station 4+50.
- (2) Type: 9 ft by 9 ft concrete riser (35 ft crest length) with a 30 in. diameter asbestos cement pipe through dam.

I. Emergency Spillway:

- (1) Location: North abutment.
- (2) Type: Grass-covered earth with 200 ft crest length and 4 H: 1 V side slopes.

SECTION 2 - ENGINEERING DATA

2.1 GENERAL:

Available design computations and reports for Little Prairie Dam include site geology reports prepared by the Missouri Geological Survey (Sheets 3 thru 5, Appendix B). In addition, the Plans for Construction contain test boring records and some hydrologic data. The design notes for Little Prairie Dam are not available from the Missouri Department of Conservation at this time. However, the MDC has provided additional hydrologic and hydraulic information (Sheets 6 and 7, Appendix B). No documentations of construction inspection records have been obtained. There are no documented maintenance and operation data to our knowledge.

2.2 DESIGN:

A. Surveys:

The locations and elevations of two temporary benchmarks are shown on Sheet 2 of Appendix A. Neither of these two temporary benchmarks was located during the visual inspection. The crest of the primary spillway was used as a benchmark and was assumed to the same elevation as indicated on the plans for construction (1032.0).

B. Geology and Subsurface Materials:

Physiographically, the site is located in the Salem Plateau Uplands, which is characterized by rolling to hilly topography. The subsurface materials generally consist of 2 to 5 ft of loess underlain by residual soils and bedrock. Geological maps of the area indicate that the bedrock is the Jefferson City formation of the Canadian Series of the Lower Ordovician system. The Jefferson City formation consists of medium to massive beds of dolomite. The bedrock is relatively tight as a result of the lack of development of solution enlarged joints or an irregular bedrock surface due to weathering.

A boring plan and classification of the soils encountered in the borings (Sheets 25 and 26 of the Plans for Construction) are presented as Sheets 1 and 2 of Appendix B. Sheet 3 thru 5 of Appendix B presents a brief description of the geology of the lake area (prepared by the Missouri Geological Survey). The soils encountered in the borings are generally clayey silts and low to medium plasticity clays with some high plasticity clays overlying bedrock. Most of the borings were carried to bedrock, with depths to bedrock ranging from 5 to 25 ft. The maximum penetration of the borings was to approximately elevation 990.

C. Foundation and Embankment Design:

No foundation or embankment design reports were available from the Missouri Department of Conservation. Sheet 3 of Appendix A (from Plans for Construction) shows a plan view of a foundation trench drain. A typical section of this trench drain is shown on Sheet 8 of Appendix A. This foundation drainage system is shown located from about Station 7+00 to Station 11+50 at a distance of 60 ft downstream of the centerline of the dam. The bottom elevation of the trench drain ranges from 997 at Station 11+50 to 995 at its point of exit (Station 7+50). A shallow core trench apparently was constructed at the base of the dam from Station 4+00 to Station 17+00.

Borrow material for the dam was obtained from the concession area and emergency spillway northwest of the dam. Stability analyses and compaction specifications have not been obtained. There is apparently no particular zoning of the embankment, and no internal drainage features (except for the previously described foundation drainage system) are known to exist. No construction inspection test results have been obtained.

D. Hydrology and Hydraulics:

Some basic hydrologic and hydraulic design data have been provided by the Missouri Department of Conservation and are presented on Sheets 6 and 7 of Appendix B. The Plans for Construction also contain some hydrologic design data. These data are contained on Sheets 2 and 7 of Appendix A. Based on these data, a field check of spillway dimensions and embankment elevations, and a check of the drainage area on U.S.G.S. quad sheets, a hydrologic analysis using U.S. Army Corps of Engineers guidelines was performed and appears in Appendix C, Sheets 1 to 6. It was concluded that the primary and emergency spillways combined will pass 39 percent of the Probable Maximum Flood.

E. Structure:

Structural design computations for appurtenant structures were not obtained. Details of all concrete structural elements (riser structure, etc.) are shown on the Plans for Construction and are presented on Sheets 4 through 7 of Appendix A.

F. Construction:

No construction inspection data have been obtained.

2.3 OPERATION:

No operation and maintenance information was available. Inspection indicates that maintenance of the dam (mowing the grass and brush removal) is done periodically.

2.4 EVALUATION:

No design computations or construction records were available for this dam. Thus, the engineering data available were inadequate to make a detailed assessment of the design, construction, and operation.

Seepage and stability analyses comparable to the requirements of the "Recommended Guidelines for Safety Inspection of Dams" were not available, which is considered a deficiency. These seepage and stability analyses should be performed for appropriate loading conditions (including earthquake loads) and made a matter of record.

SECTION 3 - VISUAL INSPECTION

3.1 GENERAL:

The field inspection was made on 24 August 1978. The inspection team consisted of personnel from Anderson Engineering, Inc. of Springfield, Missouri and Hanson Engineers, Inc. of Springfield, Illinois. The team members were:

Roger Phillips - Anderson Engineering (Instrument Man)
Steve Brady - Anderson Engineering (Civil Engineer)
Jack Healy - Hanson Engineers (Geotechnical and Structural Engineer)
Gene Wertepny - Hanson Engineers (Hydraulic Engineer)

3.2 DAM:

The dam is an earth fill embankment constructed from borrow obtained from the emergency spillway area and the concession area northwest of the dam. Based on the soil borings, the fill material would be expected to consist of low to medium plasticity clays, clayey silts and some high plasticity clays.

The embankment is grass-covered and appears in good condition. No sloughing of the embankment or seepage through or under the embankment was evident. No animal burrows were noted. There appears to be an area of slight seepage on the south abutment near the primary spillway discharge. The grass was green, and the ground slightly damp in this area.

The foundation drain outlet on the north side of the lake drain was dry. The foundation drain on the south side of the lake drain was slightly damp. There was some slight erosion at the downstream embankment-abutment contacts (more pronounced on the south abutment).

The horizontal alignment appeared as shown on the plans. No surface cracking or unusual movement was obvious. It should be noted, however, that the elevations along the top of the dam which were obtained in the field were approximately 0.5 ft to 0.8 ft higher than as indicated on the Plans for Construction (see Section 1.3.B of this report). All other elevations obtained in the field agreed fairly well with those indicated on the Plans for Construction.

No instrumentation (monuments, piezometers, etc.) was observed.

A. Primary Spillway and Outlet:

The riser structure was in good condition--no cracking or spalling of concrete was noted. The intake structure outside the chain link fence was surrounded on three sides by some brush. The two slide gates which are used for partial drawdown appeared to be in good condition on the dry side (the wet side could not be inspected). The lower slide gate (elevation 1024) appeared to have a small leak under the bottom.

The outlet pipe was also in good condition. There was a very small flow dripping from the primary spillway outlet pipe, possibly coming from the leaking slide gate. Joint leakage could also contribute to the noted outlet flow.

The plunge pool is lined with riprap, but some erosion and sloughing around the plunge pool was noticed. The outlet channel was in good condition. Some small trees and brush are present in the channel a few hundred feet beyond the plunge pool.

B. Emergency Spillway:

The emergency spillway is in good condition; it measures 200 ft in width with 4H:1V side slopes. The base and side slopes of the emergency spillway are grass-covered. No erosion was noted, and it appears that the emergency spillway has never been used.

3.3 RESERVOIR AND WATERSHED:

The immediate periphery of the lake was grass- and timber covered with moderate slopes. No sloughing or serious erosion of reservoir banks was noted.

The concession stand operator indicated that the high pool was just below the crest of the emergency spillway (1973).

3.4 EVALUATION:

Small tree and brush growths noted in the discharge channel of the primary spillway should be removed, and all future growth should be removed on a yearly basis. Additional riprap could be placed around the plunge pool for protection during high discharge. Brush should be cleared around the primary spillway crest. Excessive growth in this area could cause entrance restrictions. Visually observed erosional areas are deficiencies which, if left uncontrolled or uncorrected, could lead to serious problems in the future. These deficiencies should be able to be corrected by normally scheduled routine maintenance.

Because the valve of the lake drain is located on the downstream side of the dam, the full head of water impounded by the dam is acting entirely through the dam. The area around the lake drain outlet should be periodically inspected for seepage which might indicate a leak or rupture of the drain pipe and could eventually initiate a piping failure through the embankment.

Photographs of the dam, appurtenant structures, and the reservoir and watershed are presented in Appendix D.

SECTION 4 - OPERATIONAL PROCEDURES

4.1 PROCEDURES:

Although there are controlled outlet works for this dam, no regulating procedures are known to exist. The pool is normally controlled by rainfall, runoff, evaporation and the capacities of the uncontrolled spillways. It is not known whether the drawdown facilities have ever been used.

4.2 MAINTENANCE OF DAM:

No maintenance information was available. Some maintenance of the dam is apparently done yearly. The crest of the dam and 15 to 20 ft down each slope were mowed within a couple of weeks prior to our site visit (see Sheet 1 of Appendix D).

4.3 MAINTENANCE OF OPERATING FACILITIES:

Although the drawdown facilities appear to be in good condition, it is not known whether they are regularly maintained.

4.4 DESCRIPTION OF ANY WARNING SYSTEM IN EFFECT:

The inspection team is unaware of any existing warning system for this dam.

4.5 EVALUATION:

Tree and brush growth should be removed from the dam on a yearly basis. Although not serious now, erosional areas at abutment-dam contact will need some repair in the future. The use of riprap to prevent future erosion in these areas is a possibility. Riprap should be maintained around the plunge pool area. The area of apparent seepage on the south abutment near the primary spillway discharge may be the result of leakage around the primary spillway conduit. This area should be checked periodically to insure that seepage does not increase. Any increase in seepage should be brought to the attention of the owner's engineer.

SECTION 5 - HYDRAULIC/HYDROLOGIC

5.1 EVALUATION OF FEATURES:

A. Design and Experience Data:

Design data used by the Missouri Department of Conservation to design this dam are presented as Sheets 6 and 7 of Appendix B of this report. Some hydrologic data as shown in the Plans for Construction are presented on Sheets 2 and 7 of Appendix A. Based on this information, a field check of spillway dimensions and embankment elevations, and a check of the pool and drainage areas from the U.S.G.S. quad sheet (Dillon, Missouri quad sheet), a hydrologic analysis was performed using U.S. Army Corps of Engineers guidelines and appears in Appendix C, Sheets 1 to 6.

B. Visual Observations:

The riser structure and outlet pipe for the primary spillway appear in good condition. A small flow from the outlet pipe (lake level below spillway crest) indicates the possibility of some small leakage through the lower slide gate or frame separated joints. The earth- and grass-covered emergency spillway is in good condition. The emergency spillway has apparently never been used.

Facilities available to draw down the pool appear to be in good condition. The primary spillway is located near the south end of the dam, and the emergency spillway is located on the north abutment. Spillway releases would not be expected to endanger the integrity of the dam.

C. Overtopping Potential:

Based on the hydrologic and hydraulic analysis as presented in Appendix C, the combined primary and emergency spillways will pass 39 percent of the Probable Maximum Flood. The Probable Maximum Flood is defined as the flood discharge that may be expected from the most severe combination of critical meteorologic and hydrologic conditions that are reasonably possible in the region. The recommended guidelines from the Department of the Army, Office of the Chief of Engineers, require that this structure (intermediate size with high downstream hazard potential) pass 100 percent of the PMF, without overtopping. The structure will pass a 100-year frequency flood without overtopping.

The Probable Maximum Flood will overtop the dam by 1.78 ft for a duration of 4.25 hours with a maximum outflow of 17,277 c.f.s. Discharge over the combined primary and emergency spillways at top of dam (El. 1039.5 ft) is 3149 c.f.s.

SECTION 6 - STRUCTURAL STABILITY

6.1 EVALUATION OF STRUCTURAL STABILITY:

A. Visual Observations:

No serious deficiencies which would affect the structural stability of this dam were noted during the field inspection. However, if left unchecked, the erosion at abutment-dam contact areas could cause some localized stability problems in the future. Possible joint leakage in the primary spillway outlet pipe should be periodically checked and investigated if it increases.

B. Design and Construction Data:

No design and construction data were obtained. Seepage and stability analyses comparable to the requirements of the "Recommended Guidelines for Safety Inspection of Dams" were not available, which is considered a deficiency.

C. Operating Records:

No operating records of the drawdown facilities are available.

D. Post-Construction Changes:

To our knowledge, no post-construction changes have been made.

E. Seismic Stability:

The structure is located in seismic zone 1, which is historically the least active zone in terms of occurrence and magnitude of earthquakes. The seismic loading prescribed for zone 1 is generally not critical for a well-constructed earth dam of this size.

SECTION 7 - ASSESSMENT/REMEDIAL MEASURES

7.1 DAM ASSESSMENT:

A. General:

This Phase I inspection and evaluation should not be considered as being comprehensive since the scope of work contracted for is far less detailed than would be required for an in-depth evaluation of dams. Latent deficiencies, which might be detected by a totally comprehensive investigation, could exist.

B. Safety:

The embankment itself is generally in good condition. The minor items which have been noted previously--such as tree growth, riprap protection and erosion--can and should be corrected and controlled. Seepage and stability analyses comparable to the requirements of the "Recommended Guidelines for Safety Inspection of Dams" were not available, which is considered a deficiency.

The dam will be overtopped by flows in excess of 39 percent of the Probable Maximum Flood. Overtopping of an earthen embankment could cause serious erosion and could possibly lead to failure of the structure.

C. Adequacy of Information:

The conclusions in this report were based on review of the Plans for Construction, the brief geologic report prepared by the Missouri Geologic Survey, the performance history as related by others, and visual observation of external conditions. The inspection team considers that these data are sufficient to support the conclusions herein.

D. Urgency:

The remedial measures recommended in paragraph 7.3 should be accomplished in the near future. If the minor deficiencies listed in paragraph B are not corrected and if good maintenance is not provided, the embankment condition will continue to deteriorate and possibly could become serious in the future.

E. Necessity for Phase II:

Based on the result of the Phase I inspection, no Phase II inspection is recommended.

F. Seismic Stability:

The structure is located in seismic zone 1, which is historically the least active zone in terms of occurrence and magnitude of earthquakes. The seismic loading prescribed for zone 1 is generally not critical for a well-constructed earth dam of this size.

7.2 FURTHER INVESTIGATIONS:

A very small amount of water was exiting from the outlet pipe on the day of the inspection. The source of the water could be a leaking slide gate at the intake structure. However, there exists the possibility of some joint leakage in the outlet pipe. Although apparently not serious at this time, this condition should be monitored periodically in the future to detect any changes (increased flow or piping).

The possible slight seepage area near the south abutment of the dam should be periodically inspected. Increases in the flow would suggest incipient piping along the primary spillway which might lead to a piping failure.

7.3 REMEDIAL MEASURES:

The following remedial measures and maintenance procedures are recommended and should be supervised by an engineer experienced in the design and construction of dams.

- (1) The spillway should be redesigned and/or the height of the dam should be increased to pass the PMF.
- (2) Remove the existing tree and brush growth in the discharge channel of the primary spillway, and remove all future tree and brush growth on a yearly basis. Cut the brush around the primary spillway to prevent restrictions.
- (3) Correct the minor erosion activity at the embankment-abutment contacts on the downstream side of the dam.
- (4) Check the downstream slope periodically for seepage and stability problems, especially in the south abutment seepage area and around the lake drain pipe. If slides, seeps or other evidence of distress are observed, immediate inspection by a qualified engineer is required, and frequent follow-up inspections will be necessary.
- (5) A detailed inspection of the dam should be made at least every 5 years by an engineer experienced in the design and construction of dams. More frequent inspections may be required if slides, seeps, or other items of distress are observed.

- (6) Seepage and stability analyses should be performed by an engineer experienced in the design and construction of dams and made a matter of record.

APPENDIX A

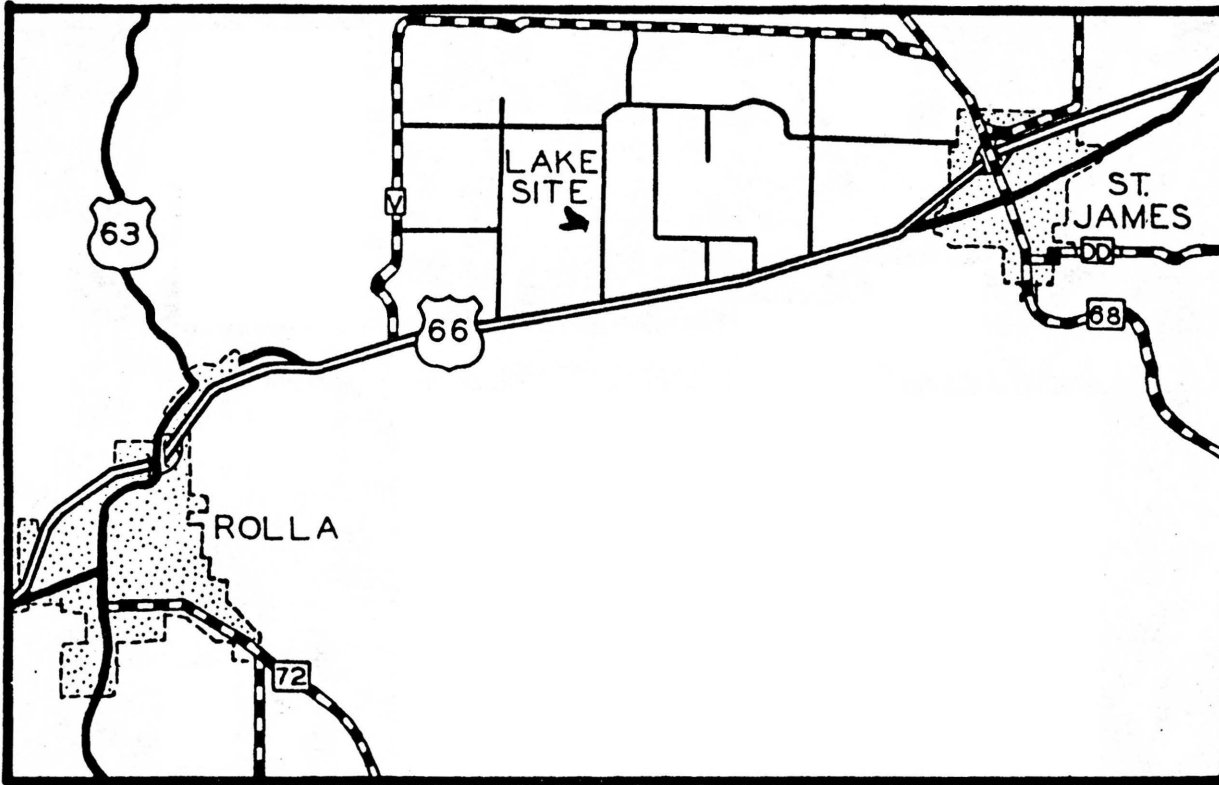

VICINITY MAP

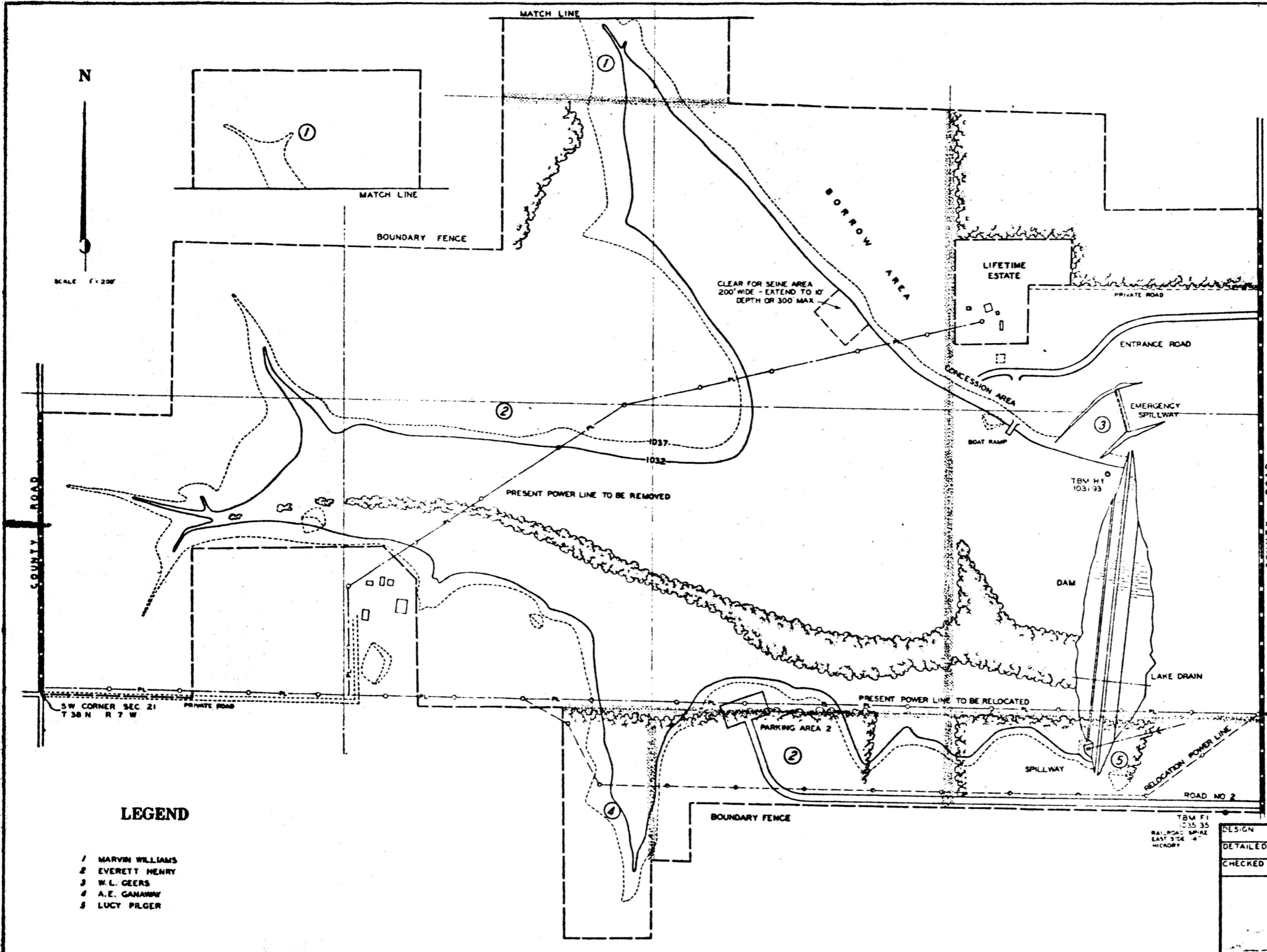

LAKE DATA

| | |
|-----------------|---------|
| DRAINAGE AREA | 1540 AC |
| LAKE AREA | 100 AC |
| RATIO | 15 TO 1 |
| COMMISSION LAND | 314 AC |

LEGEND

- 1 MARVIN WILLIAMS
- 2 EVERETT HENRY
- 3 W.L. GEERS
- 4 A.E. GANAWAY
- 5 LUCY PILGER

Sheet 2 Appendix A

| | | |
|--------------------------------------------|--------|----------------------------------|
| DESIGN | W.F.E. | MISSOURI CONSERVATION COMMISSION |
| DETAILED | W.F.E. | |
| CHECKED | R.M.H. | |
| | | PHELPS CO. LAKE |
| | | GENERAL PLAN |
| APPROVED | | SHEET 1 OF 20 |
| W.F.E. CHIEF OF FISHERIES | | DATE OCT 1984 |
| R.M.H. DIRECTOR MISSOURI COMMISSION | | JOB NO. 83-18 |

TIE POINTS

TRAVERSE POINT C2 = 3+00 & DAM
 TRAVERSE POINT C23 = 9+35.6 & DAM
 TRAVERSE POINT C22 = 18+05.7 & DAM

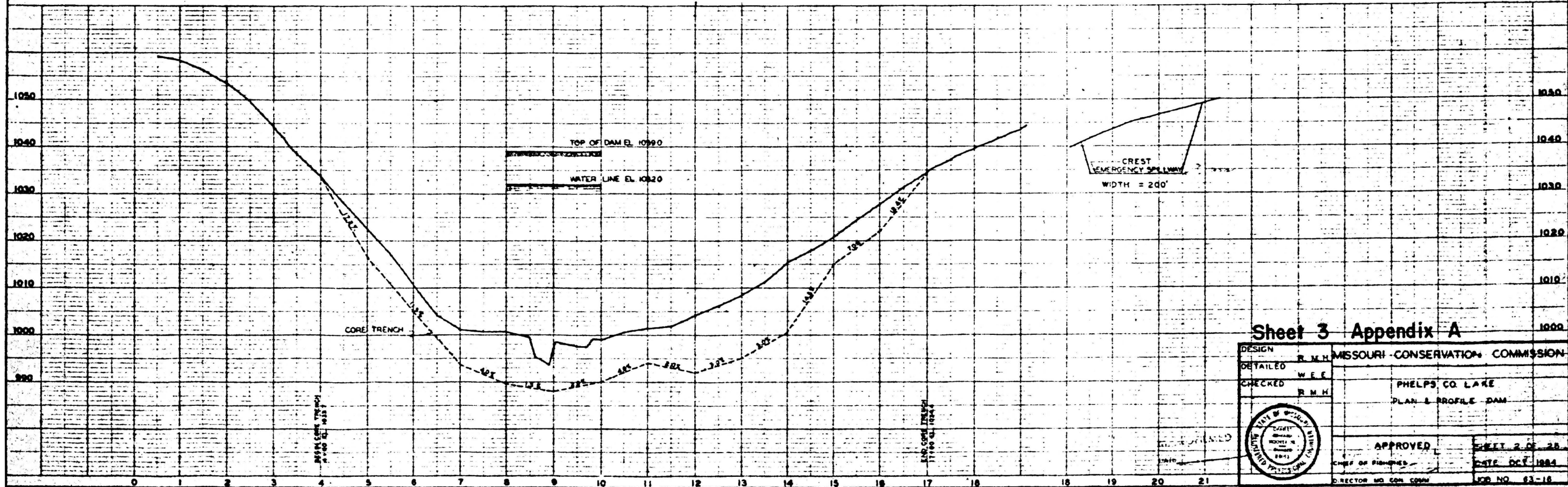
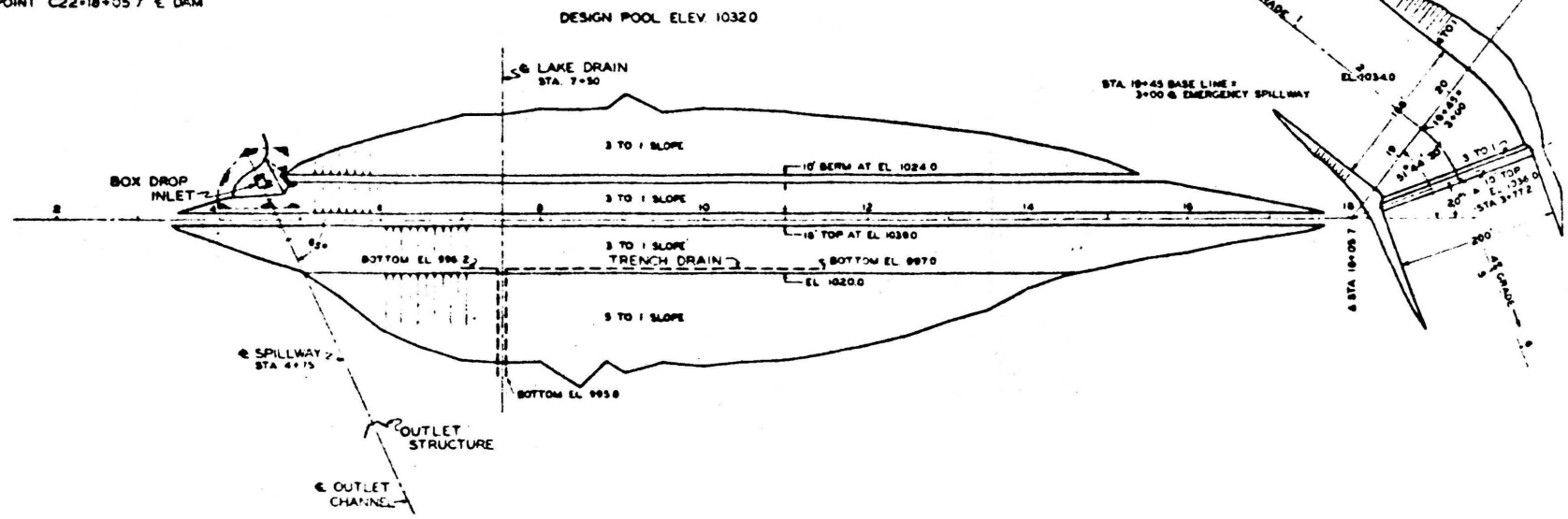

Sheet 3 Appendix A

| | | |
|----------|----------|-------------------------------------------------|
| DESIGN | R. M. H. | MISSOURI CONSERVATION COMMISSION |
| DETAILED | W. E. E. | |
| CHECKED | R. M. H. | PHELPS CO. LAKE PLAN & PROFILE DAM |
| APPROVED | | SHEET 2 OF 28 DATE OCT 1984 JOB NO. 83-16 |

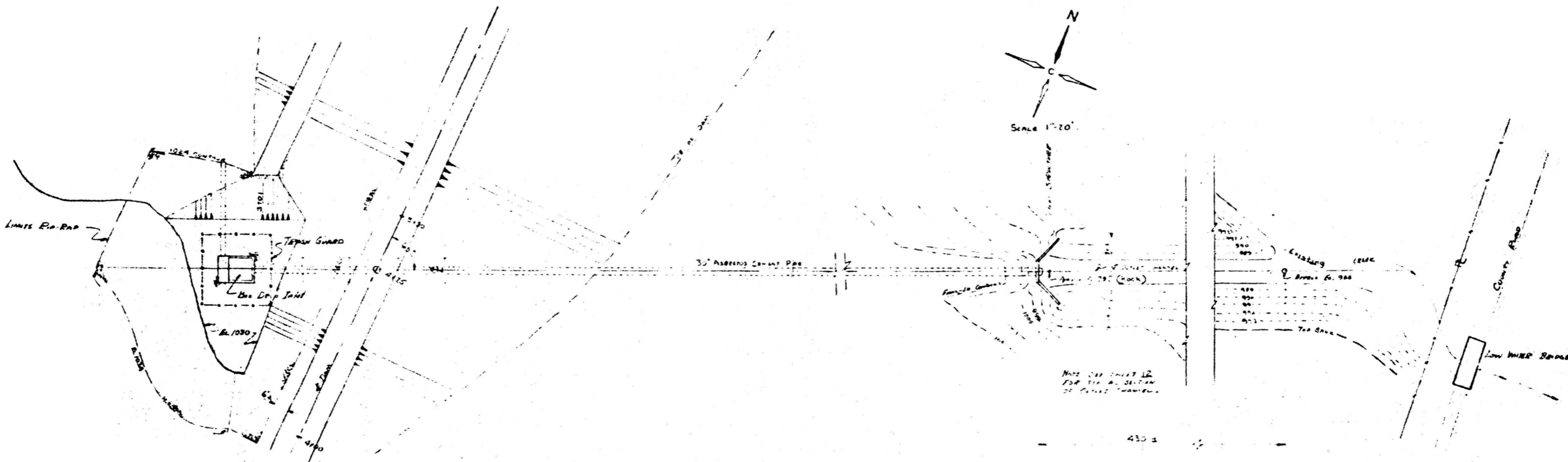

PLAN

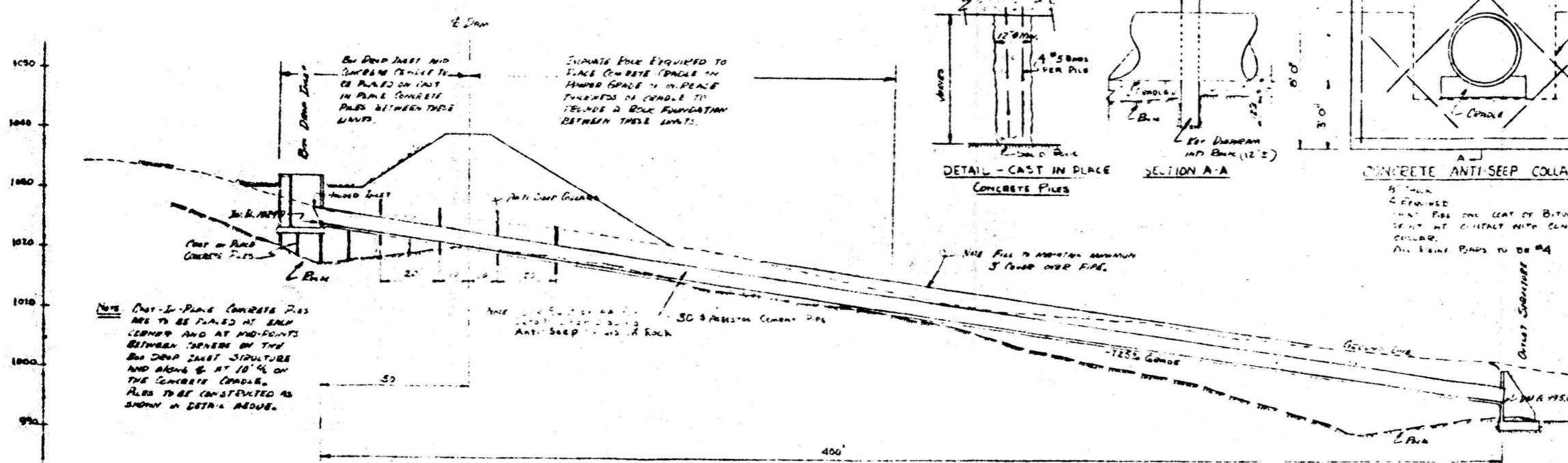

PROFILE

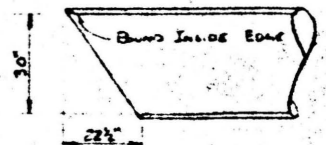
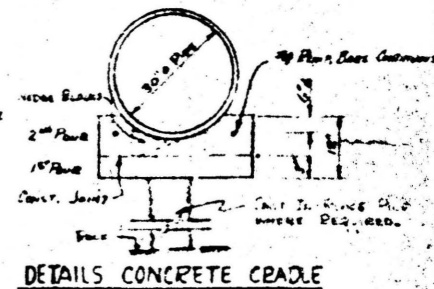
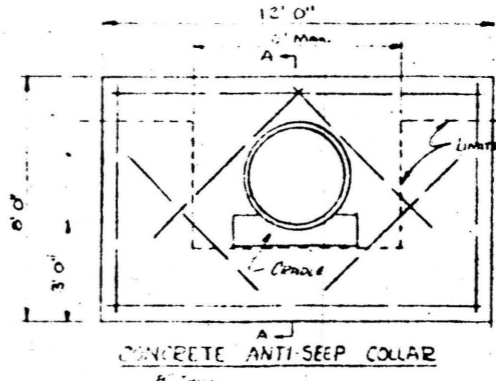
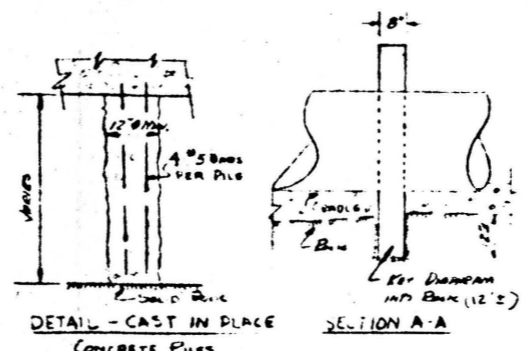

NOTE: CAST-IN-PLACE CONCRETE PILES ARE TO BE PLACED AT EACH CORNER AND AT MID-POINTS BETWEEN CORNERS OF THE BOX DRAIN INLET STRUCTURE AND ALONG & AT 10' ON THE CONCRETE CRADLE. ALSO TO BE CONSTRUCTED AS SHOWN IN DETAIL ABOVE.

NOTE: 30' ASBESTOS CEMENT PIPE TO BE PLACED ON TOP OF ANTI-SEEP GUARD & ROCK.

NOTE: FILL TO MAINTAIN MINIMUM 3' COVER OVER PIPE.

CONCRETE ANTI-SEEP COLLAR
 5' THICK
 5' REQUIRED
 1" BITUMINOUS SEAL AT CONTACT WITH CONCRETE COLLAR.
 ALL REIN. BARS TO BE #4

FABRICATION FOR HOODED INLET

Sheet 4 Appendix A

| | | |
|-------------------------|--------|----------------------------------|
| DESIGN | R.M.H. | MISSOURI CONSERVATION COMMISSION |
| DETAILED | R.M.H. | |
| CHECKED | C.E.H. | |
| | | PHELPS CO. LAKE |
| | | PLAN & PROFILE - SPILLWAY |
| APPROVED | | SHEET 3 OF 29 |
| DIRECTOR MO. CON. COMM. | | DATE OCT. 1894 |
| | | JOB NO. 83-18 |

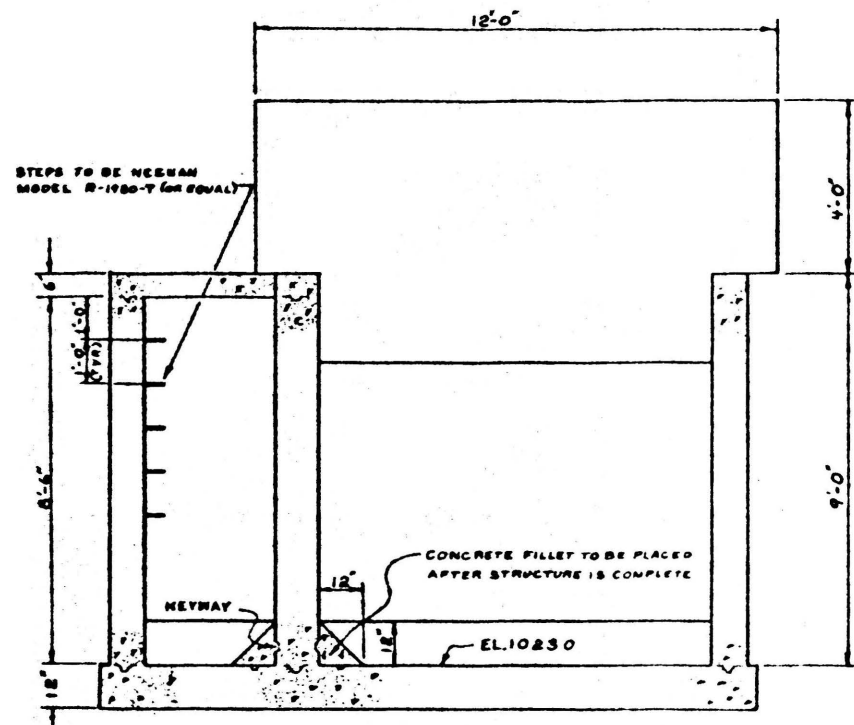

SECTION A A

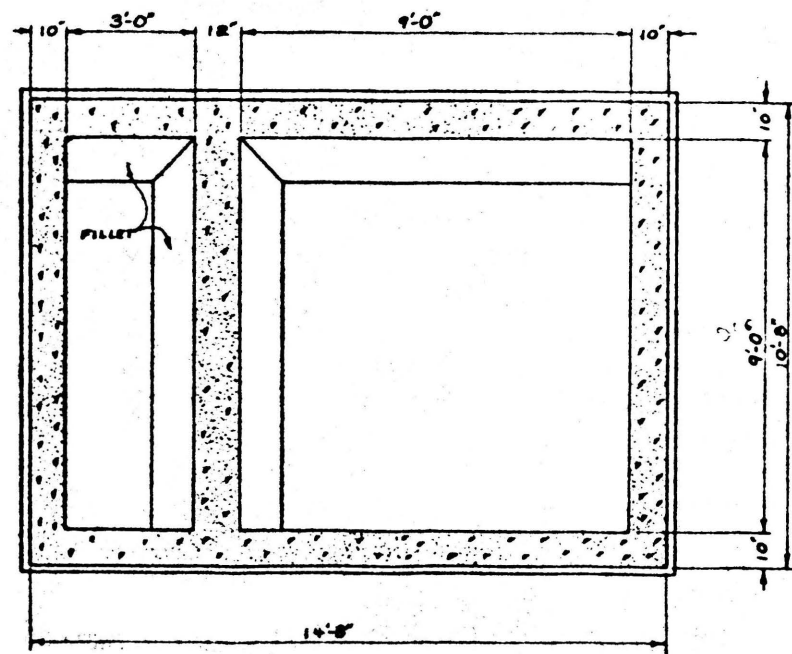

PLAN FOOTING

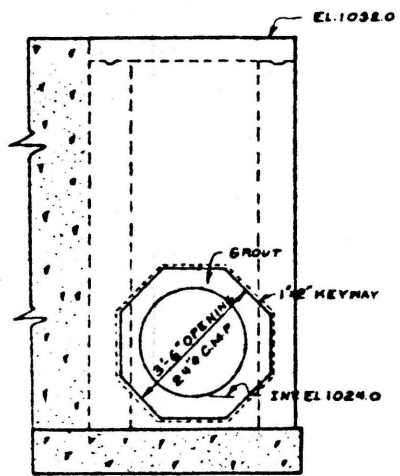

SECTION B-B

NOTE: MANHOLE COVER + RIM TO BE NEEHAN MODEL NO R-666-HOR EQUAL WITH A TYPE 'A' (TOP HASP) LOCKING DEVICE

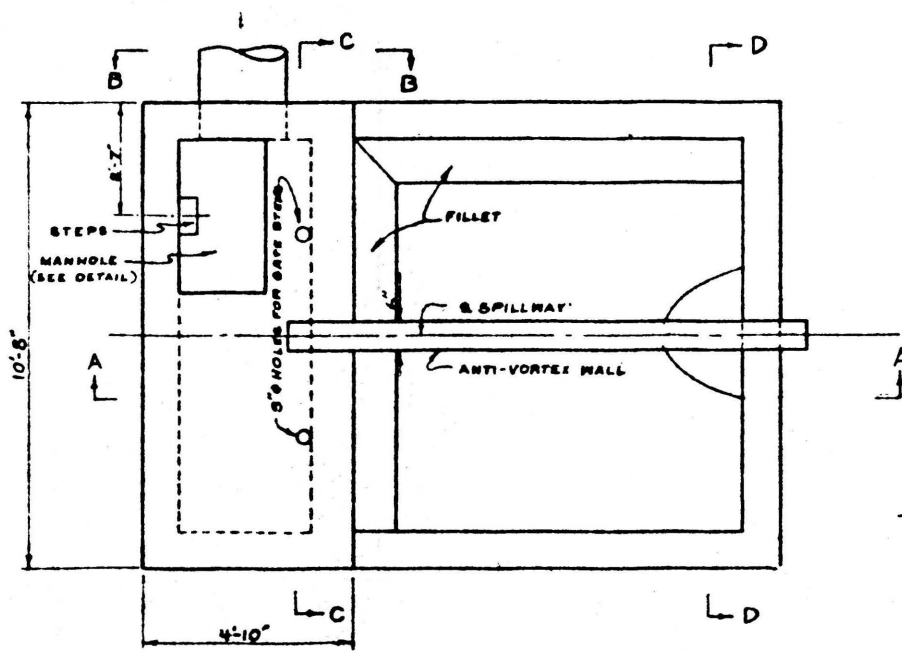

PLAN TOP

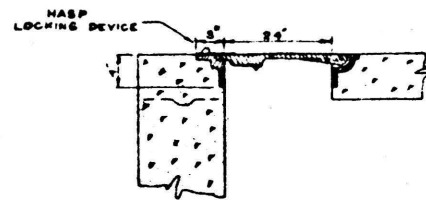

DETAIL
MANHOLE + COVER

NOTE: PAINT PIPE WITH ASPHALT, AND USE FINE IRON WIRE TO HOLD LEAD SHEET IN PLACE DURING GROUTING.

NOTE: GROUT SHALL BE OF NON-SHRINK TYPE, EMBECA OR APPROVED EQUAL, USE PREMIXED MORTAR, ADDING PEA GRAVEL, BY WEIGHT, TO RECOMMENDED MIX 'B'.

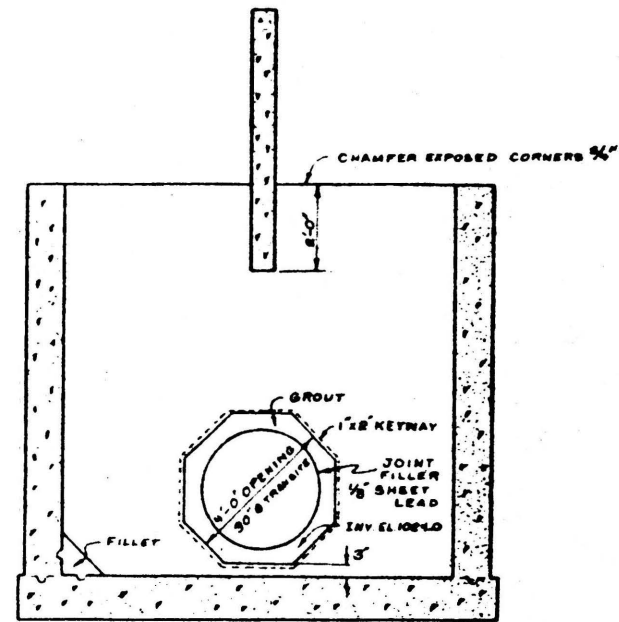

SECTION D-D

NOTE: PIPE AND GRADLE TO BE POURED AS A UNIT AND SEPARATED FROM THE DROP INLET STRUCTURE BY A JOINT OF PREMOULDED ASPHALTIC EXPANSION JOINT FILLER

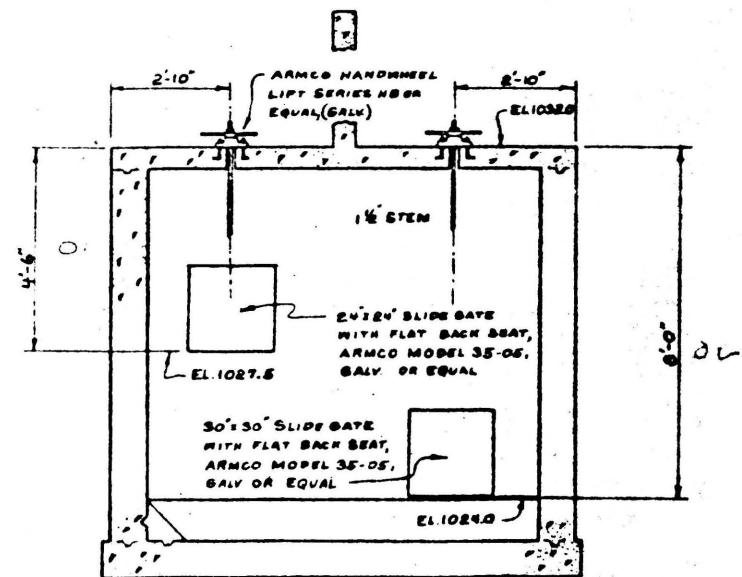

SECTION C-C

Sheet 5 Appendix A

QUANTITIES

| | |
|---------------------|------------|
| CONCRETE | 242 CUYD |
| STEEL | 2,4480 LBS |
| 30" x 30" GATE | 1.00 |
| 24" x 30" GATE | 1.00 |
| HANDWHEEL LIFTS | 2.00 |
| MANHOLE COVER + RIM | 1.00 |
| CAST IRON STEPS | 5.00 |

| | | |
|----------|--------------------|---------------------------------------------|
| DESIGN | D. L. H. | MISSOURI CONSERVATION COMMISSION |
| DETAILED | D. L. H. | |
| CHECKED | C. E. H. | PHELPS CO. LAKE |
| | | SPILLWAY BOX DROP INLET STRUCTURE - DETAILS |
| APPROVED | <i>[Signature]</i> | SHEET 4 OF 21 |
| | | DATE OCT. 1984 |
| | | JOB NO. 83-16 |

NOTE: GROUT SHALL BE NON-SHRINK TYPE, EMSECA OR EQUAL. USE PREMIXED MORTAR, ADDING PEA GRAVEL BY WEIGHT TO RECOMMENDED MIX 'B'

NOTE: PAINT PIPE WITH ASPHALT AND USE FINE IRON WIRE TO HOLD LEAD SHEET IN PLACE DURING GROUTING

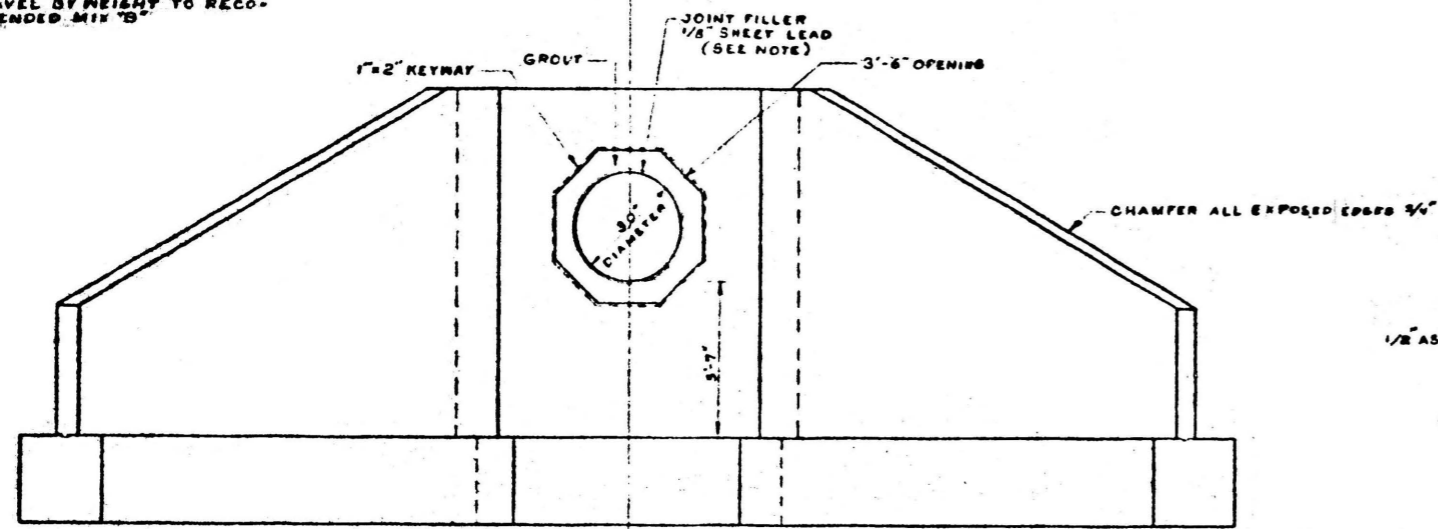

ELEVATION

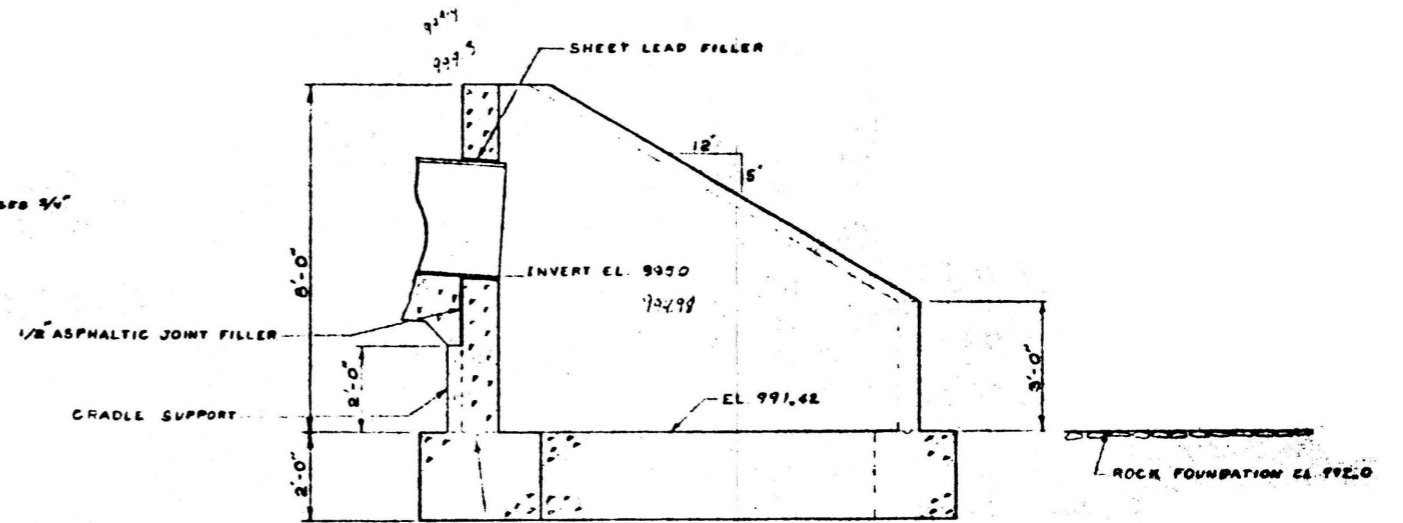

NOTE: PIPE AND CRADLE TO BE POURED AS A UNIT. PIPE TO BE SEPARATED FROM THE STRUCTURE BY 1/8" OF SHEET LEAD, AND THE CRADLE BY 1/2" OF ASPHALTIC EXPANSION JOINT FILLER

SECTION A-A

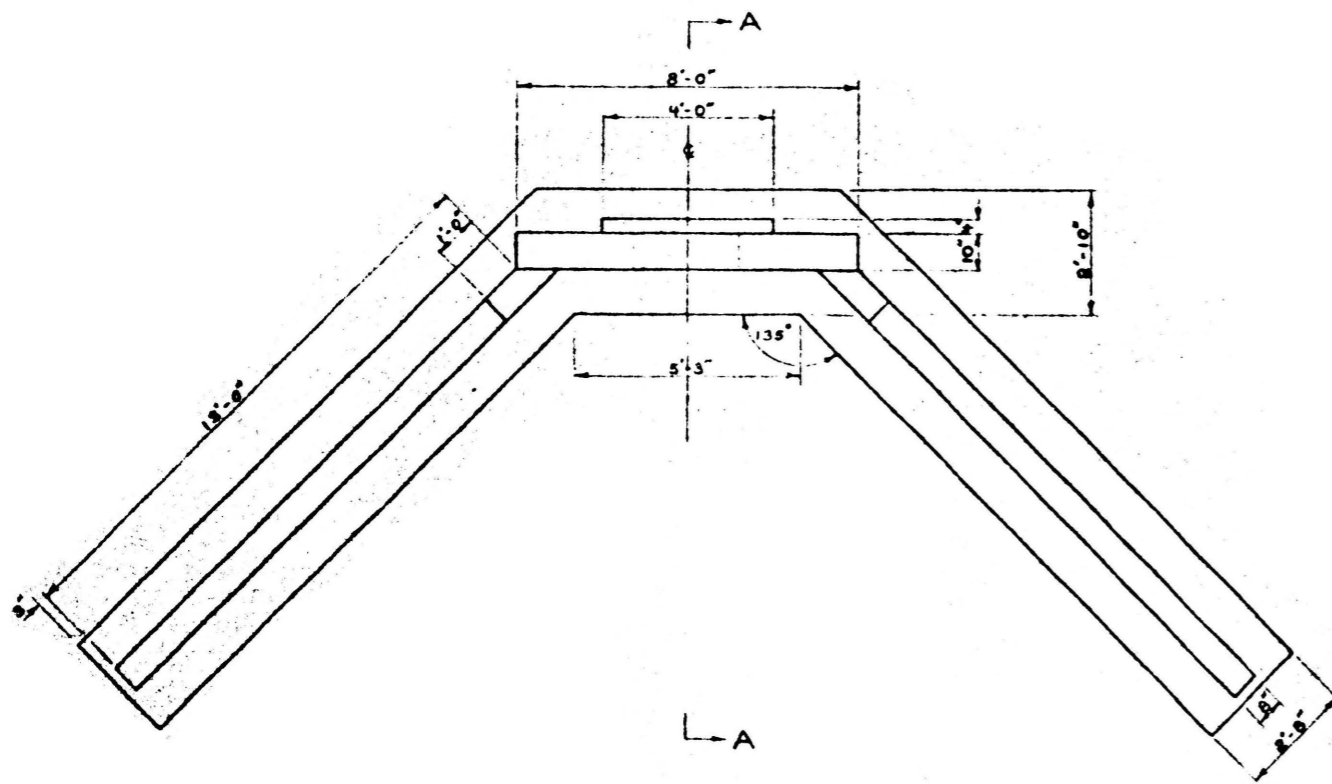

PLAN

QUANTITIES
OUTLET STRUCTURE

| | |
|----------|-----------------------|
| CONCRETE | 12.6 YDS ³ |
| STEEL | 372.3 LBS |

Sheet 6 Appendix A

| | | |
|----------|----------|-------------------------------------|
| DESIGN | D. L. H. | MISSOURI CONSERVATION COMMISSION |
| DETAILED | D. L. H. | |
| CHECKED | R. M. H. | PHELPS CO. LAKE |
| | | SPILLWAY OUTLET STRUCTURE - DETAILS |
| | | APPROVED |
| | | <i>Charles B. ...</i> |
| | | CHIEF OF FISHERIES |
| | | DIRECTOR MO. CON. COM. |
| | | SHEET 6 OF 28 |
| | | DATE OCT 1944 |
| | | JOB NO. 22-18 |

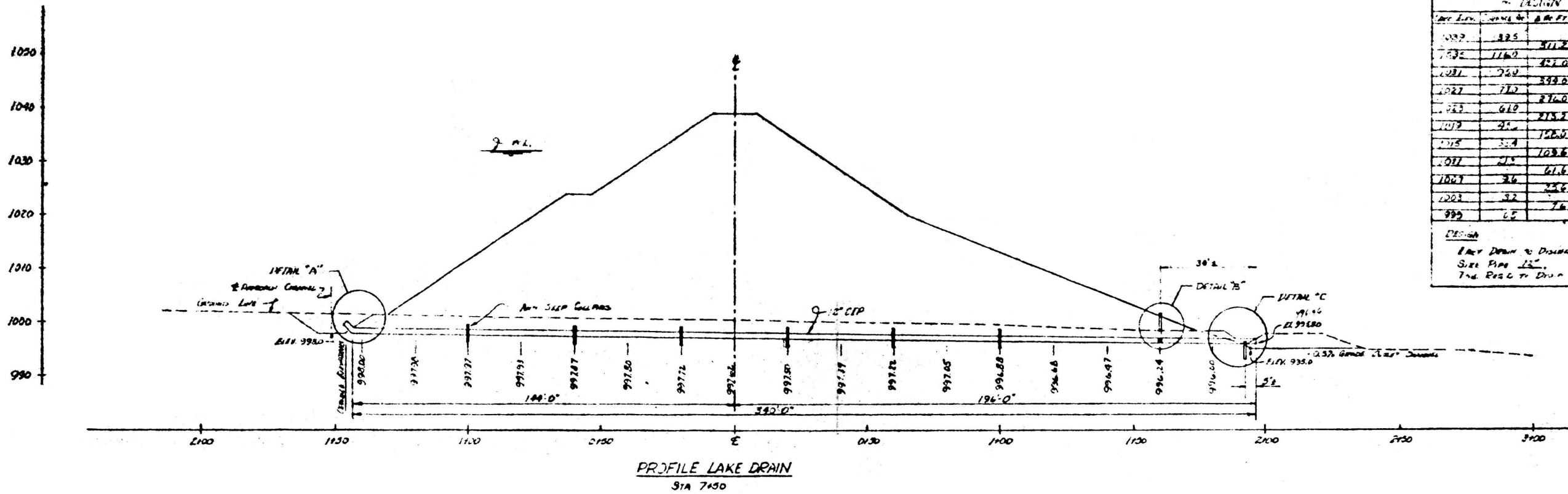

| Sta. No. | Elev. at P.C. | Elev. at P.T. | Notes |
|----------|---------------|---------------|-------------------------|
| 1082 | 1125 | 1112 | |
| 1083 | 1160 | 1147.2 | |
| 1084 | 740 | 727.6 | Design No. 10840 |
| 1085 | 740 | 727.6 | P.C. = 1.9011 |
| 1087 | 710 | 691.6 | |
| 1088 | 610 | 575.0 | EL. 1088 - 1089 = 1.499 |
| 1089 | 95 | 94.4 | |
| 1095 | 304 | 299.4 | |
| 1097 | 215 | 208.6 | |
| 1098 | 96 | 94.8 | |
| 1099 | 96 | 93.2 | |
| 1203 | 32 | 26 | |
| 999 | 65 | 76 | |

DESIGN
 1. Lay Down to Discharge 485 Ac. Ft. in 6.0 Days.
 Size Pipe 12".
 The P.C. to Drain Line 2.27% Grade.

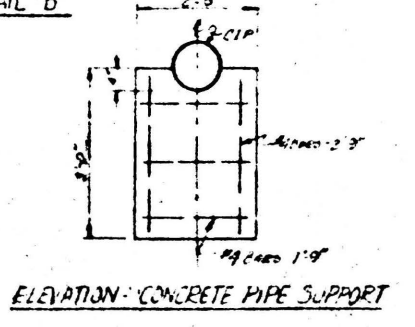
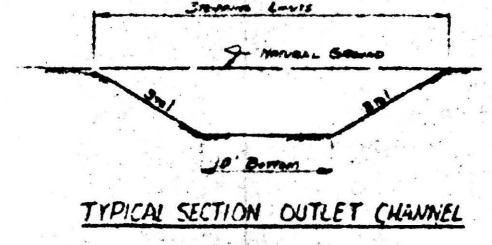
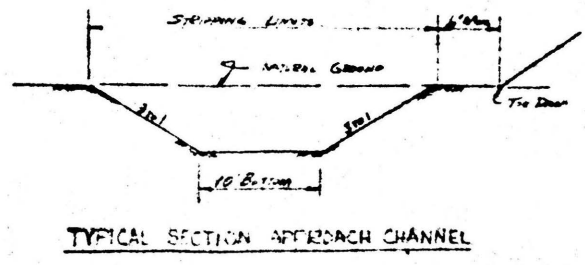
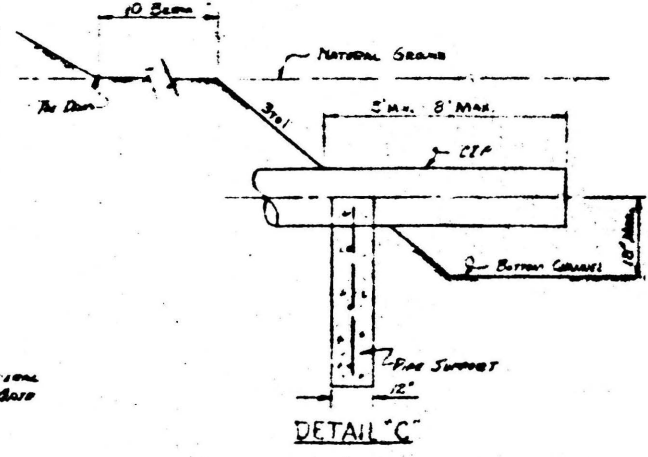
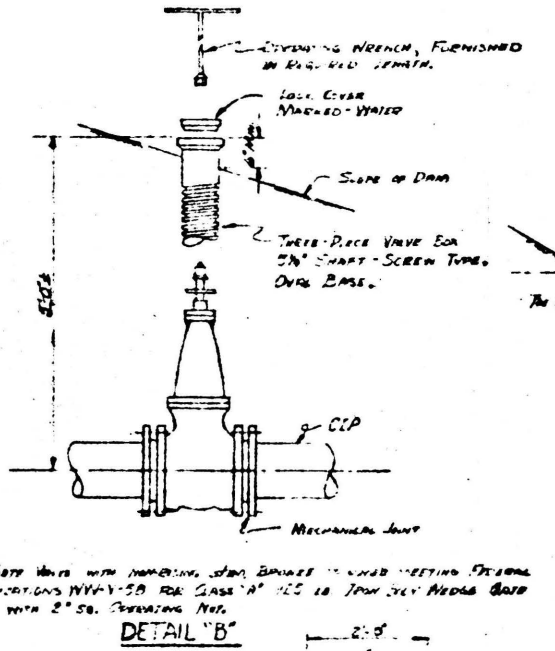
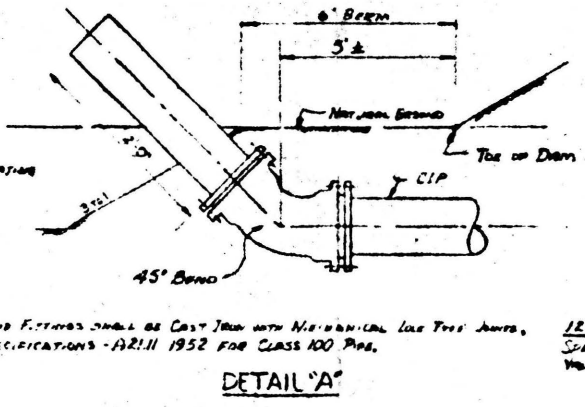
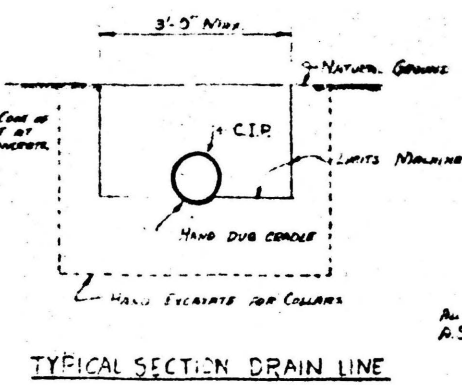
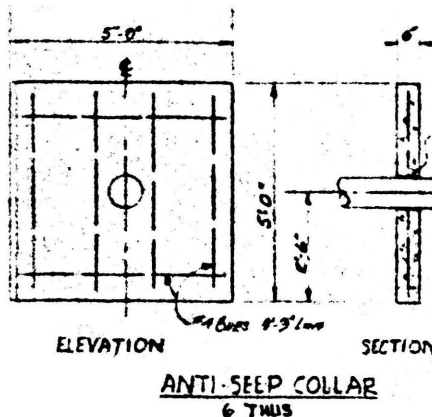

All Pipe and Fittings shall be Cast Iron with Mechanical Line Type Joints, R.S.A. Specifications - April 1952 for Class 100 Pipe.

12" Gate Valve with Handwheel, Stem Bronze, used meeting Federal Specifications W44-58 for Class 'A' 125 lb. Iron Gate Valve Body Valve, with 2" St. Operating Nut.

Sheet 7 Appendix A

| | | |
|-------------|----------|----------------------------------|
| DESIGN | R. M. H. | MISSOURI CONSERVATION COMMISSION |
| DETAILED | R. M. H. | PHELPS CO. LAKE LAKE DRAIN |
| CHECKED | D. L. H. | |
| MICROFILMED | | APPROVED: |
| DATE | | DATE |

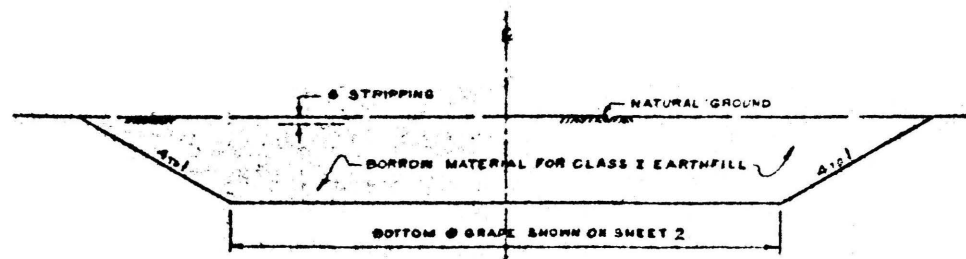

TYPICAL SECTION-EMERGENCY SPILLWAY

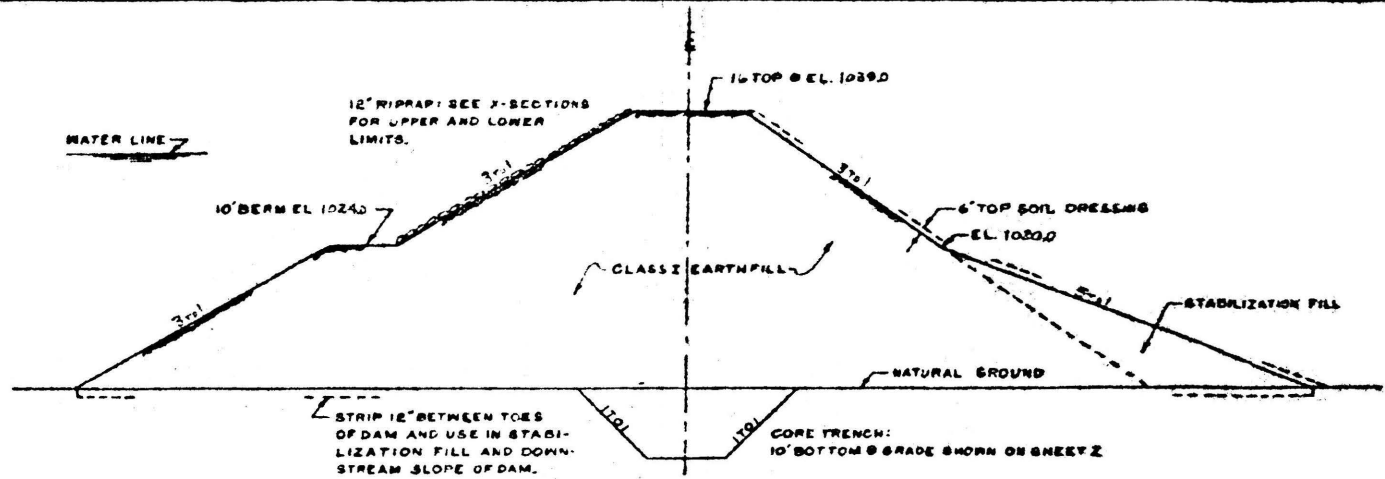

TYPICAL SECTION-DAM

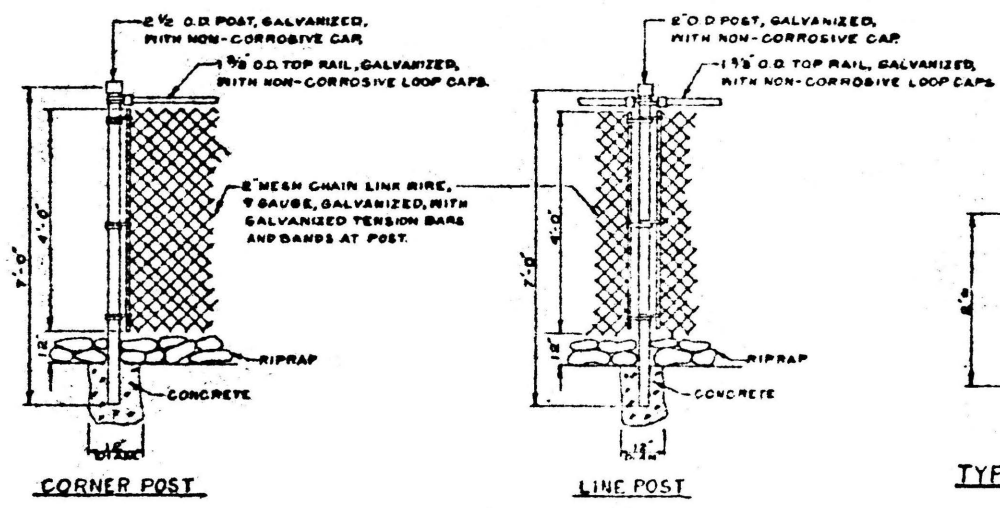

DETAILS-TRASH BARRIER

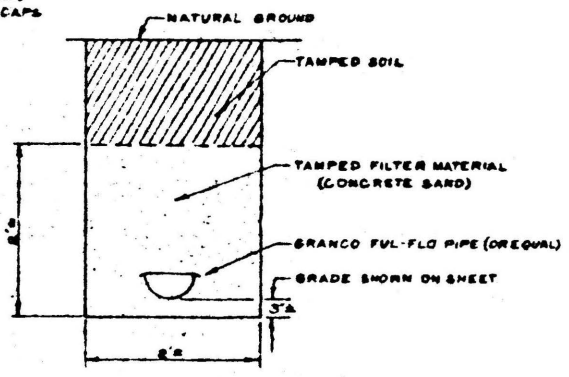

TYPICAL SECTION-TRENCH DRAIN

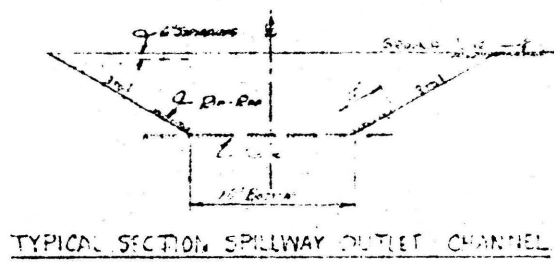

TYPICAL SECTION SPILLWAY OUTLET CHANNEL

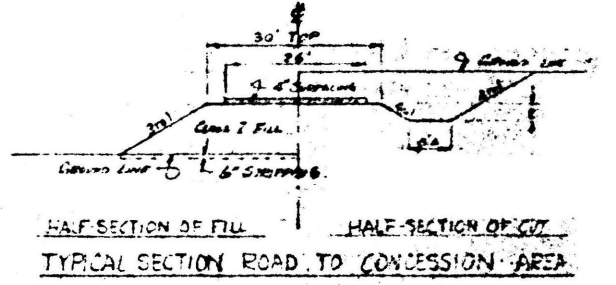

TYPICAL SECTION ROAD TO CONCESSION AREA

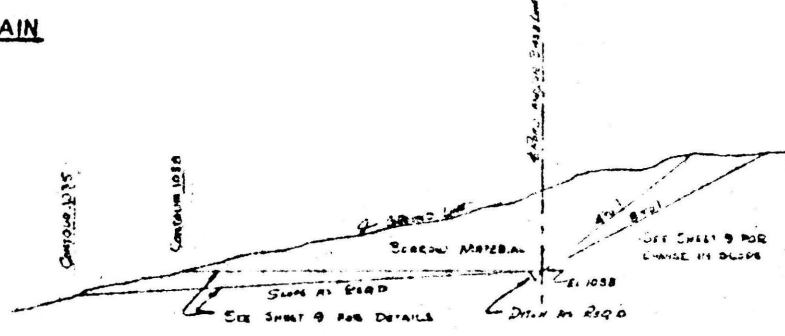

TYPICAL SECTION BORROW AREA

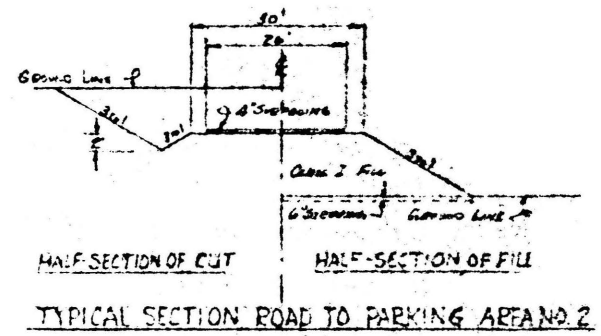

TYPICAL SECTION ROAD TO PARKING AREA 2

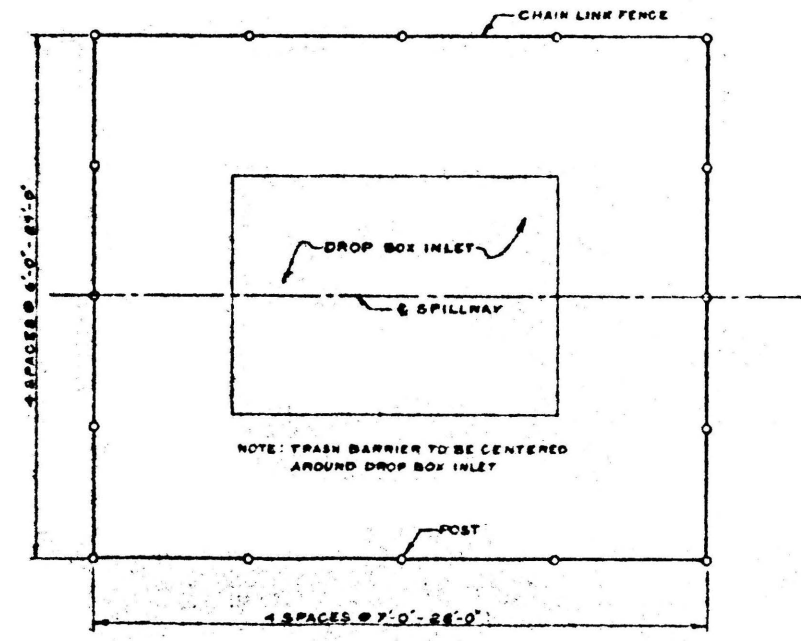

PLAN-TRASH BARRIER

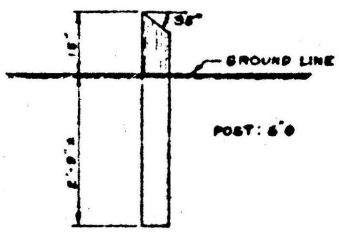

TYPICAL SECTION-GUARD POST

Sheet 8 Appendix A

| | | |
|-------------|----------|--------------------------------------------------|
| DESIGN | R. L. H. | MISSOURI CONSERVATION COMMISSION |
| DETAILED | R. L. H. | |
| CHECKED | R. M. H. | PHELPS CO. LAKE |
| | | TRASH BARRIER TYPICAL SECTIONS AND SPECIAL NOTES |
| MICROFILMED | | APPROVED |
| DATE | | DATE OCT. 1984 |
| | | DR. NO. 83-18 |

APPENDIX B

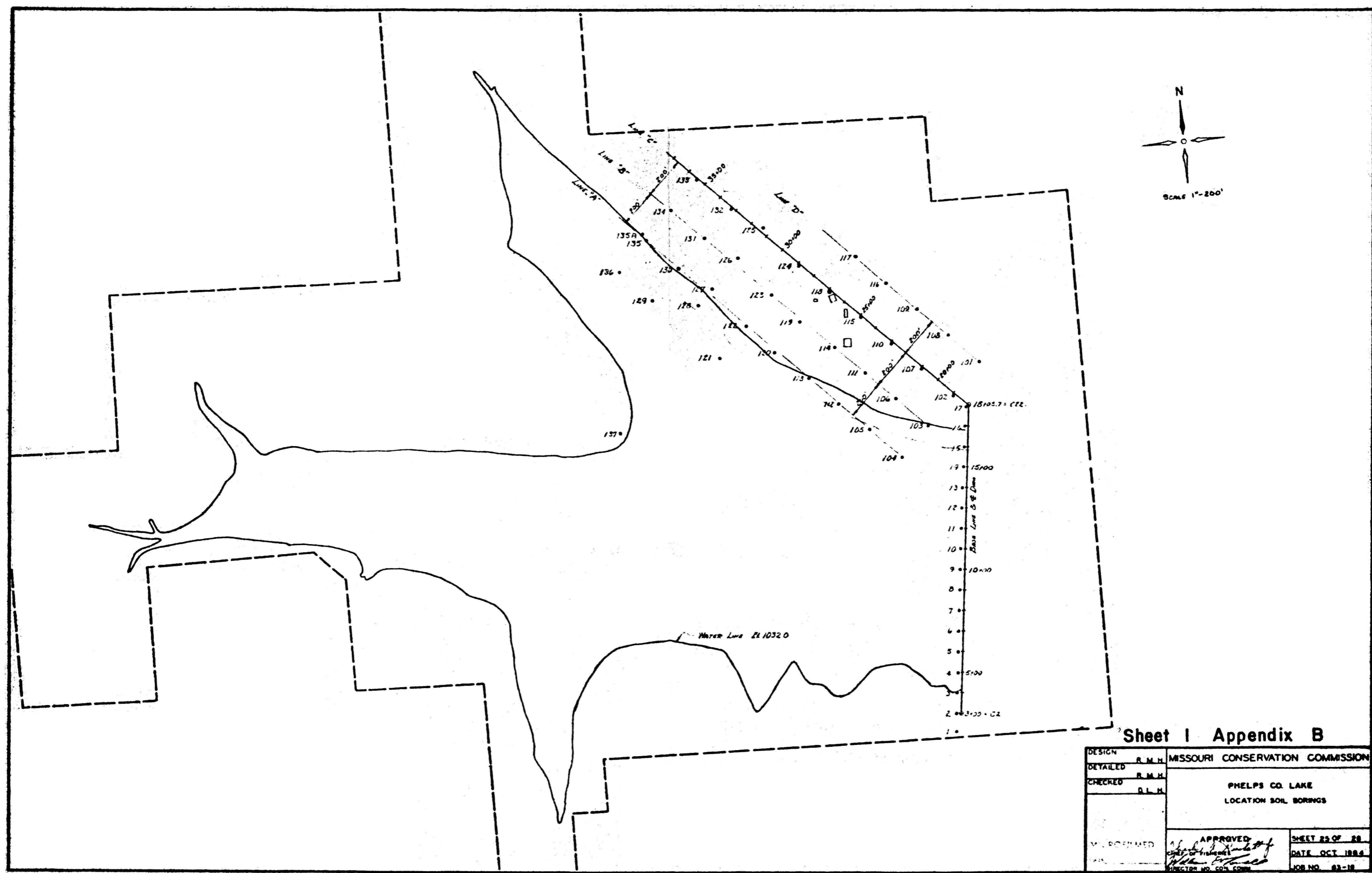

Sheet I Appendix B

| | | |
|----------|------------------------|------------------------------------------|
| DESIGN | R. M. H. | MISSOURI CONSERVATION COMMISSION |
| DETAILED | R. M. H. | |
| CHECKED | R. L. H. | |
| | | PHELPS CO. LAKE LOCATION SOIL BORINGS |
| APPROVED | <i>[Signature]</i> | SHEET 25 OF 28 |
| | DIRECTOR MO. CON. COM. | DATE OCT 1984 |
| | | JOB NO. 83-18 |

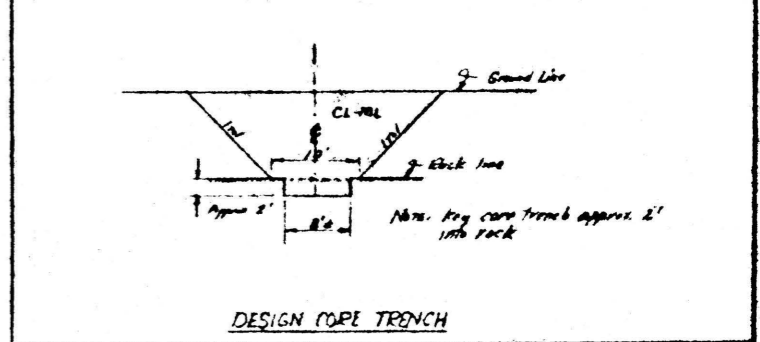
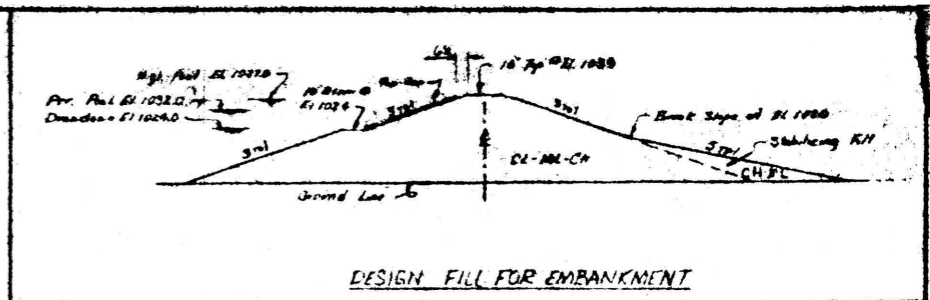
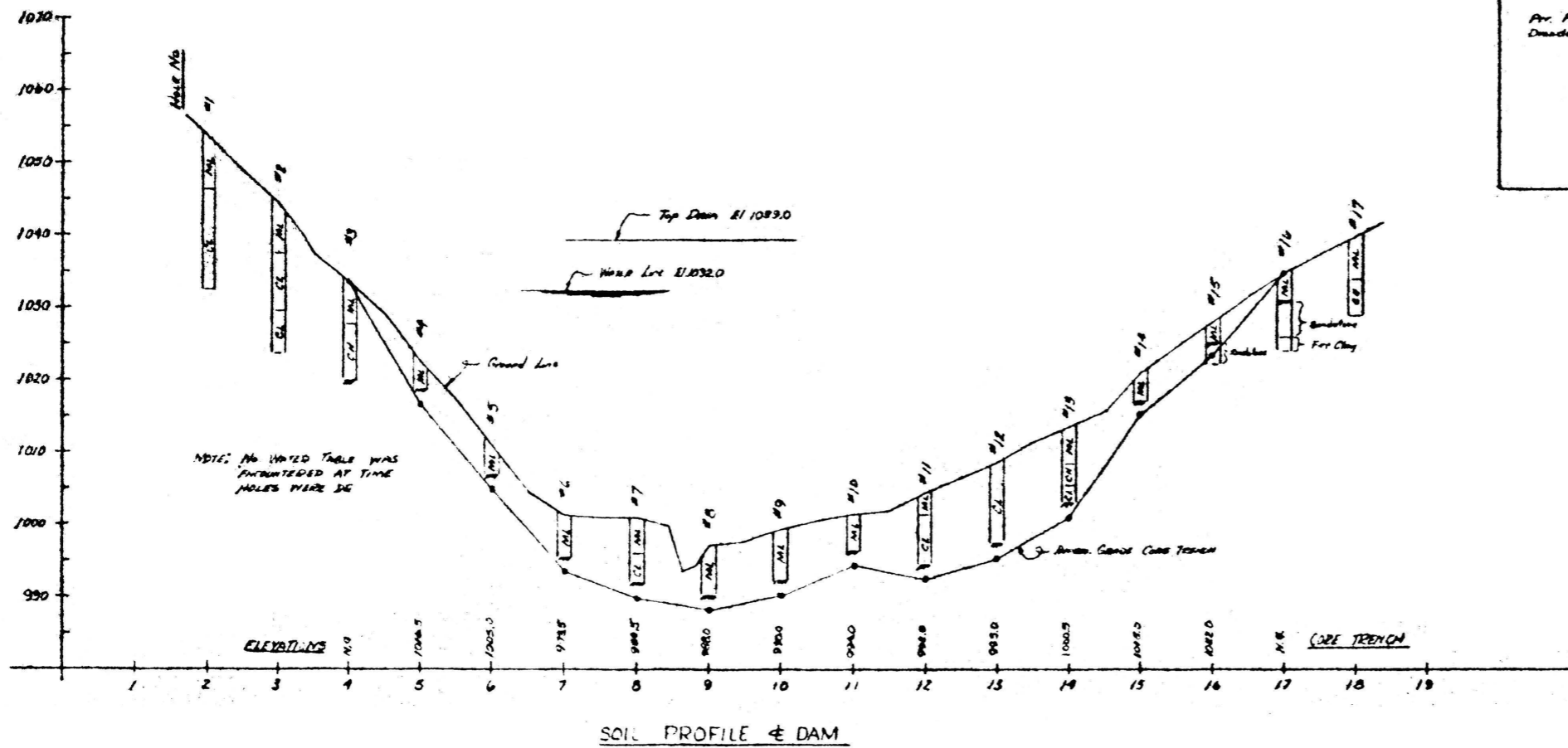

NOMECLATURE

HOLES NO 1 THRU NO 100 - EMBANKMENT
 HOLES NO 101 THRU NO 200 - BORROW
 HOLES NO 201 AND ABOVE - AS SPECIFIED

ROCK IS SHOWN AS --- WITH TYPE SPECIFIED.

PENETRATION TEST & WATER TABLE 4-BLOW PER FOOT

UNIFIED SOIL CLASSIFICATION

| GROUP SYMBOLS | TYPICAL NAME |
|---------------|------------------------------------------------------------------|
| GW | WELL GRADED GRAVELS; GRAVEL - SAND MIXTURES |
| GP | POORLY GRADED GRAVELS |
| GM | SILTY GRAVELS; GRAVEL - SAND - SILT MIXTURES |
| GC | CLAYEY GRAVELS; GRAVEL - SAND - CLAY MIXTURES |
| SW | WELL GRADED SANDS; SAND - GRAVEL MIXTURES |
| SP | POORLY GRADED SANDS |
| SM | SILTY SANDS |
| SC | CLAYEY SANDS; SAND - CLAY MIXTURES |
| ML | SILTS; SILTY, V FINE SANDS; SANDY OR CLAYEY SILTS |
| CL | CLAYS OF LOW TO MEDIUM PLASTICITY; SILTY, SANDY OR GRUVELY CLAYS |
| CH | HYDROPHILIC CLAYS OF HIGH PLASTICITY; FAT CLAYS |
| MH | ELASTIC SILTS; MICACEOUS OR DIATOMACEOUS |
| OL | ORGANIC SILTS AND ORGANIC SILTY CLAYS OF LOW PLASTICITY |
| OH | ORGANIC CLAYS OF MEDIUM TO HIGH PLASTICITY |

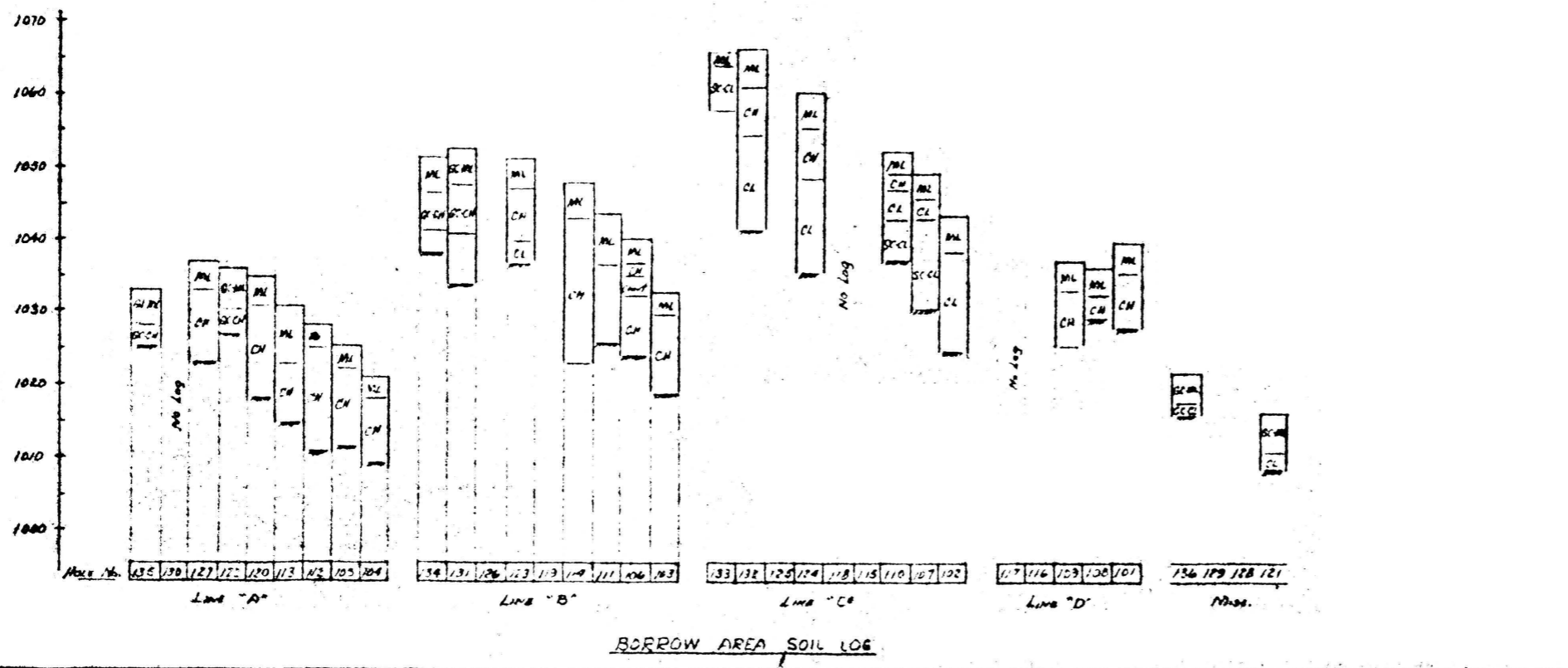

Sheet 2 Appendix B

| | | |
|----------|--------|------------------------------------|
| DESIGN | R.M.H. | MISSOURI CONSERVATION COMMISSION |
| DETAILED | R.M.H. | |
| CHECKED | R.L.H. | PHELPS CO LAKE LOG SOIL BORINGS |
| APPROVED | | SHEET 28 OF 28 |
| DATE | | DATE OCT. 1964 |
| | | JOB NO. 63-18 |

LITTLE PRAIRIE LAKE SITE

Phelps County

LOCATION: SE $\frac{1}{4}$, SE $\frac{1}{4}$, Sec. 21, T. 38 N., R. 7 W.

The lake site and watershed area are underlain by the Ordovician age Jefferson City dolomite. This bedrock formation consists of medium to massive beds of dolomite. It is relatively water tight. There has been little development of solution enlarged joints or an irregular bedrock surface due to weathering. The overlying soil consists of silt loam in the floodplain. Soil on the watershed slopes is made up of silt loam underlain by silty clay. Thus runoff occurs rapidly during and shortly after periods of rainfall. However, sustained flows are rather limited as the result of the combined effects of relatively impermeable soil cover and bedrock. With relatively low rates of water infiltration into the soil, bedrock springs and seeps are not common in this watershed state. Severe erosion and sediment control problems do not exist in this area.

The core trench for the dam was excavated to bedrock. Depths of excavation ranged from 5 to 10 feet. A positive cutoff was achieved on the surface of the bedrock.

The geologic setting is typical of this portion of the Salem Plateau Uplands. Perhaps the one most atypical feature is the general absence of Pennsylvanian deposits that cap the Jefferson City dolomite bedrock surface. Some exposures of Pennsylvanian deposits were observed within the lake and watershed area. However, they were not as persistent as is typical of these deposits on the Salem Plateau Uplands. Otherwise the setting is typical of this area in Missouri.

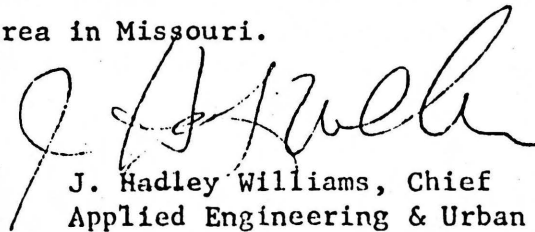

J. Hadley Williams, Chief
Applied Engineering & Urban Geology Section
Office of State Geologist
January 10, 1975

by: Jim Barks
U.S.G.S. Water Resources Division
Rolla, Missouri 65401

MISSOURI CONSERVATION COMMISSION, PHELPS COUNTY
LAKE SITE #21

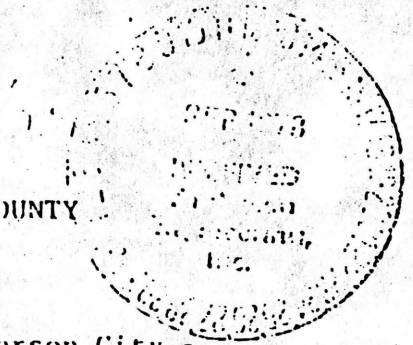

Bedrock exposed in the lake area is dolomite (Jefferson City - Cotter formation) and sandstone (lower Pennsylvanian). Outcrops are very limited within the lake area and the greater part of the site is soil covered with extensive pasture tracts. The drainage area is in pasture along the lower slopes with timber cover on the upper slopes and uplands. Topographic relief is low with typically rounded uplands and relatively gentle slopes. The slope in the area of the right (south) abutment is the steeper. The major portion of the proposed lake is in the S $\frac{1}{2}$ section 21, T. 38 N., R. 7 W. (Meramec Springs Quadrangle). The dam site is in the W $\frac{1}{2}$ SE $\frac{1}{2}$ SE $\frac{1}{2}$ section 21, T. 38 N., R. 7 W. The proposed water depth at the dam of 35 \pm feet will give a lake size of 100 acres.

The Jefferson City-Cotter formation is a dolomite with medium to massive rock beds separated by thin shale partings. Outcrops were observed only along the south side for a distance of 1,000 to 1,500 feet upstream of the damsite. From the limited number of exposures within the impoundment area the dolomite appears to be fairly tight. Shale partings will enhance the water tightness of the rock formation without affecting rock stability. Sandstone crops out in the bed of the stream and is present as boulders along the south slope. The sandstone represents fillings of pre-Pennsylvanian sinkholes in the dolomite. As these sinkholes are now inactive and represent an ancient pre-Pennsylvanian karst topography the sandstone filling them is not a continuous stratum. Water loss through the sandstone is not anticipated.

A number of sandstone boulders are present in the area of the right (south) abutment indicating that a sink structure filled with sandstone and clay may underlie the surface. It may be necessary to drill this abutment to insure founding the fill on sound rock. The left (north) abutment is soil covered. The inclination of the slope is such as to indicate that the soil may be of sufficient thickness to key this abutment into soil.

Customary drilling of the site should be deep enough to insure that potential water loss zones such as buried stream or slope deposits and deeply weathered bedrock are not left beneath the core of the dam.

Over-all, the site appears favorable from surface observations and warrants further consideration and subsurface exploration.

James A. Martin
James A. Martin
Missouri Geological Survey



MISSOURI DEPARTMENT OF CONSERVATION

MAILING ADDRESS:
P. O. Box 180
Jefferson City, Missouri 65102

STREET LOCATION:
2901 North Ten Mile Drive
Jefferson City, Missouri 65101

Telephone 314 - 751 - 4115
CARL R. NOREN, Director

September 7, 1978



Mr. Steve Brady
Anderson Engineering
730 North Benton
Springfield, Missouri 65802

Dear Mr. Brady:

The actual design notes for Little Prairie Lake near Rolla, Missouri, have been misplaced and due to our work schedule and your immediate need for the information, we do not feel it is warranted to redevelop all of this design information. However, I have gathered together the following information which should be adequate for comparing the spillway capacity with 50 percent of the Probable Maximum Flood in accordance with Corps guidelines.

Project Elevations

- a. Normal Pool Elevation (Principal Spillway) = 1032
- b. Emergency Spillway Crest Elevation = 1036
- c. Top Dam Elevation = 1039

Principal Spillway

- a. 9 feet x 9 feet concrete box drop inlet with crest elevation at 1032. Anti-vortex wall.
- b. 30 inch asbestos cement pipe
Invert elevation at inlet = 1024
Invert elevation at outlet = 995
Length = 400 feet
Hooded inlet on pipe
- c. Hydraulic Capacity

Weir crest will control for a few inches above drop inlet, at which time pipe will flow full.

Conduit capacity = Approximately 100 c.f.s.

Sheet 6 Appendix.

COMMISSION

Emergency Spillway

- a. Width = 200 feet
- b. Approximate Hydraulic Capacity

| <u>Depth (feet)</u> | <u>Q (c.f.s.)</u> |
|---------------------|-------------------|
| 1 | 540 |
| 2 | 1530 |
| 3 | 2800 |

Storage

Storage between the principal spillway and top of dam is based upon actual survey.

| <u>Elevation</u> | <u>Storage (ac-ft.)</u> |
|------------------|-------------------------|
| 1032 | 0 |
| 1035 | 324 |
| 1039 | 836 |

A storage curve can be plotted from this.

Drainage Area = 1,540 acres.

Design Floods

The crest of the emergency spillway is set at the 50-year flood frequency elevation.

The Maximum Probable Flood, Assumption A, was routed to establish the emergency spillway depth, freeboard, and width.

Sincerely,

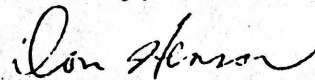

Donald L. Henson
Conservation Engineer

DLH:jjk

APPENDIX C.

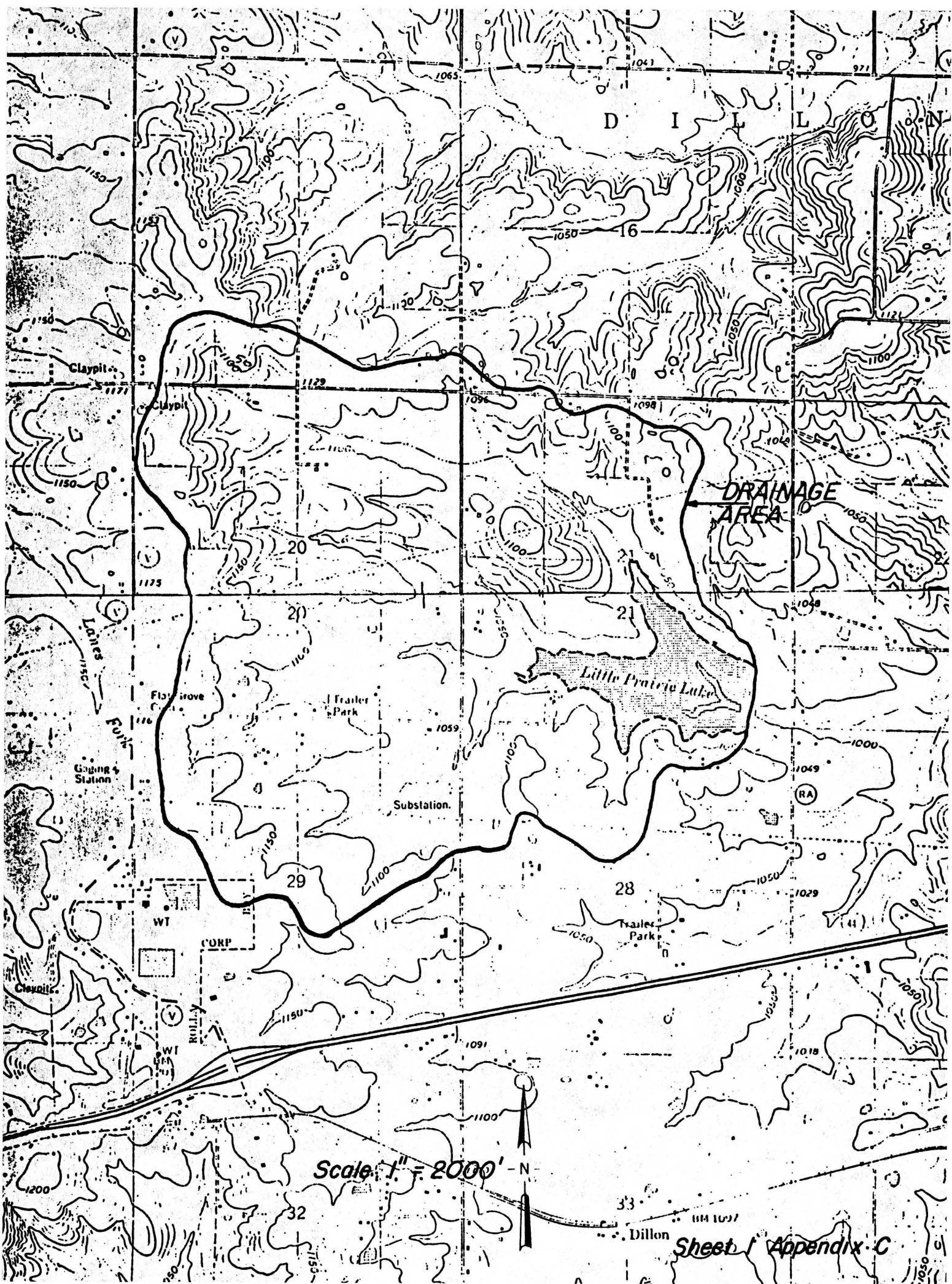

D I L L O N

**DRAINAGE
AREA**

Little Prairie Lake

Substation

Scale: 1" = 2000'

Sheet 1 Appendix C

HYDRAULIC AND HYDROLOGIC DATA

DESIGN DATA: From Construction Plans

EXPERIENCE DATA: No records are available. The apparent high water mark is at elevation 1036, which is 0.4 ft below the emergency spillway crest of 1036.4 ft and 4.0 ft above primary spillway crest of 1032.0 ft.

VISUAL INSPECTION: At the time of inspection, the pool was about 0.31 ft below the primary spillway crest due to evaporation.

OVERTOPPING POTENTIAL: Flood routings were performed to determine the overtopping potential. Since the dam is of intermediate size with a high hazard rating, a Spillway Design Storm of 100 percent of the PMF was prescribed by the guidelines. Reservoir area and storage data and the watershed drainage data were obtained from construction plans. A 5 minute interval unit graph was developed for this watershed area which resulted in a peak inflow of 2451 c.f.s. and a time to peak of 30 minutes. Application of the probable maximum precipitation minus losses resulted in a flood hydrograph peak inflow of 19,441 c.f.s. Rainfall distribution for the 24 hour storm was according to EM 1110-2-1411. Considering all factors, the combination of dam, spillway and storage is not sufficient to pass the PMF without overtopping. The embankment crest (El. 1039.5) would be overtopped by 1.78 ft at flood pool elevation 1041.24.

Fifty percent of the PMF was routed through the spillways. The resultant maximum pool elevation was 1040.03, 0.53 ft above the low elevation of the dam (1039.5). The peak outflow was 6913 c.f.s. The portion of the PMF that will just reach the top of the dam at elevation 1039.5 ft is about 39 percent. Inspection of the data indicates that 39 percent of the PMF relates to approximately 16 in. of watershed runoff. The 24 hour 100-year flood consists of 7.5 in. of rainfall for this area; therefore, the spillways will pass the 100-year flood without overtopping. For additional data see Summary of Dam Safety Analysis, Sheets 3 and 4.

OVERTOPPING ANALYSIS FOR Little Prairie Dam

INPUT PARAMETERS

1. Unit Hydrograph - SCS Dimensionless - Flood Hydrograph Package (HEC-1); Dam Safety Version Was Used.
Hydraulic Inputs Are As Follows:
 - a. Twenty-four Hour Rainfall of 26 Inches For 200 Square Miles - All Season Envelope
 - b. Drainage Area = 1540 Acres; = 2.41 Sq. Miles
 - c. Travel Time of Runoff 0.71 Hrs.; Lag Time 0.43 Hrs.
 - d. Soil Conservation Service Runoff Curve No. 85 (AMC III) Soil Group C
 - e. Proportion of Drainage Basin Impervious 0.06
 2. Spillways
 - a. Rating Curve for Primary Spillway: Prepared by
Hanson Engineers
 - b. Emergency Spillway
Length 200 Ft.; Side Slopes 4:1; C = 2.65
 - c. Dam Overflow
Length 1450 Ft.; Side Slopes Vertical C = 3.0
- Note: Combined Spillway and Dam Rating Data Provided To Computer on Y4 and Y5 Cards.

SUMMARY OF DAM SAFETY ANALYSIS

1. Unit Hydrograph
 - a. Peak - 2451 c.f.s.
 - b. Time to Peak 30 Min.
2. Flood Routings Were Computed by the Modified Puls Method
 - a. Peak Inflow (see Sheet 6)
50% PMF 9720 c.f.s.; 100% PMF 19,441 c.f.s.

b. Peak Elevation

50% PMF 1040.03 100% PMF 1041.28

c. Portion of PMF That Will Reach Top of Dam

39 %; Top of Dam Elev. 1039.5 Ft.

3. Computer Input and Output Data Sheets 5 and 6

A OVERTOPPING ANALYSIS FOR LITTLE PR PAGE 0001

A OVERTOPPING ANALYSIS FOR LITTLE PRARIE DAM (NO.2) (HEC-1) DAM SAFETY
 A CO. CODE 161 CO NAME PHELPS STATE ID NO. 30090 OWNER NO DEPT CONS.
 A HANSON ENGINEERS INC. DAM SAFETY INSPECTION (JOB NO. 03778)

| | | | | | | | | | | |
|------|---------------------------------------------------|------|------|--------|------|--------|-------|-------|--------|--------|
| B | 300 | | | | | | | | | |
| B1 | 5 | | | | | | | | | |
| J | 1 | 8 | 1 | | | | | | | |
| J1 | 0.2 | 0.3 | 0.4 | 0.5 | 0.6 | 0.7 | 0.8 | 1.0 | | |
| K | 0 | 1 | | | 0 | 0 | 1 | | | |
| K1 | INFLOW HYDROGRAPH COMPUTATION | | | | | | | | | |
| M | 1 | 2 | 2.41 | | 2.41 | 1 | | | 1 | |
| P | 0 | 26 | 102 | 120 | 130 | | | | | |
| T | | | | | | | -1 | -85 | | 0.06 |
| W2 | 0.71 | 0.43 | | | | | | | | |
| X | 0 | -1 | 2 | | | | | | | |
| K | 1 | 2 | | | | | | | 1 | |
| K1 | RESERVOIR ROUTING BY MODIFIED PULS AT PRAIRIE DAM | | | | | | | | | |
| Y | | | 1 | 1 | | | | | | |
| Y1 | 1 | | | | | | 1301 | -1 | | |
| Y4 | 1032 | 1033 | 1035 | 1036.4 | 1038 | 1039.5 | 1041 | 1043 | 1045 | 1048 |
| Y5 | 0 | 58 | 63 | 67 | 1179 | 3149 | 13782 | 38742 | 71866 | 133693 |
| \$A | 0 | 21.3 | 33.4 | 45.6 | 61 | 77 | 95 | 116 | 142 | 166 |
| \$E | 993 | 1011 | 1015 | 1019 | 1023 | 1027 | 1031 | 1035 | 1039.5 | 1043 |
| \$\$ | 1032 | | | | | | | | | |
| \$D | 1039.5 | | | | | | | | | |
| K | 99 | | | | | | | | | |

LITTLE PRAIRIE DAM

PEAK FLOW AND STORAGE (END OF PERIOD) SUMMARY FOR MULTIPLE PLAN-RATIO ECONOMIC COMPUTATIONS
 FLOWS IN CUBIC FEET PER SECOND (CUBIC METERS PER SECOND)
 AREA IN SQUARE MILES (SQUARE KILOMETERS)

| OPERATION | STATION | AREA | PLAN | RATIOS APPLIED TO FLOWS | | | | | | | |
|---------------|---------|-------|------|-------------------------|-----------------|-----------------|-----------------|-----------------|-----------------|-----------------|-----------------|
| | | | | RATIO 1 0.20 | RATIO 2 0.30 | RATIO 3 0.40 | RATIO 4 0.50 | RATIO 5 0.60 | RATIO 6 0.70 | RATIO 7 0.80 | RATIO 8 1.00 |
| HYDROGRAPH AT | 1 | 2.41 | 1 | 3888. | 5832. | 7776. | 9720. | 11664. | 13608. | 15553. | 19441. |
| | (| 6.24) | (| 110.10)(| 165.15)(| 220.20)(| 275.25)(| 330.30)(| 385.35)(| 440.40)(| 550.50) |
| ROUTED TO | 2 | 2.41 | 1 | 730. | 1898. | 3684. | 6913. | 9357. | 11401. | 13145. | 17277. |
| | (| 6.24) | (| 20.67)(| 53.74)(| 104.31)(| 195.76)(| 264.95)(| 322.83)(| 372.23)(| 489.22) |

SUMMARY OF DAM SAFETY ANALYSIS

| PLAN 1 | ELEVATION | INITIAL VALUE | SPILLWAY CREST | TOP OF DAM |
|--------|-----------|---------------|----------------|------------|
| | STORAGE | 1031.72 | 1032.00 | 1039.50 |
| | OUTFLOW | 1295. | 1322. | 2226. |
| | | 0. | 0. | 3149. |

| RATIO OF PMF | MAXIMUM RESERVOIR W.S. ELEV | MAXIMUM DEPTH OVER DAM | MAXIMUM STORAGE AC-FT | MAXIMUM OUTFLOW CFS | DURATION OVER TOP HOURS | TIME OF MAX OUTFLOW HOURS | TIME OF FAILURE HOURS |
|--------------|-----------------------------|------------------------|-----------------------|---------------------|-------------------------|---------------------------|-----------------------|
| 0.20 | 1037.35 | 0.00 | 1935. | 730. | 0.00 | 18.33 | 0.00 |
| 0.30 | 1038.55 | 0.00 | 2093. | 1898. | 0.00 | 17.08 | 0.00 |
| 0.40 | 1039.58 | 0.08 | 2236. | 3684. | 0.50 | 16.58 | 0.00 |
| 0.50 | 1040.03 | 0.53 | 2302. | 6913. | 1.42 | 16.25 | 0.00 |
| 0.60 | 1040.38 | 0.88 | 2353. | 9357. | 2.00 | 16.25 | 0.00 |
| 0.70 | 1040.66 | 1.16 | 2395. | 11401. | 2.67 | 16.17 | 0.00 |
| 0.80 | 1040.91 | 1.41 | 2433. | 13145. | 3.33 | 16.17 | 0.00 |
| 1.00 | 1041.28 | 1.78 | 2489. | 17277. | 4.25 | 16.17 | 0.00 |

APPENDIX D

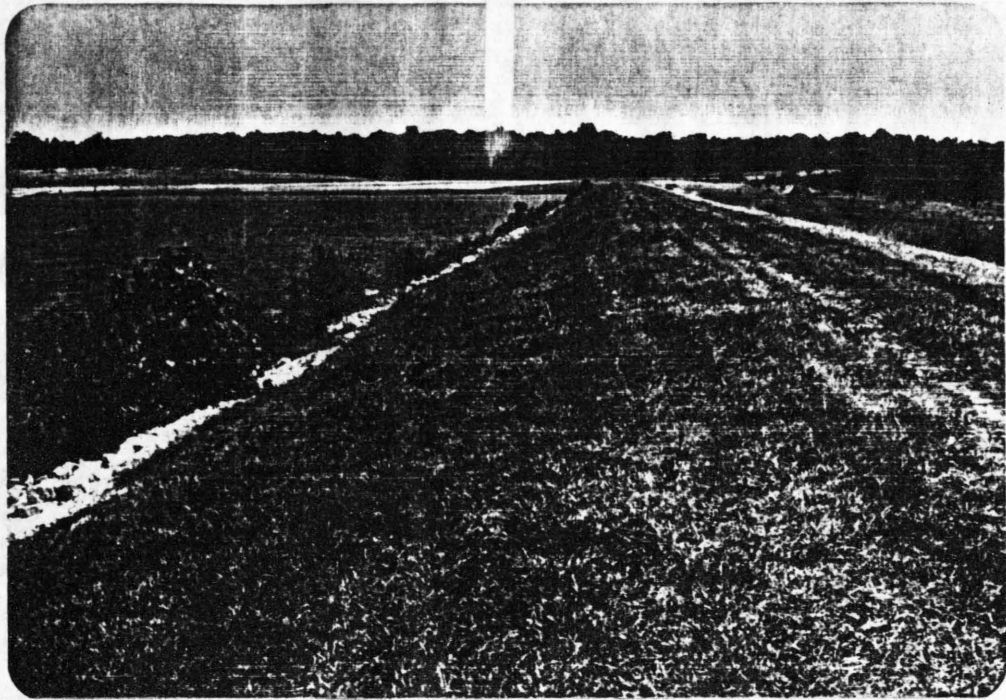

Crest of Dam - Looking North

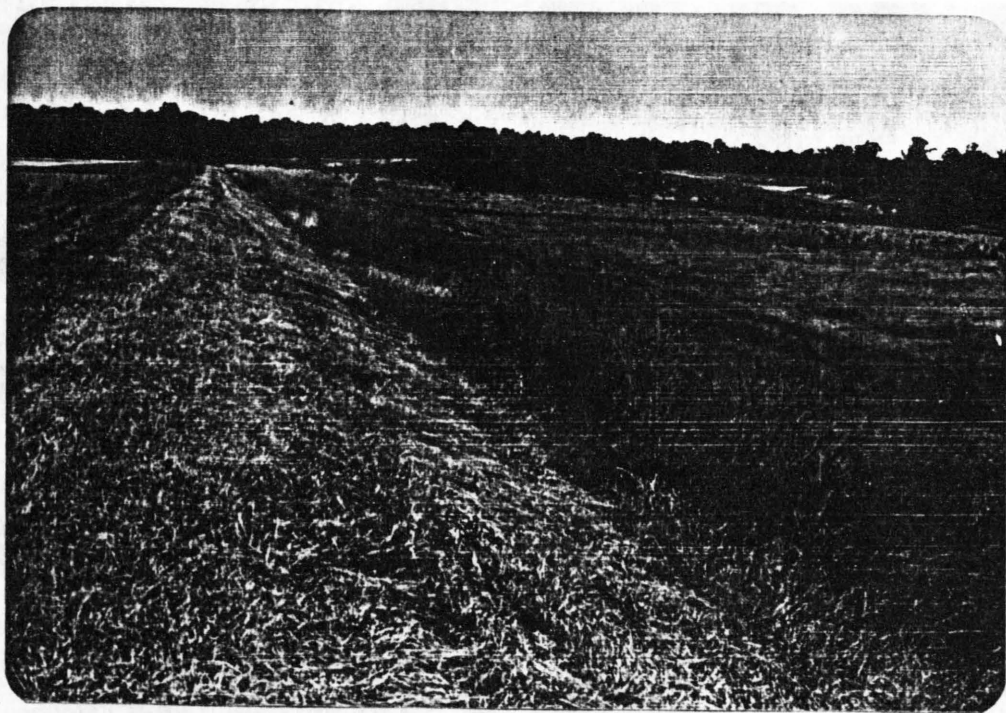

Downstream Face - Looking North

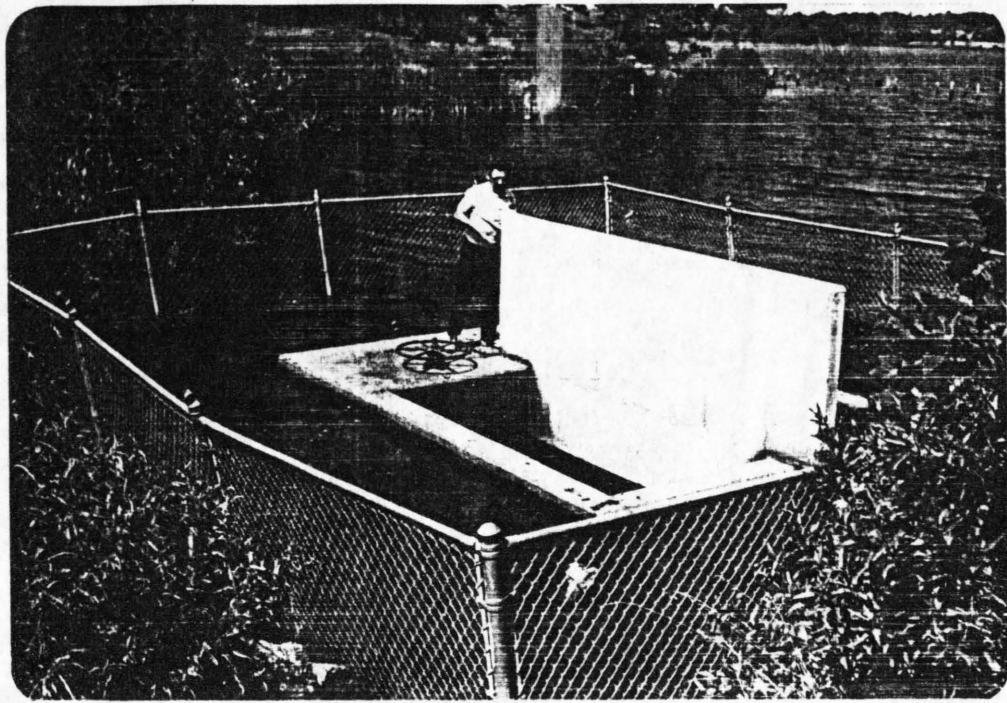

Primary Spillway Structure

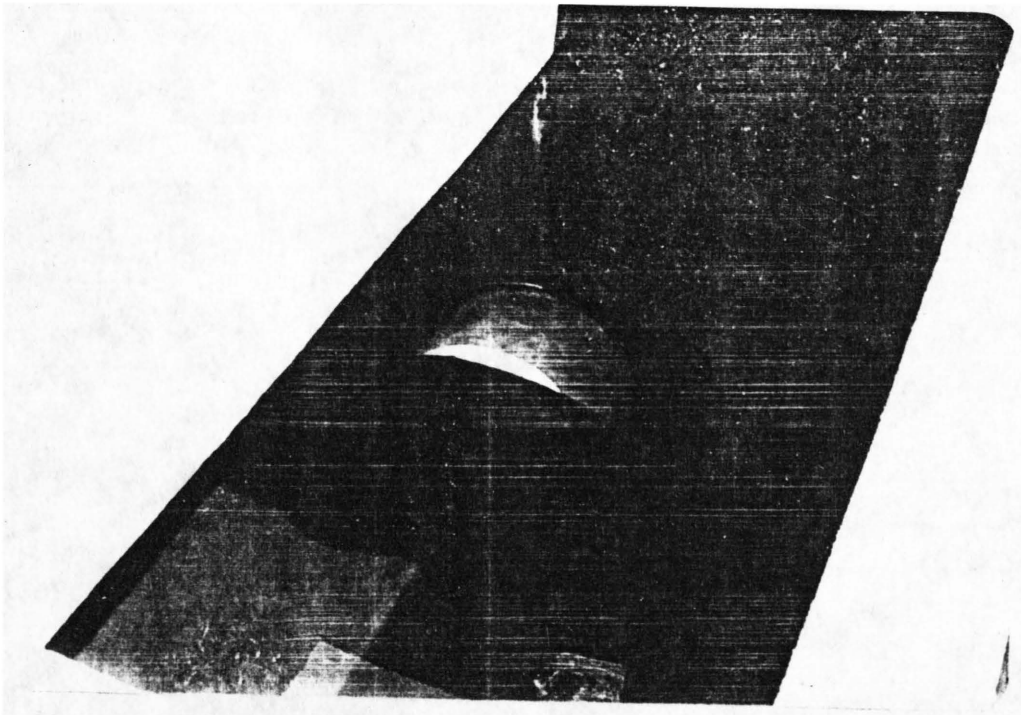

Primary Spillway - Outflow Pipe

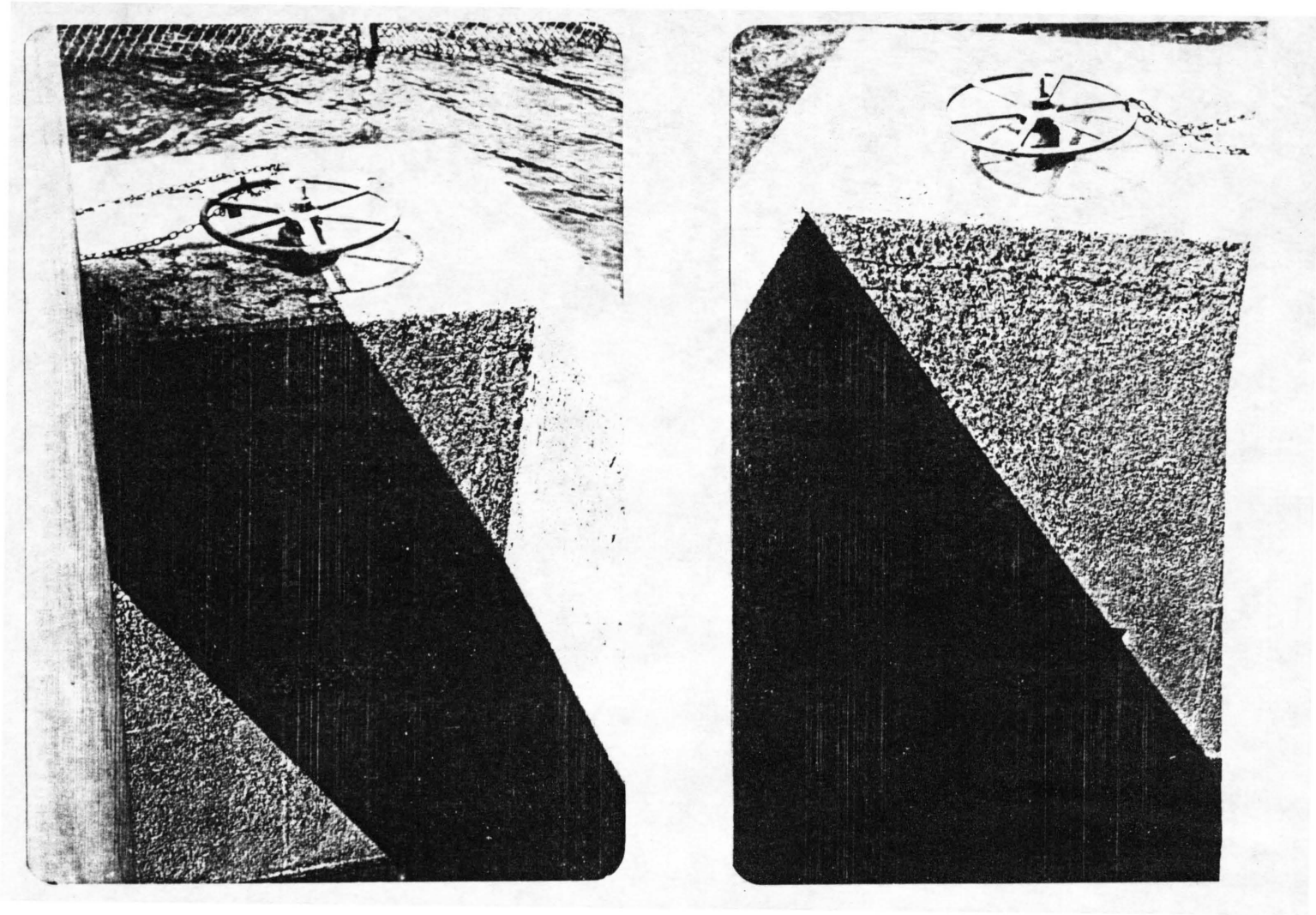

Primary Spillway - Upper and Lower Slide Gates

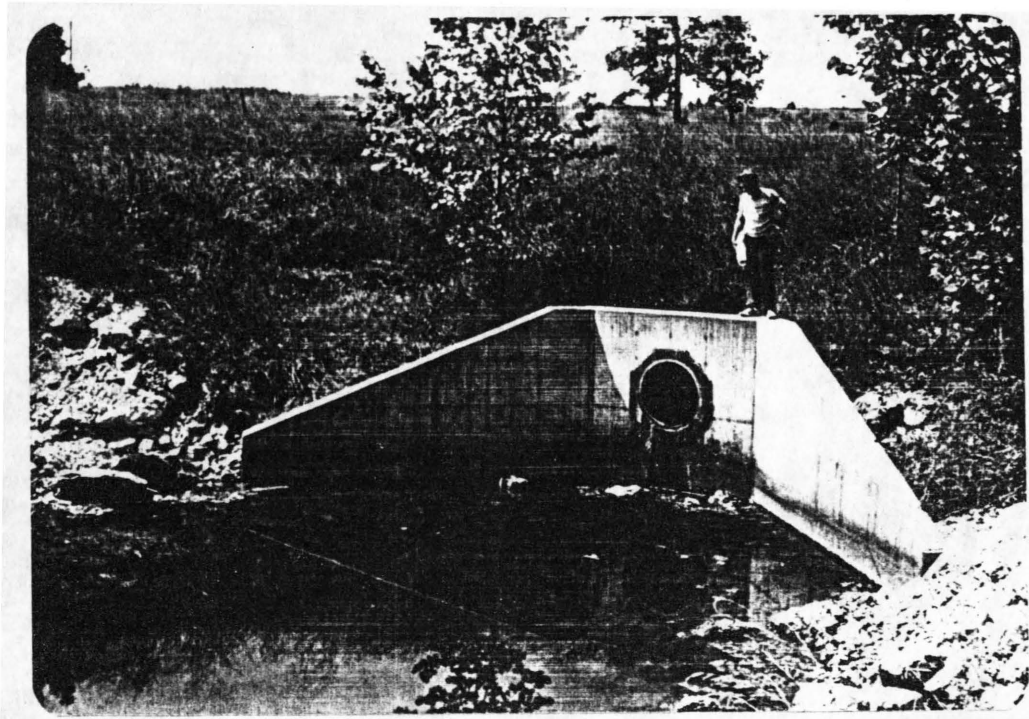

Outlet Structure - Primary Spillway

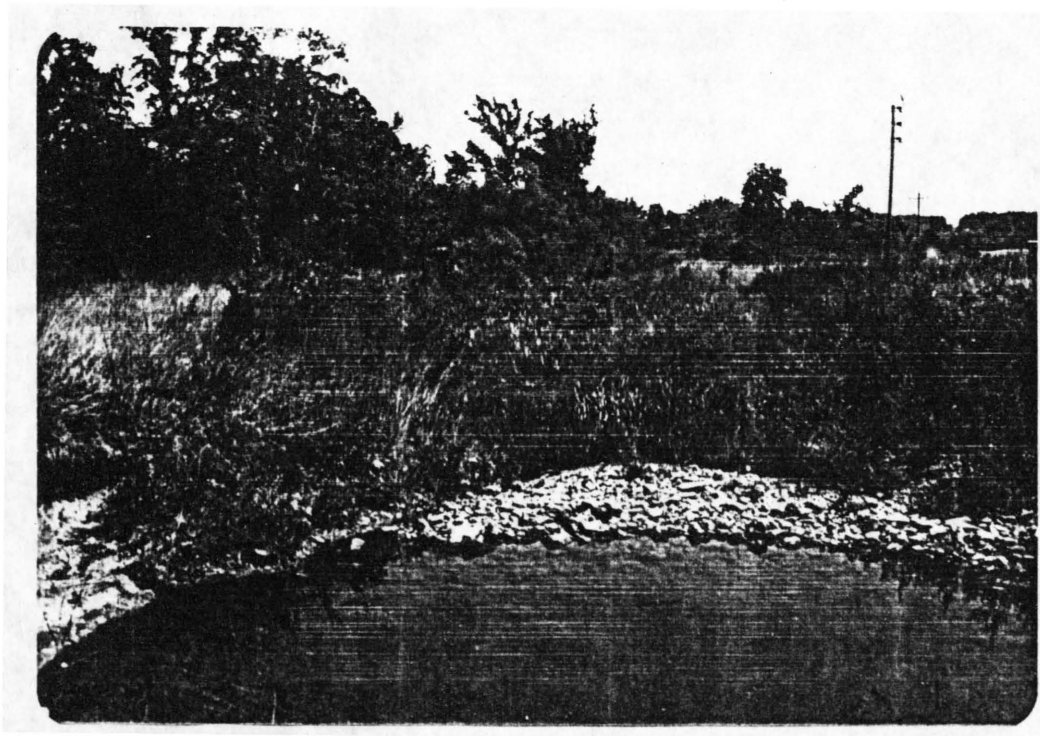

Outlet Channel - Primary Spillway

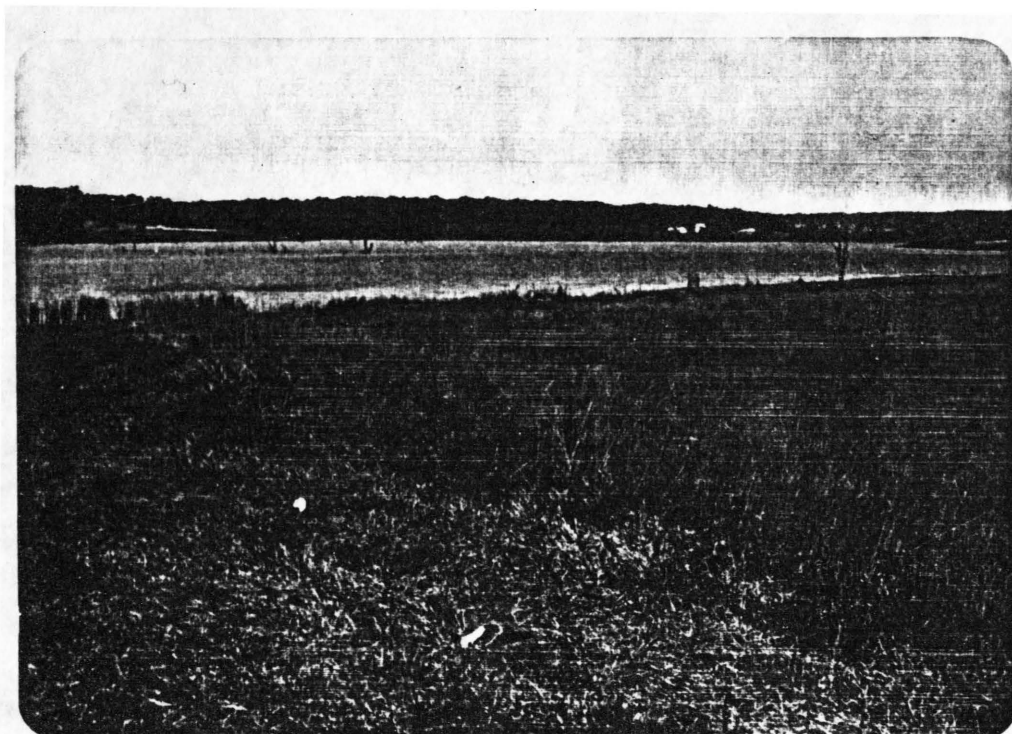

Emergency Spillway - Looking Upstream



Emergency Spillway - Looking Downstream