

Aug 11th - Aug 16th

# Time-Dependent Bearing Capacity Increase of Uniformly Driven Tapered Piles- Field Load Test

Mahmoud Ghazavi

*K.N.Toosi University of Technology, Tehran, Iran*

Hossein Ali Ahmadi

*Isfahan University of Technology, Isfahan, Iran*

Follow this and additional works at: <http://scholarsmine.mst.edu/icchge>



Part of the [Geotechnical Engineering Commons](#)

---

## Recommended Citation

Ghazavi, Mahmoud and Ahmadi, Hossein Ali, "Time-Dependent Bearing Capacity Increase of Uniformly Driven Tapered Piles- Field Load Test" (2008). *International Conference on Case Histories in Geotechnical Engineering*. 38.

[http://scholarsmine.mst.edu/icchge/6icchge/session\\_01/38](http://scholarsmine.mst.edu/icchge/6icchge/session_01/38)

This Article - Conference proceedings is brought to you for free and open access by Scholars' Mine. It has been accepted for inclusion in International Conference on Case Histories in Geotechnical Engineering by an authorized administrator of Scholars' Mine. This work is protected by U. S. Copyright Law. Unauthorized use including reproduction for redistribution requires the permission of the copyright holder. For more information, please contact [scholarsmine@mst.edu](mailto:scholarsmine@mst.edu).



## **TIME-DEPENDENT BEARING CAPACITY INCREASE OF UNIFORMLY DRIVEN TAPERED PILES- FIELD LOAD TEST**

### **Mahmoud Ghazavi**

Associate Professor, Civil Engineering Department,  
K. N. Toosi University of Technology, Tehran, Iran  
Email: ghazavi\_ma@kntu.ac.ir

### **Hossein Ali Ahmadi**

Former Graduate Student, Civil Engineering Department, Isfahan  
University of Technology, Isfahan, Iran

### **ABSTRACT**

This paper describes the results of field load tests on concrete tapered and straight-sided piles driven into a cohesive saturated ground. The piles were driven into a depth of 12 m at a close distance using diesel hammer machine. The soil profile consisted mainly of soft CL and ML in the Unified Soil Classification System. Two piles were tested initially after 35 days from the installation date using maintained load test procedure according to ASTM D1143-81. Then similar tests were performed on two piles after 289 days following the installation date. The results showed the capacities of both piles were roughly identical after 35 days from the installation time. The load-settlement behaviour of tapered showed stiffer than that of the straight-sided pile. After 289 days from the installation date, both piles offered greater bearing capacity values. The long term bearing capacity of a tapered pile was about 80% greater than that of a uniform pile of the same volume and length. In long term, for a given load level applied to the pile heads, the tapered pile offered greater stiffness than the straight-sided pile. This indicates the advantageous use of tapered piles instead of straight sided piles of the same volume and length.

### **INTRODUCTION**

In some cases for instance when the soft ground is present, piled foundations are normally used to transmit heavy loads from supported structures to the ground. The use of piles in practice has sharply increased in recent years. This vast application has led to improvement of pile analyses to facilitate the correct use of piles. These analysis methods involve analytical (Randolph and Wroth, 1978), subgrade reaction (Chow, 1986), integral equation (Poulos and Davis, 1980), and finite elements (Zaman et al., 1993; De Nicola and Randolph, 1993). In addition, field and laboratory tests have been extensively performed on piles. Also these theoretical and experimental approaches are significant, they have mainly concentrated on straight-sided piles and the characteristics of tapered piles have been rarely investigated.

The behaviour of tapered piles has not yet been fully understood. There are few publications presented on this subject. Rybnikov (1990) performed field tests on bored cast-in-place piles in the former Soviet Union. He performed a loading test on a bored cast-in-place fully tapered pile, 4.5 m long with head and toe diameters of 600 mm and 400 mm embedded in a relatively homogeneous sandy soil deposit in the Irtysh Pavlodar region of the former Soviet Union. The soil consisted of 5.8 m of sandy loam underlain by 2.1 m of clayey loam and 2.4 m of sand. The results of these tests

showed that tapered piles had 20-30% more bearing capacity than uniform piles of the same volume and mean radius. The capacity of driven piles increased to 250-300%, while the costs involved to erect such foundations were also remarkably reduced, sometimes to 50% of those of uniform piles (Zil'berberg and Sherstnev, 1990).

Kodikara and Moore (1993) carried out a theoretical model to account for the slip between the soil and the pile. This was verified by field test results reported by Rybnikov (1990).

Laboratory tests on tapered wooden pile models embedded in sand were carried out by Kurian and Srinivas (1995). The piles were 700 mm long and of circle, square, and triangle cross sections. They found that tapered models had about 10% capacity more than uniform piles. In addition, tapered piles had settlement about 25% less than uniform piles under identical axial load.

Ghazavi et al. (1996) developed a one-dimensional effective stress approach based on the finite element method to determine the bearing capacity of tapered piles embedded in cohesive soils. This approach was verified by field test results.

Wei and El Naggar (1998) conducted comprehensive laboratory tests and explored the effects of the taper angle and confining pressures on pile characteristics. They reported

more capacity for tapered piles embedded in sand compared with cylindrical piles.

Another approach for pile solution, termed “Segment by Segment Method” (SSM) was applied to uniform piles under axial compressive loads (Ghazavi et al. 1997a), uplift static loads (Ghazavi et al., 1997b), and axial harmonic vibrations (Ghazavi, 2002).

In this paper, the field loading test results for tapered and straight-sided piles driven into cohesive ground and loaded statically in the axial direction are explained. The load-settlement response of both piles, especially the time-dependent capacity value of driven non-uniform piles in cohesive soil is illustrated.

### PILE INSTALLATION PROCEDURE

Both piles shown in Figs. 1 and 2 were driven into the ground using a diesel hammer. Two precast concrete piles were constructed in the test site as illustrated in Figs. 1 and 2. The lengths of both piles were 12.5 m. Both piles had square cross sections. The first pile was uniform and the second one was fully tapered.

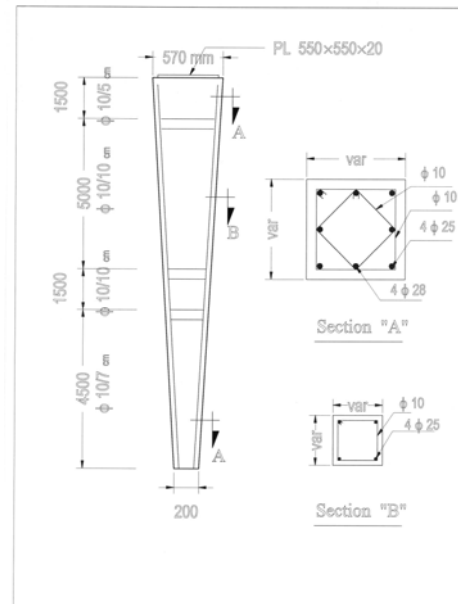

Fig. 2. Details of precast test tapered pile

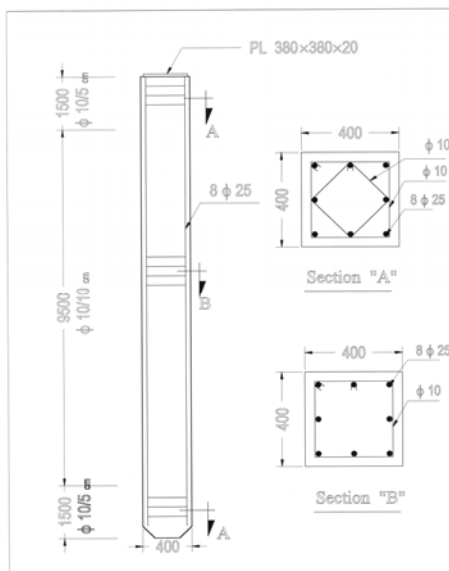

Fig. 1. Details of precast test uniform pile

Two precast concrete piles were fully embedded at the time of tests. The volume of concrete for constructing each pile was 1.92 m<sup>3</sup>. The head and the toe diameters of the tapered pile were 57 cm and 20 cm, respectively. The taper angle was therefore about 0.9°.

Two piles were driven to a depth of 12 m (Figure 3). The distance between the two piles was 9 m. This distance may be sufficient to have no interference between the two piles during pile driving and static loading tests (Poulos and Davis, 1980).



Fig. 3. Pile driving start

The test site was in Mahshahr area of Khoozestan, a south Province of Iran. The soil at the site consists of a thick CL and ML in the Unified Soil Classification, as reported by geotechnical consulting engineers. The plasticity index of the soil was averagely 22%. The SPT values were roughly identical at depth and accounted for about 5. Water table level was at a depth of about 1 m from the ground surface. The geotechnical data were reported 5 years ago and after that, according to the authorities, there had been traffic and other

loading on the ground as the site had been subjected to traffic and temporary loading. Therefore, the soil might have been slightly improved. Therefore, the results do not affect our comparative study for the load-carrying capacities of two piles.

### PROCEDURE OF STATIC LOADING TEST

After pile installation, the two piles were left first for 35 days after installation that that reconsolidation occurred. For a period of about 9 months, some static loading tests were performed on both piles using the procedure recommended by ASTM D1143-81 (Figure 4). The results of tests showed a significant variation for both piles within time especially for the tapered pile. The results are presented in subsequent section.



Fig. 4. Static loading test on pile

### RESULTS

Following the pile installation, the first static loading tests were performed on straight-sided and tapered piles after 35 days from the pile driving date. The load-settlement of uniform and tapered piles was determined in tests. Fig. 5 illustrates the results for both piles tested after 35 days.

To determine the capacity of each pile, the well known methods such as Davisson offset, Chin-Kondner extrapolation, and Decourt extrapolation were used. As seen in Fig. 5, for small displacement, the tapered pile has slightly greater stiffness. The values of bearing capacity of two piles are roughly identical. After 35 days from the installation time, both piles have a capacity of about 30 tons.

The characteristics of long-term load-carrying response of uniform and tapered piles are illustrated in Figure 6. These results were obtained after 289 days from the installation time. As seen, for small displacement for two piles, the load-settlement response is linear, and subsequently becomes nonlinear. In addition, for the tapered pile, after small

deformation, the tapered pile becomes stiffer than the uniform pile.

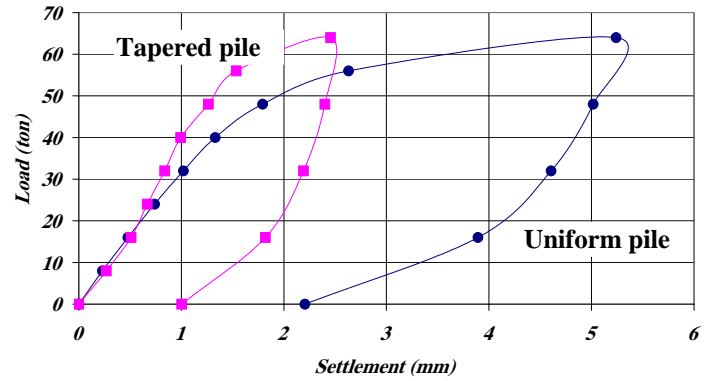

FIG. 5. Load-settlement behaviour of piles at 35 days after installation

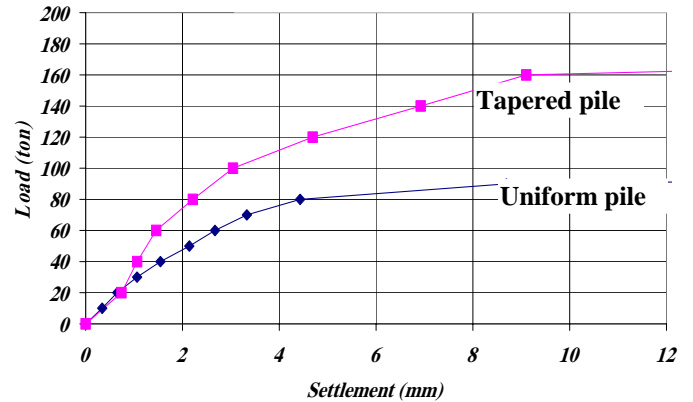

FIG. 6. Load-settlement behaviour of piles at 289 days after installation

According to Figure 6, the compression capacity of the uniform pile 289 days after installation was found to be about 90 tons using Chin-Kondner and Decourt extrapolations. This value for the tapered pile was found to be about 162 tons. This means the tapered pile has about 80% more long term capacity than the uniform pile.

As shown in Figure 6, the tapered pile has greater long term capacity than the uniform pile of the same volume and length. This is attributed to the greater pore pressure generation along the shaft of the tapered upon pile driving, compared with the straight-sided pile. As a result of such greater pore pressure dissipation, a greater long term capacity is obtained. More field and laboratory tests are routinely required to generalise the advantageous aspects of tapered piles over straight-sided piles.

## CONCLUSIONS

Field loading tests have been performed on a uniform and a concrete tapered pile of lengths of 12 m and with the same material volume. The piles were driven into a cohesive saturated soil profile and then tested using the procedure outlined by ASTM D1143-81 to determine the time-dependent capacities of both piles. The tests indicate that the capacity of both piles were roughly identical shortly after installation. However, this capacity increases with time elapsed after driving time. The uniform pile shows about 90 ton capacity 289 days following the pile installation. For the tapered pile, this value accounts for about 162 tons. In addition, the tapered pile showed a greater stiffness than the uniform pile. It may be generally stated that the time-dependent capacity of a tapered pile is well greater than of a uniform pile of the same length and volume. It is recommended to perform more experiments to characterise the behaviour of tapered piles.

## REFERENCES

- ASTM, D 1143-81, [1985]. "Standard Test Method for Piles Under Static Axial Compressive Load". Annual Book of ASTM Standards, Vol. 04.08, pp. 239-254.
- Carter, J.P., Randolph, M.F., and Wroth, C.P. [1979]. "Stress and Pore Pressure Changes in Clay During and After the Expansion of a Cylindrical Cavity". Int. J. Num. Anal. Methods. Geomech., Vol. 3, pp 305-322.
- Chow, Y.K. [1986]. "Analysis of Vertically Loaded Pile Groups". Int. J. Num. Anal. Methods. Geomech., Vol. 10, No. 1, pp 59-72.
- Davison, M.T., [1972]. "High Capacity Piles". Proceedings of Lecture Series on Innovations in Foundation Construction, American Society of Civil Engineers, ASCE, Illinois Section, Chicago, March 22, pp. 81-112.
- Decourt, L., [1999]. "Behavior of Foundations under Working Load Conditions." Proceedings of the 11th Pan-American Conference on Soil Mechanics and Geotechnical Engineering, Foz Dulguassu, Brazil, Vol. 4, pp. 453-488.
- De Nicola, D.A., and Randolph, M.F. [1993]. "Tensile and Compression Shaft Capacity of Piles in Sand". J. Geotech. Engrg, ASCE, 119(12), pp 1952-1973.
- Fellenius, B.H., [1980]. "The Analysis of Test Results from Routine Pile Loading Tests". Ground Engrg, London, Vol. 13, No. 6, pp. 19-31.
- Fellenius, B.H., Brusey, W.G., and Pepe, F., [2000]. "Soil Set-Up, Variable Concrete Modulus, and Residual Load for Tapered Instrumented Piles in Sand. University of Massachusetts Amherst.
- Fellenius, B.H., [2001]. "What Capacity to Choose from the Results of a Static Loading Test". (<http://www.Fellenius.com>).
- Ghazavi, M. [2002]. Vertical Vibration of Deep Foundations in Layered Deposits". In Proceedings of Iranian Third International Seminar on Soil Mechanics and Geotechnical Engineering (ISSMGE), Tehran, Iran, Vol. I, 223-228.
- Ghazavi, M., Williams, D.J., and Morris, P.H. [1996]. "Analysis of Statically Loaded Tapered Piles in Layered Media". Proc. 2nd Int. Symp. Struct. Found. in Civil Engrg, Hong Kong, pp 163-169.
- Ghazavi, M., Williams, D.J., and Morris, P.H. [1997a]. "Analysis Of Axially Loaded Piles Embedded In Layered Deposits. In Proceedings of the 2nd International Conference on the Application of Numerical Methods in Engineering, Universiti Pertanian Malaysia, Selangor, Malaysia, 335-344.
- Ghazavi, M., Williams, D.J., and Morris, P.H. [1997b]. "Analysis of Piles Subjected to Uplift Loads". In Proceedings 2nd International Symposium on Structures and Foundations in Civil Engineering, Hong Kong, 177-183.
- Hansen Hansen, J.B., [1963]. "discussion on Hyperbolic Stress-Strain Response of Cohesive Soils". J. Soil Mech. Found. Engrg, ASCE, Vol. 89, SM4, pp. 241-242.
- Kodikara, K.K., and Moore, I.D. [1993]. "Axial Response of Tapered Piles in Cohesive Frictional Ground". J. Geotech. Engrg, ASCE, Vol. 119, pp 675-693.
- Kurian, N.P. and Srinivas, M.S. [1995]. "Studies on the Behaviour of Axially Loaded Tapered Piles by the Finite Element Method". Int. J. Num. Anal. Methods. Geomech., vol. 19, pp 869-888.
- Poulos, H.G., and Davis, E.H. [1980]. "Pile Foundation Analysis and Design". John Wiley and Sons, Inc., New York, N.Y.
- Randolph, F.M., and Wroth, C.P. [1978]. "Analysis of Deformation of Vertically Loaded Piles". J. Geotech. Engrg, ASCE, 104(12), pp 1465-1488.
- Rybnikov, A.M. [1990]. "Experimental Investigation of Bearing Capacity of Board-Cast-in-Place Tapered Piles". Soil Mech. Found. Engrg, Vol. 27 No. 2, pp 48-52.
- Tomlinson, M.J., [1980]. "Pile Design and Construction Practice". Viewpoint Publication, London.
- Wei, J., and El Naggar, M.H. [1998]. "Experimental Study of Axial Behaviour of Tapered Piles". Can. Geotech. J , Vol. 35, pp 641-654.

Zaman, M.M., Najjar, Y.M., and Muqtadir, A. [1993]. "Effects of Cap Thickness and Pile Inclination on the Response of a Pile Group Foundation by a Three-Dimensional Nonlinear Finite Element Analysis". *Comp. Geotech.*, Vol. 15, No. 2, pp 65-86.

Zil'berberg, S.D., and Sherstnev, A.D. [1990]. "Construction of Compaction Tapered Pile Foundations (from Experience of the "Valdespetsstroj" Trust)". *Soil Mech. Found. Engrg*, Vol. 27, No. 3, pp 96-101.