

11-1-2001

# A Comparison of FACTS Integrated with Battery Energy Storage Systems

Lin Zhang

Shen Chen

Stan Atcitty

Mariesa Crow

Missouri University of Science and Technology, [crow@mst.edu](mailto:crow@mst.edu)

Follow this and additional works at: [http://scholarsmine.mst.edu/ele\\_comeng\\_facwork](http://scholarsmine.mst.edu/ele_comeng_facwork)



Part of the [Electrical and Computer Engineering Commons](#)

---

## Recommended Citation

L. Zhang et al., "A Comparison of FACTS Integrated with Battery Energy Storage Systems," *Proceedings of the 2001 IEEE PES Transmission and Distribution Conference and Exposition (2001, Atlanta, GA)*, vol. 2, pp. 1151-1155, Institute of Electrical and Electronics Engineers (IEEE), Nov 2001.

The definitive version is available at <http://dx.doi.org/10.1109/TDC.2001.971421>

This Article - Conference proceedings is brought to you for free and open access by Scholars' Mine. It has been accepted for inclusion in Electrical and Computer Engineering Faculty Research & Creative Works by an authorized administrator of Scholars' Mine. This work is protected by U. S. Copyright Law. Unauthorized use including reproduction for redistribution requires the permission of the copyright holder. For more information, please contact [scholarsmine@mst.edu](mailto:scholarsmine@mst.edu).

# A Comparison of FACTS Integrated with Battery Energy Storage Systems

L. Zhang C. Shen M. L. Crow  
Electrical and Computer Engineering  
University of Missouri-Rolla, Rolla, MO 65409-0040

S. Atcitty  
Energy Storage Systems Analysis & Development  
Sandia National Laboratories, Albuquerque, NM 87185-0613

*Abstract*— The integration of energy storage into FACTS devices lead to increased controller flexibility by providing decentralized active power capabilities. Combined FACTS/ESS can improve power flow control, oscillation damping, and voltage control. This paper presents a comparison between the dynamic performance of a StatCom, a StatCom/BESS, an SSSC, an SSSC/BESS, and a UPFC. Experimental verification is also presented.

*KEYWORDS.* FACTS, energy storage, power system dynamic stability

## I. INTRODUCTION

THE use of FACTS devices in a power system provide increased transmission control and flexibility. The current trend in FACTS devices is to incorporate a voltage-sourced-converter (VSC) topology either in shunt (StatCom) or in series (SSSC or UPFC) with the transmission system. A capacitor is used to provide the dc voltage of the VSC. The power conversion systems required for battery energy storage systems (BESS) are similar to the VSC of FACTS devices, thus a BESS can serve the dual purpose of providing the dc voltage and active power capabilities. In most applications, the cost of the FACTS electronics system dominates the cost of the ESS [1]. A combined FACTS/BESS system thus has comparable cost and can provide the FACTS device with four quadrant control [2] creating greater appeal to transmission service providers.

Currently, there is a lack of understanding of the capabilities of FACTS/ESS as compared to FACTS. While the FACTS/ESS combination has been proposed in theory [3], the development of FACTS/ESS systems has lagged far behind that of FACTS alone. This paper provides a comparison of FACTS and FACTS/BESS for the power system

applications of power flow control, oscillation damping, and voltage control. Specifically, this paper will compare the dynamic performance of StatCom, StatCom/BESS, SSSC, SSSC/BESS, and UPFC systems.

## II. EXPERIMENTAL FACTS/BESS SYSTEM

The control objective of a FACTS or FACTS/BESS device is to maintain system performance according to some pre-set or user defined scheme. The control objective may be voltage control, steady-state power flow control, oscillation damping, or transient stability improvement. Several FACTS and FACTS/BESS control schemes have been developed and implemented on a scaled laboratory system.

The multi-use hardware set-up shown in Figure 1 has been constructed at the University of Missouri-Rolla [4]. By proper switch settings, a StatCom, SSSC, or UPFC can be realized. The experimental FACTS devices were interfaced with a battery set that consists of 34 VLRA super-gel batteries in two strings supplying 204 V dc. The FACTS/BESS system consists of two single three-phase inverters, LC filters and two transformers. The PC-DSP-based control system includes a host PC, two signal processing boards with an embedded 40 MHz TI TMS32051 and several interface boards. The host PC provides real-time monitoring, control, coordination and protection to the two DSP-based slave subsystems. The PC also serves as a testbench to provide on-line and off-line analysis of system performance. The DSP-based data acquisition subsystem (DAS) acquires and pre-processes 8 or 16 channel analog signals from the FACTS device. Real-time signal processing, such as digital filtering, space phasor calculation, and system frequency measurement, is implemented in the DAS. All the preprocessed results such as  $P$ ,  $Q$ ,  $V_{rms}$ , and  $I_{rms}$  are exported to the host PC for the control algorithm. The system controllers are fully programmable so that new controls can be implemented rapidly. The StatCom/BESS is rated at 3kVA and the SSSC/BESS is rated at 2.5kVA.

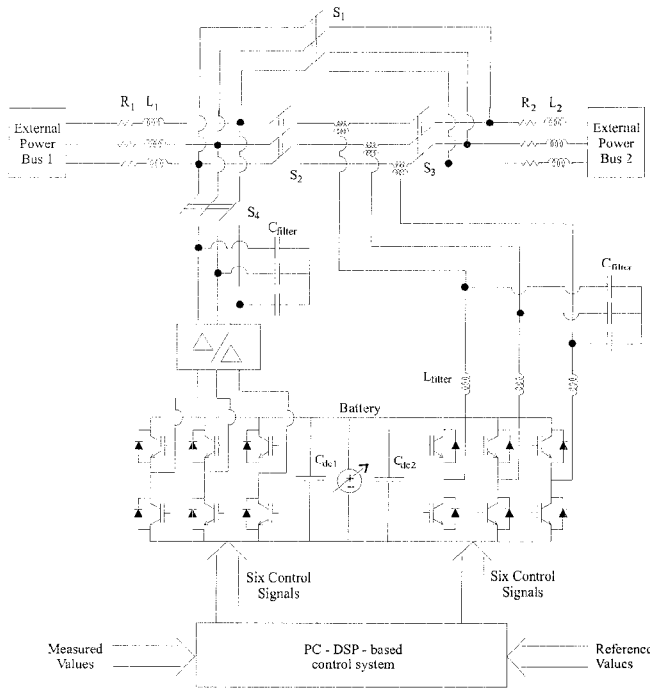

Figure 1 – Laboratory set-up of FACTS/BESS

### III. FACTS CONTROL

The control objective of the FACTS/BESS is to maintain system performance according to some pre-set or user defined scheme. The control objective may be voltage control, power flow control for oscillation damping, or transient stability improvement. For transmission capacity control, the FACTS device injects active and/or reactive power to achieve the desired system response. The PC-DSP-based controller converts the commanded values into switching commands for the FACTS devices to regulate the gain and angle of the VSC. The primary objective of a shunt FACTS controller (such as a StatCom) is to control the voltage at the system bus. However, with energy storage, the StatCom/BESS can impact both voltage and active power flow on the line. The controller affect on these attributes can be decoupled such that the modulation index  $k$  controls the active power flow and the phase angle  $\alpha$  controls the firing angle  $\alpha$ . A PI controller based on this assumption is shown in Figure 2

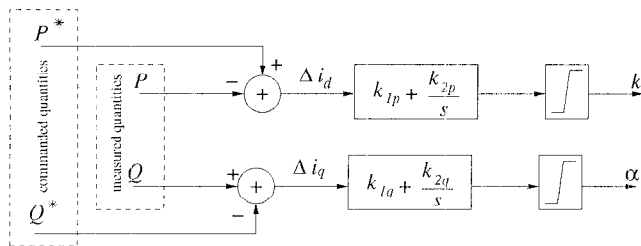

Figure 2 – PQ Decoupled PI Control Block Diagram for StatCom/BESS

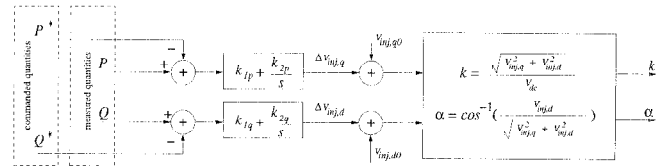

Figure 3 – PQ Decoupled PI Control Block Diagram for SSSC/BESS

The main objective of a series FACTS controller (such as an SSSC or UPFC) is to control the power flow on a transmission line. For optimal control of transmission capacity, it is desired to have a controller that can achieve independent active and reactive power response. To accomplish this goal, a decoupled PI controller is proposed that can produce the desired switching commands from independent active and reactive power commands. In the series controllers, the active power and reactive power are closely coupled to the  $d$  and  $q$  axis injected voltage. Thus, a decoupled controller can be developed as a function of these quantities rather than  $P$  and  $Q$  directly. A decoupled PI controller for the SSSC/BESS system is shown in 3. A decoupled UPFC controller can be constructed as a combination of the SSSC and StatCom controllers.

The proposed decoupled controls have been applied to the laboratory set-up described previously. The controls have also been simulated using a detailed (switch-level) model and the state-space model.

The results of the simulated control are shown concurrently with the experimental results, where the solid lines indicate the measured power dynamics, and the dashed lines indicate the predicted dynamics. The switch-level simulation results were obtained from a detailed model of the laboratory system built in the software package PSCAD/EMTDC. The results of the state-space model are given by the dash-dot lines. The simulation models use the measured values of the laboratory parameters of the SSSC/BESS system (transformer reactances, filter LCs, etc.) [5].

The StatCom/BESS case shown in Figure 4 keeps the the reference reactive power constant while decreasing the reactive power control target from 0 to -500 Var (Figure 4 (a)), and decreasing the active power from 0 to -500 W (Figure 4 (b)). A similar experiment is repeated for the SSSC/BESS in Figure 5. In this figure, the reactive power across the line is decreased from 750 to 355 Var (Figure 5 (a)), and the active power is decreased from 400 to 50 W (Figure 5 (b)). The simulation (predicted) results show the close correspondance between the experimental and the predicted response of the SSSC/BESS. These results support the use of the proposed PQ decoupled PI controls in FACTS/BESS applications.

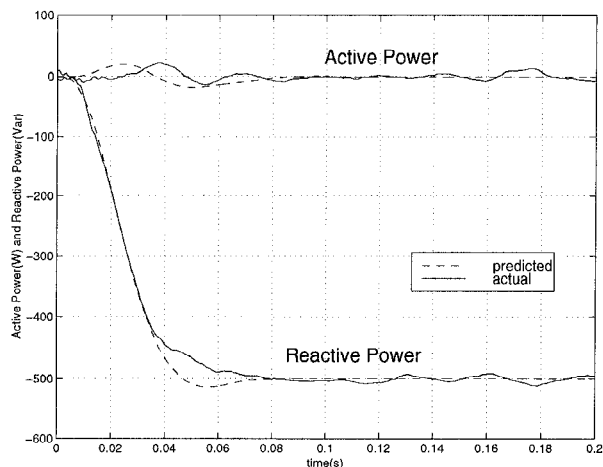

(a)

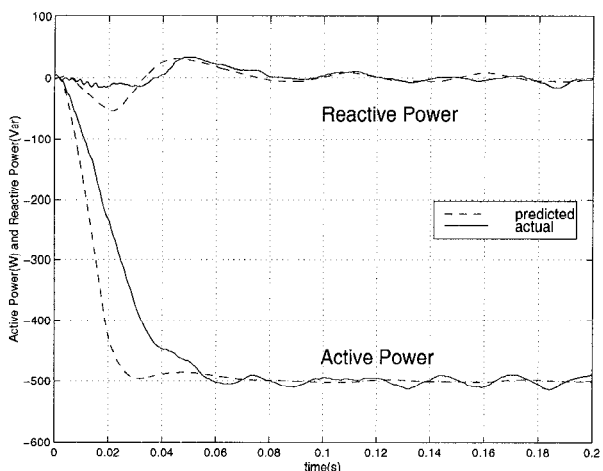

(b)

Figure 4 – Predicted and experimental response of the StatCom/BESS (a) reactive power from 0 to -500 Vars (b) active power change from 0 to -500 W

#### IV. OSCILLATION DAMPING AND VOLTAGE CONTROL

The independent control of both active and reactive power FACTS/BESS systems make them ideal controllers for many types of power system applications, including voltage control and oscillation damping. The system under consideration is shown in Figure 6 for the StatCom and StatCom/BESS and Figure 7 for the SSSC, SSSC/BESS, and the UPFC. The system data is as given in [6]. At 0.01 seconds, one of the inter-area parallel lines between buses 5 and 6 is opened. This results in a system wide drop in voltage and causes a low frequency interarea power oscillation between the two areas. The interarea oscillation exhibits a lightly-damped mode near 1.4 Hz.

For an even comparison between controllers, the same control was applied for both the FACTS and FACTS/BESS systems. The active power flow of the SSSC and UPFC was controlled using a scheme similar to the one described

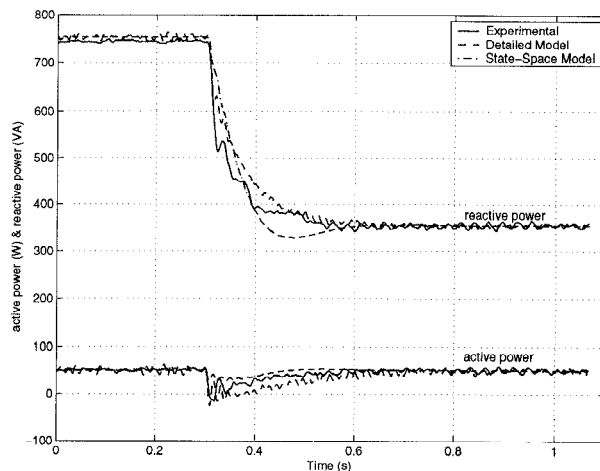

(a)

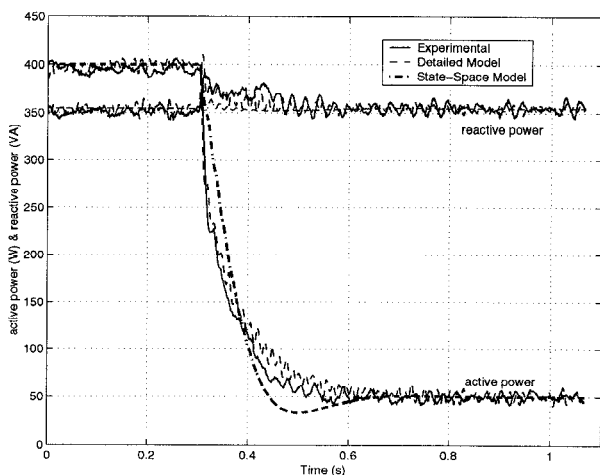

(b)

Figure 5 – Predicted and experimental response of the SSSC/BESS (a) reactive power from 755 to 50 Var; (b) active power change from 400W to 50W

in the previous system, and the StatCom as given in [2]. However, the FACTS output power is not set to a constant reference setting (as in the previous section), but rather is required to compensate for the power oscillations and the BESS is required to charge and discharge in antipathy with the line oscillations. Thus,  $P^* = P_{65} - P_{65, \text{scheduled}}$  and is a “moving target” rather than a set value.

The StatCom/BESS and the SSSC/BESS have two control signals with which to achieve the control objectives – the angle  $\alpha$  and the gain  $k$ , whereas the StatCom and the SSSC have only one control each. The UPFC has three control signals  $\alpha_1, \alpha_2$ , and  $k_2$ . Since the FACTS/BESS have two control signals, independent control of both active power and voltage is achievable, whereas both of the control objectives must be weighted in the single control in the StatCom ( $\alpha$ ) and the SSSC ( $k$ ). A comparison of the different controllers are shown in Figures 8-13.

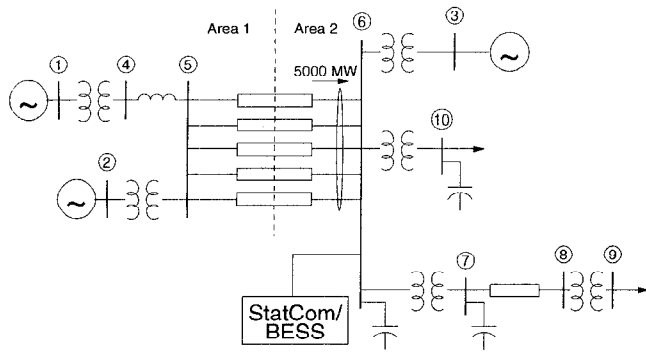

Figure 6 – Example system for StatCom/BESS

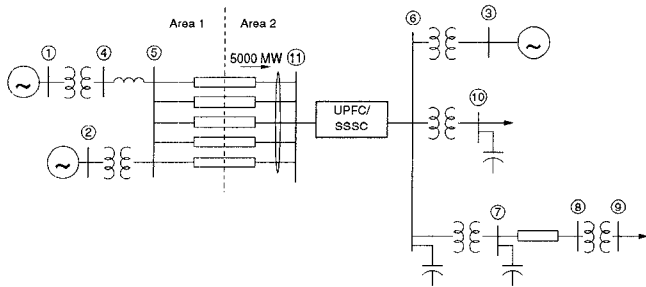

Figure 7 – Example system for SSSC/BESS

The presence of the lightly-damped oscillatory mode can be seen in the inter-area power flow waveforms in Figures 8-10. Immediately following the loss of a line, the active power flow from area 1 to area 2 drops. This sudden topology change perturbs one of the interarea oscillatory modes, resulting in a lightly-damped active power oscillation on the remaining lines. However, since the total power demand and generation in the system do not change, the power flow from area 1 to area 2 will return to the scheduled value over time. To fully mitigate the resulting oscillations, the low frequency oscillatory mode must be damped by the FACTS controllers. Note that in both power and voltage cases, the StatCom/BESS is more effective than the StatCom, and the SSSC/BESS is more effective than the SSSC. This is due to the additional degree of freedom in control and the presence of active power capabilities, especially in the oscillation damping control. Since the FACTS/BESS have two degrees of control freedom, both control objectives can be met independently, whereas the StatCom and SSSC control must be optimized to achieve both the oscillation damping and voltage control with a single input. Both the StatCom/BESS and SSSC/BESS exhibit comparable performance to the UPFC shown in Figure 10.

Figures 11-13 show the voltage at Bus 6 and the end of the parallel transmission lines. Both the StatCom and StatCom/BESS are effective in maintaining the voltage at the reference voltage setting, but the StatCom/BESS is able to achieve nearly constant voltage much more rapidly than the StatCom. The SSSC is unable to achieve the commanded voltage setting. The SSSC/BESS achieves the

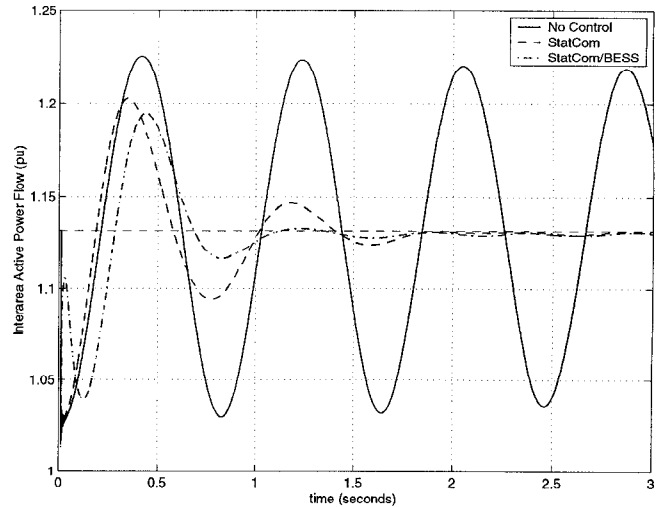

Figure 8 – Active power flow between areas (– no control, -- StatCom, -.- StatCom/BESS)

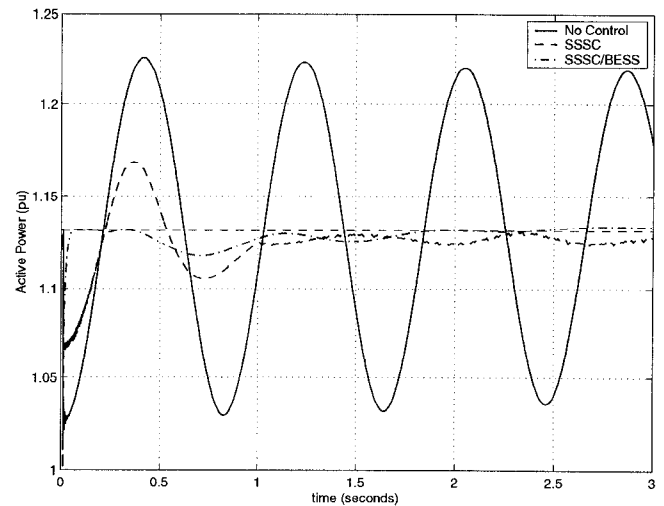

Figure 9 – Active power flow between areas (– no control, -- SSSC, -.- SSSC/BESS)

commanded voltage in roughly three seconds. The UPFC response shown in Figure 13 exhibits a large voltage excursion compared with the StatCom/BESS, but does have better performance than the SSSC/BESS.

## V. CONCLUSIONS

These results establish the viability of using FACTS/BESS to enhance bulk power system operation. Controls were proposed that have been shown via simulation and experimental verification to be effective in voltage control and oscillation damping. The FACTS/BESS exhibits increased flexibility over the traditional FACTS with improved damping capabilities due to the additional degree of control freedom provided by the active power capabilities.

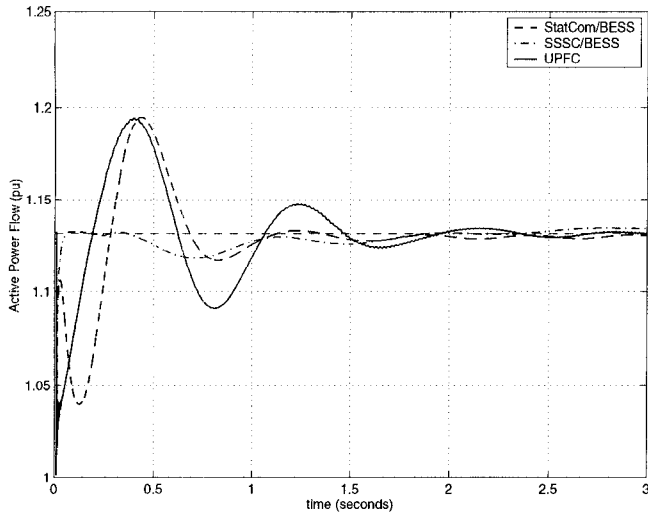

Figure 10 – Active power flow between areas (– UPFC, – – StatCom/BESS, – · – SSSC/BESS)

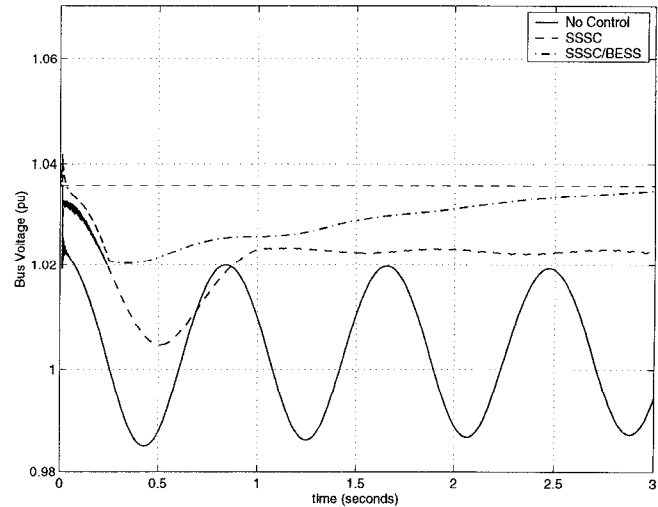

Figure 12 – Voltage at area 2 bus (– no control, – – SSSC, – · – SSSC/BESS)

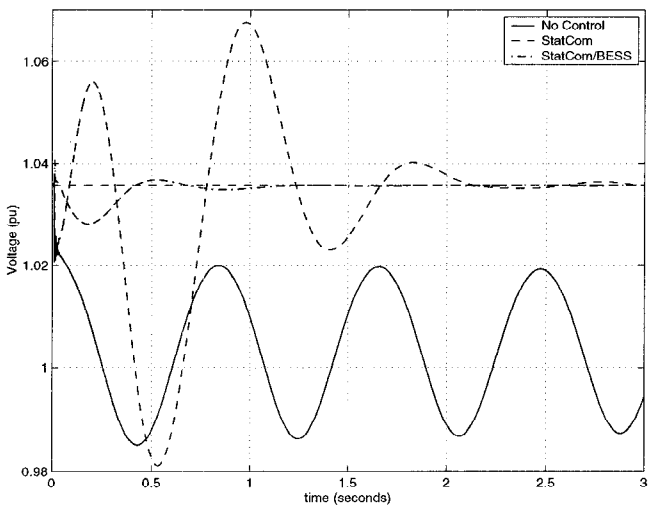

Figure 11 – Voltage at area 2 bus (– no control, – – StatCom, – · – StatCom/BESS)

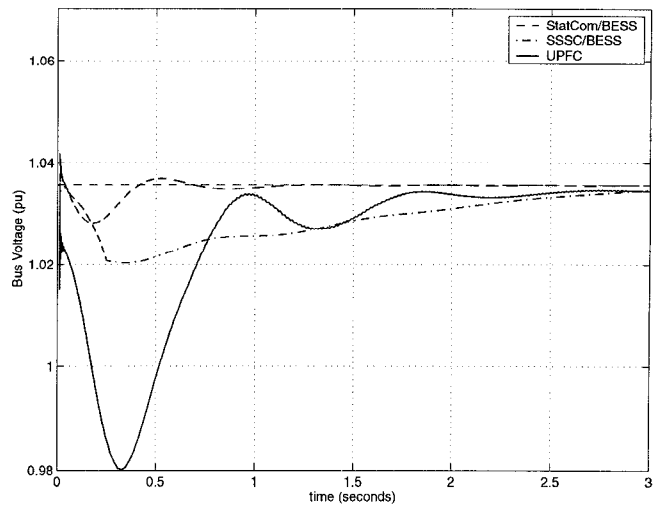

Figure 13 – Voltage at area 2 bus (– UPFC, – – StatCom/BESS, – · – SSSC/BESS)

#### ACKNOWLEDGEMENTS

The authors gratefully acknowledge the support of the National Science Foundation under grant ECS-9988868 and Sandia National Laboratories under BD-0071-D.

#### REFERENCES

- [1] S. Atcitty, S. Ranade, "Summary of State-of-the-Art PCS System Configurations and Recommendations for Future Research and Development," *Sandia Report SAND98-2019*, September 1998.
- [2] Z. Yang, C. Shen, L. Zhang, M. L. Crow, and S. Atcitty, "Integration of a StatCom and Battery Energy Storage," *IEEE Transactions on Power Systems*, to appear.
- [3] IEEE Power Engineering Society FACTS Application Task Force, *FACTS Applications*, IEEE Publications 96-TP116-0, 1996.
- [4] L. Zhang, et. al, "A PC-DSP-Based Unified Control System Design for FACTS Devices," *Proc. of the 2001 Winter Power Meeting*, Columbus, OH, January 2001.
- [5] L. Zhang, et. al, "The Steady-State Characteristics of an SSSC Integrated with Energy Storage," *Proc. of the 2001 Winter Power Meeting*, Columbus, OH, Jan 2001.
- [6] C. W. Taylor, *Power System Voltage Stability*, McGraw-Hill, New York, 1994.