

8-1-2004

A Circuit Approach to Model Narrow Slot Structures in a Power Bus

Lin Zhang

Ray Alexander

Richard E. DuBroff

Missouri University of Science and Technology, red@mst.edu

James L. Drewniak

Missouri University of Science and Technology, drewniak@mst.edu

et. al. For a complete list of authors, see http://scholarsmine.mst.edu/ele_comeng_facwork/1336

Follow this and additional works at: http://scholarsmine.mst.edu/ele_comeng_facwork



Part of the [Electrical and Computer Engineering Commons](#)

Recommended Citation

L. Zhang et al., "A Circuit Approach to Model Narrow Slot Structures in a Power Bus," *Proceedings of the IEEE International Symposium on Electromagnetic Compatibility (2004, Santa Clara, CA)*, pp. 401-406, Institute of Electrical and Electronics Engineers (IEEE), Aug 2004.

The definitive version is available at <http://dx.doi.org/10.1109/ISEMC.2004.1349825>

This Article - Conference proceedings is brought to you for free and open access by Scholars' Mine. It has been accepted for inclusion in Electrical and Computer Engineering Faculty Research & Creative Works by an authorized administrator of Scholars' Mine. This work is protected by U. S. Copyright Law. Unauthorized use including reproduction for redistribution requires the permission of the copyright holder. For more information, please contact scholarsmine@mst.edu.

A Circuit Approach to Model Narrow Slot Structures in a Power Bus

Lin Zhang, Bruce Archambeault*, Samuel Conner*, James L. Knighten**, Jun Fan**, Norman W. Smith**, Ray Alexander**, Richard E. DuBroff and James L. Drewniak

EMC Laboratory
Dept. Electrical Engineering
University of Missouri, Rolla, MO
65401
lzhang@ece.UMR.edu

* IBM
P. O. Box 12195
3039 Cornwallis Rd.
Dept 18DA, B306
RTP, NC 27709

**NCR Corporation
17095 Via del Campo
San Diego, CA 92127

Abstract

In this paper, a coupled transmission line model for narrow slot structures in DC power planes is proposed. This approach combined with SPICE-based cavity models and a segmentation method provides an easy and fast way to model relatively complex structures of power planes with narrow slots often used for isolation purposes. This approach will be used to achieve isolation using gapping. The cavity model formulations for rectangular and isosceles right triangular segments are reviewed in Sec II. In Sec III, the rationale of modeling the narrow slot as a three-conductor transmission lines are described. In Sec IV, the modeling results are shown and compared with the output of a full wave simulation tool, HFSS, and experimental measurements.

Keywords

SPICE, circuit, cavity model, coupled microstrip, transmission line, HyperLynx

I. INTRODUCTION

DC power bus noise due to digital logic switching and layer transitions of digital integrated circuits (ICs) is a crucial topic in power integrity [1]. The isolation technique using power plane segmentation and power islands is an effective method for alleviating power bus noise. Another approach is to use decoupling capacitors to solve these problems [2]. Good isolation can be obtained over a wide frequency band due to the large series impedance provided by the gap between the power islands [3]. Some full wave simulation approaches such as CEMPIE and hybrid FEM/MOM were implemented to anticipate the power bus noise from gapped power plane structures up to gigahertz frequencies [4], [5]. A fast algorithm based on the cavity resonator model was also applied to investigate the gapped power plane case [6].

The noise voltage induced in the power bus pair is correlated to the self-impedance or transfer-impedance of the power bus. Thus, predicting the self-impedance or transfer-impedance of the power plane pair is a key step to anticipate the characteristics of the power bus. The cavity model

method proposed in [6] used lumped elements such as R , L and C to represent the coupling model across the isolating gap. This paper will present a three-conductor transmission line model to represent the coupling mode over the isolating gaps. Combined with the circuit representation of the cavity resonators for rectangular and triangular segments [7], this approach can predict both the time and frequency domain information for arbitrarily shaped power planes with isolation gaps and slits.

In Section 2 of this paper, the circuit cavity models for rectangular and isosceles right triangular patches are described. The rationale of applying the transmission line model to represent the coupling model over the slots is explained using HyperLynx in Section 3. Using this approach, a structure with a narrow slot is modeled and compared with a full wave simulation tool and with experimental measurements. This approach will provide signal integrity engineers a fast and easy method to anticipate the characteristics of power plane geometries with a power isolation structure.

II. THE CIRCUIT MODELS FOR RECTANGULAR AND TRIANGULAR POWER PLANE SEGMENTS

The lumped circuit model shown in Figure 1 applies to both rectangular and isosceles right triangular patches given appropriate choices for the circuit parameters. In both cases the transfer impedance between two ports is in the form of (1). Circuit parameters are given in (2) and (3) for rectangular and isosceles right triangular patches. In these equations, a and b are the dimensions shown in Figure 2, and d is the distance from the power plane to the ground plane, while ω is the angular frequency and m and n are mode indices.

$$Z_{ij}(\omega) = \sum_{n=0}^{\infty} \sum_{m=0}^{\infty} \frac{N_{nm} N_{nmj}}{j\omega L_{nm} + j\omega C_{nm} + G_{nm}} \quad (1)$$

$$\omega_{mn} = \frac{1}{\sqrt{\mu\epsilon}} \sqrt{\left(\frac{m\pi}{a}\right)^2 + \left(\frac{n\pi}{b}\right)^2}$$

$$L_{mn} = d / (\omega_{mn} ab\epsilon)$$

$$C_{mn} = ab\epsilon / d$$

$$G_{mn} = (ab\epsilon / d) \omega_{mn} (\tan \delta + r / d) \quad (2)$$

$$r = \sqrt{\frac{1}{\pi f \mu \sigma}}$$

$$N_{mni} = \epsilon_n \epsilon_m \cos(m\pi x_i / a) \cos(n\pi y_i / b)$$

$$\text{sinc}(m\pi W_{xi} / 2a) \text{sinc}(n\pi W_{yi} / 2b)$$

$$L_{mn} = \frac{d}{2\omega_{mn}^2 a^2 \epsilon}$$

$$C_{mn} = \frac{2\epsilon a^2}{d} \quad (3)$$

$$G_{mn} = (2a^2 \epsilon / d) \omega_{mn} (\tan \delta + \sqrt{2 / (\omega_{mn} \mu \sigma)} / d)$$

$$N_{mni} = e_n e_m [\cos(k_x x_i) \cos(k_y y_i) \text{sinc}(k_x W_x / 2) \text{sinc}(k_y W_y / 2)$$

$$+ (-1)^{m+n} \cos(k_x x_i) \cos(k_y y_i) \text{sinc}(k_x W_x / 2) \text{sinc}(k_y W_y / 2)]$$

For power planes containing a narrow slot, as shown in Figure 3(a), the segmentation method [9] is implemented to divide the power planes into several rectangular segments. For each segment the cavity model solution (Figure 1) can provide a local impedance matrix. The segmentation method is then implemented to assemble all the local matrices into a global matrix. Integrating the coupled transmission line representation for the slot with the global matrix yields the overall matrix containing the impedance elements of the structure (e.g. the self and transfer impedances). In the following section, the rationale of applying the transmission line model will be explained.

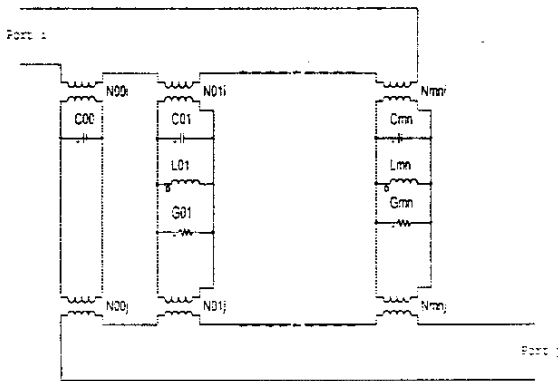

Figure 1. The circuit model for rectangular and isosceles triangular power planes.

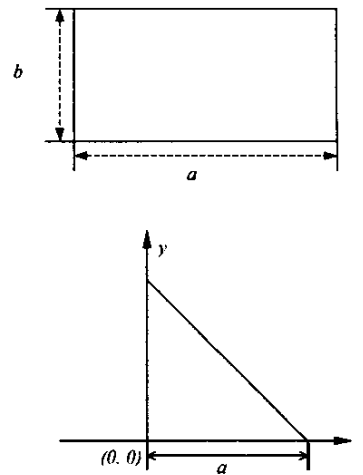
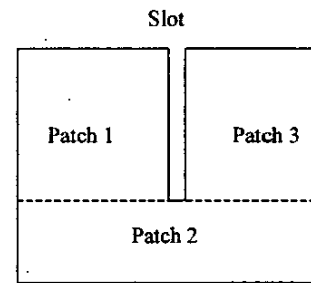
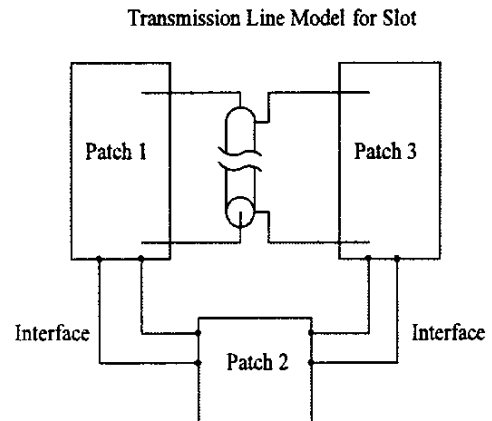

Figure 2. Basic patches of rectangular and isosceles right triangular shape.



(a)



(b)

Figure 3. Circuit model for power planes with a narrow slot:

- (a) Two-layer power planes,
- (b) Transmission line model for slot line, and the segmentation configuration.

III. TRANSMISSION LINE MODEL FOR SLOT STRUCTURE IN POWER PLANES

HyperLynx was used to examine the rationale of this approach. Figure 4 and Figure 5 show the differential and common mode fields for a pair of two-layer planes with a narrow gap. Figure 6 and Figure 7 shows the same fields for a three-conductor transmission line. From these two cases it is reasonable and feasible to treat the edge or fringe effects of the narrow slot in power planes as a coupled three-conductor transmission line model. Applying the segmentation method to connect the transmission line network and the cavity model network together should yield the overall properties of this type of structure.

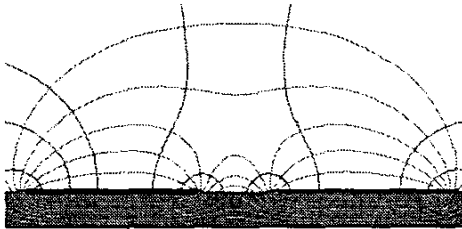

Figure 4. Common mode for a narrow slot line case.

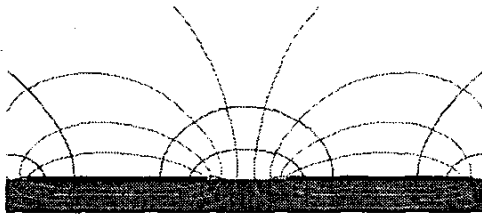

Figure 5. Differential mode for a narrow slot line case.

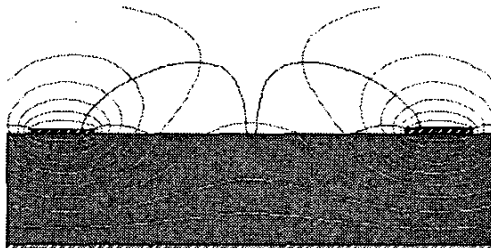

Figure 6. Common mode for a three-conductor transmission line structure.

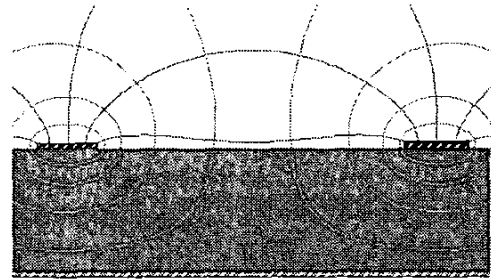

Figure 7. Differential mode for a three-conductor transmission line structure.

IV. SIMULATION AND MEASUREMENT RESULTS

An example of a power plane pair in which one plane contains a slot is shown in Figure 8. Figure 9 shows how the slotted plane is divided into two fundamentally different pieces. One piece is modeled as before [7] through the use of a segmented cavity model. The other piece is modeled as a coupled three-conductor transmission line. Continuity of voltage and current between these two pieces is enforced by the use of segmentation ports as shown in the figure. The segmented cavity model, the transmission line model, and the segmentation ports connecting these two regions can all be modeled in HSPICE.

The example shown in Figure 8 can also be modeled using full wave simulation methods, such as HFSS (High Frequency Structure Simulator by Ansoft). Figure 10 shows a comparison between three of these simulation methods. The first curve, labeled cavity with TXL, is an HSPICE simulation of the input impedance at Port 1 for a combination of a segmented cavity model and a coupled transmission line model, as shown in Figure 9. The second curve, labeled cavity only, results from an HSPICE simulation of the segmented cavity model without the transmission line model. The third curve, labeled HFSS, shows the results of a full wave simulation. Figure 11 shows a comparison of the transfer impedances between ports 1 and 2.

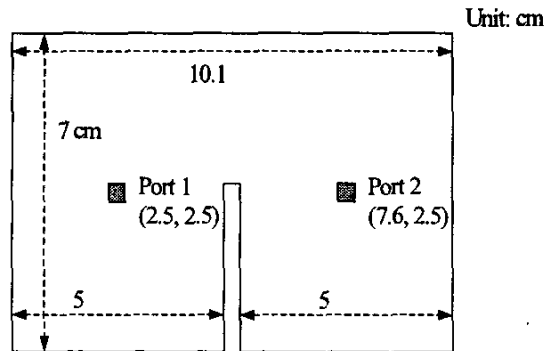

Figure 8. A narrow gap structure in the power bus.

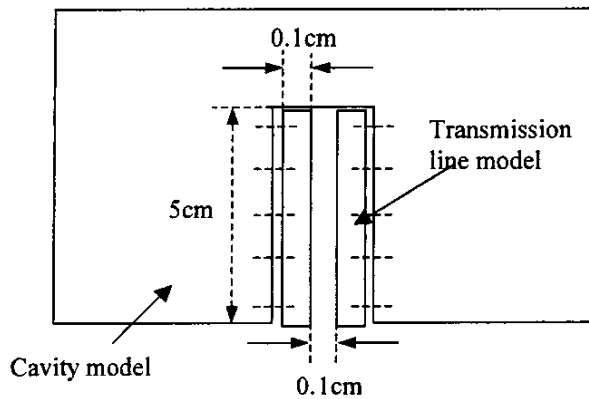

Figure 9. Separation of the slotted power planes into a cavity model combined with a transmission line model.

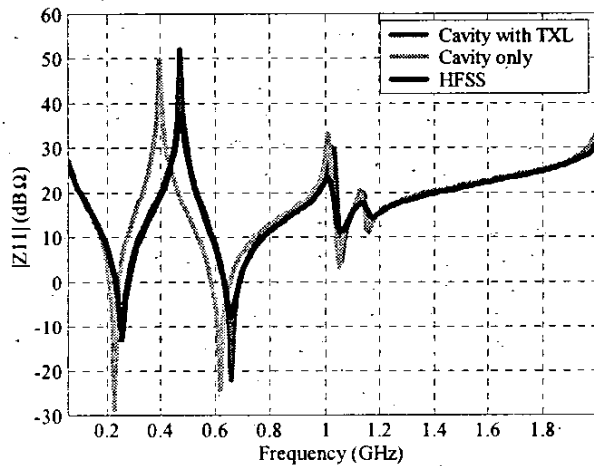

Figure 10. Comparison of $|Z_{11}|$ from the cavity-transmission line model, the cavity only model, and HFSS.

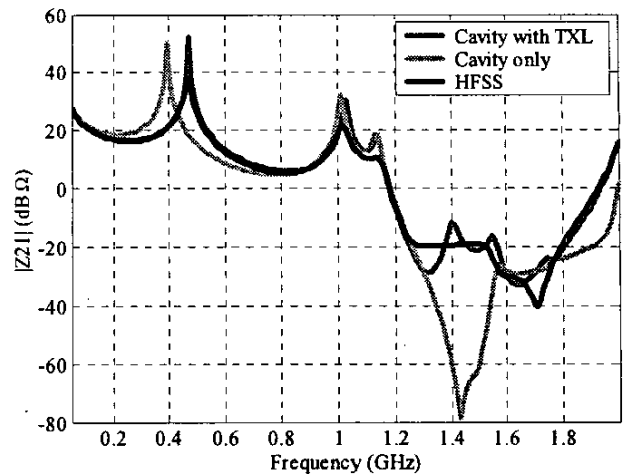

Figure 11. Comparison of $|Z_{21}|$ from the cavity-transmission line model, the cavity only model, and HFSS.

A test board was built to validate this approach. The board is shown in Figure 12. The width of the slot is 0.1 cm. The measured and simulated self impedances at port 1 are compared in Figure 13. The magnitudes of S_{21} are compared in Figure 14 and the phase information for S_{21} is displayed in Figure 15.

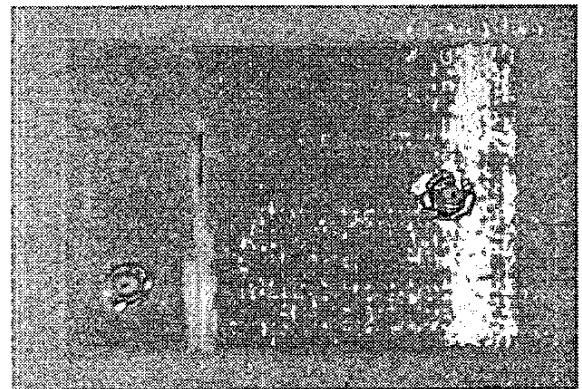

Figure 12. The experimental test board.

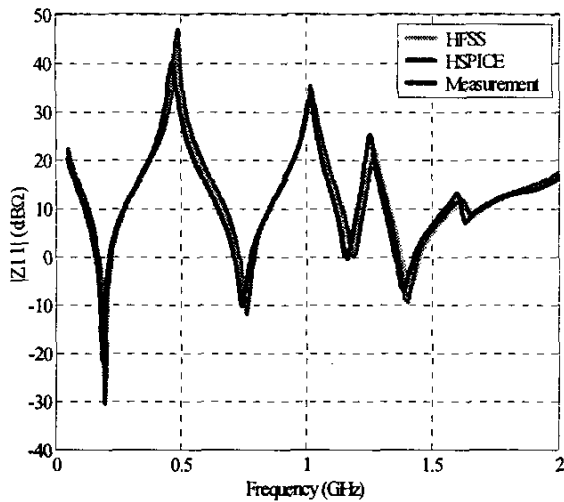

Figure 13. Simulation results compared with experimental measurements for the test board in Figure 12.

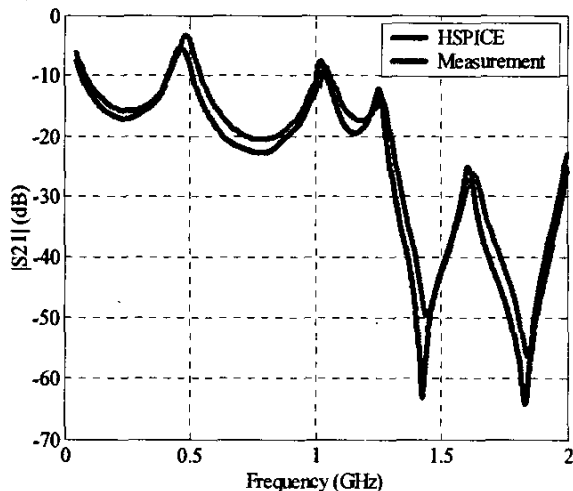

Figure 14. $|S_{21}|$ results by HSPICE and the experiment measurements for the test board in Figure 12.

V. CONCLUSIONS

An innovative approach to estimate the impedance of the power planes with narrow slot lines is proposed. This approach combines the cavity model with transmission line theory. Incorporating the transmission line model into the cavity model generally improves the agreement with full wave simulation. This is shown in Figure 10, for example, where the input impedance peaks and minima, particularly between 0.2 and 0.8 GHz, track the HFSS results better when the transmission line model is included (Cavity with TXL). The match between HFSS results and the combined model is also somewhat better than the match between

HFSS and the cavity only model in Figure 11. As a further test of this method, a test board was built thereby allowing the predictions of this approach to be compared with experimentally measured results. Again the magnitude of the input impedance and the magnitude and phase of the S_{21} parameter generally seem to match well with experimental measurements with the largest discrepancies occurring at the frequencies where S_{21} has a sharp minimum—around 1.4 GHz and around 1.8 GHz. Ultimately, it is intended to use this approach for estimating power bus noise in the presence of isolation structures in high-speed digital design.

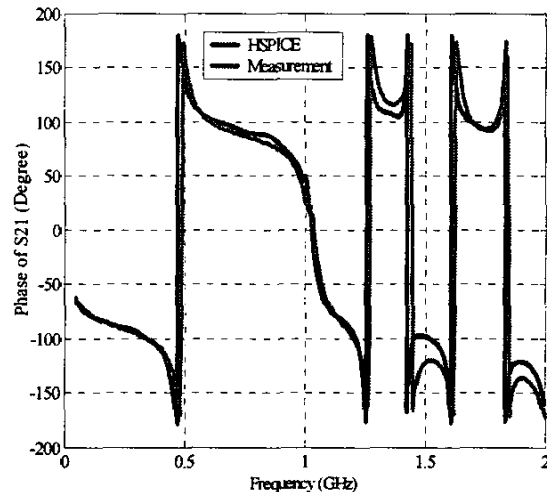

Figure 15. Comparison of phase of S_{21} for the test board in Figure 12.

REFERENCES

- [1] H. W. Johnson and M. Graham, "High Speed Digital Design: A Handbook of Black Magic", Englewood Cliffs, NJ, Prentice Hall, 1993.
- [2] Wei Cui, Jun Fan, Yong Ren, Hao Shi, James L. Drewniak and Richard E. DuBroff, "DC Power Bus Noise Isolation With Power Plane Segmentation", *IEEE Transaction on Electromagnetic Compatibility*, Vol. 45, No. 2, May 2003, pp. 436 – 443.
- [3] Juan Chen, Todd H. Hubing, Thomas P. Van Doren, and Richard E. DuBroff, "Power Bus Isolation Using Power Islands in Printed Circuit Boards", *IEEE Transactions on Electromagnetic Compatibility*, Vol. 44, No. 2, May 2002, pp. 373 – 380.
- [4] Yun Ji, and Todd H. Hubing, "On the modeling of a Gapped Power Bus structure Using a Hybrid FEM/MOM Approach", *IEEE Transactions on Electromagnetic Compatibility*, Vol. 44, No. 4, November 2002, pp. 566 – 569.
- [5] Jun Fan, James L. Drewniak, Hao Shi, and James L. Knighten, "DC Power Bus Modeling and Design with

- a Mixed-Potential Integral Equation Formulation and Circuit Extraction”, *IEEE Transactions on Electromagnetic Compatibility*, Vol. 43, No. 4, November 2001, pp. 426 – 436.
- [6] Zhi Liang Wang, Osami Wada, and Ryuji Koga, “Modeling of Gapped Power Bus Structures for Isolation Using Cavity Modes”, in *Proc. IEEE International Symposium Electromagnetic Compatibility*, Boston, MA, August 2003, pp. 10 – 15.
- [7] Lin Zhang, et. al., “A Cavity Model Approach to The Development of Impedance Formulations For Triangular Patches”, to be submitted.
- [8] Lin Zhang, et. al., “A Time Domain Approach To Anticipate Characteristics of Arbitrarily Shaped Power Planes”, to be submitted.
- [9] T. Okoshi, Y. Uehara, and T. Takeuchi, “The Segmentation Method – An Approach to the Analysis of Microwave Planar Circuits”, *IEEE Trans. on Microwave Theory and Techniques*, Oct 1976, pp. 662 – 668.