

2006

A Comparison of Diode-Clamped and Cascaded Multilevel Converters for a STATCOM with Energy Storage

Ying Cheng

Chang Qian

Mariesa Crow

Missouri University of Science and Technology, crow@mst.edu

Steven Pekarek

Missouri University of Science and Technology

et. al. For a complete list of authors, see http://scholarsmine.mst.edu/ele_comeng_facwork/768

Follow this and additional works at: http://scholarsmine.mst.edu/ele_comeng_facwork



Part of the [Electrical and Computer Engineering Commons](#)

Recommended Citation

Y. Cheng et al., "A Comparison of Diode-Clamped and Cascaded Multilevel Converters for a STATCOM with Energy Storage," *IEEE Transactions on Industrial Electronics*, vol. 53, no. 5, pp. 1512-1521, Institute of Electrical and Electronics Engineers (IEEE), Jan 2006. The definitive version is available at <http://dx.doi.org/10.1109/TIE.2006.882022>

This Article - Journal is brought to you for free and open access by Scholars' Mine. It has been accepted for inclusion in Electrical and Computer Engineering Faculty Research & Creative Works by an authorized administrator of Scholars' Mine. This work is protected by U. S. Copyright Law. Unauthorized use including reproduction for redistribution requires the permission of the copyright holder. For more information, please contact scholarsmine@mst.edu.

A Comparison of Diode-Clamped and Cascaded Multilevel Converters for a STATCOM With Energy Storage

Ying Cheng, *Member, IEEE*, Chang Qian, *Member, IEEE*, Mariesa L. Crow, *Senior Member, IEEE*, Steve Pekarek, *Member, IEEE*, and Stan Atcitty, *Associate Member, IEEE*

Abstract—The progression of distributed generation within a bulk power system will lead to the need for greater control of transmission-line power flows. Static synchronous compensators (STATCOMs) provide a power-electronics-based means of embedded control of transmission-line voltage and power flows. The integration of energy storage with a STATCOM can extend traditional STATCOM capabilities to four-quadrant power flow control and transient stability improvement. This paper discusses energy storage systems (ESSs) integrated with conventional and multilevel bidirectional power converters for a hybrid STATCOM/ESS. Conventional, diode-clamped, and cascaded multilevel converter-based STATCOM/ESSs are developed, and their performances for a variety of power system applications are compared using battery energy storage. The advantages and disadvantages of each topology are presented. Both simulation and experimental results are provided to validate the conclusions.

Index Terms—Battery energy storage (BESS), multilevel converters, static synchronous compensators (STATCOMs).

I. INTRODUCTION

As distributed-generation systems evolve, traditional vertically integrated utility structures will be phased out. As this occurs, centralized control of bulk-power systems will no longer be possible. Transmission providers will be forced to seek means of local control to address a number of potential problems, such as uneven power flow through the system (loop flows), transient and dynamic instability, subsynchronous oscillations, and overvoltages and undervoltages. Flexible ac transmission system (FACTS) power-electronics-based controllers can potentially provide a solution to these potential problems

Manuscript received December 10, 2004; revised May 30, 2005. Abstract published on the Internet July 14, 2006. This work was supported by the DOE Energy Storage Program through Sandia National Laboratories under Contract BD-0071-D. Sandia is a multiprogram laboratory operated by Sandia Corporation, a Lockheed Martin Company, for the U.S. Department of Energy's National Nuclear Security Administration under Contract DE-AC04-94AL85000.

Y. Cheng is with the Department of Electrical and Computer Engineering, University of Missouri, Rolla, MO 65409-0040 USA.

C. Qian was with the Department of Electrical and Computer Engineering, University of Missouri, Rolla, MO 65409-0040 USA. He is now with International Rectifier, El Segundo, CA 90245 USA.

M. L. Crow is with the School of Materials, Energy, and Earth Resources and the Department of Electrical and Computer Engineering, University of Missouri, Rolla, MO 65409-0040 USA (e-mail: crow@umr.edu).

S. Pekarek is with Purdue University, West Lafayette, IN 47907 USA.

S. Atcitty is with Sandia National Laboratories, Albuquerque, NM 87185 USA (e-mail: satcitt@sandia.gov).

Digital Object Identifier 10.1109/TIE.2006.882022

and represent a key technology for the next generation of power systems.

In recent years, several FACTS topologies have been proposed to solve problems in existing power networks [1]. The majority of these topologies are designed to mitigate problems by controlling the reactive power through a transmission/distribution line. The integration of energy storage systems (ESSs) into FACTS devices will be required in future generation power systems since the problems of uneven active-power flow, transient and dynamic stability, subsynchronous oscillations, and power quality issues are impacted more effectively through active-power control. Since the power-conversion systems required for ESS are similar to the power-electronics topologies of traditional FACTS devices, combined FACTS/ESS can be designed to have comparable cost and provide better performance than separate stand-alone ESS or FACTS devices [2]–[7].

One drawback to FACTS/ESS, however, is that the size of the storage systems for FACTS integration, particularly battery energy storage (BESS), may be too high for practical use in transmission-level applications. Large battery systems tend to exhibit voltage instability when numerous cells are placed in series. Recent studies, however, have shown that even large oscillations can be mitigated with modest power injection from a storage system [8]; therefore, it is feasible to consider designs for FACTS converters that take advantage of smaller lower voltage energy systems. One approach to decreasing the required BESS voltage is to replace the standard converter with a multilevel inverter. Multilevel-converter-based FACTSs offer improved voltage quality, decreased switching frequencies, reduced power losses, and decreased stress on individual power-electronics devices. In addition, multilevel-converter-based FACTSs enable more effective use of ESSs. Several multilevel power-electronics topologies have been proposed for FACTS devices [9]–[11].

Individually, the benefits of integrating energy storage and static synchronous compensators (STATCOMs), and STATCOM power electronics topologies have been documented. However, an investigation of the suitability of individual topologies for STATCOM/energy storage has not yet been documented. In this paper, the cascaded and diode-clamped multilevel STATCOMs are considered for a STATCOM with BESS. The steady-state and dynamic responses of the two inverters are compared with those of a traditional six-pulse

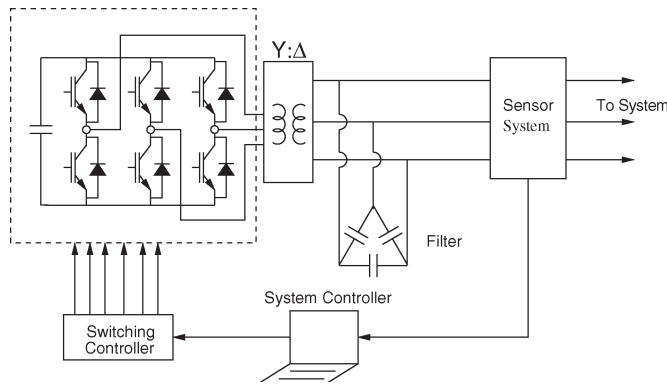

Fig. 1. Schematic of the traditional six-pulse STATCOM.

inverter. Using a design constraint that there is a fixed number of batteries, it is shown that cascaded and diode-clamped multilevel converters provide superior performance to the traditional STATCOM. The advantages and disadvantages of each multilevel topology for BESS applications are summarized. Simulation and experimental results are provided to validate all claims. It is noted that although the results are shown for a BESS, they may can be generalized to most distributed-energy systems, including superconducting magnetic energy storage (SMES) and fuel cells.

II. BACKGROUND: TRADITIONAL STATCOM/ESS

A schematic of a traditional six-pulse STATCOM is shown in Fig. 1. The STATCOM is a shunt-connected FACTS device that is used primarily for reactive-power control. The traditional STATCOM (with no energy storage) has only two possible steady-state operating modes: inductive (lagging) and capacitive (leading). Although both the STATCOM output-voltage magnitude and phase angle can be controlled, they cannot be independently adjusted since the STATCOM has no active-power capability. Thus, it is impossible to significantly impact both active P and reactive Q powers simultaneously. STATCOMs have been widely accepted to improve power system operation. In bulk-power systems, they are used to stabilize the power system and maintain bus voltage. A STATCOM without accompanying energy storage is used primarily for reactive power support [1]. Of the potential problems affecting transmission-system operation, only voltage-related problems can be significantly mitigated by STATCOM-controlled reactive-power injection. The problems of uneven active-power flow, transient and dynamic stability, subsynchronous oscillations, and power quality issues can be impacted more effectively by active-power control. Integrating an ESS, such as batteries, fuel cells, SMES, or flywheels, into a STATCOM device can provide dynamic decentralized active-power capabilities and give transmission service providers much needed flexibility for mitigating transmission-level power flow problems.

The control of STATCOM/ESS is much simpler than that of the STATCOM alone. To be effective in mitigating system-level disturbances, the dc voltage of the STATCOM must be closely regulated. However, if an ESS, such as a battery, is connected in parallel to the dc capacitor, the battery will naturally maintain the dc-capacitor voltage within a small operating range. Since

the dc voltage no longer requires direct control, it is possible to design controls to vary the output reactive power (or voltage) and active power independently by adjusting the magnitude and angle of the fundamental component of the injected current.

III. MULTILEVEL STATCOM/ESS CONVERTER

There are several compelling reasons to consider a multilevel-converter topology for the STATCOM/ESS. These well-known reasons include lower harmonic injection into the power system, decreased stress on the electronic components due to decreased voltages, and lower switching losses. Various multilevel converters also readily lend themselves to a variety of pulsewidth-modulation (PWM) strategies to improve efficiency and control. In the case of the STATCOM with batteries as the ESS (STATCOM/BESS), the primary reason to consider a multilevel converter is to decrease the size of the batteries. As battery size increases, the footprint, weight, and maintenance requirements of the BESS become unwieldy. The large series combination of battery cells required to reach high voltages often leads to charge and discharge instability [2]. There are similar disadvantages in large fuel cells, SMES, and flywheel units. The use of multilevel converters can readily reduce the size of the individual energy storage units without compromising performance. One additional advantage of incorporating energy storage and the STATCOM is that the converter dc-link capacitor can be significantly decreased because only a small capacitor is required to smooth the dc current seen by the battery. In this paper, two multilevel converters, the cascaded and the diode-clamped converters, are compared and contrasted to ascertain the advantages and disadvantages of each topology for a STATCOM/BESS.

A. Cascaded STATCOM/ESS

A cascaded multilevel FACTS converter is shown in Fig. 2. This converter uses several full bridges in series to synthesize staircase waveforms. Because every full bridge can have three output voltages with different switching combinations, the number of output-voltage levels is $2N + 1$, where N is the number of full bridges in every phase. The converter legs are identical and therefore modular.

The cascaded converter has several attractive features. One such feature is that the cascaded converter can be easily controlled to mitigate the charge-balancing problems that plague many multilevel-converter topologies. A charge imbalance originates from the uneven charging and discharging of multiple dc sources at different voltage levels, causing a voltage imbalance. A dc voltage imbalance will degrade the quality of the voltage output; in severe cases, this could lead to the complete collapse of the power-conversion system. The output voltage is a staircase waveform synthesized by alternating the contributions of multiple H-bridges at each half-cycle. Because during each half-cycle, the conduction time for each battery is different, the batteries will have different charge and discharge intervals. In the cascaded converter, the imbalance can be mitigated by introducing a rotated switching scheme in which the conduction period of each battery is interchanged with the adjacent batteries in the subsequent half-cycle [11]. Therefore,

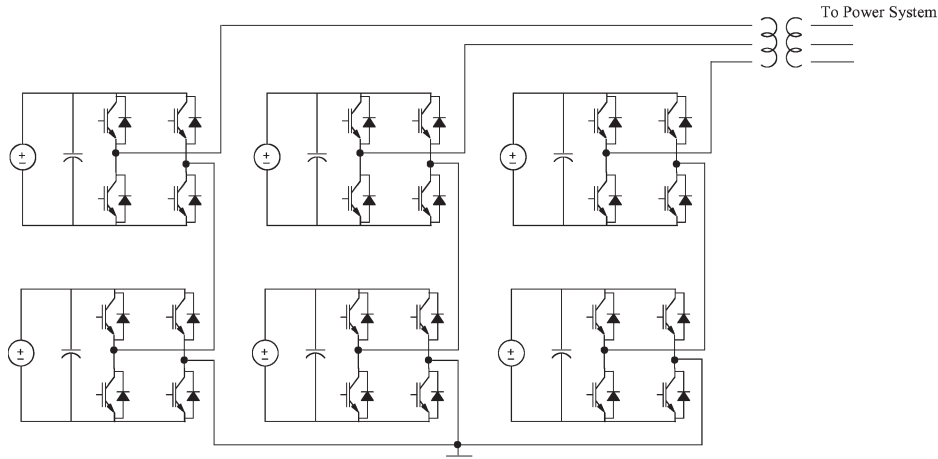

Fig. 2. Cascaded STATCOM/BESS schematic.

TABLE I
NINE-LEVEL VERSUS FIVE-LEVEL CONVERTERS

Nine Level $V_1 > V_2$	Five Level $V_1 = V_2 = V$
$V_1 + V_2$	$2V$
V_1	V
V_2	V
$V_1 - V_2$	0
0	0
$V_2 - V_1$	0
$-V_2$	$-V$
$-V_1$	$-V$
$-V_1 - V_2$	$-2V$

each battery will have the same charge and discharge period over the complete cycle, thus balancing the voltage.

The cascaded converter also has an attractive feature, i.e., it can be reconfigured to exploit the modularity of the converter topology. A five-level cascaded converter with unequal voltage levels can be converted into a nine-level converter [13]. For example, if the batteries of the five-level converter are rearranged such that dc voltages V_1 and V_2 are unequal, then a nine-level staircase output-voltage waveform can be synthesized. By careful selection of the battery voltages, the nine-level converter can provide superior harmonic performance. A comparison of the five-level output waveform to a nine-level waveform is shown in Table I. The corresponding nine-level output waveform for $V_1 = 0.6$ V and $V_2 = 0.4$ V is shown in Fig. 3.

The primary drawback to the cascaded topology is that each leg requires an isolated voltage source for active-power conversion. Due to the strict requirement that each dc source must be electrically isolated, a larger number of batteries is required to synthesize the same ac system output-voltage level as the traditional STATCOM or a transformer must be utilized to step up the voltage to the ac system level.

B. Diode-Clamped STATCOM/ESS

The diode clamped multilevel converter shown in Fig. 4 uses a series string of capacitors to divide the dc side voltage into several levels. Normally an N -level diode-clamped multilevel inverter has $2(N - 1)$ main switches and $2(N - 1)$ main

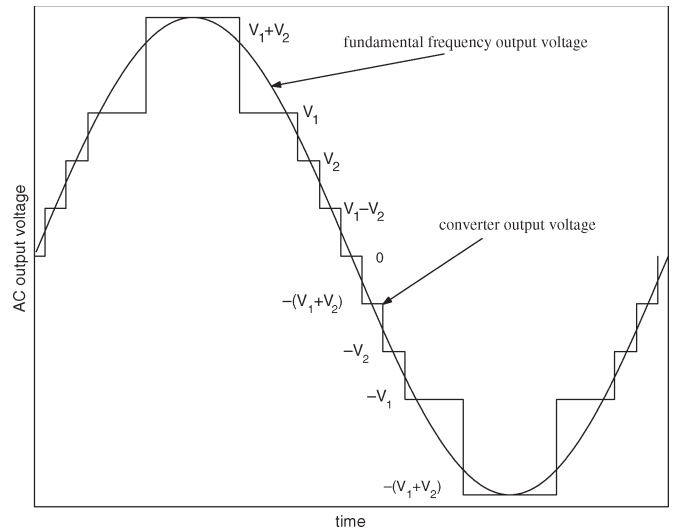

Fig. 3. Nine-level waveform constructed from a five-level cascaded converter with $V_1 = 0.6$ V and $V_2 = 0.4$ V.

diodes per phase. The switches of each phase leg are connected via power diodes to the different voltage level points set by the dc capacitors. When operating, two adjacent switches (for a three-level converter) in each phase leg are ON to provide a respective voltage level; therefore, the line voltage waveforms are synthesized by different combinations of switches.

Diode-clamped converters are used less frequently in industrial applications than cascaded converters due to the potential for charge imbalance of the capacitors. However, recent advances in charge-balancing methods have made the diode-clamped converter more attractive [14]–[17]. The two most common approaches for charge balancing are to introduce an external balancing circuit or to use space-vector modulation [15], [16].

Surprisingly, the external balancing circuit is an attractive feature for the STATCOM/BESS. Since a balancing circuit is required for optimal operation, several connections can be used to better utilize the STATCOM/BESS. For example, the number of batteries can be reduced by placing them across the inner dc-link capacitors. This reduced system is called a STATCOM/2BESS, whereas the STATCOM/4BESS has a

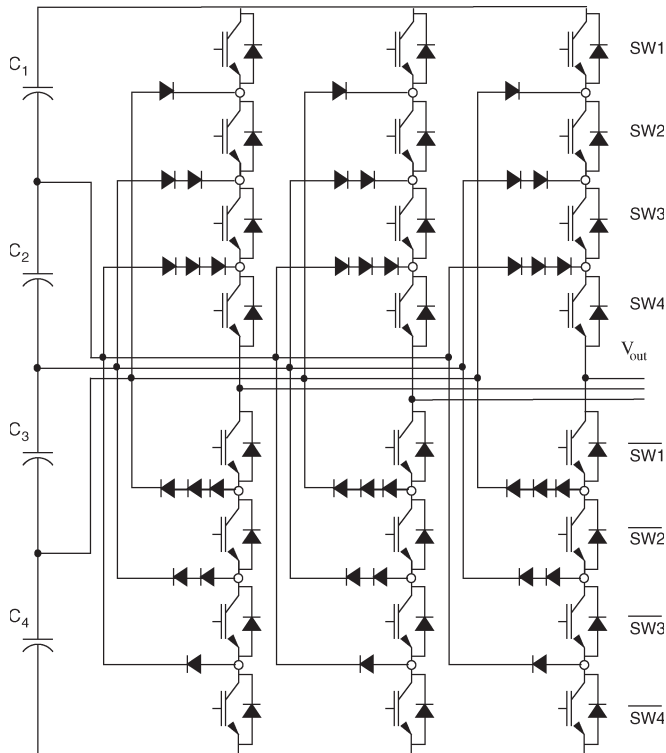

Fig. 4. Diode-clamped STATCOM schematic.

battery across each capacitor. The external balancing circuit shown in Fig. 5 will automatically balance the active- and reactive-power outputs of the dc sources, therefore providing comparable performance to a full STATCOM/BESS under moderate operating conditions. Normally, the voltage of the two outer capacitors will vary dramatically due to the active-power exchange between the system and the dc side. With proper balancing circuit control, the energy can be distributed among the batteries, inductors, and dc capacitors. There is a tradeoff between the response time and the current through the batteries. If the inductor is small, the time constant is small, and the energy exchange is fast. However, the current drawn from the batteries may exceed the battery physical-current limitation. On the other hand, if the inductor is large, the current will be small and will therefore take longer to balance the outer-capacitor voltage.

Since the diode-clamped topology has the advantage of switching redundancies, another approach to charge balancing is to use space-vector modulation. For the five-level inverter, there are $5^3 = 125$ possible switching states. These 125 switching states have 61 different output line-line voltages. The remaining switching states are redundant states. As a result of these redundancies, space-vector modulation has the inherent capability to balance the dc voltages without additional external balancing circuits.

The primary disadvantage of the diode-clamped topology over the cascaded topology is switching control complexity, increase in switching losses, and increase in cost due to the number of devices. The increase in the cost of components however may be offset by the required transformer or extra batteries of the cascaded topology.

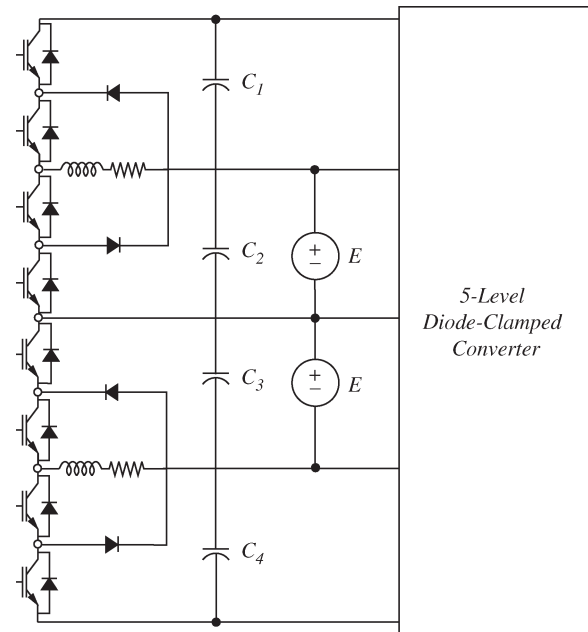

Fig. 5. Balancing circuit for five-level diode-clamped STATCOM/2 BESS converter.

IV. TOPOLOGY COMPARISONS

To provide as even a comparison as possible between topologies, the three STATCOM/BESS controllers have been designed to have the same number of batteries and PWM base switching frequencies. The cascaded STATCOM/BESS utilizes 36 batteries in six strings of six 12-V batteries, with each string at 72 Vdc. The diode-clamped STATCOM/BESS utilizes 36 batteries in four strings of nine batteries, with each string at 108 Vdc. The traditional STATCOM/BESS utilizes 36 batteries in one string of 36 batteries, with each string at 432 Vdc. Each battery string has a current limit of 17 A.

Each STATCOM was interfaced with a battery set that consists of 36 Trojan VLRA super-gel batteries. A data acquisition system was constructed to monitor the battery voltages and string currents. A signal interface board converts the current signals into voltage signals and filters the high-frequency noise. A bank of three-phase 230- μ F capacitors is used to filter the line-line STATCOM/BESS voltage output. The monitoring and control system for the integrated STATCOM/BESS system consists of two M5000 boards: one for data acquisition and preprocessing and the other for PWM signal generation. The A/D board measures the system frequency within 0.01 Hz. It is also used to calculate various state variables such as P , Q , V_{rms} , and I_{rms} to be exported to the PC for the control algorithm. It also provides error detection/correction and digital filtering. The system controller is fully programmable so that new global and/or local controls can be implemented rapidly. This experimental setup is described in more detail in [12].

The four-quadrant operating regions of each of the STATCOM/BESS are shown in Fig. 6. This figure maps out the quasi steady-state region for each topology by varying the STATCOM output angle and magnitude while maintaining the battery string current under 17 A. Other comparison metrics are given in Table II.

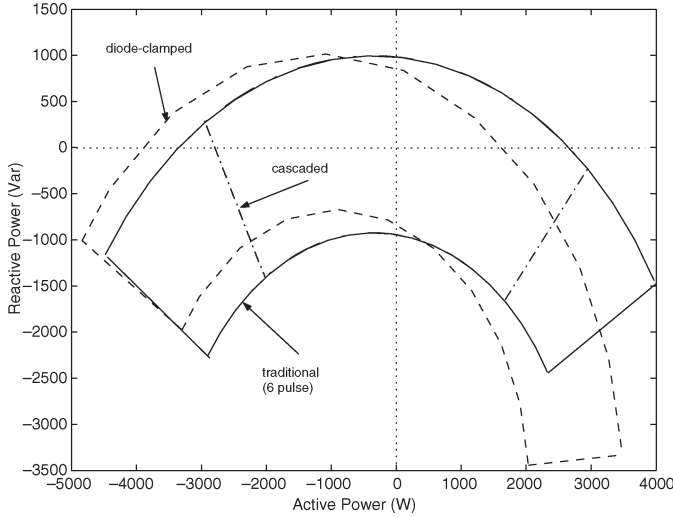

Fig. 6. Comparison of operating regions.

TABLE II
TOPOLOGY COMPARISON METRICS

Metric	Traditional	Cascaded	Diode-Clamped
Output ac Voltage (V)	265	177	265
Rating (VA)	4600	3000	5000
no. of batteries	36	36	36
V_{DC} (V)	432	72	108
Switching losses	$6K$	K	$\frac{3}{2}K$
no. of IGBTs (w/flyback diode)	6	24	24
no. of clamping diodes	0	0	36
THD (%)	66	14	14

The operating regions shown in Fig. 6 are wedges of a complete circle, which is obtained by varying the firing angle from 0° to 360° and the modulation gain from $k = 0$ to $k = 1$. The wedges are obtained by truncating the regions when the battery current exceeds the 17-A limit. The centers of the circular operating regions are offset from the origin due to the reactive and inductive losses of the transformer and transmission line since the output is measured at the end of the transmission line that couples the STATCOM/BESS to the system. If the regions were measured at the secondary coupling transformer, the center of the regions would be located near the origin.

As shown in Fig. 6, the cascaded and traditional six-pulse STATCOM/BESSs have very similar regions, except the cascaded-converter active power and reactive power (PQ) operating range is significantly smaller. This is due to that fact that the cascaded topology has a lower ac system output voltage; therefore, a larger current is required to achieve the same output power. The current limits of the batteries therefore effectively shrink the operating region of the cascaded converter.

The diode-clamped-converter region is similar to that of the traditional six-pulse converter, except that it is shifted slightly to the left to account for greater switching losses. This becomes increasingly apparent as the BESS discharges (high values of active-power output).

Table II also highlights several differences between the topologies. As noted previously, for the same number of batteries, the cascaded-converter ac system output voltage is lower than that of the other topologies. Thus, a transformer will be required to boost the output voltage to the same ac system level. As shown in Table II, the output-power ratings of the traditional and diode-clamped converters are similar, but the cascaded converter is rated at about 60% as a result of the lower output-voltage level. However, the cascaded converter also has the lowest switching losses of the three converters. Lastly, the cascaded and diode-clamped converters have similar total harmonic distortion levels.

V. PERFORMANCE COMPARISONS

The previous section highlighted the steady-state properties of each of the topologies; in this section, the experimental dynamic performance of the converters is compared. To evenly compare the performances, an active and reactive power control is developed based upon the fundamental frequency model of the STATCOM/BESS.

In the $d-q$ system reference, the fundamental frequency STATCOM/BESS can be modeled as [7]

$$\frac{1}{\omega_s} \frac{d}{dt} \begin{bmatrix} i_d \\ i_q \\ V_{dc} \end{bmatrix} = \begin{bmatrix} -\frac{R'_s}{L'_s} & \frac{\omega_s}{L'_s} & 0 \\ \frac{\omega_s}{L'_s} & -\frac{R'_s}{L'_s} & 0 \\ 0 & 0 & -\frac{R'_b R'_{dc}}{C'(R'_{dc} + R'_b)} \end{bmatrix} \begin{bmatrix} i_d \\ i_q \\ V_{dc} \end{bmatrix} + k \begin{bmatrix} \frac{V_{dc}}{L'_s} \cos(\alpha + \theta) \\ \frac{V_{dc}}{L'_s} \sin(\alpha + \theta) \\ -\frac{i_d}{C'} \cos(\alpha + \theta) - \frac{i_q}{C'} \sin(\alpha + \theta) \end{bmatrix} - \begin{bmatrix} \frac{V_s \cos \theta}{L'_s} \\ \frac{V_s \sin \theta}{L'_s} \\ \frac{-V_b}{R'_b C'} \end{bmatrix} \quad (1)$$

where i_d and i_q are the injected per-unit $d-q$ STATCOM currents, V_{dc} is the per-unit voltage across the dc capacitor C' , R'_s and L'_s represent the STATCOM transformer active and reactive power losses, k is the PWM modulation gain, α is the angle between the ac system and the STATCOM voltages, ω is the frequency of the STATCOM voltage, ω_s is the synchronous frequency, V_b is the per-unit battery voltage, R'_b represents the battery losses, R'_{dc} represents the switching losses, and $V_s \angle \theta$ is the per-unit ac system side bus voltage.

The controller provides active and reactive power commands to achieve the desired system response. The controller converts the commanded powers into PWM switching commands for the STATCOM/BESS to regulate the modulation gain and angle. For the best control of transmission capacity, it is desired to have a controller that can achieve independent active and reactive power responses. To accomplish this goal, a decoupled proportional-integral (PI) controller that can produce the desired switching commands from independent active and reactive power commands is developed.

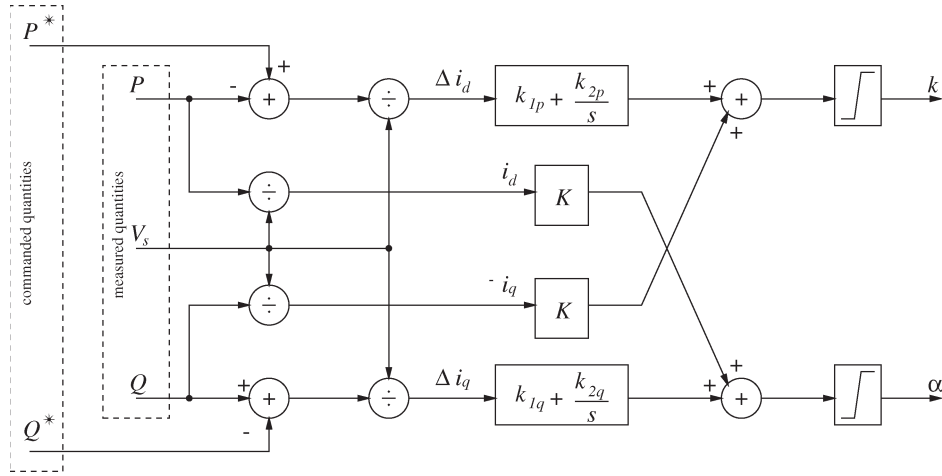

Fig. 7. Decoupled PQ control.

Since the control is locally defined for each particular STATCOM/BESS, the system bus voltage angle θ may be taken to be identically zero in the control without loss of generality. Therefore, the STATCOM/BESS active power P and reactive power Q on the ac power system side can be calculated in d - q reference frame coordinates as

$$P = V_s i_d, \quad Q = -V_s i_q \quad (2)$$

where realizing the decoupled active and reactive power control can be achieved through decoupled i_d and i_q control.

At the equilibrium, there is no active-power exchange between the STATCOM and battery; thus, the first two rows of (1) may be linearized to obtain

$$\frac{d}{dt} \begin{bmatrix} \Delta i_d \\ \Delta i_q \end{bmatrix} = \omega_s \begin{bmatrix} -\frac{R'_s}{L'_s} & 0 \\ 0 & -\frac{R'_s}{L'_s} \end{bmatrix} \begin{bmatrix} \Delta i_d \\ \Delta i_q \end{bmatrix} + \begin{bmatrix} x_1 \\ x_2 \end{bmatrix} \quad (3)$$

$$\begin{bmatrix} x_1 \\ x_2 \end{bmatrix} = \begin{bmatrix} \omega_0 \Delta i_q + \frac{k_0}{L'_s} \Delta V_{dc} + \frac{V_{dc0}}{L'_s} \Delta k_0 \\ \frac{V_{dc0} k_0}{L'_s} \Delta \alpha - \omega_0 \Delta i_d \end{bmatrix} \quad (4)$$

where $[x_1 x_2]^T$ is the control variable vector. In the STATCOM/BESS system, the dc voltage is held nearly constant by the battery; therefore, the incremental change ΔV_{dc} is negligible. By combining (2)–(4), a local PI controller for producing a PWM modulation index k and angle α from a commanded P^* and Q^* can be developed, as shown in Fig. 7. If $K = 0$, this controller is decoupled; k is used to control P , and α is used to control Q . This control is used in the following comparison of the experimental performances of the different converters.

Figs. 8 and 9 show a comparison of the experimental results of the cascaded and diode-clamped (with 4BESS) converter outputs to a commanded step change in the active and reactive power outputs. In these experiments, the STATCOM/BESS are connected through a transmission line to an infinite bus. The commanded changes are operating from idle to the first quadrant ($P > 0, Q > 0$) and from idle to the third quadrant ($P < 0, Q < 0$). Both topologies utilize the same number of battery modules. The converters exhibit comparable dynamic responses.

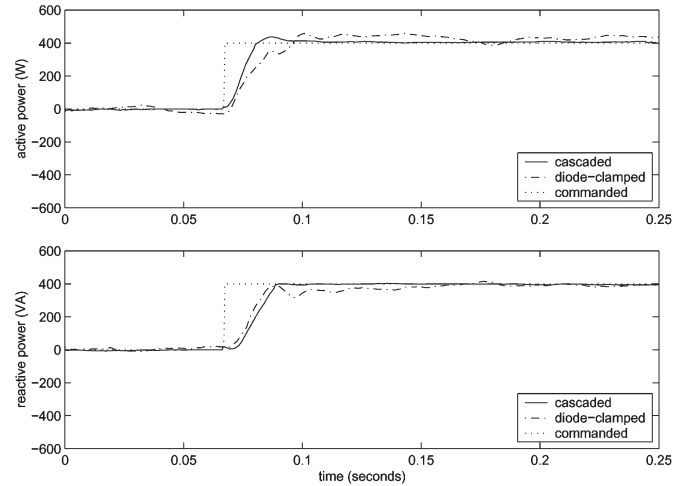

Fig. 8. Experimental results comparison for a commanded step change increase.

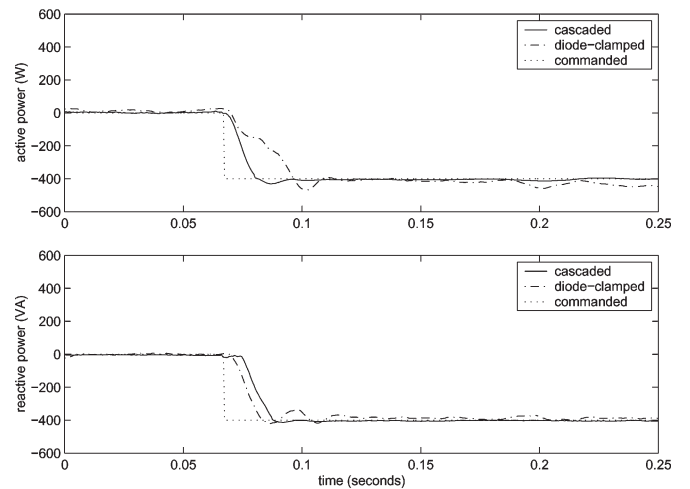

Fig. 9. Experimental results comparison for a commanded step change decrease.

The independent control of both active and reactive powers in STATCOM/BESSs make them ideal controllers for many types of power system applications, including voltage control and oscillation damping. One particularly attractive use of the

STATCOM/BESS is to stabilize disturbances to the power system. Consider the following scenario where a short circuit is applied to the power system and then cleared after three cycles. The fault induces an undesirable oscillation in the power system power flow and voltage. The active and reactive power injections of the STATCOM/BESS to stabilize the power system short circuit are shown in Fig. 10(a). The STATCOM/BESS will inject or absorb active and reactive powers in antipathy with the line flows to damp the oscillations. The active and reactive power injection is mapped onto the operating range of the three topologies in Fig. 10(b). Note that the active power undergoes a much larger transversal than the reactive power to damp the oscillation. The reactive power settles to a new higher value to compensate for the change in voltage levels, but the active power starts and ends at roughly 0 W since the battery is initially at idle and cannot discharge or charge indefinitely.

VI. EFFECT OF BESS SIZE ON STABILITY

A hardware setup based on a five-level diode-clamped converter has been constructed at the University of Missouri-Rolla. The experimental STATCOM was interfaced with a battery set that consists of 36 valve regulated lead acid super-gel batteries in four strings of nine batteries, with each string at 108 Vdc. Each battery has a current limit of 17 A. The laboratory parameters were applied to build the simulation models of the STATCOM and STATCOM/BESS in the software package PSCAD. The diode-clamped topology allows easy reconfiguration of the BESS to synthesize different-capacity ESSs. The STATCOM and STATCOM/BESS have the same reactive-power ranges. In the remainder of this section, STATCOM/2BESS will indicate a diode-clamped STATCOM with only two battery strings (out of possibly four strings), whereas STATCOM/4BESS will indicate a diode-clamped STATCOM with four battery strings.

The dynamic performances of the STATCOM, STATCOM/2BESS, and STATCOM/4BESS are compared in a scenario where a three-phase fault occurs at the midpoint of a single-generator-infinite-bus system and is cleared after a short period. Three cases were simulated with different fault times: 50, 95, and 110 ms. Figs. 11–13 show the rotor speed, midpoint voltage, and injected active power corresponding to the three faults, respectively.

In the case of the 50-ms fault, all of the systems remain stable. In the case of the 95-ms fault, the original system and the system with the STATCOM only go unstable, while the two STATCOM/BESS systems remain stable. In the case of the 110-ms fault, all of the systems go unstable, except the STATCOM/4BESS system. Therefore, the controllers studied can be ranked in terms of increasing impact on oscillation damping and transient stability as STATCOM, STATCOM/2BESS, and STATCOM/4BESS. The ability of the STATCOM/BESS to inject active power considerably improves the stability of the system, almost doubling the critical clearing time of the STATCOM system. The difference between the STATCOM/2BESS and STATCOM/4BESS is not as dramatic, but the additional active-power capabilities add additional damping control.

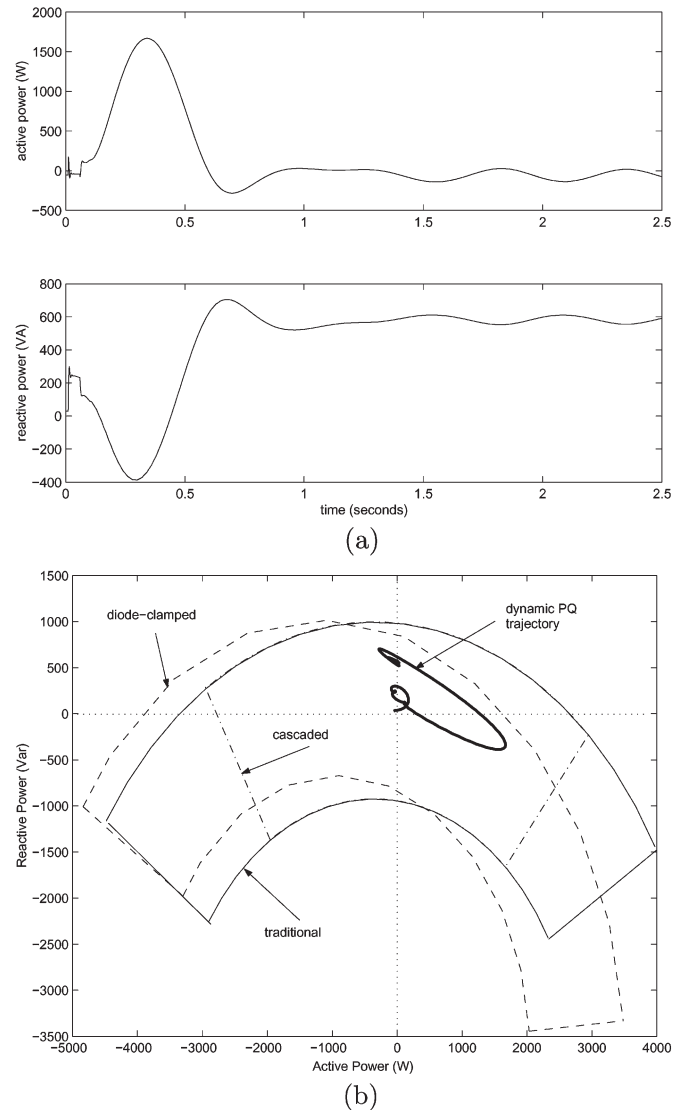
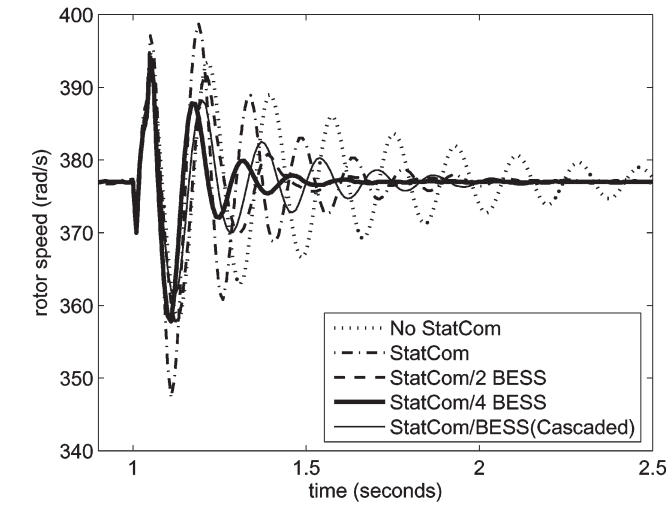
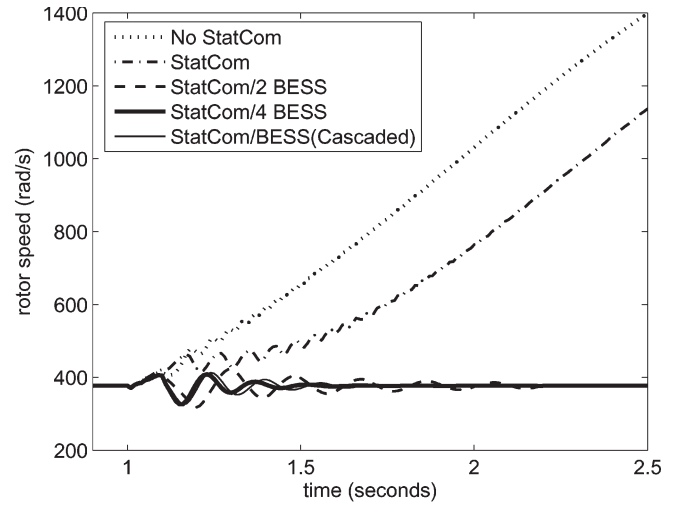

Fig. 10. (a) Time-domain simulation. (b) Operating range STATCOM active and reactive power injection.

The surprising result of these comparisons is that the STATCOM/2BESS actually injects greater active power than the STATCOM/4BESS. The reasons for this are not obvious. The STATCOM/BESS is designed to inject or absorb active power in antipathy with the oscillations on the controlled line. Note that during the first swing of the oscillation, the STATCOM absorbs considerable active power. This injected power is going into switching and heating losses to maintain the dc-link-capacitor voltage. Since the STATCOM/BESS has the same transformer and power electronics as the STATCOM, it will also attempt to draw the same active power, but rather than coming from the system, a part of the active-power requirement comes from the batteries. As the oscillation continues, both STATCOM/BESSs start to inject active power, but because the STATCOM/2BESS initially drew more active power, it must now inject more active power to respond to the same control command. In addition, because of the balancing circuit, the STATCOM/2BESS responds slightly slower than the STATCOM/4BESS.



(a)



(a)

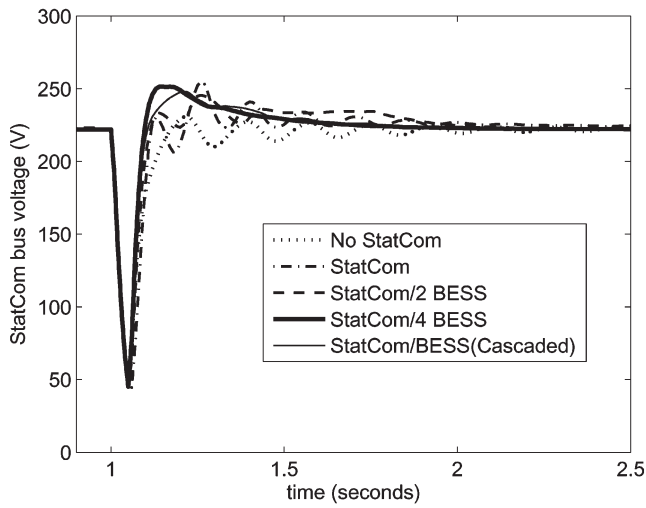

(b)

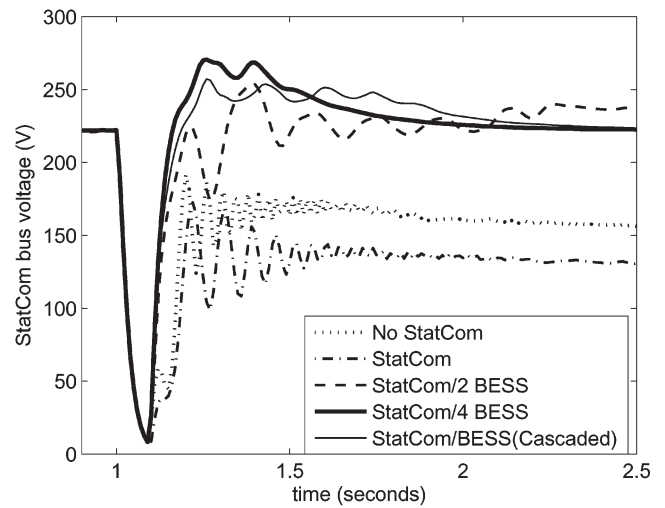

(b)

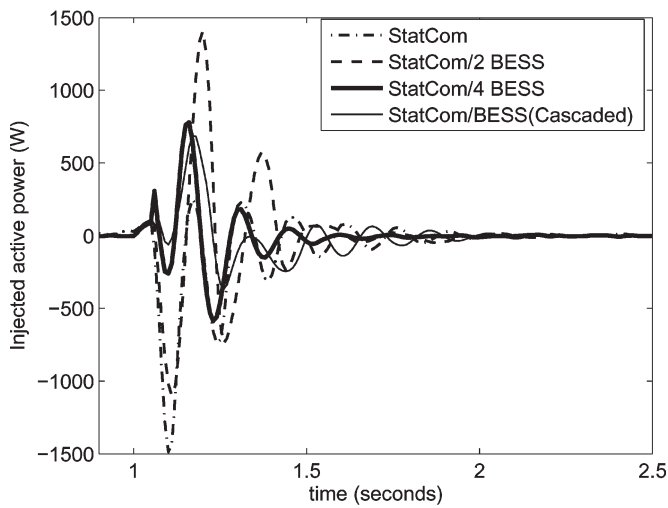

(c)

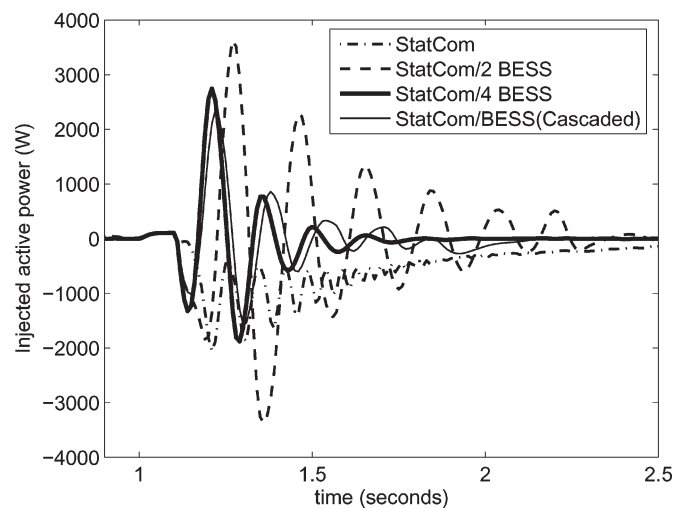

(c)

Fig. 11. Response to a 50-ms fault. (a) Rotor speed. (b) STATCOM bus voltage. (c) Injected active power.

Fig. 12. Response to a 95-ms fault. (a) Rotor speed. (b) STATCOM bus voltage. (c) Injected active power.

Additionally, note that the cascaded STATCOM/BESS has similar ability to damp oscillations compared with the STATCOM/4BESS but injects less active and reactive power

as expected. The lower injected active power leads to less damping capability compared with the STATCOM/4BESS, as seen from the greater oscillatory response. The lower

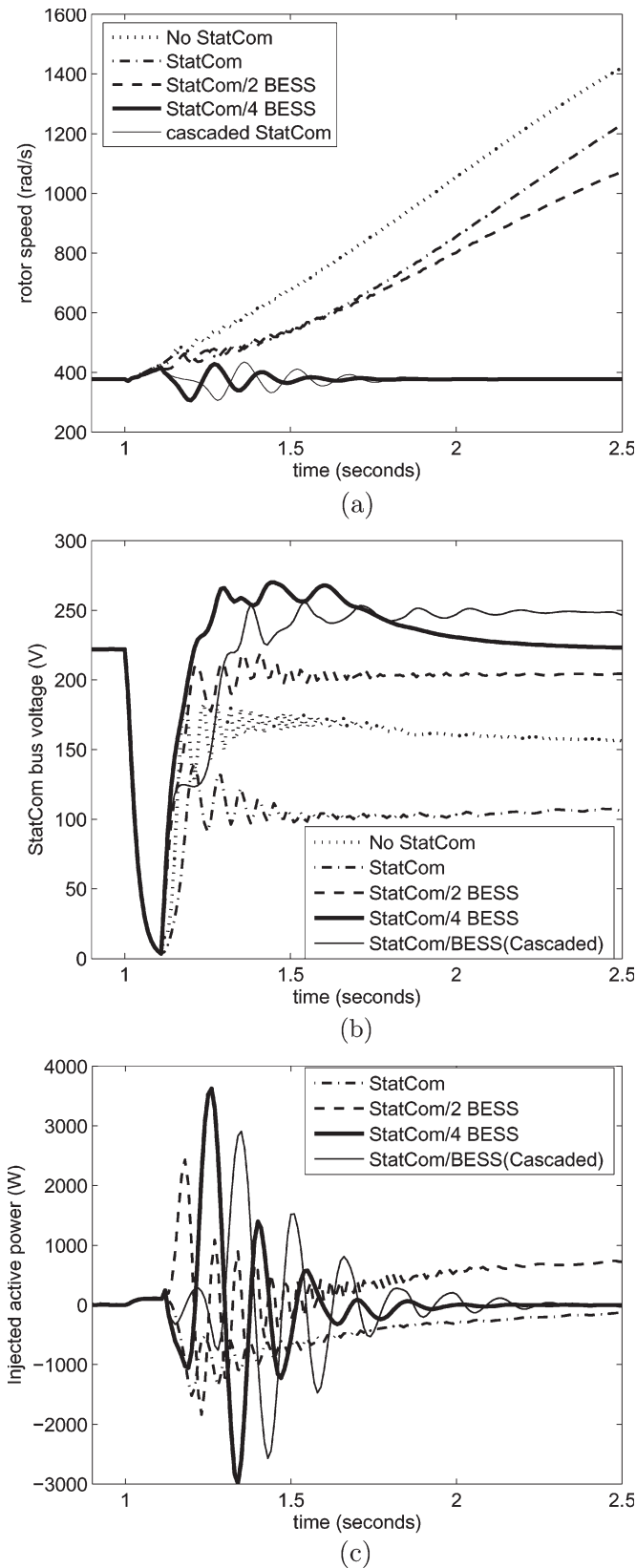

Fig. 13. Response to a 110-ms fault. (a) Rotor speed. (b) STATCOM bus voltage. (c) Injected active power.

injected reactive power affects the cascaded STATCOM/BESS's ability to effectively control the voltage, as shown in Fig. 13(b). The voltage magnitude for the cascaded

STATCOM/BESS takes considerably longer to return to the reference value.

VII. CONCLUSION

This paper compared and contrasted traditional and multi-level power converters for a hybrid STATCOM/BESS. Each of the multilevel topologies exhibits several advantages and disadvantages. The cascaded converter provides lower switching losses, modularity, and simpler charge-balancing approaches. The greatest disadvantage of the cascaded converter is the lower output-voltage rating and the corresponding output-power rating. The diode-clamped converter provides a larger operating range and the ability to use fewer batteries with a balancing circuit. The primary disadvantage of the diode-clamped converter is the complexity of the control that is required to balance the voltages and the number of clamping diodes required. Both converters exhibited comparable dynamic performance in response to commanded changes in active and reactive power.

REFERENCES

- [1] IEEE power engineering society FACTS application task force, *FACTS applications*, IEEE Pub 96-TP116-0, 1996.
- [2] P. Ribeiro, B. Johnson, M. L. Crow, A. Arsoy, and Y. Liu, "Energy storage systems for advanced power applications," *Proc. IEEE*, vol. 89, no. 12, pp. 1744–1756, Dec. 2001.
- [3] A. Arsoy, Y. Liu, P. Ribeiro, and F. Wang, "STATCOM-SMES," *IEEE Ind. Appl. Mag.*, vol. 9, no. 2, pp. 21–28, Mar./Apr. 2003.
- [4] S. Eckrood, "FACTS with energy storage: Conceptual design study," EPRI, Palo Alto, CA, EPRI Report TR-111093, 1999.
- [5] S. Arabi and P. Kundur, "Stability modeling of storage devices in FACTS applications," in *Proc. IEEE Power Eng. Soc. Summer Meeting*, Jul. 2001, vol. 2, pp. 767–771.
- [6] A. Arulampalam, J. B. Ekanayake, and N. Jenkins, "Application study of a STATCOM with energy storage," *Proc. Inst. Electr. Eng.—Gener. Transm. Distrib.*, vol. 150, no. 3, pp. 373–384, May 2003.
- [7] Z. Yang, C. Shen, L. Zhang, M. L. Crow, and S. Atcitty, "Integration of a STATCOM and battery energy storage," *IEEE Trans. Power Syst.*, vol. 16, no. 2, pp. 254–260, May 2001.
- [8] L. Zhang, C. Shen, M. L. Crow, L. Dong, S. Pekarek, and S. Atcitty, "Performance indices for the dynamic performance of FACTS and FACTS with energy storage," *Electr. Power Syst. Compon. Syst.*, vol. 33, no. 3, pp. 299–314, Mar. 2005.
- [9] D. Soto and T. Green, "A comparison of high-power converter topologies for the implementation of FACTS controllers," *IEEE Trans. Ind. Electron.*, vol. 49, no. 5, pp. 1072–1080, Oct. 2002.
- [10] J. S. K. Leung, S. Y. Hui, H. S.-H. Chung, and C. K. Lee, "Circuit-level comparison of STATCOM technologies," *IEEE Trans. Power Electron.*, vol. 18, no. 4, pp. 1084–1092, Jul. 2003.
- [11] L. Tolbert and F. Peng, "Multilevel converters as a utility interface for renewable energy systems," in *Proc. IEEE Power Eng. Soc. Summer Meeting*, Jul. 2000, vol. 2, pp. 1271–1274.
- [12] L. Dong, M. Crow, Z. Yang, S. Chen, L. Zhang, and S. Atcitty, "A reconfigurable FACTS system for university laboratories," *IEEE Trans. Power Syst.*, vol. 19, no. 1, pp. 120–128, Feb. 2004.
- [13] Y. Liu, Z. Zhao, C. Qian, and X. Zhou, "A novel three-phase multilevel voltage source converter," in *Proc. PIEMC*, vol. 3, pp. 1172–1175.
- [14] F. Peng, "A generalized multilevel inverter topology with self voltage balancing," in *Proc. IEEE-IAS Annu. Meeting*, Oct. 2000, vol. 3, pp. 2024–2031.
- [15] B.-R. Lin, "Analysis and implementation of a three-level PWM rectifier/inverter," *IEEE Trans. Aerosp. Electron. Syst.*, vol. 36, no. 3, pp. 948–956, Jul. 2000.
- [16] M. Botao, L. Congwei, Z. Wang, and L. Fahai, "New SVPWM control scheme for three-phase diode clamping multilevel inverter with balanced dc voltages," in *Proc. Annu. Conf. IEEE Ind. Electron. Soc.*, Nov. 2002, vol. 2, pp. 903–907.
- [17] M. Marchesoni and P. Tenca, "Diode-clamped multilevel converters: A practical way to balance dc-link voltages," *IEEE Trans. Ind. Electron.*, vol. 49, no. 4, pp. 752–765, Aug. 2002.



Ying Cheng (M'05) received the B.S. and M.S. degrees from Shanghai Jiao Tong University, Shanghai, China, in 1997 and 2000, respectively, and the Ph.D. degree in electrical engineering from the University of Missouri, Rolla, in 2004.

She is currently a Postdoctoral Fellow with the Department of Electrical and Computer Engineering, University of Missouri, Rolla. Her research interests include flexible-ac-transmission-system control, power electronics, and applications in power systems.

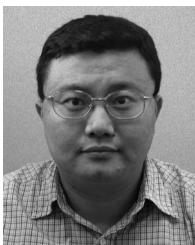

Chang Qian (M'04) received the B.S. and M.S. degrees from Tsinghua University, Beijing, China, and the Ph.D. degree in electrical engineering in 2004 from the University of Missouri, Rolla.

He is currently with International Rectifier, El Segundo, CA. His research interests include power electronics, flexible ac transmission systems, and power system.



Mariesa L. Crow (SM'94) received the B.S.E. degree from the University of Michigan, Ann Arbor, and the Ph.D. degree in 1989 from the University of Illinois, Urbana-Champaign.

She is currently with the University of Missouri, Rolla, where she is the Dean of the School of Materials, Energy, and Earth Resources and a Professor of electrical and computer engineering. Her research interests include developing computational methods for dynamic security assessment and applying power electronics in bulk power systems.



Steve Pekarek (M'96) received the Ph.D. degree in electrical engineering from Purdue University, West Lafayette, IN, in 1996.

From 1997 to 2004, he was a member of the faculty of the Department of Electrical and Computer Engineering, University of Missouri, Rolla. He is currently an Associate Professor of electrical and computer engineering with Purdue University, where he is also the Codirector of the Energy Systems Analysis Consortium. His research interests include the analysis and design of power-electronics-based

architectures for finite-inertia power and propulsion systems.



Stan Atcitty (S'91–A'06) received the B.S. and M.S. degrees in electrical engineering from New Mexico State University, Las Cruces, in 1993 and 1995, respectively.

He is currently with Sandia National Laboratories, Albuquerque, NM, where he is a Senior Member of Technical Staff with the Power Sources Development Department and a Power Electronics Consultant under the Energy Storage Program. His research interests include high-power electronics and applications in power systems.